

Ο ΙΩΝΙΚΟΣ ΡΥΘΜΟΣ

- ΜΕΡΗ, ΟΝΟΜΑΤΟΛΟΓΙΑ

VITRUVIUS

- ΑΡΣΕΝΙΚΟ
- ΘΗΛΥΚΟ

ΧΑΡΑΚΤΗΡΙΣΤΙΚΑ ΔΩΡΙΚΟΥ ΡΥΘΜΟΥ

- ΤΡΙΒΑΘΜΗ ΚΡΗΠΙΔΑ
- ΠΕΡΙΠΤΕΡΟΣ ΤΥΠΟΣ
- ΕΝΤΑΣΗ ΣΤΟΥΣ ΚΙΟΝΕΣ
- ΑΕΤΩΜΑ
- ΑΕΤΩΜΑΤΙΚΑ ΓΛΥΠΤΑ
- ΕΣΩΤΕΡΙΚΟΙ ΚΙΟΝΕΣ* ΕΝΔΙΑΦΕΡΟΝ ΓΙΑ ΤΟ ΕΣΩΤΕΡΙΚΟ
- ΟΠΤΙΚΕΣ ΔΙΟΡΘΩΣΕΙΣ



Ο ΠΑΡΘΕΝΩΝΑΣ ΤΟΥ ΝΑΣΗΒΙΛΛΕ, ΤΕΧΑΣ



Ο πυκνός Ελληνικός ναός ... περισσότερο κλειστός



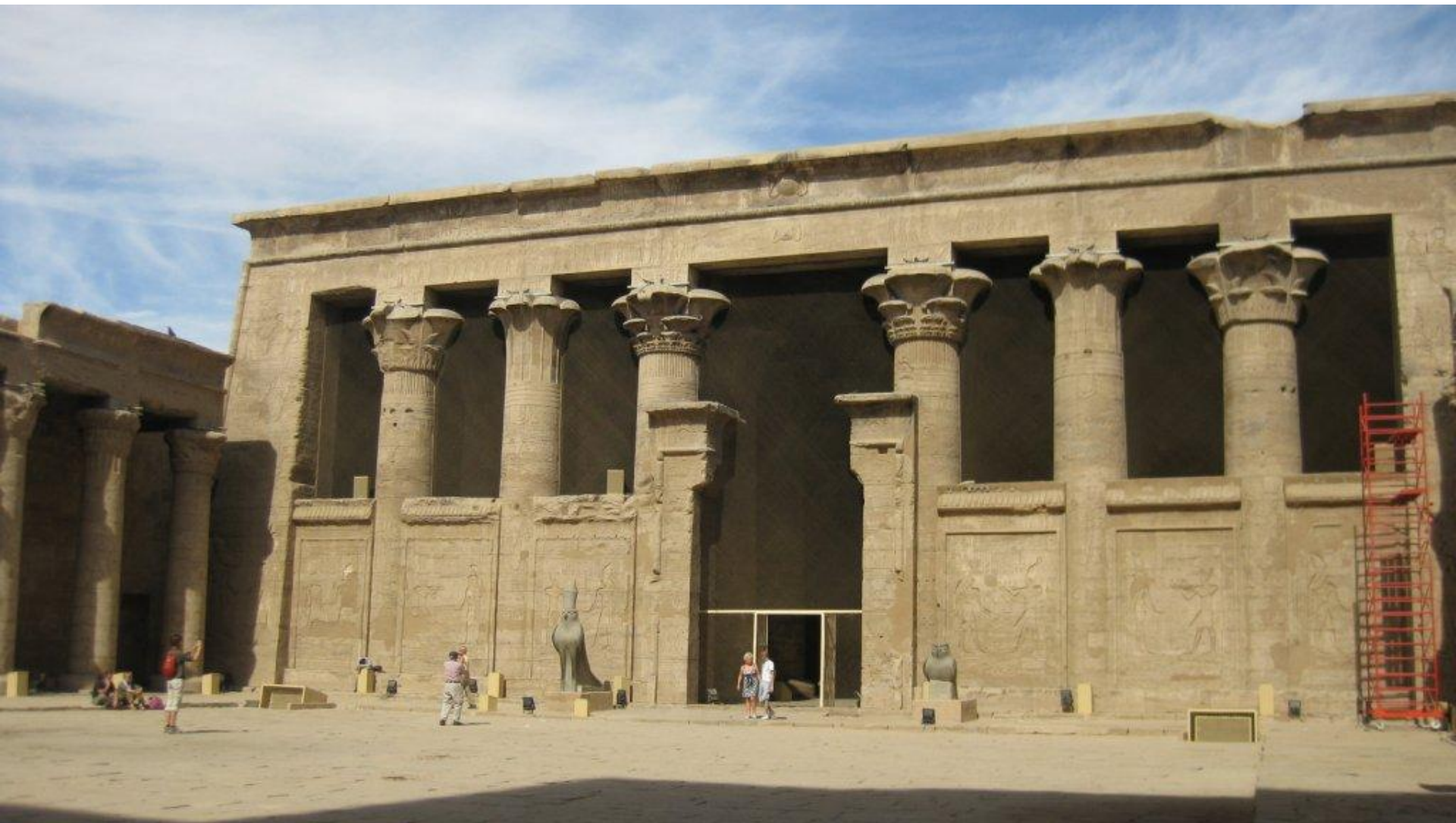

- Ομοιομορφία

Ο χορηγός και η ανομοιομορφία



κολοσσικό

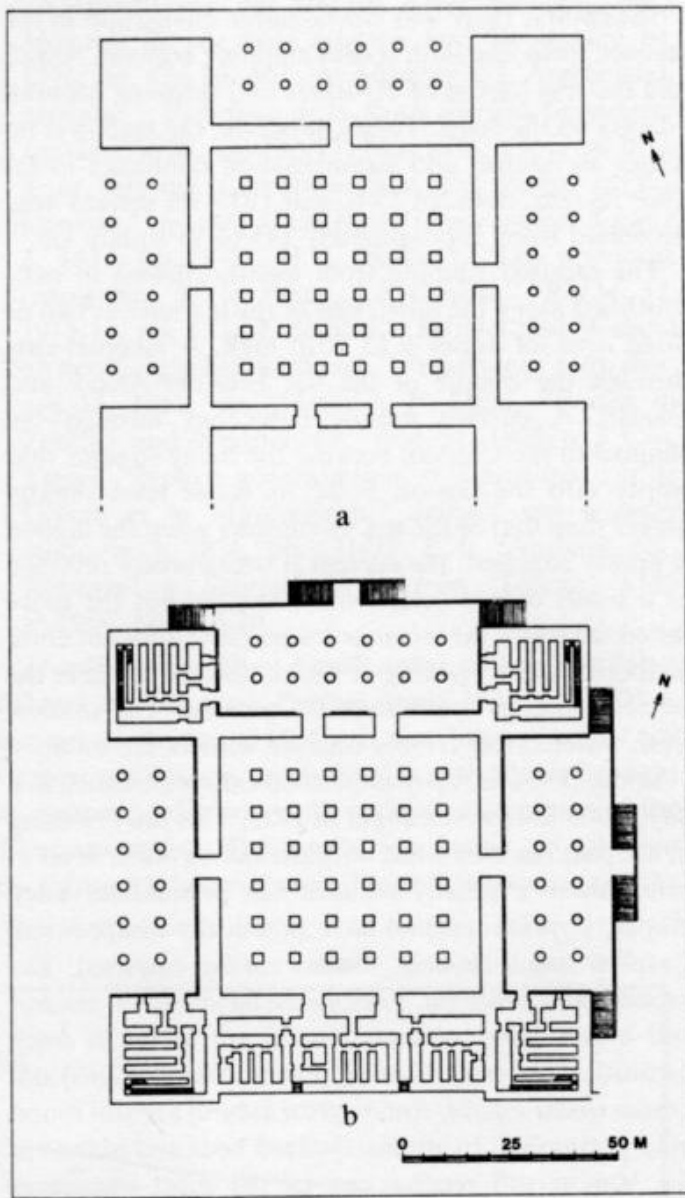
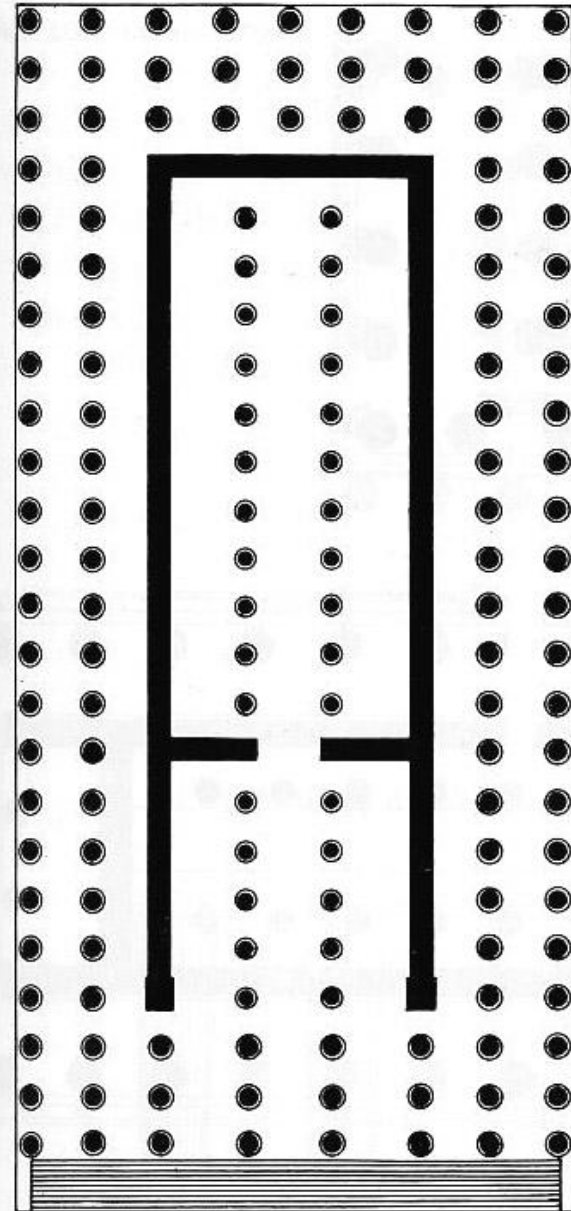
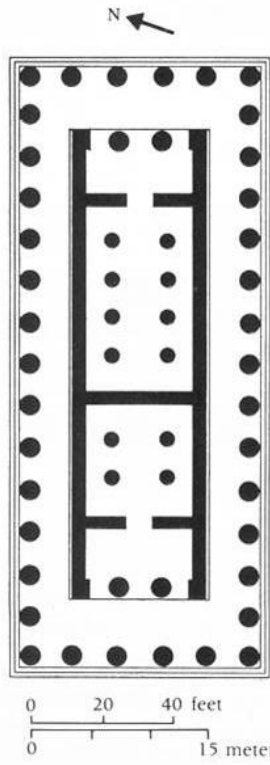
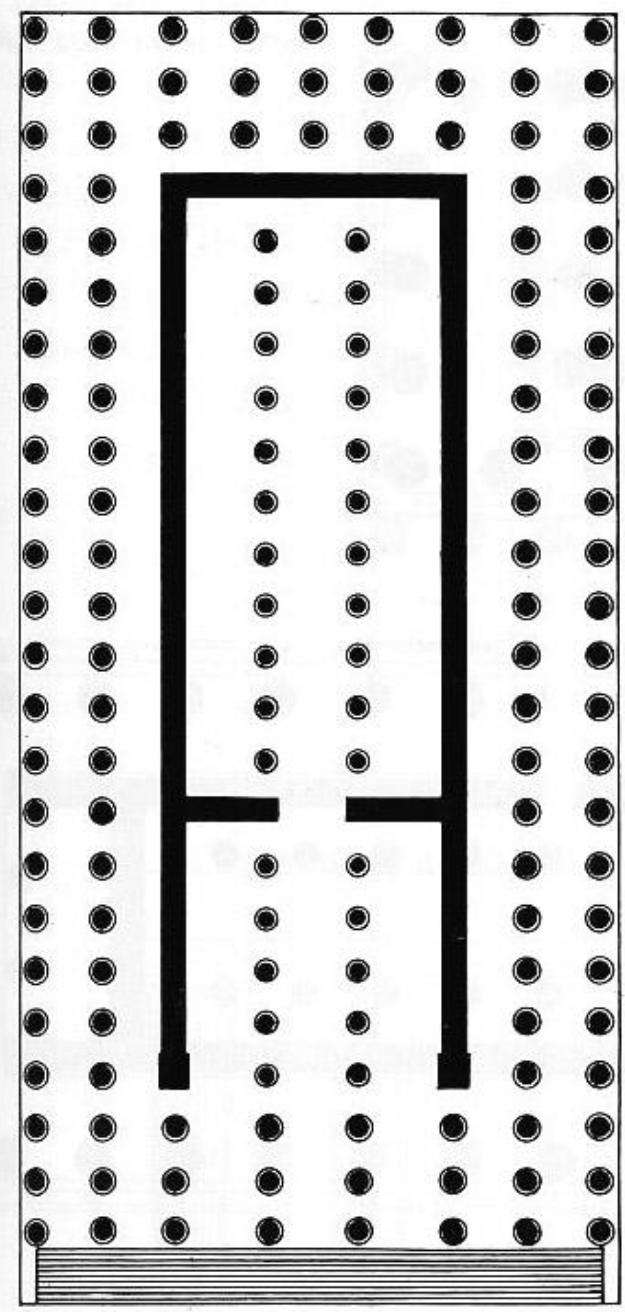

Figure 4. Partly restored ground plans of the Apadāna at Susa (a) and of the Apadāna at Persepolis (b). After Perrot and Schmidt.





ΔΩΡΙΚΟΣ
ΠΕΡΙΠΤΕΡΟΣ



ΙΩΝΙΚΟΣ
ΚΟΛΟΣΣΙΚΟΣ
ΔΙΠΤΕΡΟΣ

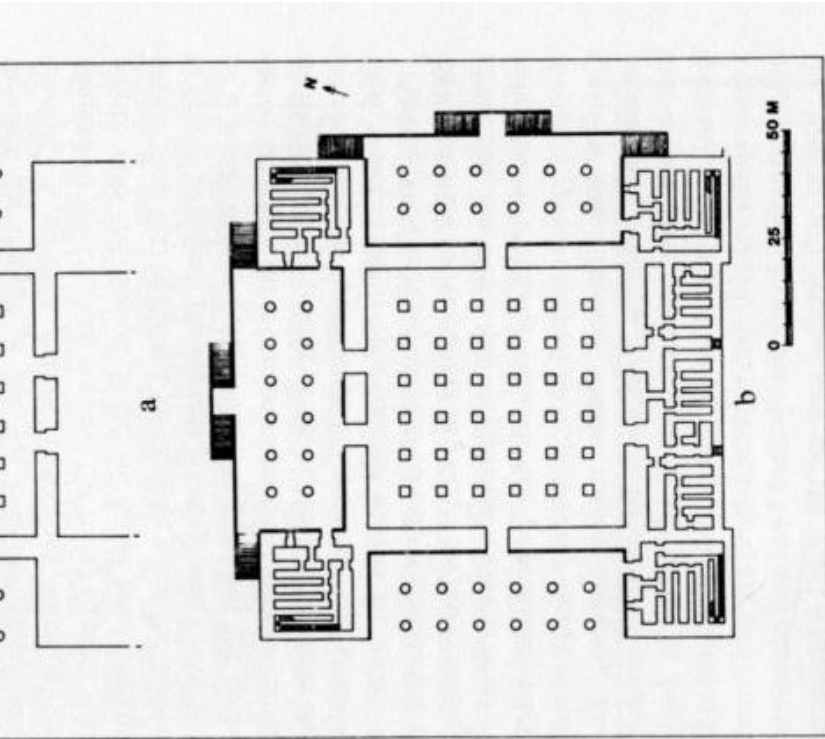
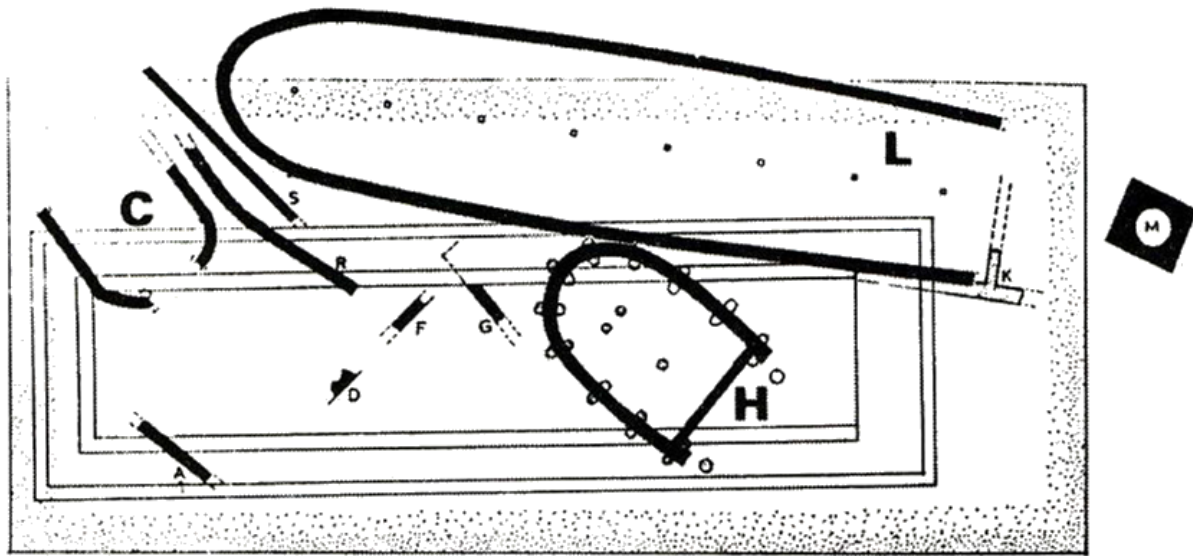

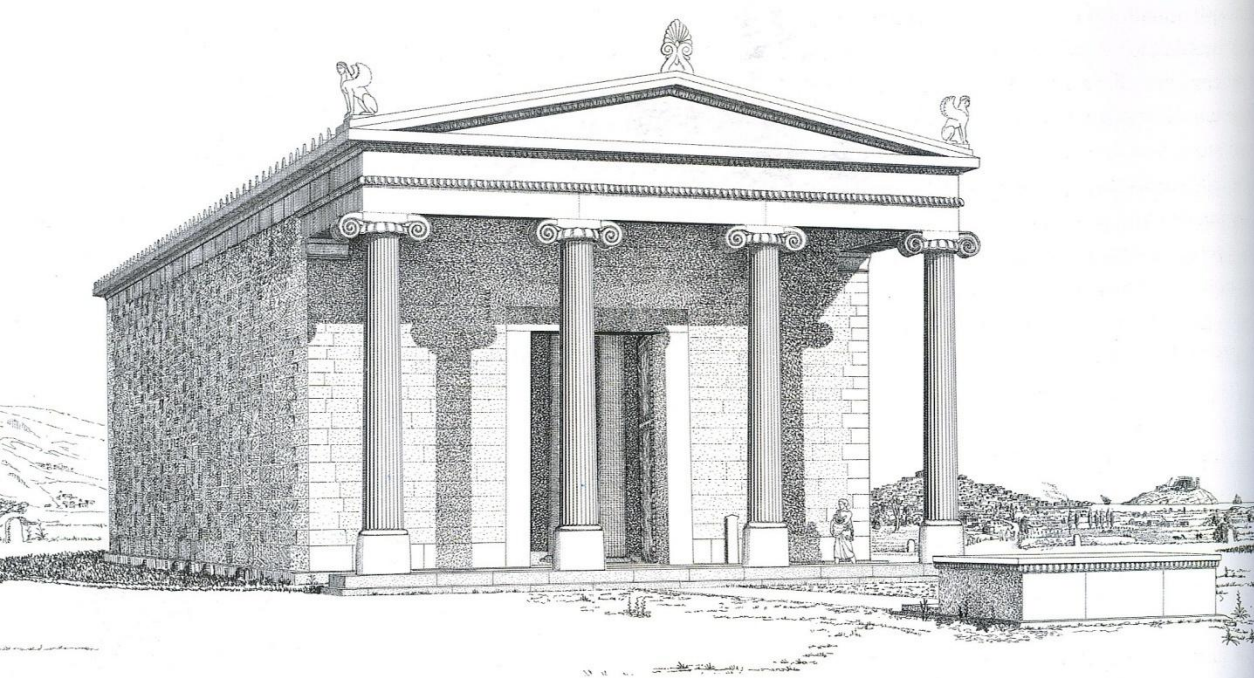

ΠΡΟΣΤΥΛΟΣ ΙΩΝΙΚΟΣ ΤΥΠΟΣ

ΥΡΙΑ, ΝΑΕΟΣ
(580- 550)



Φωτογραφία του χώρου

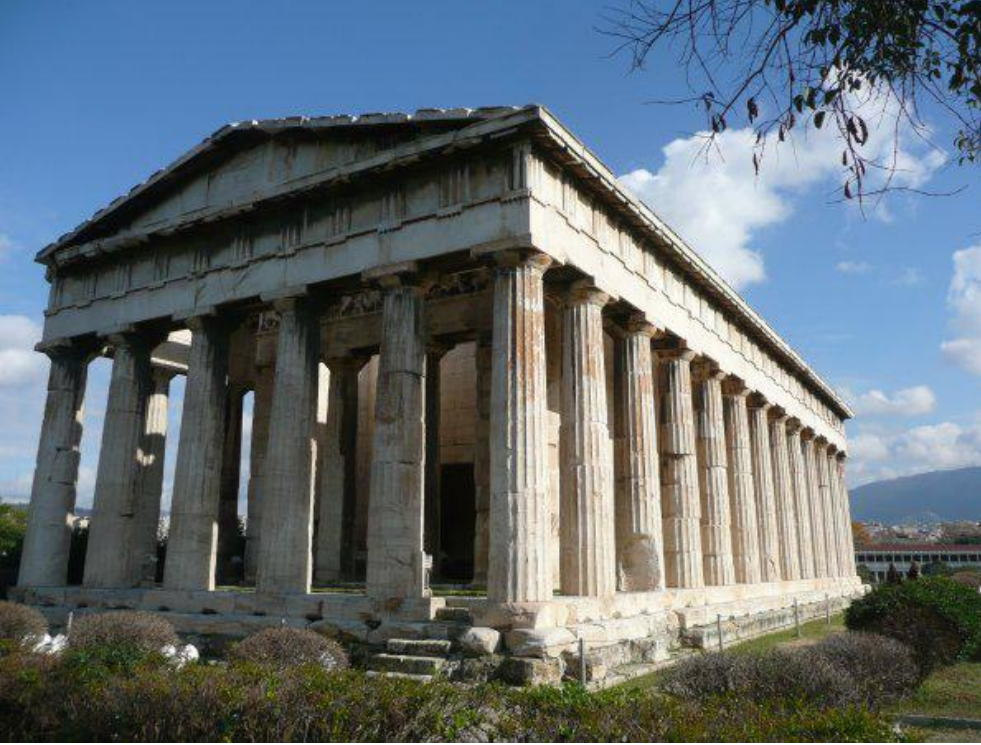

ΔΩΡΙΚΕΣ
ΤΡΙΒΑΘΜΕΣ ΚΡΗΠΙΔΕΣ



ΙΩΝΙΚΕΣ
ΠΟΛΥΒΑΘΜΕΣ ΚΡΗΠΙΔΕΣ

ΝΕΟΤΕΡΟ ΑΡΤΕΜΙΣΙΟ ΕΦΕΣΟΥ

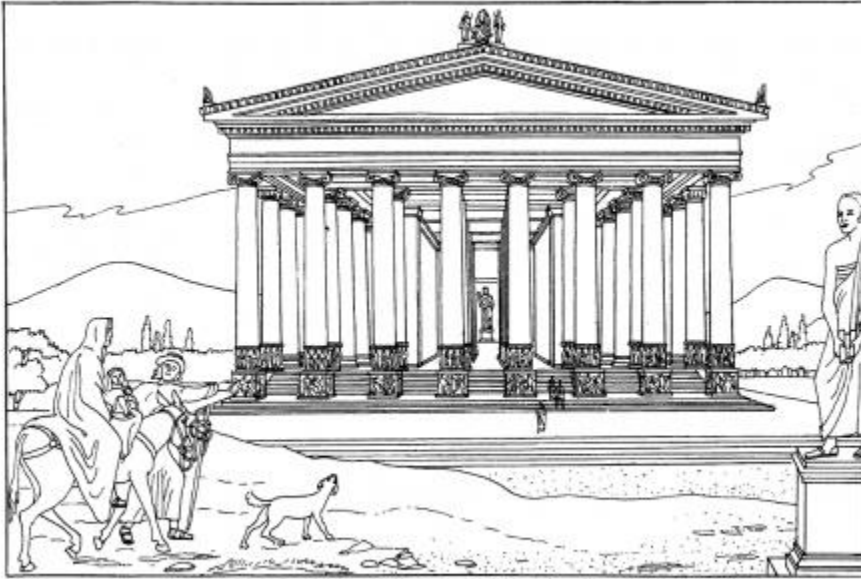

ΝΕΟΤΕΡΟ ΑΡΤΕΜΙΣΙΟ ΕΦΕΣΟΥ

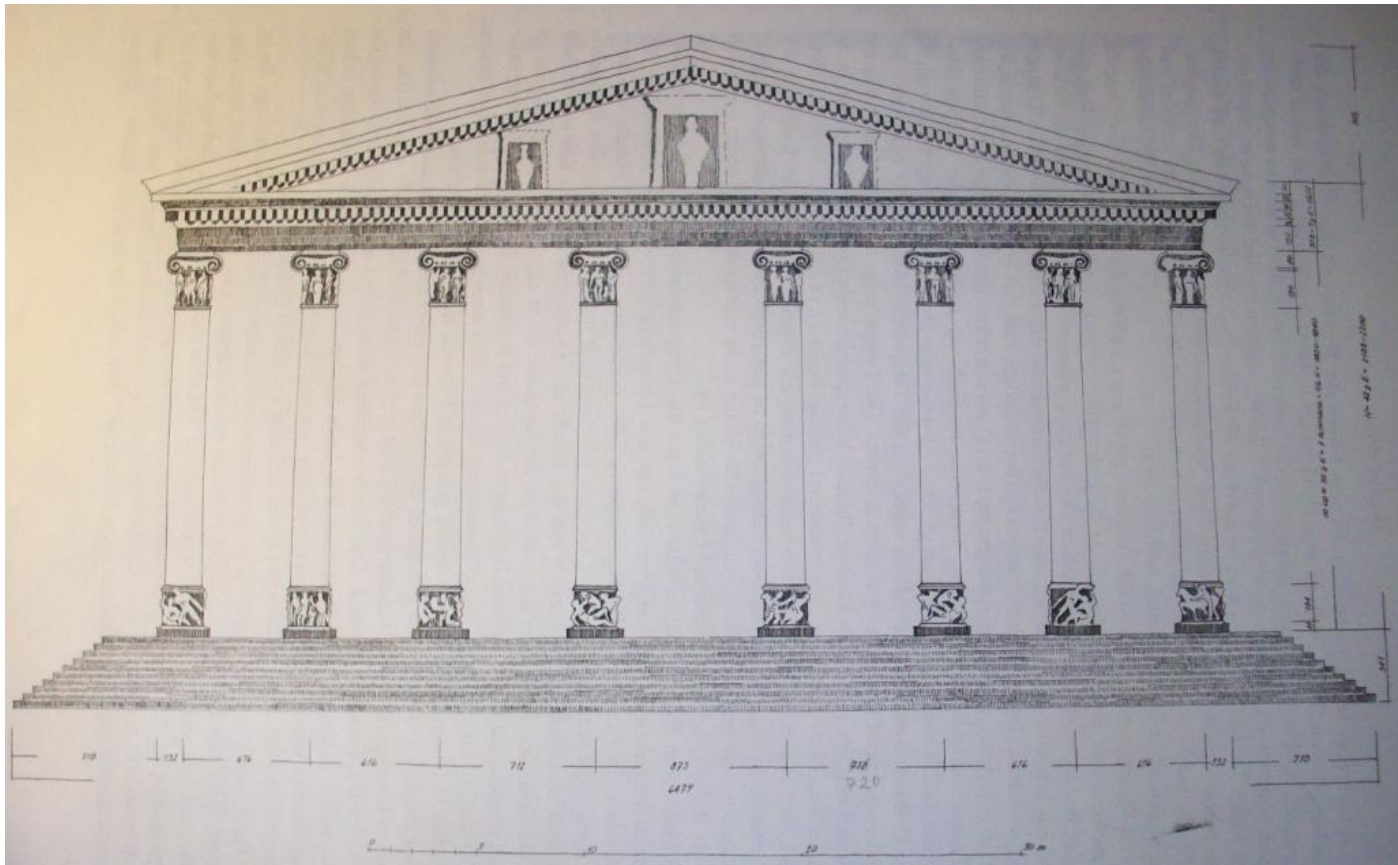

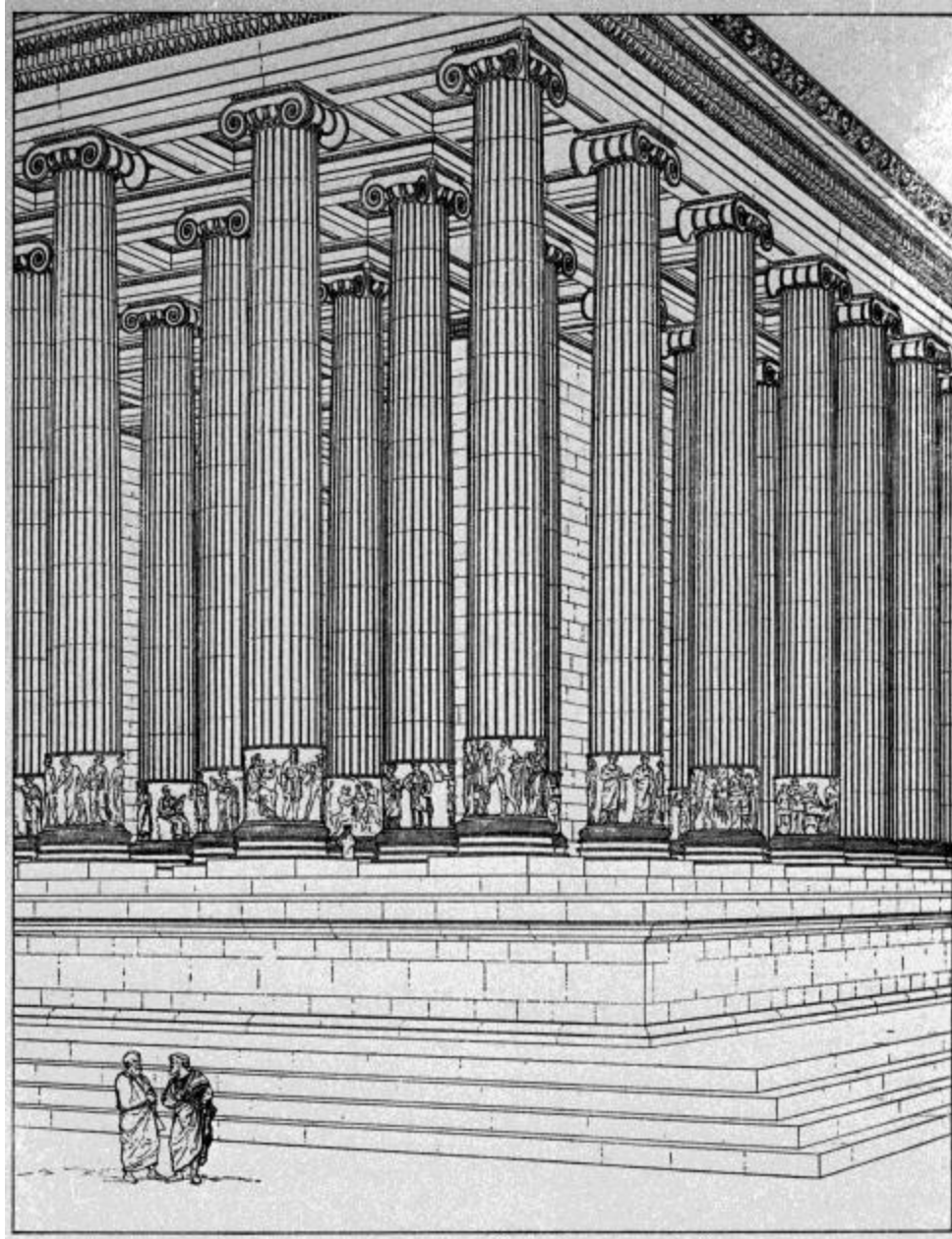

ΝΑΟΣ ΤΗΣ ΑΡΤΕΜΗΣ ΛΕΥΚΟΦΡΥΗΝΗΣ,
ΜΑΓΝΗΣΙΑ ΕΠΙ ΜΑΙΑΝΔΡΩ

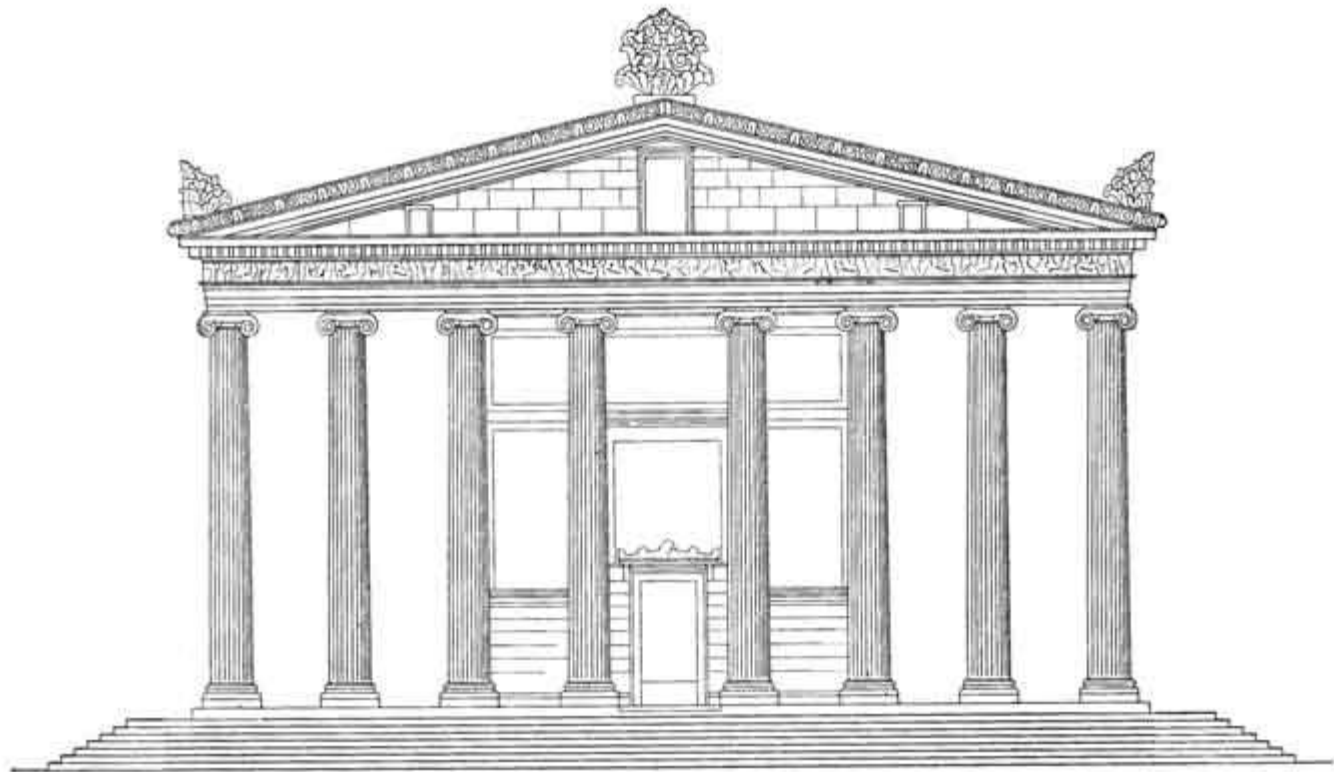



ΝΑΟΣ ΔΙΔΥΜΑΙΟΥ
ΑΠΟΛΛΩΝΟΣ
ΜΙΛΗΤΟΣ



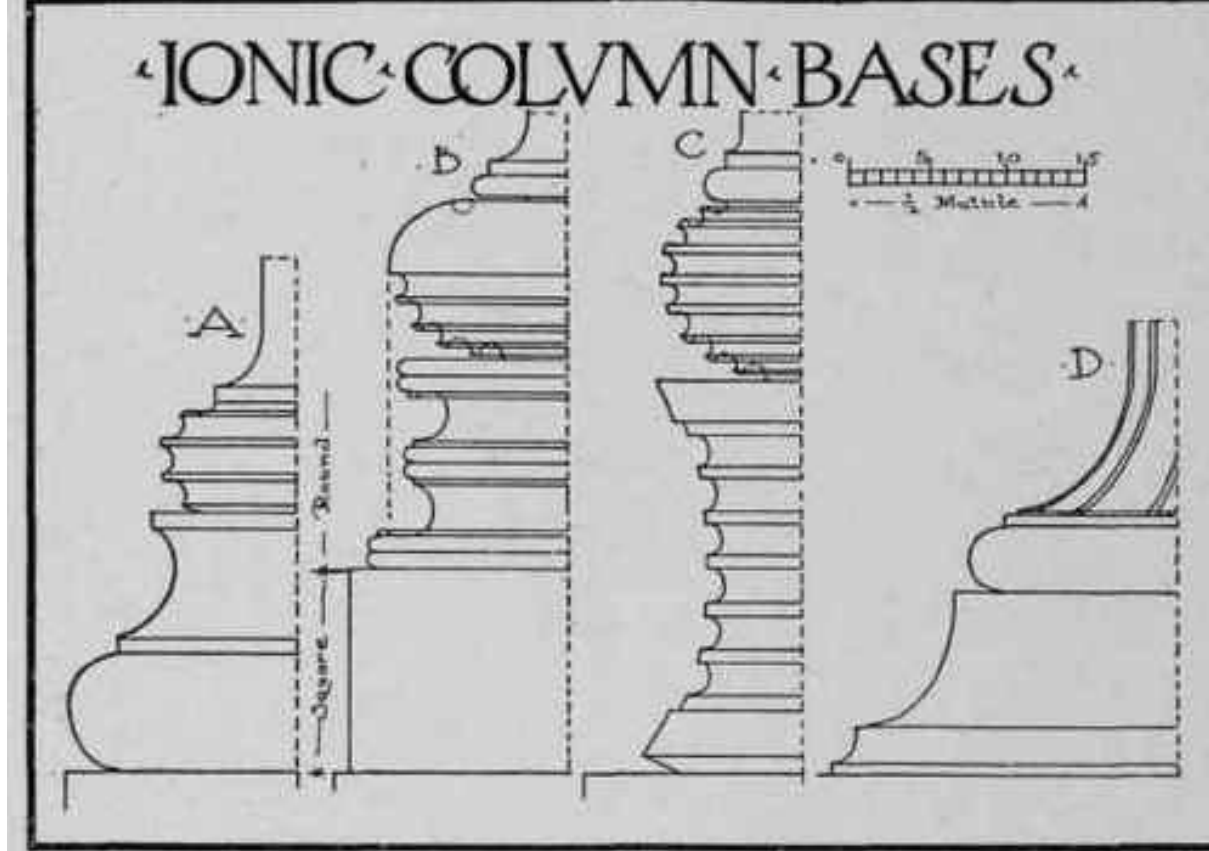

- Α ΑΤΤΙΚΗ ΒΑΣΗ (ΜΕΤΑ ΤΟ ΕΡΕΧΘΕΙΟ)
- Β ΕΦΕΣΙΑΚΗ ΒΑΣΗ
- C ΣΑΜΙΑΚΗ ΒΑΣΗ
- D ΠΕΛΟΠΟΝΝΗΣΙΑΚΗ ΒΑΣΗ (ΝΑΟΣ ΑΠΟΛΛΩΝΟΣ ΣΤΙΣ ΒΑΣΣΕΣ)

The image shows a close-up of ancient stone architecture. Two prominent, fluted columns stand on a raised platform. The columns are made of light-colored stone and feature a decorative base with a fluted section. Behind them is a wall constructed from large, rectangular stone blocks. The scene is illuminated by warm, golden light, likely from the setting or rising sun, casting long shadows. In the foreground, a metal railing is visible, and a small, light-colored rectangular plaque rests on the ground near the base of the columns.

ΝΗΣΙΩΤΙΚΗ ΒΑΣΗ

ΤΡΟΠΑΙΟ ΣΤΟΝ ΜΑΡΑΘΩΝΑ



Η ΣΑΜΙΑΚΗ ΒΑΣΗ

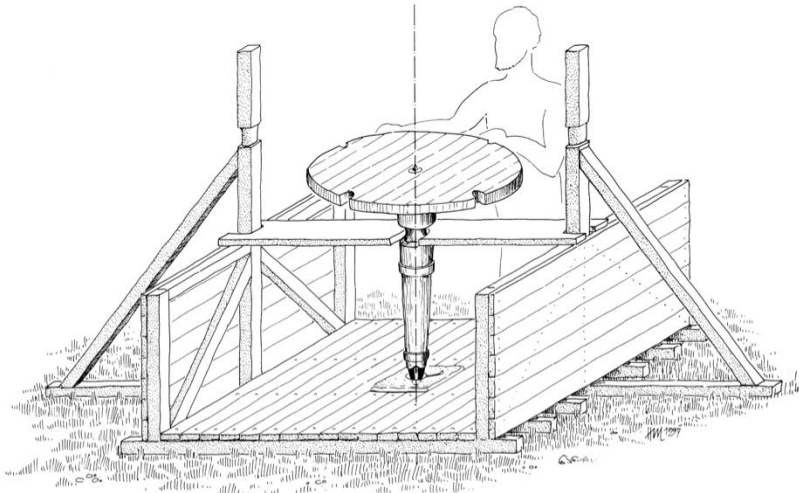

Rekonstruktion des Tornos

Rekonstruktion des Werkvorgangs

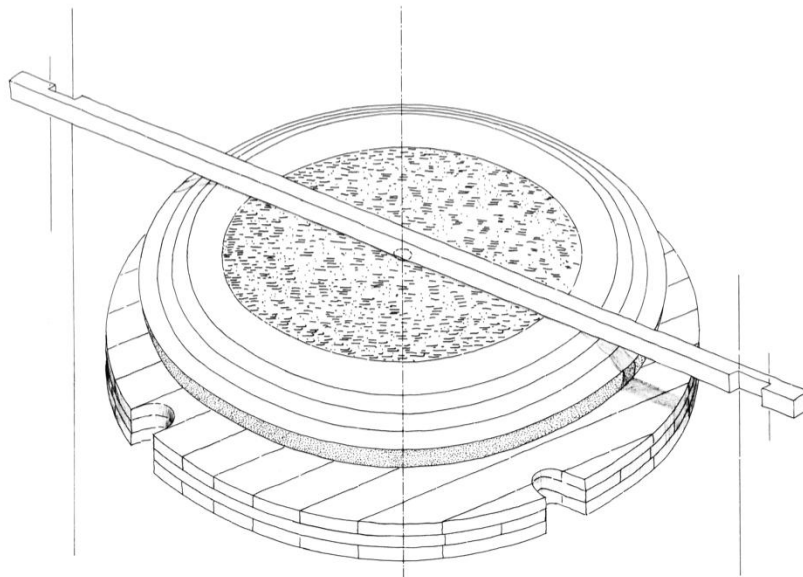
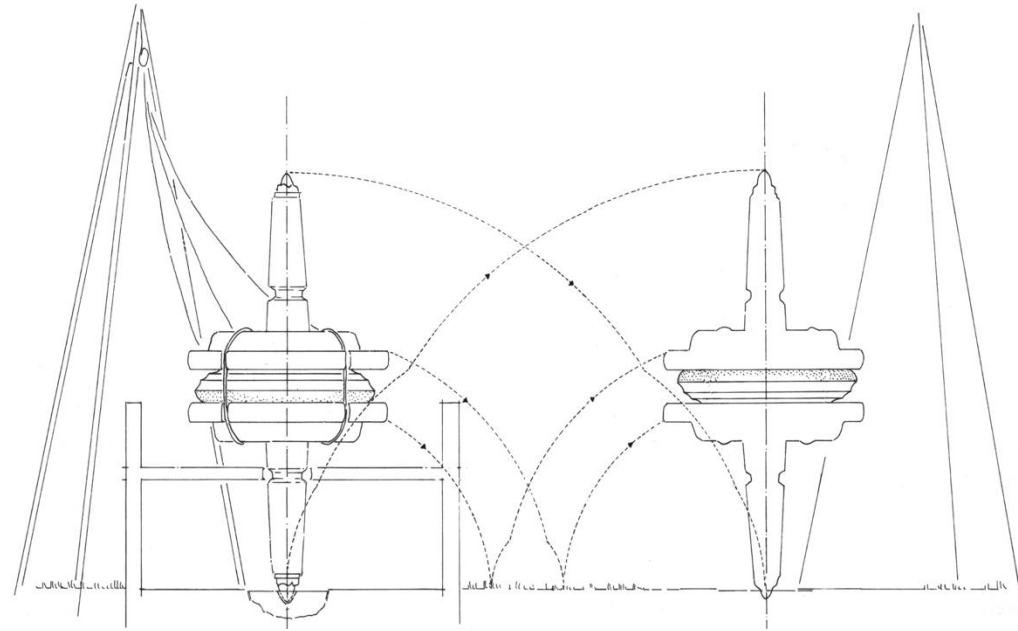

Werkstück auf der Drehscheibe mit in das Zentrierloch einrastender Anlegeschiene

Ionische Säulenbasen des 6 Jhs vChr

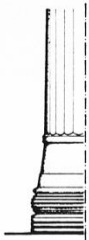

Naukratis, Apollon-T
um 566 v Chr.
(W.M. Flinders Petrie)



Delphi, Säule d. Naxier
um 570 v Chr.
(G. Kaster)



Delos, Oikos d. Naxier
um 600 v Chr.
(Innenraum, P. Courbin)

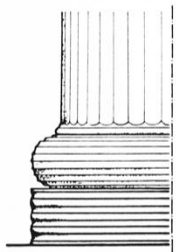

Samos, I Dipteros
um 560 v Chr.
(H. Johannes)

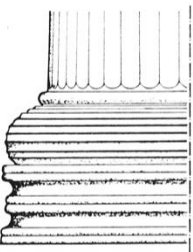

Ephesos, alte Artemision
um 550 v Chr.
(F. Krischen)

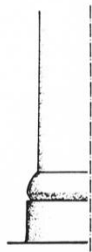

Delos, Oikos d. Naxier
um 550 v Chr.
(Prostylos, P. Courbin)

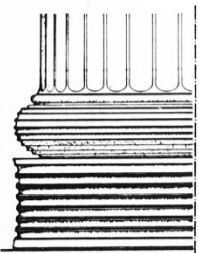

Samos, II Dipteros
um 530 v Chr.
(Pronaos)

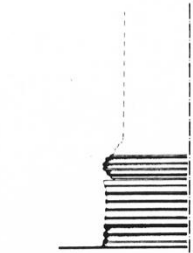

Chios, Phanai
um 500 v Chr.
(Fragmente, W. Lamb)



Naxos, Sangri
um 530 v Chr.
(G. Gruben)

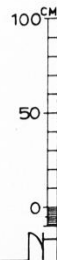

ΙΩΝΙΚΟΙ ΚΙΟΝΕΣ

- ΡΑΔΙΝΕΣ ΑΝΑΛΟΓΙΕΣ
- ΧΩΡΙΣ ΕΝΤΑΣΗ ΣΤΟΥΣ ΚΟΡΜΟΥΣ
- 24 (36) ΡΑΒΔΩΣΕΙΣ
- ΜΕ ΒΑΘΕΙΕΣ ΡΑΒΔΩΣΕΙΣ ΚΑΙ ΤΑΙΝΙΑ «ΑΡΡΙΣ»

* Ανομοιομορφία

Ποικιλία ραβδώσεων εντός του ίδιου μνημείου

Ναός Αρτέμιδος
Εφέσου.

Ναός Απόλλωνος
Δίδυμα Μιλήτου.

Ναός Ήρας Σάμου
(Πολυκράτη): εσωτερικό
και πτερό ναού

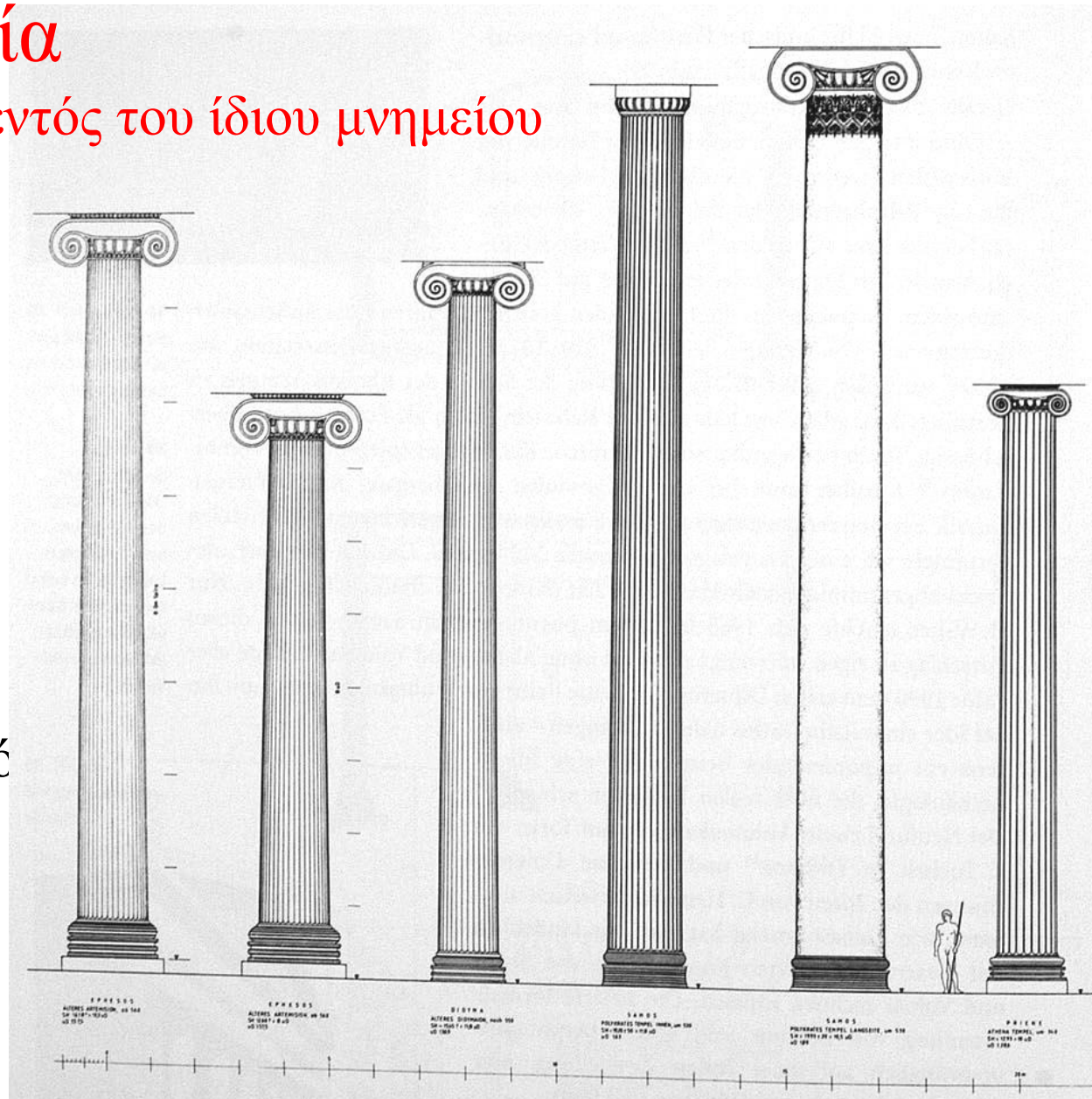





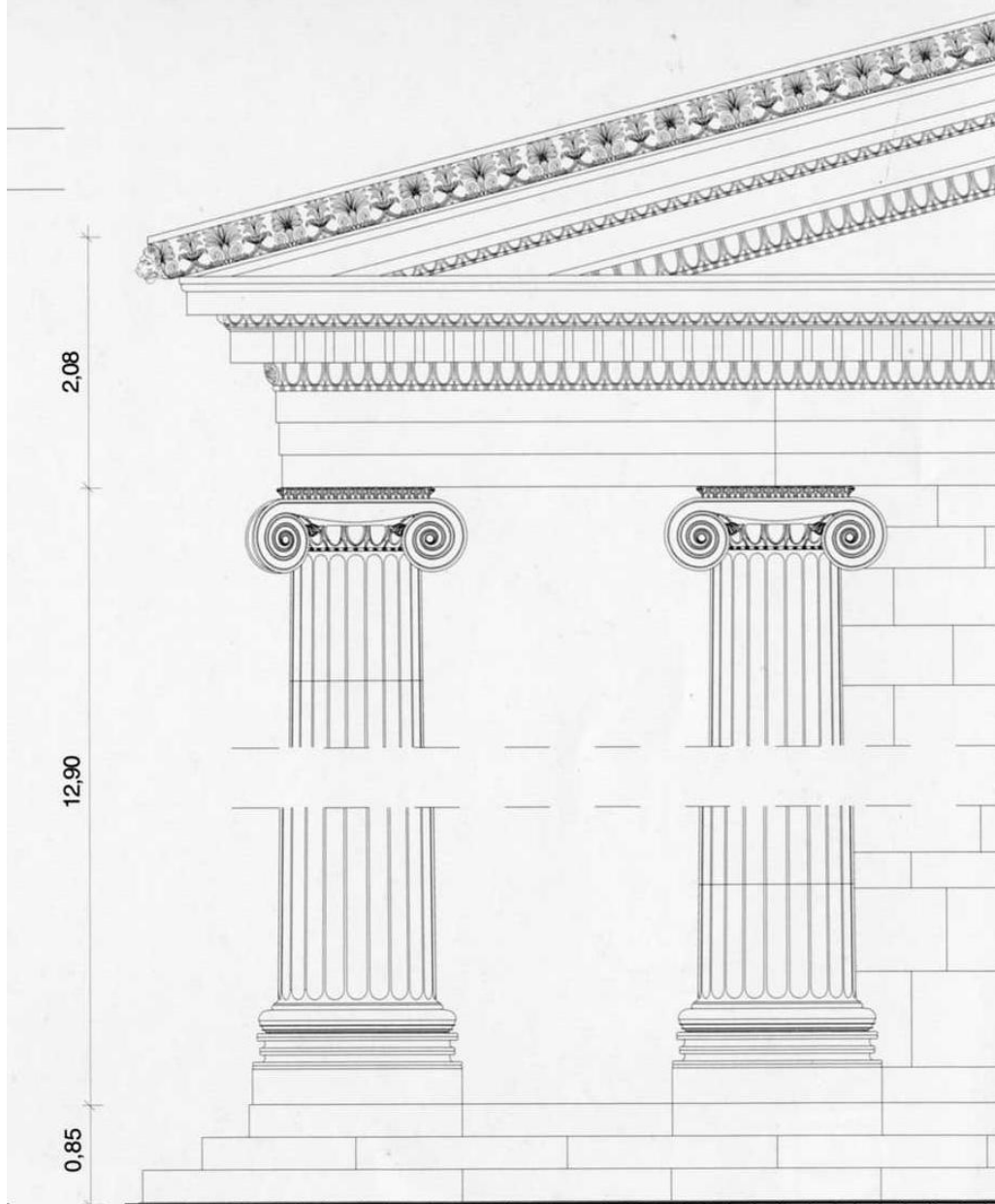

ΑΣΙΑΤΙΚΟΣ ΘΡΙΓΚΟΣ
Γεισήποδες

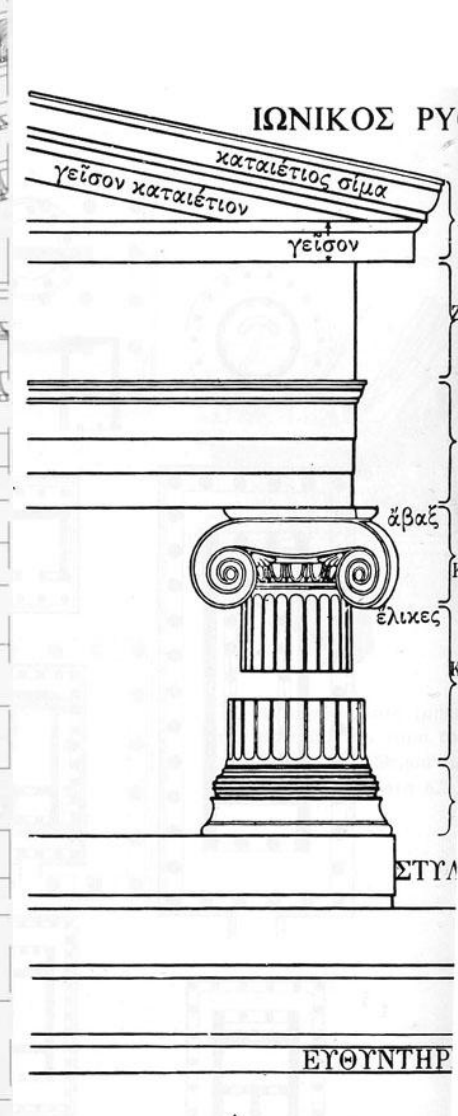

ΑΤΤΙΚΟΣ ΘΡΙΓΚΟΣ
Απλή ζωφόρος
(Κυκλάδες, Αθήνα)

ΑΕΤΩΜΑΤΙΚΑ ΓΛΥΠΤΑ



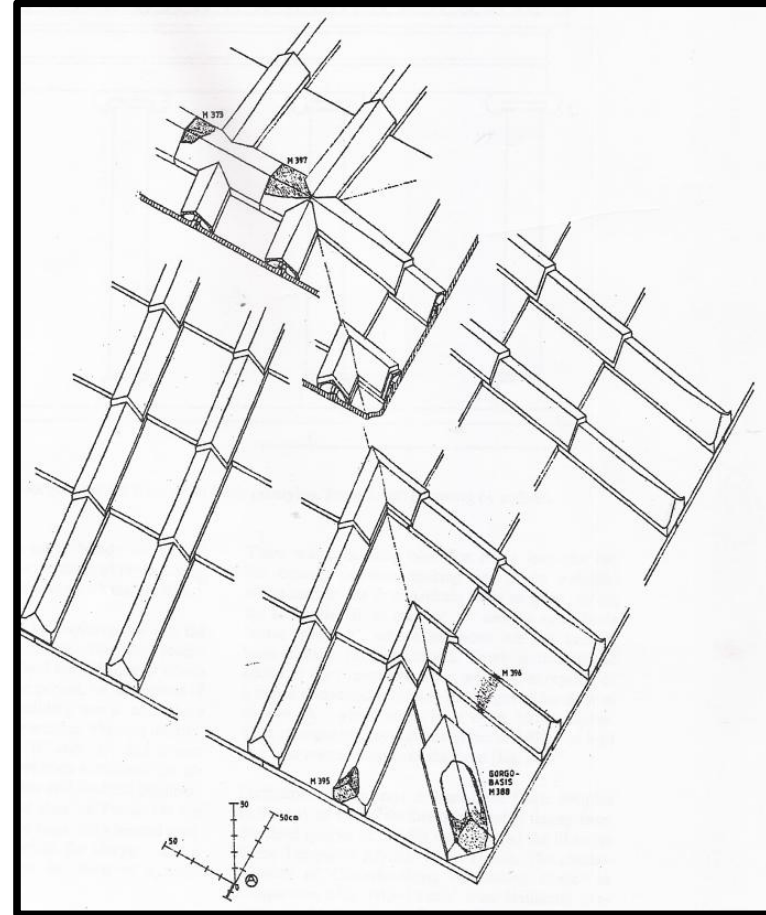
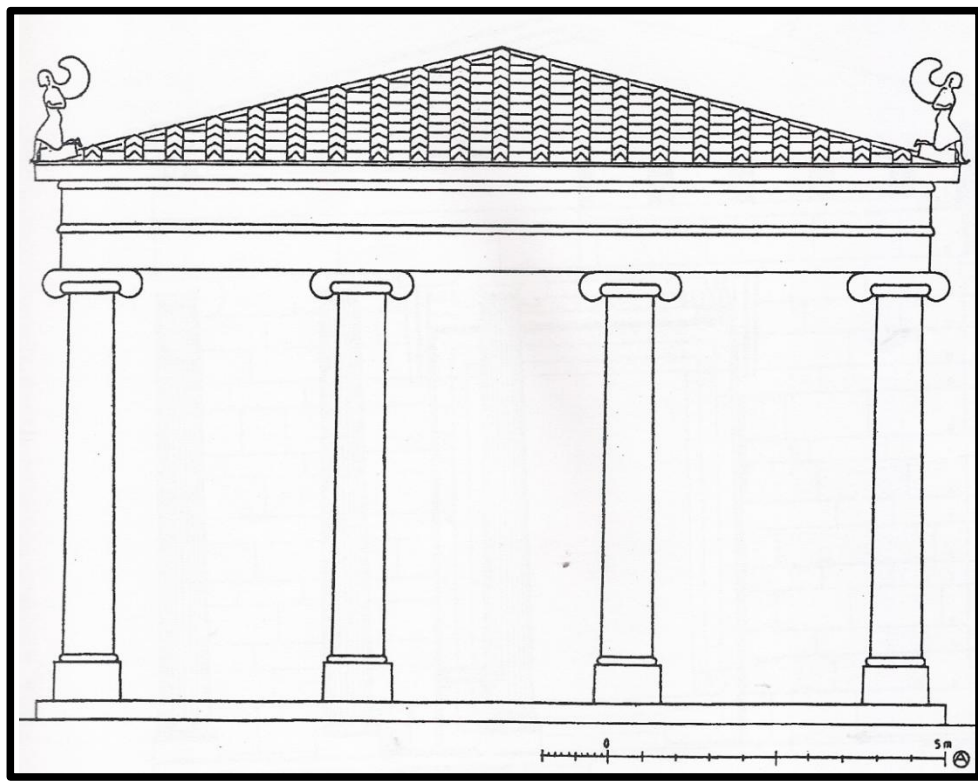

**ΑΠΟΥΣΙΑ
ΑΕΤΩΜΑΤΟΣ**

Πάρος. «Ναός Γοργούς» (υποθ. Ohnesorg)

ΨΕΥΔΟΪΣΟΔΟΜΗ ΤΟΙΧΟΔΟΜΙΑ «ΙΩΝΙΚΟΣ ΤΟΙΧΟΣ»

ΝΑΟΣ ΑΘΗΝΑΣ. ΠΑΡΟΣ, ΠΕΡ. 500 Π.Χ.

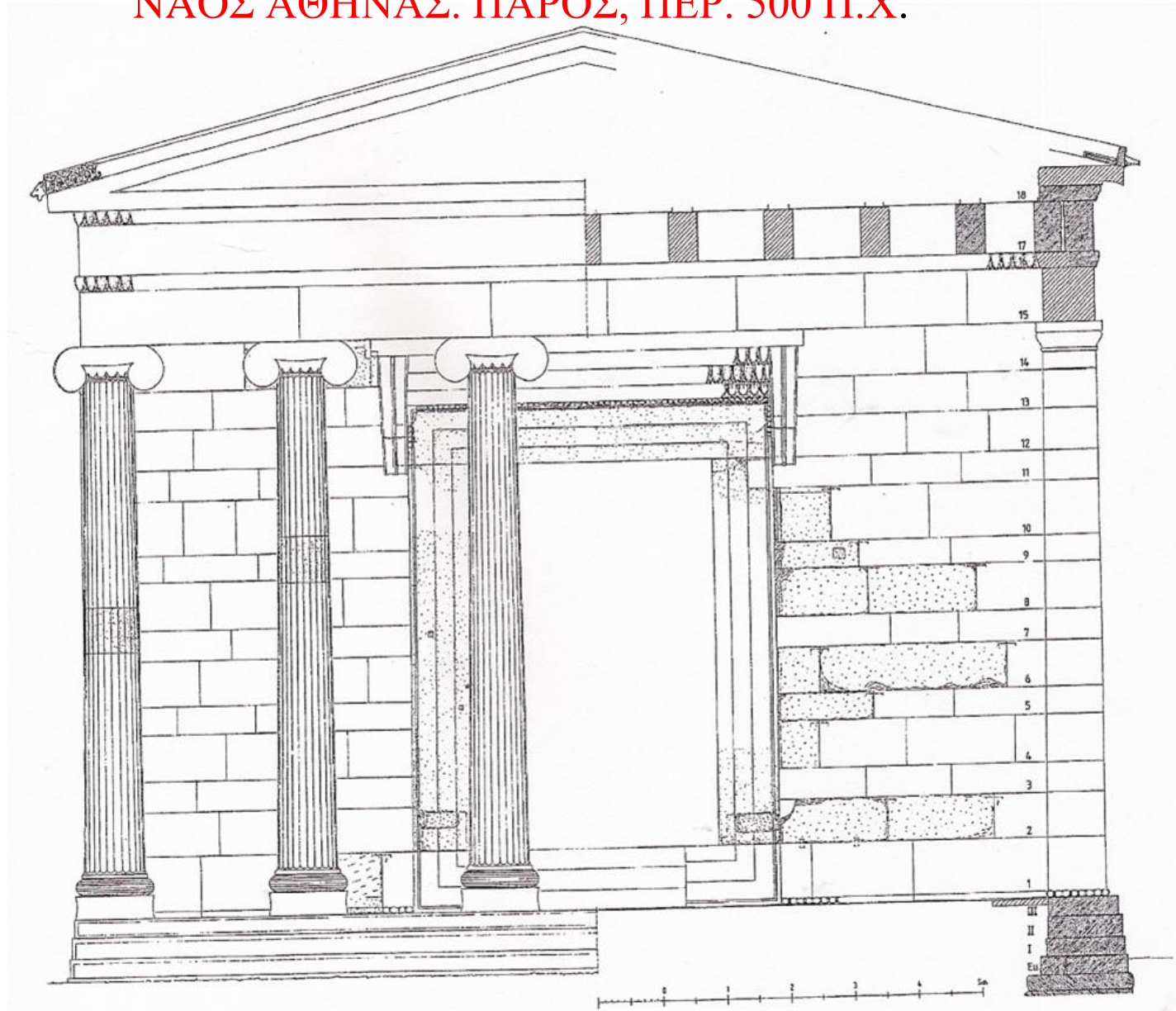

ΝΑΟΣ ΔΙΟΣ, ΠΡΙΗΝΗ

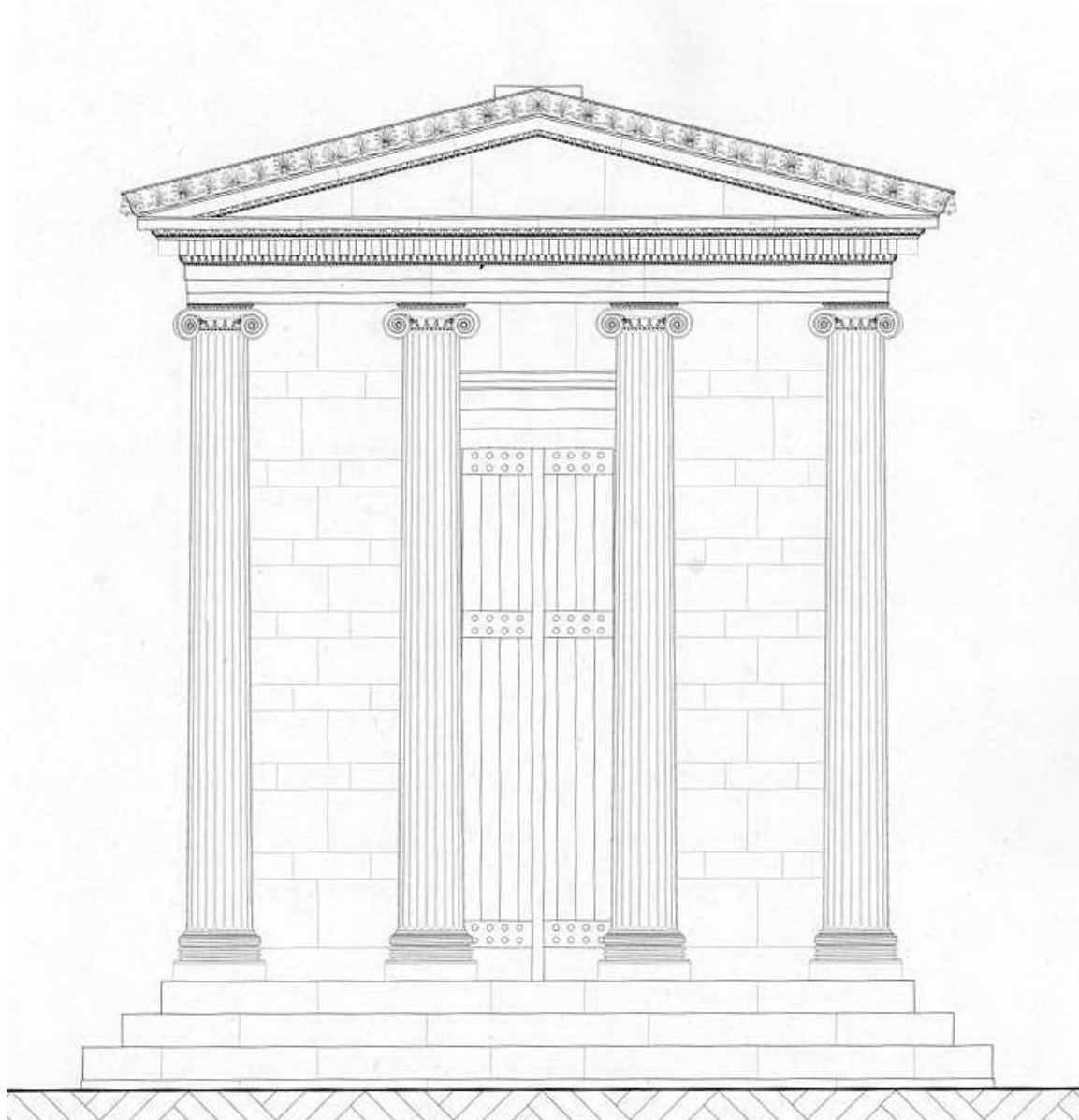

Η ΑΤΤΙΚΗ ΣΥΜΦΩΝΙΑ

- ΑΕΤΩΜΑ ΣΕ ΙΩΝΙΚΟ ΝΑΟ (Ναός Αθηνάς Νίκης)
- ΚΟΝΤΟΧΟΝΔΡΟΙ ΙΩΝΙΚΟΙ ΚΙΟΝΕΣ
- ΤΕΤΡΑΓΩΝΙΣΜΟΣ ΣΑΓΜΑΤΟΣ
- ΙΩΝΙΚΗ ΚΑΤΟΨΗ ΣΕ ΔΩΡΙΚΟ ΚΤΙΡΙΟ (Παρθενών)
- ΔΙΑΚΟΣΜΗΤΙΚΗ ΔΙΑΘΕΣΗ (ΜΕΤΟΠΕΣ ΣΕ ΔΩΡΙΚΟ ΚΤΙΡΙΟ)
- + ΝΗΣΙΩΤΙΚΑ ΙΩΝΙΚΑ ΣΤΟΙΧΕΙΑ

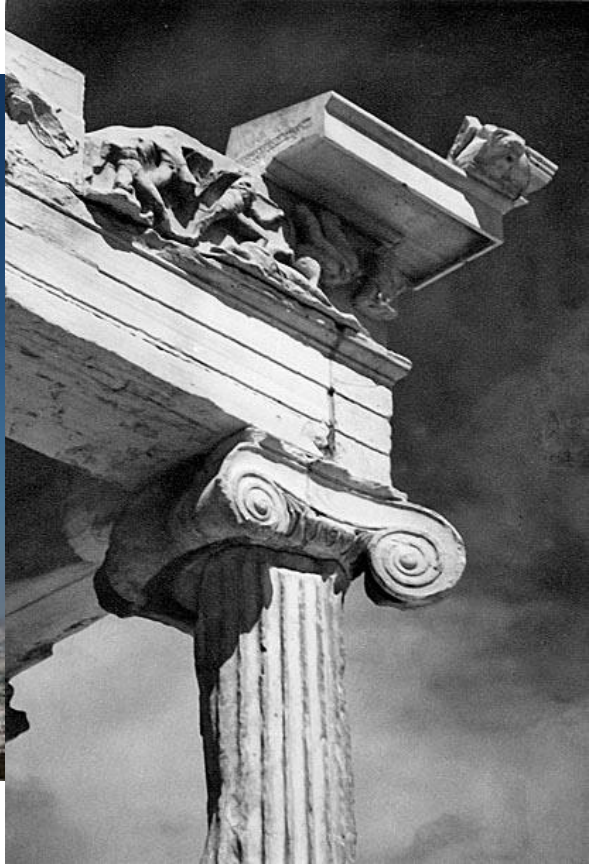

ΤΟ ΑΣΙΑΤΙΚΟ ΚΑΙ ΤΟ ΝΗΣΙΩΤΙΚΟ ΙΩΝΙΚΟ ΚΙΟΝΟΚΡΑΝΟ

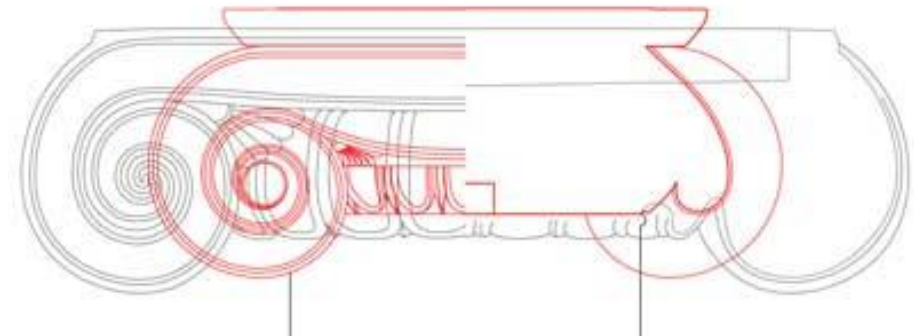
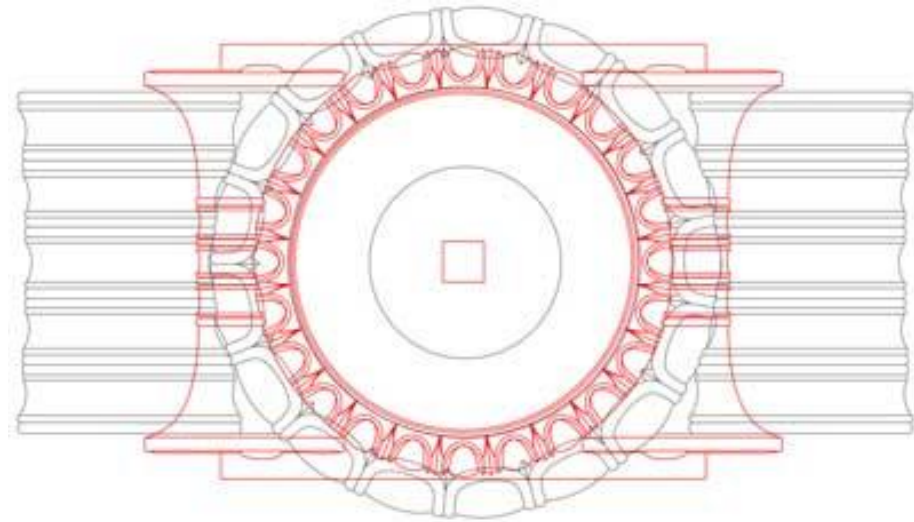
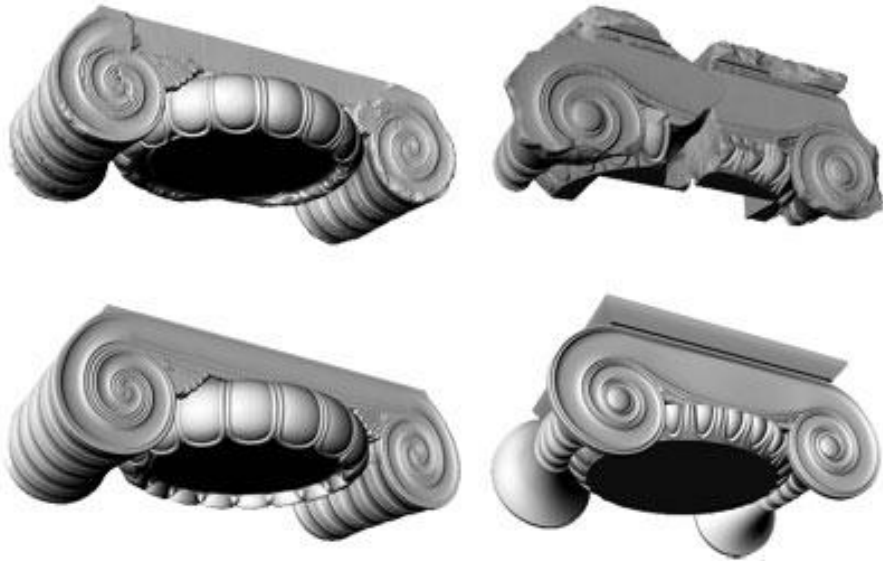

ΤΟ ΠΡΟΒΛΗΜΑ ΤΟΥ ΓΩΝΙΑΙΟΥ ΙΩΝΙΚΟΥ ΚΙΟΝΟΚΡΑΝΟΥ

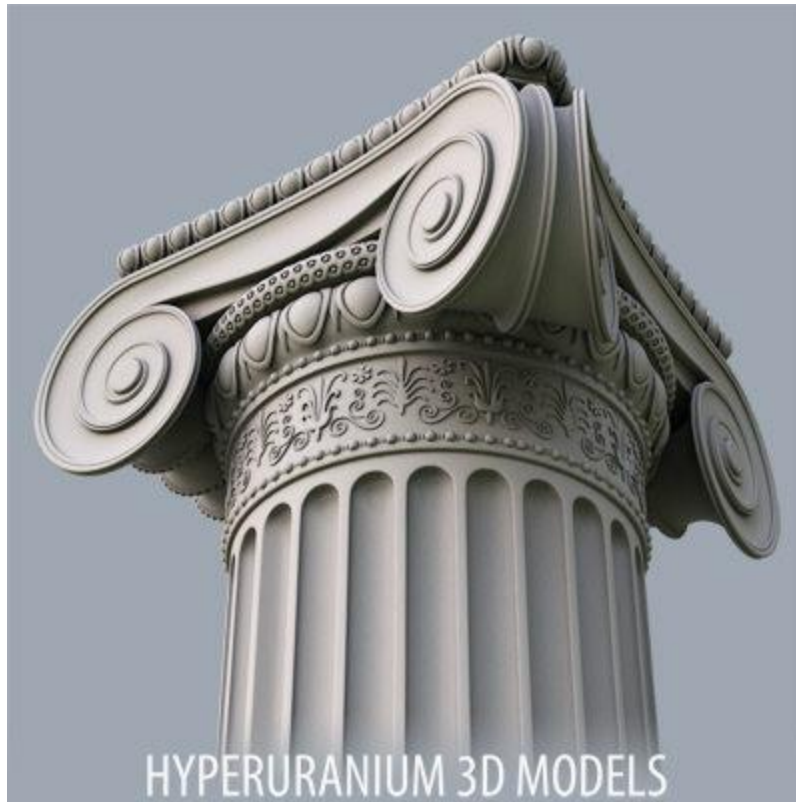

ΑΡΤΕΜΙΣΙΟ ΕΦΕΣΟΥ

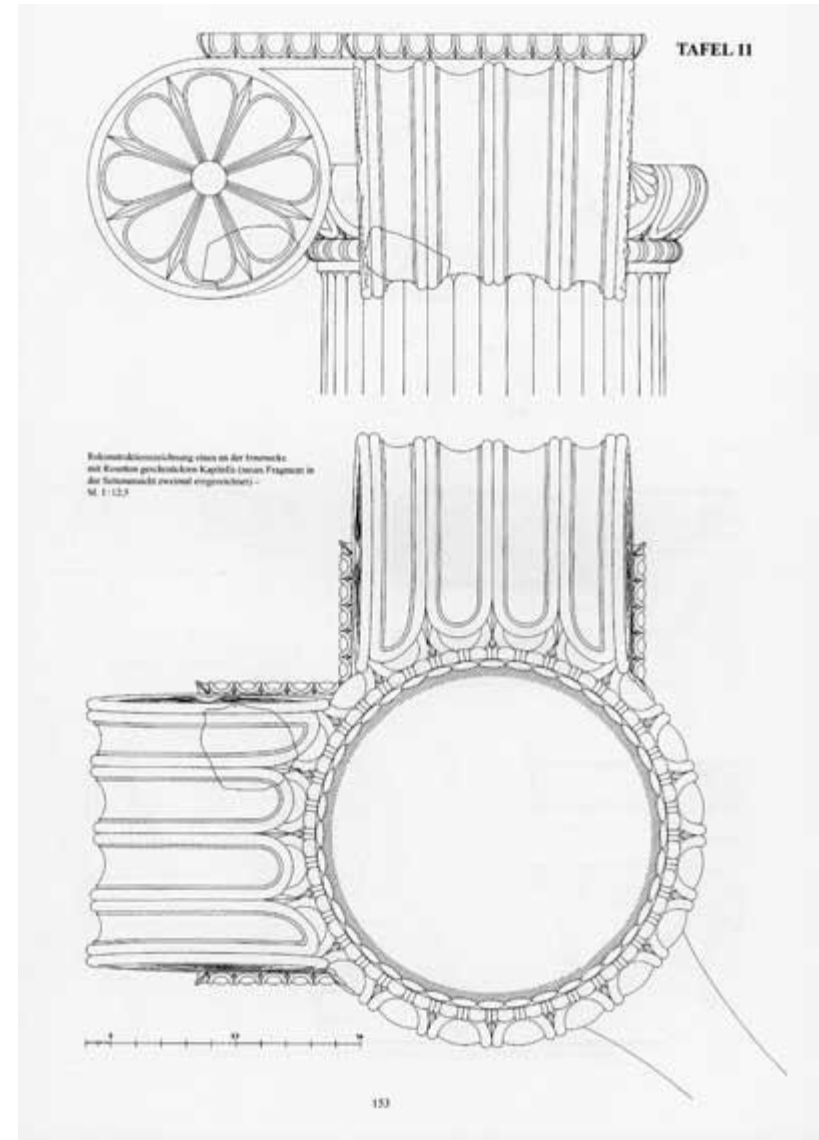

ΓΩΝΙΑΙΟ ΙΩΝΙΚΟ ΚΙΟΝΟΚΡΑΝΟ ΑΠΟ ΤΗΝ ΔΗΛΟ

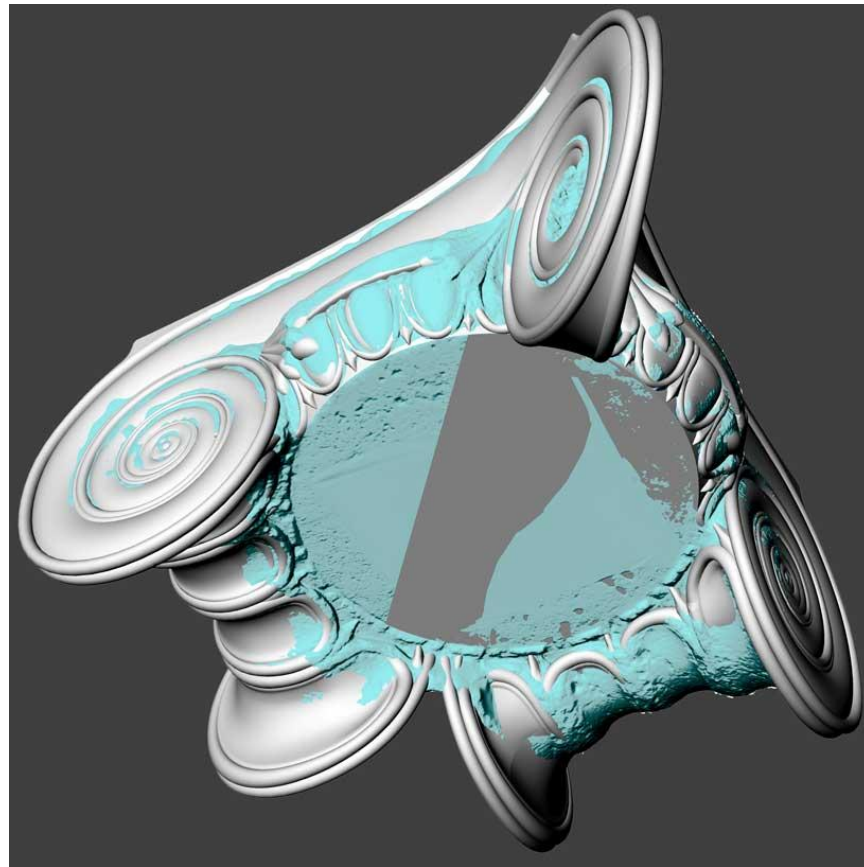

ΑΤΤΙΚΟ ΓΩΝΙΑΙΟ ΙΩΝΙΚΟ ΚΙΟΝΟΚΡΑΝΟ

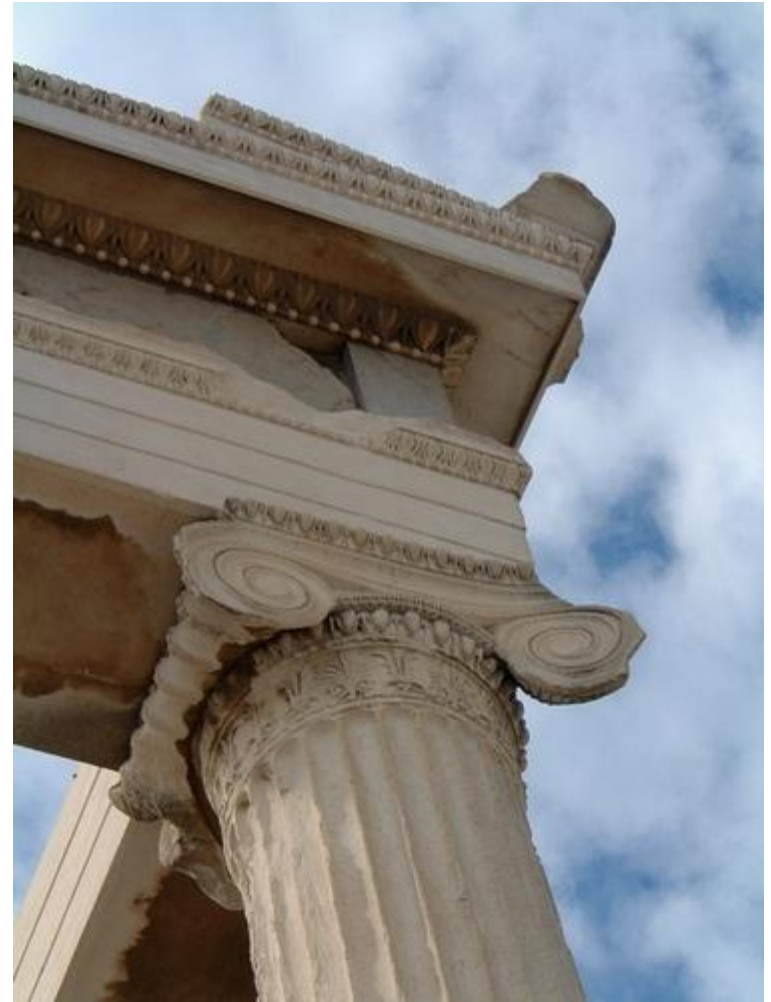
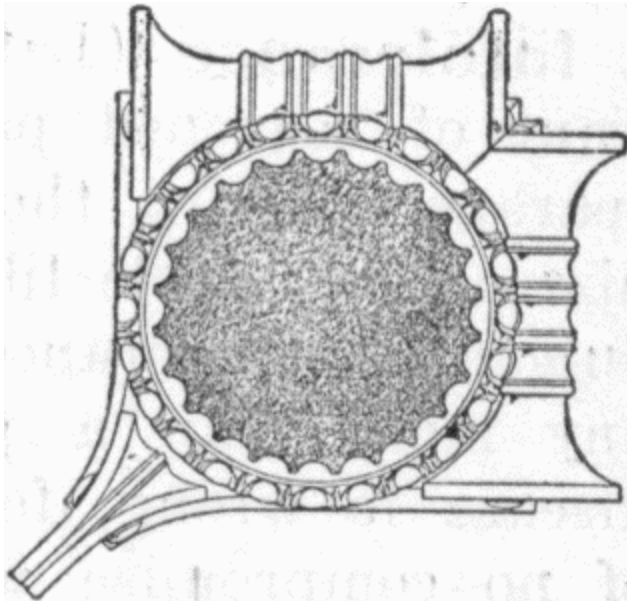

- ΜΕΙΞΗ ΡΥΘΜΩΝ
- ΚΑΘΎΨΟΣ ΣΤΙΣ ΣΤΟΞΣ
- ΣΤΟ ΙΔΙΟ ΕΠΙΠΕΔΟ ΣΤΟΑ ΠΟΣΕΙΔΩΝΟΣ