



---

The Stoa at the Amphiarraion, Oropos

Author(s): J. J. Coulton

Source: *The Annual of the British School at Athens*, Vol. 63 (1968), pp. 147-183

Published by: [British School at Athens](#)

Stable URL: <http://www.jstor.org/stable/30103187>

Accessed: 07/12/2010 15:04

---

Your use of the JSTOR archive indicates your acceptance of JSTOR's Terms and Conditions of Use, available at <http://www.jstor.org/page/info/about/policies/terms.jsp>. JSTOR's Terms and Conditions of Use provides, in part, that unless you have obtained prior permission, you may not download an entire issue of a journal or multiple copies of articles, and you may use content in the JSTOR archive only for your personal, non-commercial use.

Please contact the publisher regarding any further use of this work. Publisher contact information may be obtained at <http://www.jstor.org/action/showPublisher?publisherCode=bsa>.

Each copy of any part of a JSTOR transmission must contain the same copyright notice that appears on the screen or printed page of such transmission.

JSTOR is a not-for-profit service that helps scholars, researchers, and students discover, use, and build upon a wide range of content in a trusted digital archive. We use information technology and tools to increase productivity and facilitate new forms of scholarship. For more information about JSTOR, please contact [support@jstor.org](mailto:support@jstor.org).



British School at Athens is collaborating with JSTOR to digitize, preserve and extend access to *The Annual of the British School at Athens*.

<http://www.jstor.org>

# THE STOA AT THE AMPHIARAION, OROPOS

(PLATES 45-50)

## INTRODUCTION

THE long stoa at the Amphiaraion, Oropos, was excavated by the Greek Archaeological Society in 1884, 1886, and 1887, and received a preliminary description in *PAE* 1884, 93-4, pl. E. by Doerpfeld and in *PAE* 1887, 59-62 by Leonardos. A much fuller publication of the stoa by F. Versace appeared in *AM* xxxiii (1908) 247-72,<sup>1</sup> since when no detailed study of the building has been published. In view of the interest presented by certain features of the plan and orders of the building a close reconsideration of its original appearance and its stylistic affiliations seems worthwhile. For Versace's publication, though in many ways excellent, is insufficiently illustrated and does not treat satisfactorily some of the problems presented by the stoa. The present study, which attempts to shed further light on these problems and to supplement the description of Versace, is based, except where mentioned, on new drawings, plans, and measurements.

### Acknowledgements

A number of scholars have kindly helped me in my study of this building, and it is a pleasure to express my gratitude to them. I must thank V. G. Kallipolitis and N. Verdelis, successive Ephors of Antiquities for Attica, for permission to study the stoa, and to the Greek Archaeological Service for allowing me to publish this paper. B. Chr. Petrakos kindly read an early draft and his very useful suggestions have been

incorporated in the present version. Dr. W. H. Plommer, who also read through my work at various stages, has corrected many errors and I have benefited from numerous discussions with him. I am very grateful also to A. H. S. Megaw for his careful revision of my text and particularly for his help with the section on the roof of the stoa.

### Abbreviations

In addition to the normally accepted abbreviations, the following are used below:

<i>Anaktoro.</i>	M. Andronikos, G. Bakalakis, C. Makaronas, N. Moutsopoulos, Τὸ Ἀνάκτρον τῆς Βεργίνος.
<i>Assos</i>	J. Bacon, F. Clark, R. Koldewey, <i>Investigations at Assos.</i>
<i>Corinth</i>	<i>Corinth: Results of Excavations conducted by the American School of Classical Studies at Athens.</i>
<i>Délos</i>	École française d'Athènes, <i>Exploration archéologique de Délos.</i>
Doerpfeld <i>F. de D.</i>	<i>PAE</i> 1884, 93-4. École française d'Athènes, <i>Fouilles de Delphes.</i>
Heuzey-Daumet	L. Heuzey, H. Daumet, <i>Mission archéologique de Macédoine.</i>

Leonardos	<i>PAE</i> 1887, 59-62.
<i>Megalopolis</i>	E. A. Gardner <i>et al.</i> , <i>Excavations at Megalopolis</i> , 1890-1.
<i>Milet</i>	T. Wiegand, <i>Milet: Ergebnisse der Ausgrabungen und Untersuchungen seit dem Jahre 1899.</i>
<i>Olympia</i>	E. Curtius, F. Adler, <i>Olympia: die Ergebnisse der vom Deutschen Reich veranstalteten Ausgrabungen.</i>
<i>Priene</i>	T. Wiegand, M. Schrader, <i>Priene: Ergebnisse der Ausgrabungen und Untersuchungen in den Jahren 1895-98.</i>
Roux	G. Roux, <i>L'Architecture de l'Argolide aux iv et iii siècles avant J.-C.</i>
Shoe	L. T. Shoe, <i>The Profiles of Greek Mouldings.</i>
<i>Thasos, L'Agora I</i>	R. Martin, <i>Études thasiennes VI, L'Agora I.</i>
Versace	<i>AM</i> xxxiii (1908) 247-72.

<sup>1</sup> This contains a discussion of previous literature. There is little more to add; R. Martin mentions the stoa in the general study of the Greek stoa at the end of his *Recherches sur l'agora grecque*, 451, and G. Roux discusses some of the

peculiarities of its Doric and Ionic orders in *L'Architecture de l'argolide aux IV et III siècles av. J.-C.* 325, 335, 383, 384, 386.

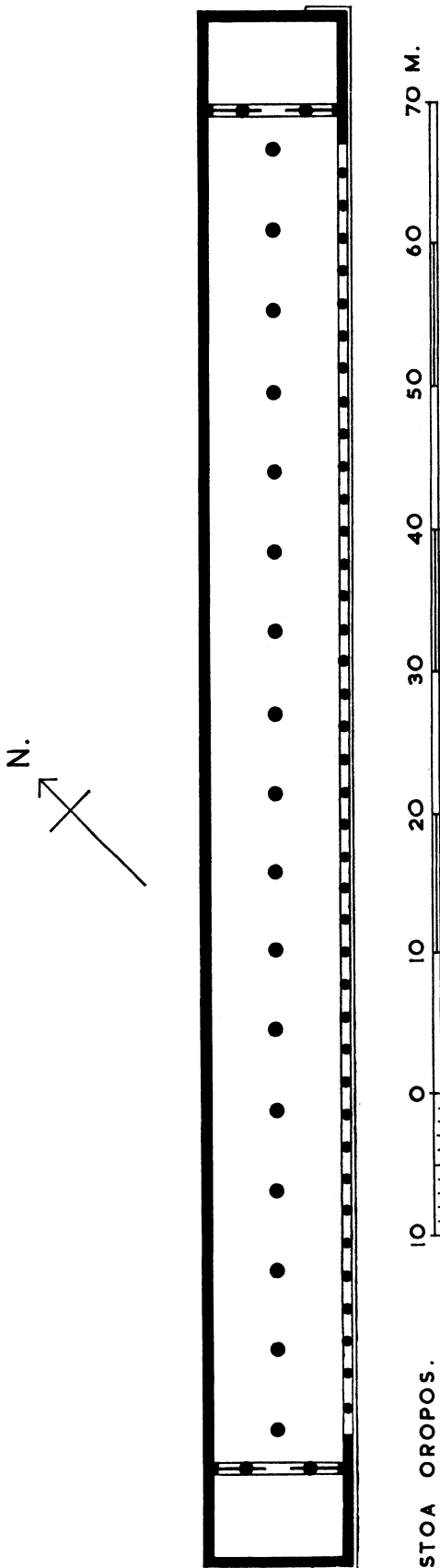

FIG. 1. PLAN OF THE STOA (SCALE 1 : 500)

## PART I. DESCRIPTION AND RESTORATION

*The Plan in General* (FIG. 1). The internal length of the stoa was 108.78 m.,<sup>2</sup> giving a stylobate length of 110.15 m. The width from the inner face of the back wall to the outer edge of the first step was 11.08 m., and so 10.78 m. to the outer edge of the stylobate. A row of seventeen Ionic columns divided the interior of the stoa into two aisles and a Doric colonnade ran along the greater part of the front of the building. At either end of the stoa, a small room about 5½ metres wide and 10 metres deep was separated from the main hall by a partition consisting of two columns connected by thin stone slabs. Such partitions could only have been useful if access to the rooms from the front of the stoa was also restricted. As we shall see, the end walls probably returned for some distance along the front of the stoa, so closing off the rooms on this side.

The colonnade of the stoa faces approximately south-east;<sup>3</sup> its long axis is almost parallel to the long axis of the Temple of Amphiaraos. The orientation of the stoa, as also presumably of the temple, was determined by the steep narrow valley in which the sanctuary lay. A long building such as this stoa could only be built with its long axis parallel to the line of the valley, and obviously it would be more suitable to have it facing south-east across the valley, rather than north-west towards the hillside.

*The Walls.* The back and side walls of the stoa, 0.65–0.67 m. wide, survive to a height of 1.80 m. in some places. The lower part consists of two rows of orthostates, the inner ones with vertical joints and smooth faces, but the outer ones in quarry-faced trapezoidal masonry. They are 0.61–0.63 m. high, except inside the south-west end room where they are *c.* 0.78 m. high (the junction was masked by the anta) (PLATE 45, *b*). No clamps are used, and the joints are closed only near the faces of the wall, the rest of the stone being trimmed roughly back (PLATE 46, *a*). The space between the two skins of masonry was filled with earth.

<sup>2</sup> 108.67 m. according to Versace (269). The two end walls are 0.66 to 0.67 m. wide and the stylobate projected *c.* 0.02 m. beyond them at each end.

<sup>3</sup> Doerpfeld, Leonardos, and Versace refer to the ends of the stoa as east and west, but it seems preferable to use the more accurate terms north-east and south-west.

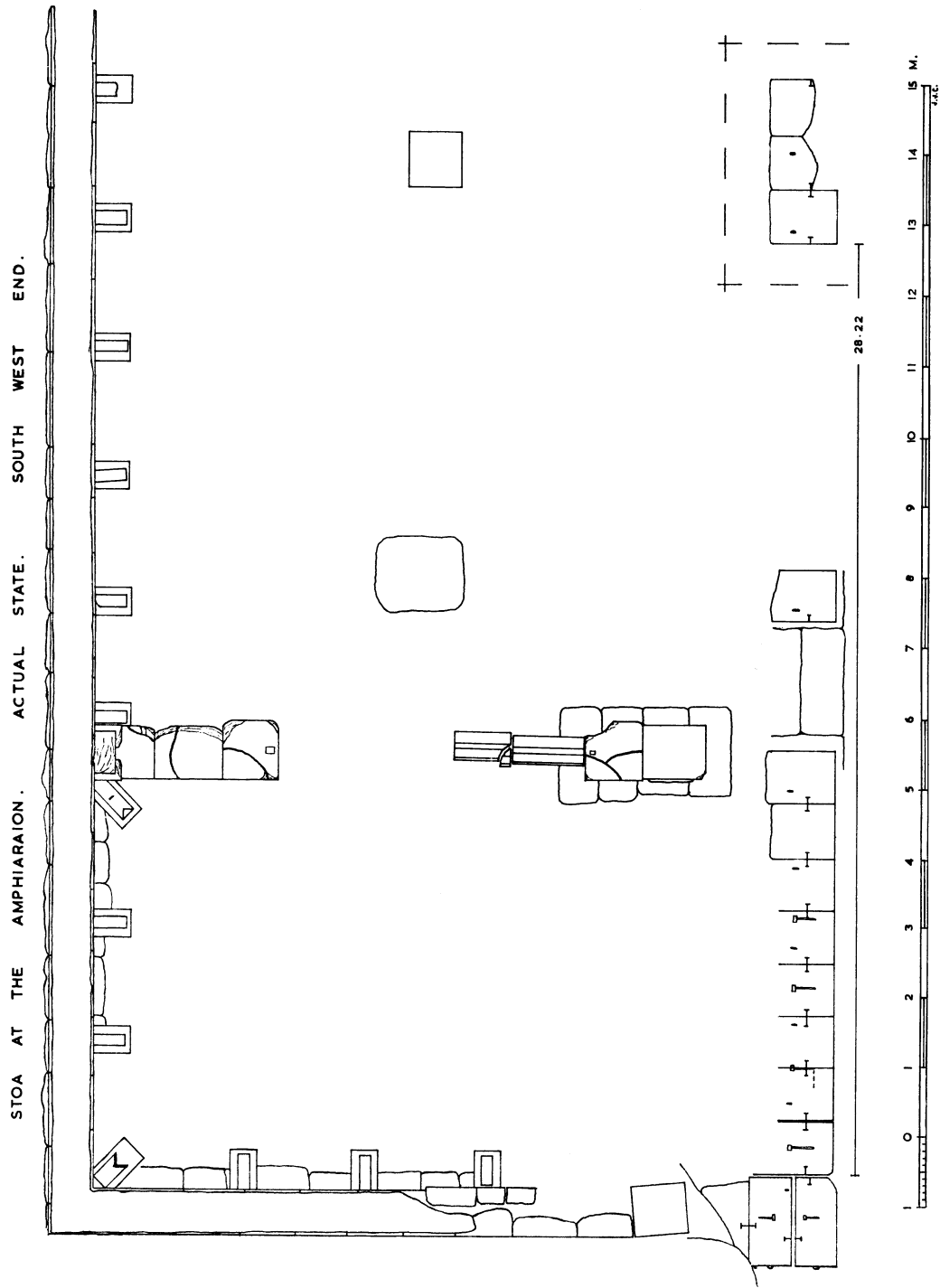

FIG. 2. PLAN OF THE ACTUAL STATE OF THE SOUTH-WEST END (SCALE 1 : 100)

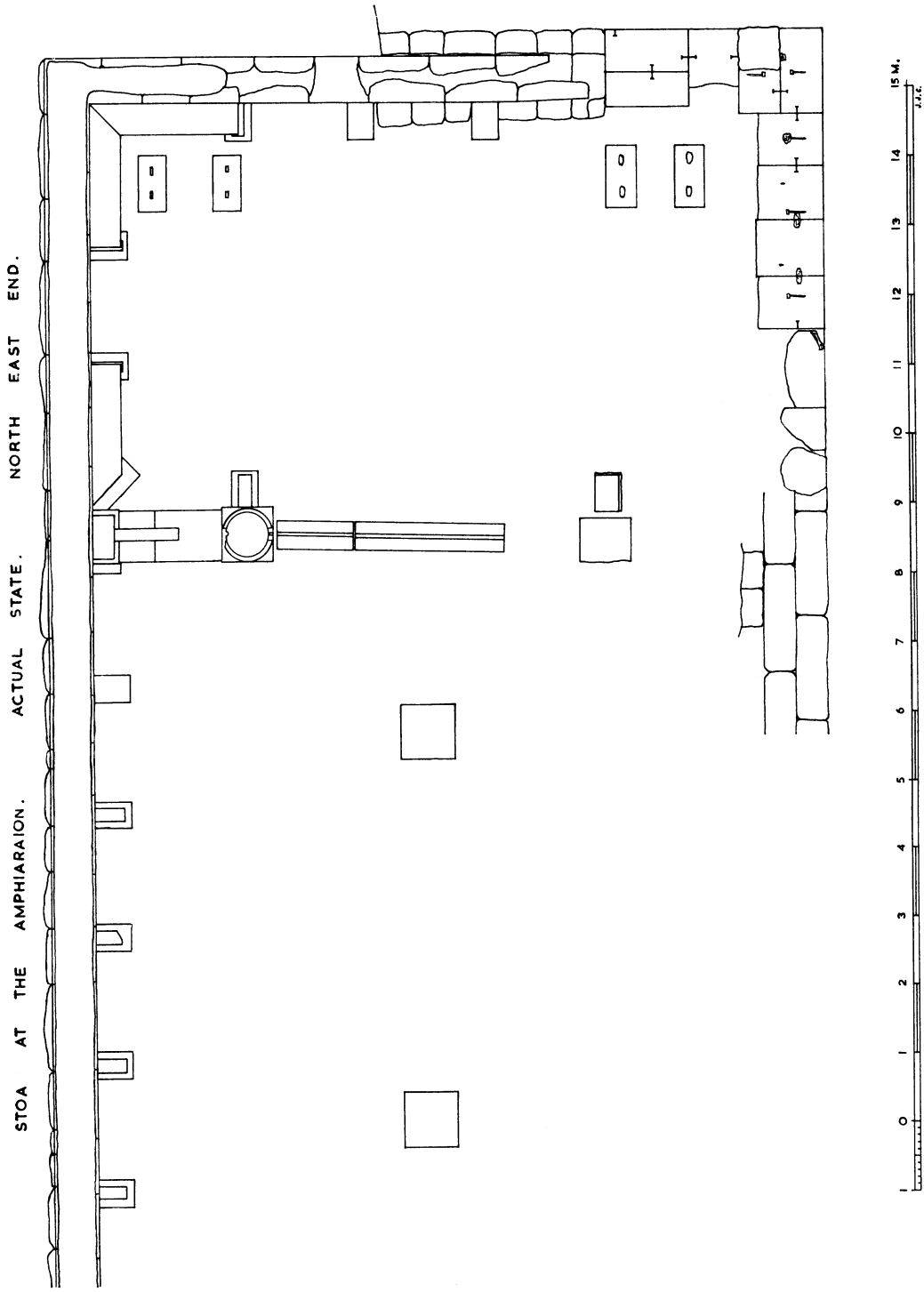

FIG. 3. PLAN OF THE ACTUAL STATE OF THE NORTH-EAST END (SCALE 1 : 100)

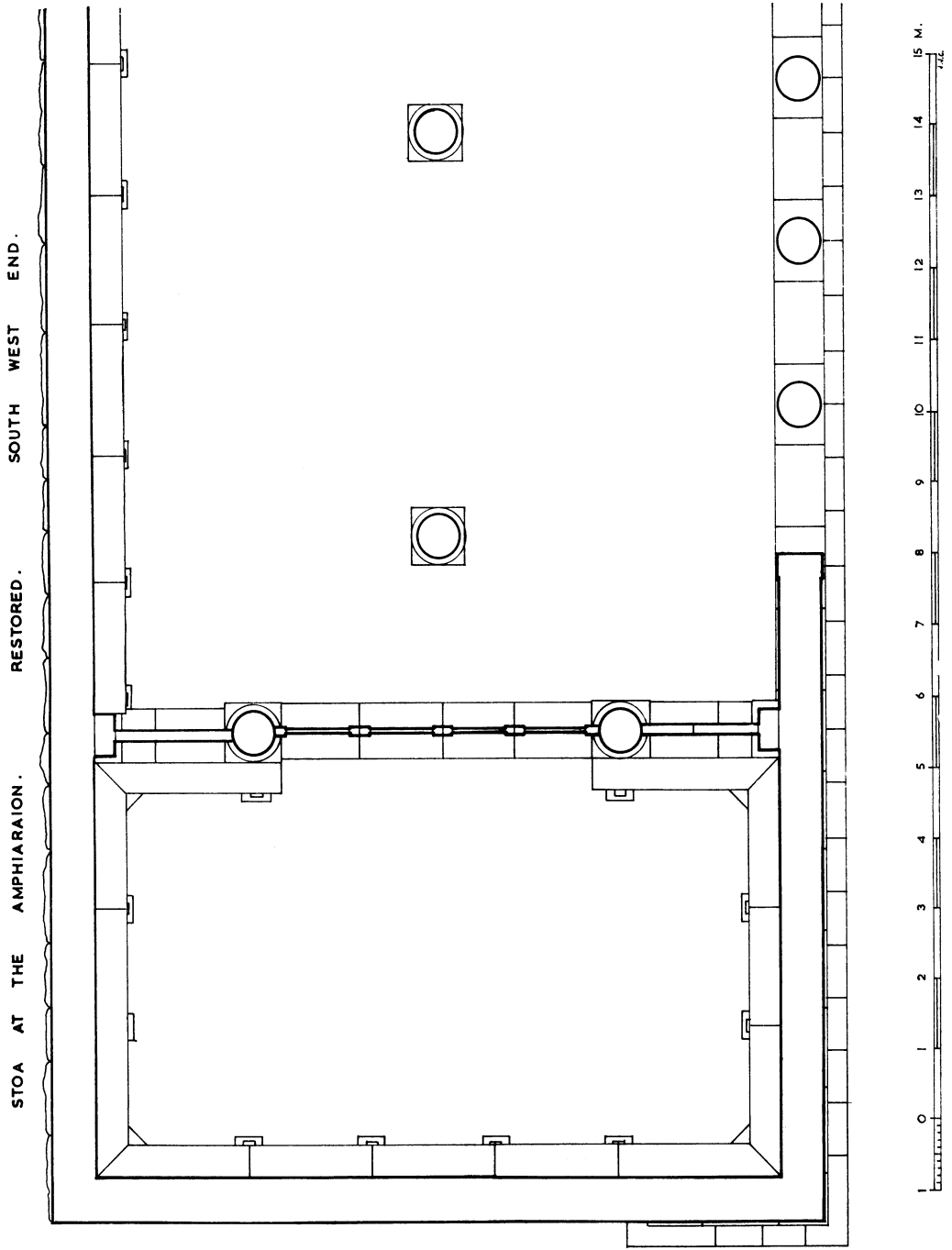

FIG. 4. RESTORED PLAN OF THE SOUTH-WEST END (SCALE 1 : 100)

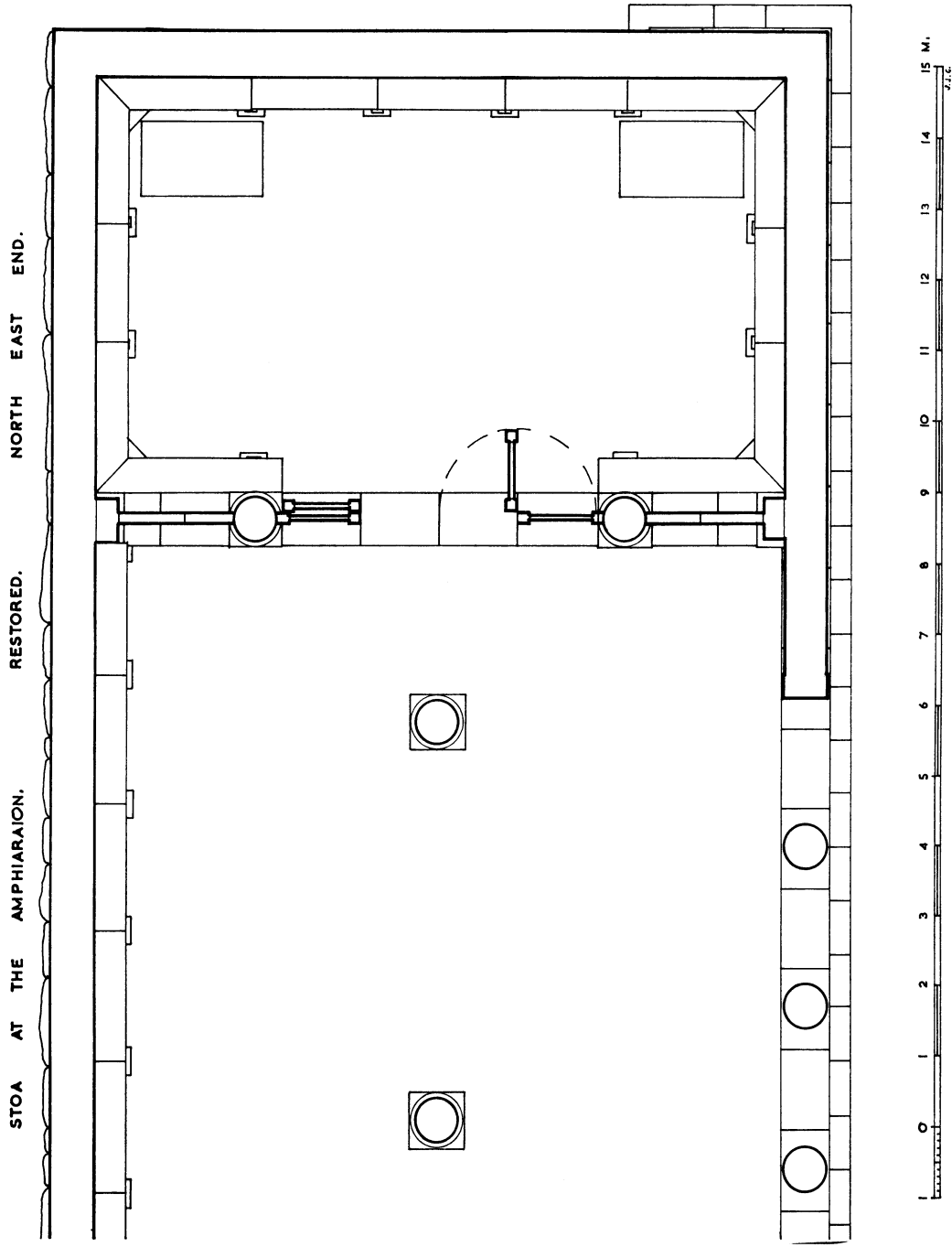

FIG. 5. RESTORED PLAN OF THE NORTH-EAST END (SCALE 1 : 100)

Above the orthostates the walls now consist of a rubble of stone and tile fragments set in a mud cement. The present material appears to belong to a later repair, since it contains a lot of broken tiles of late date; however, as there are no pry-holes in the tops of the orthostates the upper walls must always have been of some inferior material. It is not possible to say whether this was rubble or mudbrick.

*The Partitions* (FIGS. 2-5, PLATES 45 and 46). The two partitions which divided the end rooms from the main hall of the stoa are both better preserved towards the back of the building. Of the north-east partition, the lower part of an Ionic anta remains *in situ* against the rear wall. Above the base it is 0.63 m. wide and 0.335 m. deep, and it rests on a stylobate 0.755 m. wide which runs out from the back wall. The base of an Ionic column 0.63 m. in diameter (on the arrises) also stands on this stylobate, which widens to 0.80 m. beneath it to take the spreading base. The centre of the column is 2.34 m. from the inner face of the rear wall and 6.28 m. from the inner face of the end wall. A stone screen 0.175 m. thick originally ran between the anta and the column. A slab of it is still held in position in a cutting in the anta-base, and a similar cutting 0.19 m. wide in the column base held the adjoining slab. The other side of the column base also has a cutting 0.19 m. wide, as if the stone screen continued towards the centre of the stoa. If it did do so, the scheme was later changed, for the arrangement preserved is rather different.

In the south-west partition, the 0.80 m.-square block on which the corresponding Ionic column once stood, is also centred 2.34 m. from the rear wall; it lies 2.20 m. from the long axis of the stoa, and the same distance in front of the long axis is a similar 0.80 m.-square block, which presumably also bore an Ionic column. The partition therefore was symmetrical, and on the main façade of the stoa we should restore a wall in front of the end rooms with an anta backed against it. Access to the rooms would probably be through the partitions, making a proper door in the front wall unnecessary.

What happened between the two columns of each partition is less clear. As the stoa now stands, there is in the central part of each partition a line of long narrow stones forming a kind of threshold. They are of marble at the south-west end and of a rather poorly worked poros at the north-east. Along the top of each threshold runs a narrow groove, (0.08 m. wide at the south-west, 0.05 m. at the north-east), and in the square slabs on which the Ionic columns stood there are roughly cut holes which could have held the tenons of vertical wooden members running up beside the columns. The central intercolumniation must, at one time at any rate, have been closed by wooden shutters, consisting of separate planks placed in the groove at one end and slid along the groove until the whole doorway was closed. This is the normal method of closing shops in the Roman period,<sup>4</sup> and is found in the Hellenistic period in the 'Bazaar' at Assos.<sup>5</sup> The lintel which such a method of closure demands was in this case presumably of wood, supported by side-members set in the rough sockets mentioned above.

The blocks of the south-west threshold are reused seat slabs from the marble bench which was set up round the walls of the stoa (one block shows the curved front profile of the bench seat), and so obviously belong to a late repair or modification to the partition. The poros north-east threshold is more carelessly worked than the other original parts of the building, and the cuttings which took the vertical members connected with these thresholds are also poorly cut, so that it appears that none of these belong to the original scheme. The removal of the original blocks is easily explained, for since the central part would receive heavy wear from people using the rooms, it would naturally be the first part to need repair.

<sup>4</sup> e.g. in the Market of Trajan (partly visible in W. L. MacDonald, *The Architecture of the Roman Empire* i, pls. 85, 90, 92) and at Pompeii (A. Mau, *Pompeii in Leben und Kunst*

ed. 2 (1908) 287, figs. 147, 148, 157), and Ostia.

<sup>5</sup> Assos 103.



A central column in the partitions would have made it easier to roof the stoa, and it is tempting to restore one. In the later arrangement which survives, however, such a column was not found necessary, and there is no reason to believe the original builders less skilful at roofing. Further, if there were a central column, there would be no purpose in having the other two columns in each screen, since the stoa could easily be roofed in two spans. The architect must have wished the entrance to the end rooms to be central and so he used two columns instead of one central one.

As we have seen, the Ionic column *in situ* in the north-east partition has on the side facing the centre of the stoa a cutting in its base mouldings, which at first suggests that the stone screen continued further in this direction. But in that case it must have stopped somewhere in mid-intercolumniation to allow for the central doorway. There is however no parallel for this. At the South Stoa at Priene there is a stone screen between the columns and at one point there is a doorway through the screen.<sup>6</sup> But the screen at Priene is thicker, occupying half the thickness of the columns, and is built of blocks which bond in with the columns. At Oropos, where the screen consists of narrow stone slabs set on edge, it would be structurally unsound to leave one end unsupported by a column.

The barriers between the columns of the North Stoa at Assos<sup>7</sup> and at the east end of the North-west Stoa at Thasos,<sup>8</sup> have the same relative width as those at Oropos. In both cases the barrier ends with a column, and the doorway at Assos occupies a whole intercolumniation. Perhaps, therefore, the cutting in the Ionic column base mentioned above was made to take not a continuation of the stone screen, but the vertical member of a structure similar to that used later. In any case, unless further evidence appears, it is best to assume that the later builders did not change the arrangement of the screens unduly.

There is nothing to show how the central intercolumniation was closed originally. Its whole width would be unnecessarily wide for actual doors and doors so big, which would not be able to be folded back, would seriously interfere with the movement of passers-by. Perhaps there was a wooden partition only part of which could be opened, as suggested in FIGS. 4, 5, 14. Or perhaps a heavy curtain was hung between the two columns.

The height of the screen is a matter for conjecture. It is unlikely that it continued up to the full height of the columns, and Versace was probably right in supposing that it was just high enough to prevent people seeing into the end rooms, or about 2.5 to 3.0 m. This is paralleled by the inter-columnar screens of the Stoa by the Harbour at Miletos (height 2.10 m.),<sup>9</sup> the South Stoa at Priene (2.46 m.),<sup>10</sup> and the west end of the North-west Stoa at Thasos (2.935 m.).<sup>11</sup>

*The Krepis.* The uppermost foundation course, the only one visible today, consists of a double row of soft poros blocks about 1.50 m. long and 0.50 to 0.55 m. wide. On it rests the lower step of the krepis, 0.235 m. high. The blocks (not counting those at the corners) average 0.765 m. in length and are from 0.95 to 1.05 m. deep. They were all held together by H-clamps which were concealed by the stylobate above. The tread of this step was 0.30 m. as is shown by a weathering mark visible on one of the blocks. On the upper surface of the step-blocks can be seen the pry-holes used in setting the blocks of the stylobate (PLATE 49, *d*). The average distance between the pry-holes, which was also the average length of the stylobate blocks, is 1.14 m., two stylobate blocks thus having about the same length as three step blocks, so that a regular arrangement was obtained (cf. FIG 4).

Several blocks, also 0.235 m. high and with a length of about 1.14 m.<sup>12</sup> are to be seen on the

<sup>6</sup> *Priene* 191-2.

<sup>8</sup> *Thasos, L'Agora* I, 19-20, Plan C.

<sup>9</sup> *Milet* I. vi. 6.

<sup>7</sup> *Assos* 45.

<sup>10</sup> *Priene* 191-2.

<sup>11</sup> *Thasos, L'Agora* I, 23.

<sup>12</sup> Recognized by Doerpfeld, 93.

site of the stoa; these clearly belong to the stylobate, and one has the trace of a column visible on it. The top is dressed smooth and 0.71 m. from the front edge, the rear face drops down vertically for about 0.07 m., below which the block projects irregularly.

The front face of both step and stylobate has a groove 0.045 m. high and 0.005 m. deep running along the bottom. It is stopped at either end of the building, but there is no stop moulding as there is on the Echo Stoa and South Stoa at Olympia.<sup>13</sup> Above the groove each block has a central stippled panel surrounded by a smooth margin *c.* 0.04 m. wide; both panel and margin are in the same plane.

*The Internal Colonnade.* Along the middle of the stoa ran a row of Ionic columns (PLATE, 45 *a*) with bases of the same size and form as those of the partitions mentioned above. The end columns of this colonnade are centred 9.11 m. from the inner face of the end walls, and the normal axial intercolumniation is 5.66 m.<sup>14</sup> The axis of the colonnade is 5.06 m. from the inner face of the rear wall and 5.02 m. from the inner edge of the stylobate, i.e. within a couple of centimetres of the long axis of the stoa.<sup>15</sup>

*The External Colonnade.* One of the surviving stylobate blocks has a column trace centred on it, and another has a setting-line across the middle, so the external intercolumniation was presumably related to the stylobate block length. The exact length of the span is not, however, at once obvious, for initial estimates can be based on the width of the metopes and triglyphs ( $3 \times 0.318$  (av. trig. W.) +  $3 \times 0.456$  (av. met. W.) = 2.322 m.), on the length of a surviving architrave backer (*c.* 2.30 m.) or on the size of the step and stylobate blocks ( $3 \times 0.765 = 2.295$ ;  $2 \times 1.14 = 2.28$  m.). To suit these figures, we can subtract the setback of the end walls (0.04 m.) and the width of the odd triglyph (0.318 m.) from the stylobate length of the stoa (110.15 m.) and divide the result (109.792 m.) into 144 frieze units of 0.762 m., or 143 frieze units of  $\frac{109.792}{143} = 0.7677$  m., or 142 frieze units of  $\frac{109.792}{142} = 0.773$  m. Since the colonnade did not run the full length of the building, the number of frieze units need not be divisible by 3 so as to make up a whole number of intercolumniations; the solid walls at each end of the façade could have any number of frieze units.

Luckily, however, there is a way to test these figures. Presumably the stoa was symmetrical, so that the centre line of the stoa passed through either the axis of a column or the centre of an intercolumniation. The three isolated step blocks south-west of the centre of the stoa (FIG. 2) have pry-holes which indicate that there was a stylobate block with its centre 25.16 m. from the centre of the stoa; another presumably had its centre  $25.16 - 1.14 = 24.02$  m. from the stoa centre; and a column must have stood at the centre of one of these two blocks.

If there were 142 frieze units of 0.773 m., there would be 23 spans (or equivalent) and two odd frieze units on each side of the stoa centre, i.e. a column at the middle. Either 25.16 m. or 24.02 m. should, therefore, be exactly divisible by the relevant intercolumniation, i.e.  $3 \times 0.773$  m. Yet  $\frac{25.16}{3 \times 0.773} = 11$  with a deficit of 0.349 m., and  $\frac{24.02}{3 \times 0.773} = 10$  with a remainder of 0.83 m. If there were 143 frieze units of 0.7677 m., there would be  $23\frac{1}{2}$  spans (or equivalent) and one odd frieze unit on each side of the stoa centre, i.e. an intercolumniation at the middle.

<sup>13</sup> *Olympia*, Plates, Architecture pl. li; *Olympia Bericht* ii, 33, fig. 19.

<sup>14</sup> The figure given by Doerpfeld (93) is 5.71 m; this is followed by Leonardos (56) and Versace (269). Since Versace's figure for the total length of the stoa is very close to mine, he has to place the end columns of the central colonnade much closer to the end walls (pl. xii. 2). My

measurements for the intercolumniation varied from 5.59 to 5.68 m. with an average of 5.66 m.

<sup>15</sup> Where the wall returns along the front of the stoa, its inner face was probably set back *c.* 0.04 m. from the rear edge of the stylobate, thus making the axis of the central colonnade coincide exactly with the long axis of the stoa.

Either 25.16 m. or 24.02 m. should then be divisible exactly by, say,  $10\frac{1}{2}$  times the relevant intercolumniation. Yet  $\frac{25.16}{3 \times 0.7677}$  goes  $10\frac{1}{2}$  times with a remainder of 0.977 m.;  $\frac{24.02}{3 \times 0.7677}$  goes  $10\frac{1}{2}$  times with a deficit of 0.153 m. If, finally, there were 144 frieze units of 0.762 m., there would be 24 spans (or equivalent) on each side of the stoa centre, i.e. a column at the middle. In this case  $\frac{25.16}{3 \times 0.762}$  goes 11 times with a remainder of 0.014 m.;  $\frac{24.92}{3 \times 0.762}$  goes 10 times with a remainder of 1.16 m. Clearly, therefore, there were 144 frieze units of 0.762 m. along the front, giving an axial span of 2.286 m.<sup>16</sup> The surviving frieze units presumably indicate a larger span because the triglyphs in fact overlapped the metopes by more than a centimetre where two frieze blocks met.

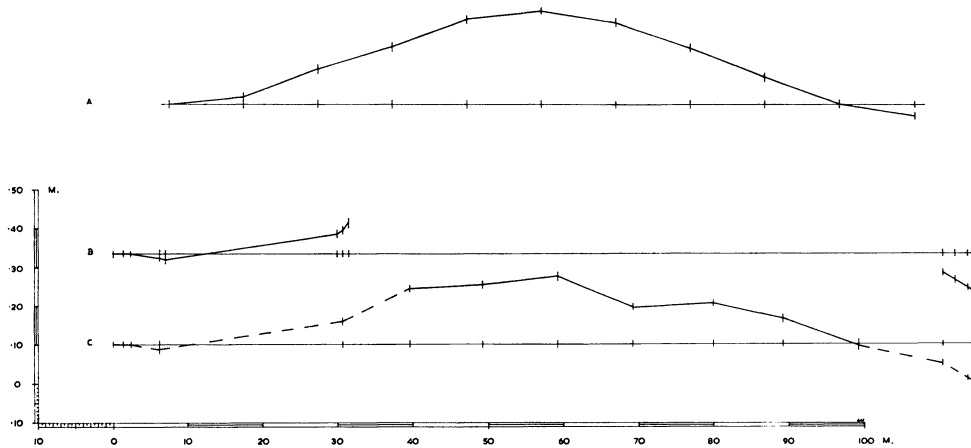

FIG. 6. HORIZONTAL CURVATURE IN THE STOA

- A. At the top of orthostates (central portico only).      B. At the top of the step blocks.  
 C. At the top of the eutyteria

(Horizontal scale 1 : 1000, vertical scale 1 : 20)

The main façade of the stoa consisted therefore of 48 intercolumniations or the equivalent, with a column set regularly on the centre of every second stylobate block. An isolated step block quite near the south-west end of the stoa which appears to disrupt this regularity is not *in situ*. We have seen that a wall must be restored at each end of this façade in front of the two end rooms. Versace gives each of those walls the length of three intercolumniations, but there is some awkwardness in having the anta which ends the Doric colonnade so close to the Ionic anta belonging to the cross partition.<sup>17</sup> It is more likely that this was avoided by making the walls along the front four intercolumniations in length (as shown in FIGS. 4-5). There is neither necessity nor suitable parallel for the pilasters with which Versace decorates his front walls, so that a façade with 39 columns between plain walls is most satisfactory along the south-east of the stoa (PLATE 50).

It is surprising to find that the spans of the external and internal colonnades are not related. Normally a relationship of two outer spans to each inner one was used,<sup>18</sup> but that is obviously

<sup>16</sup> This is the figure which Versace gives (269). Doerp-eld (93) and Leonardos (59) give 2.28 m.

<sup>17</sup> Versace, pl. xii. 2, xiii. 2.

<sup>18</sup> e.g. South Stoa, Argive Heraion; Stoa Basileios, Athens; South Stoa, Corinth; Stoa of Antigonos, Delos; Stoa of Attalos, Athens, etc.

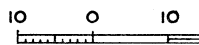
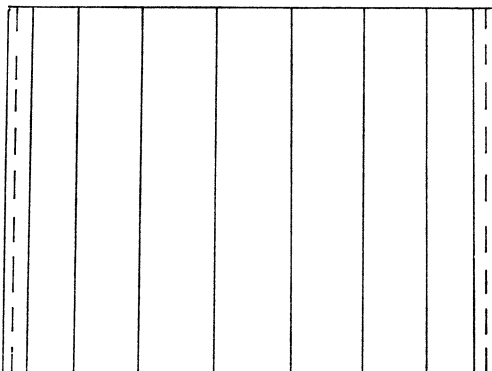
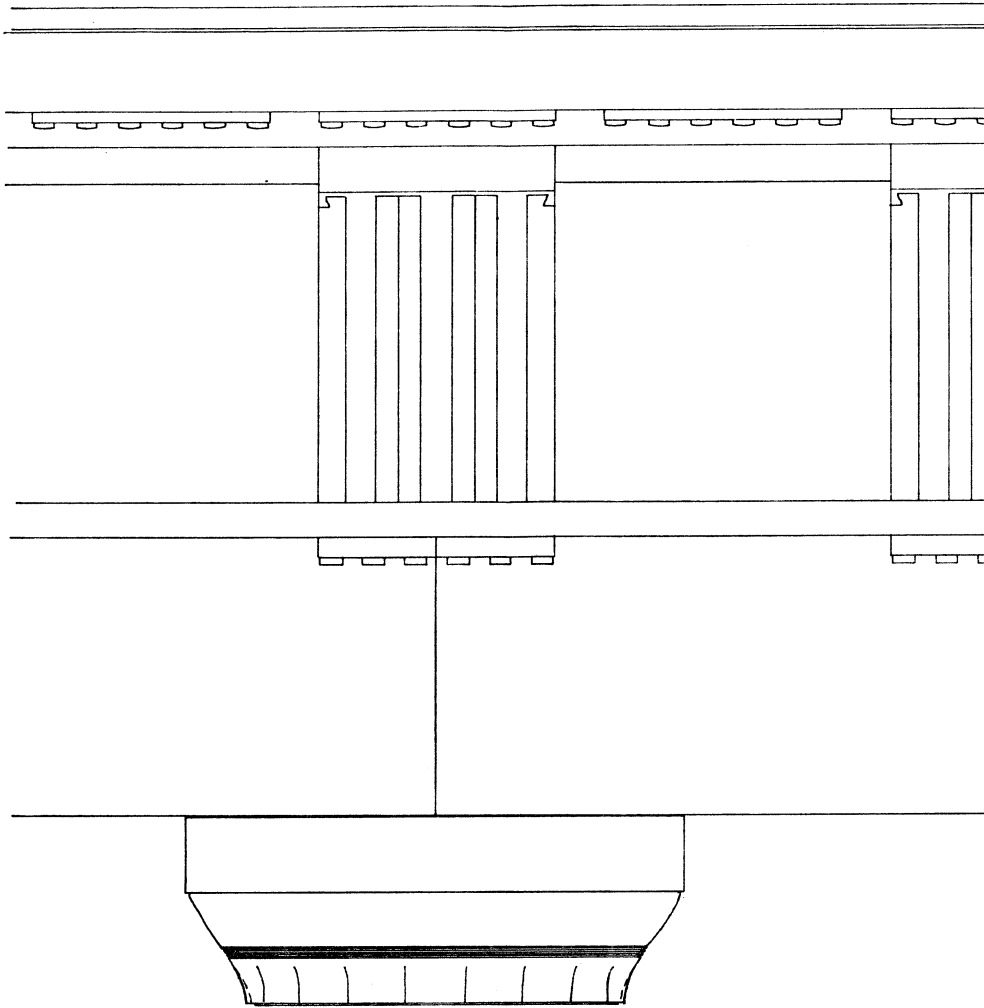

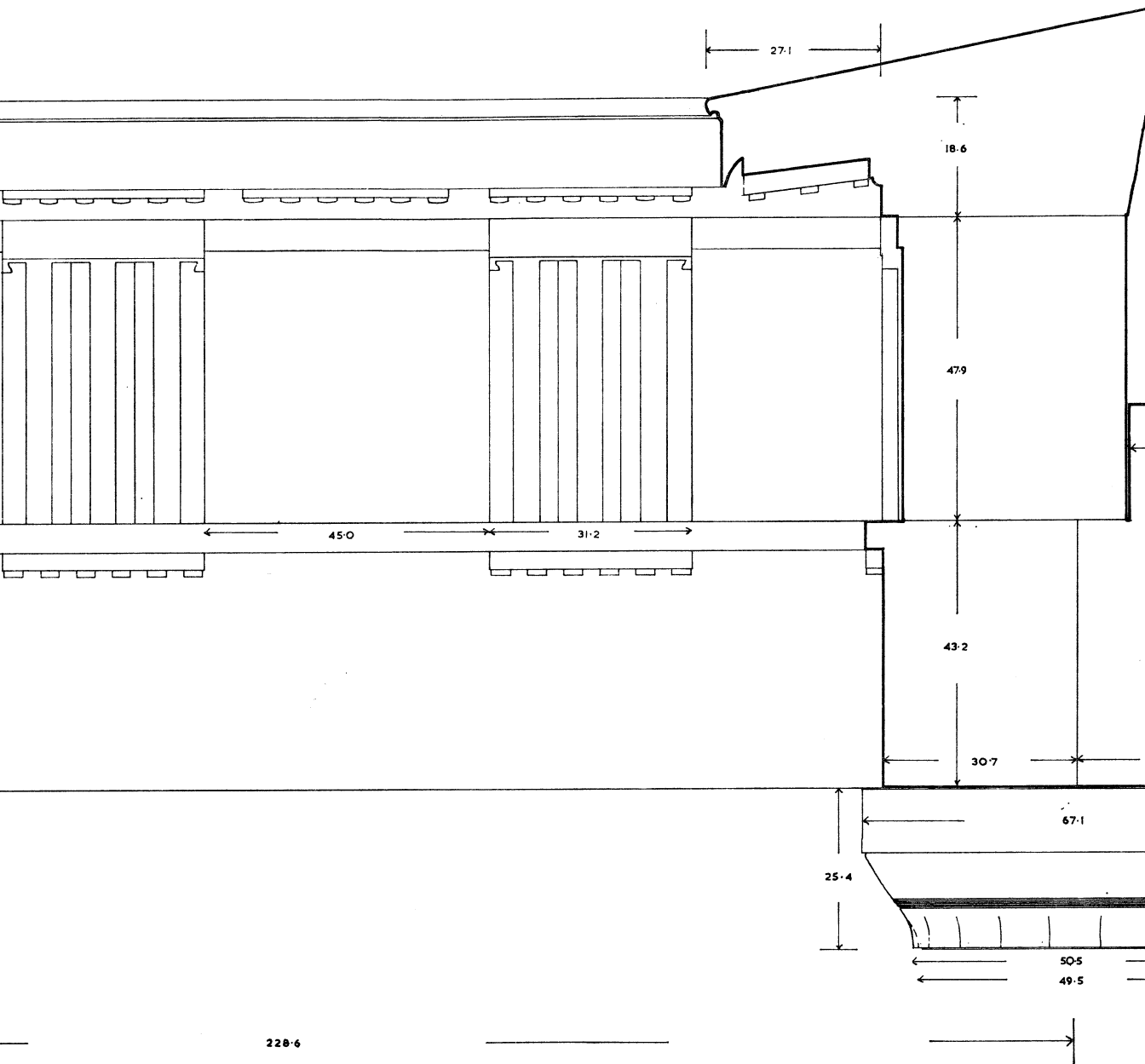

228-6

10 20 30 40 50 60 70 80 90 100 110 120 CM.

J.J.L.

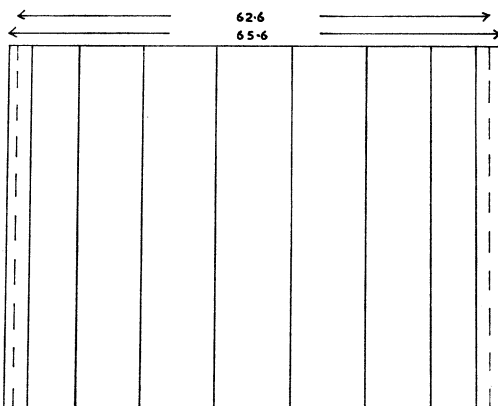
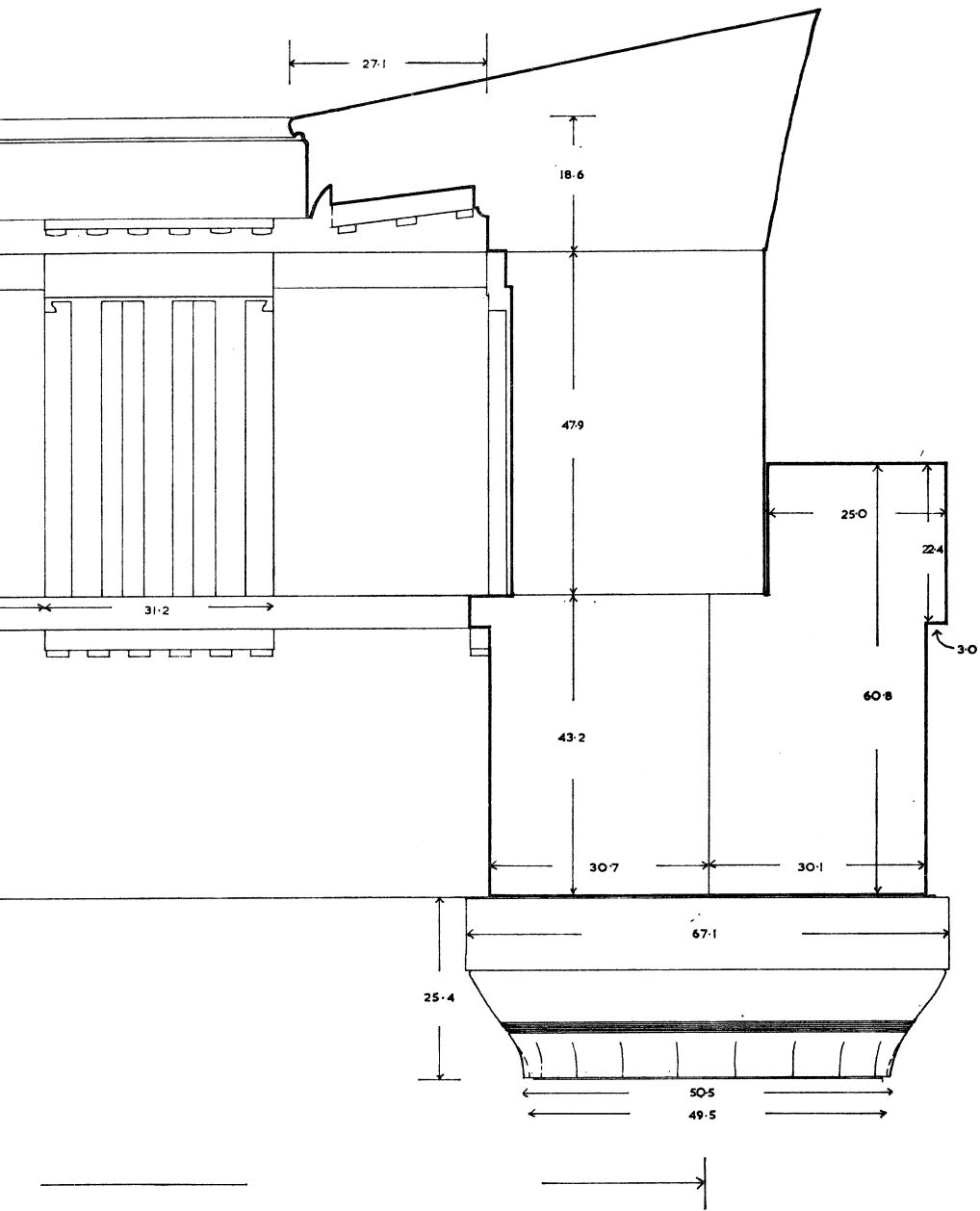

80 90 100 110 120 CM.

J.J.T.

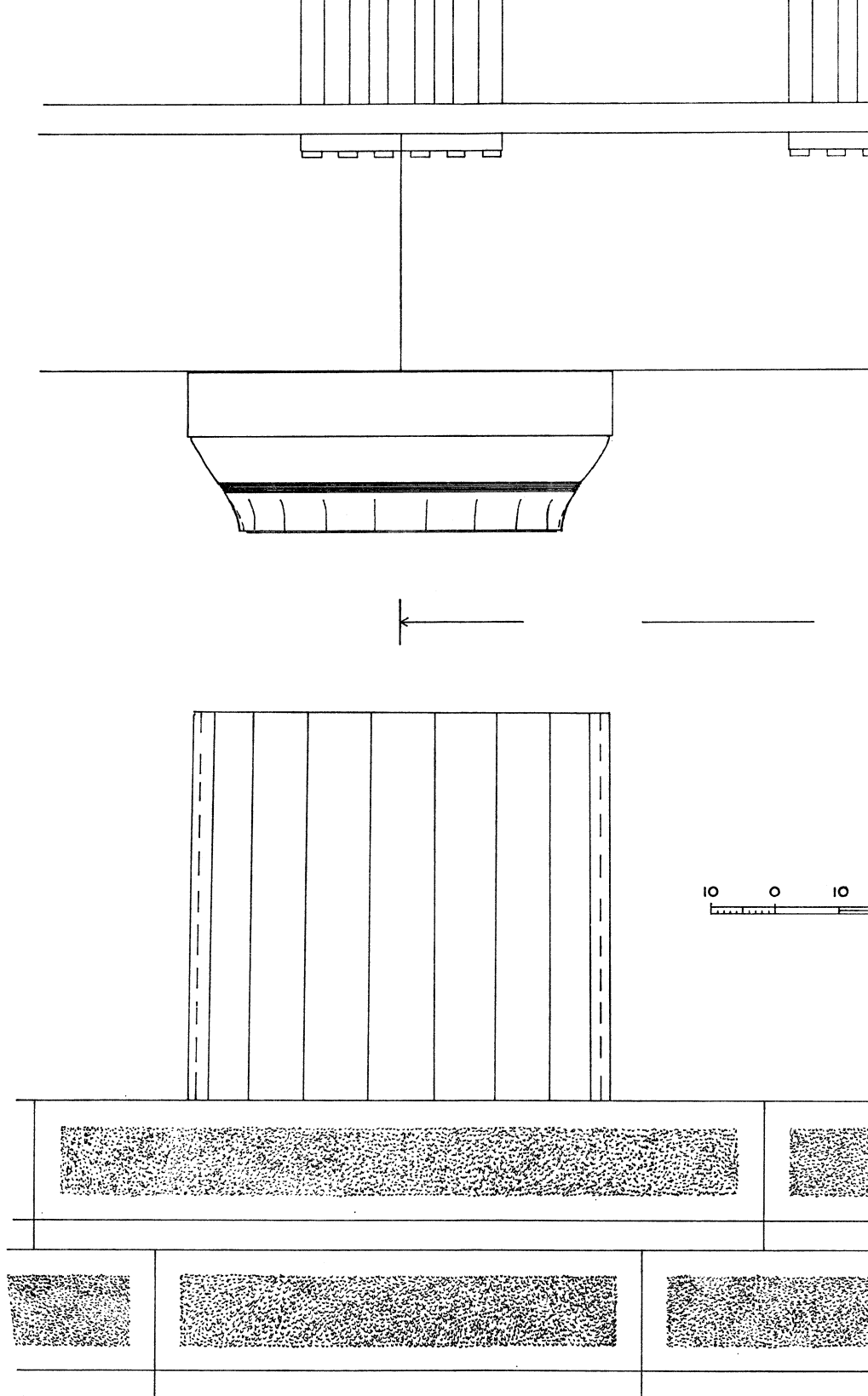

FIG.

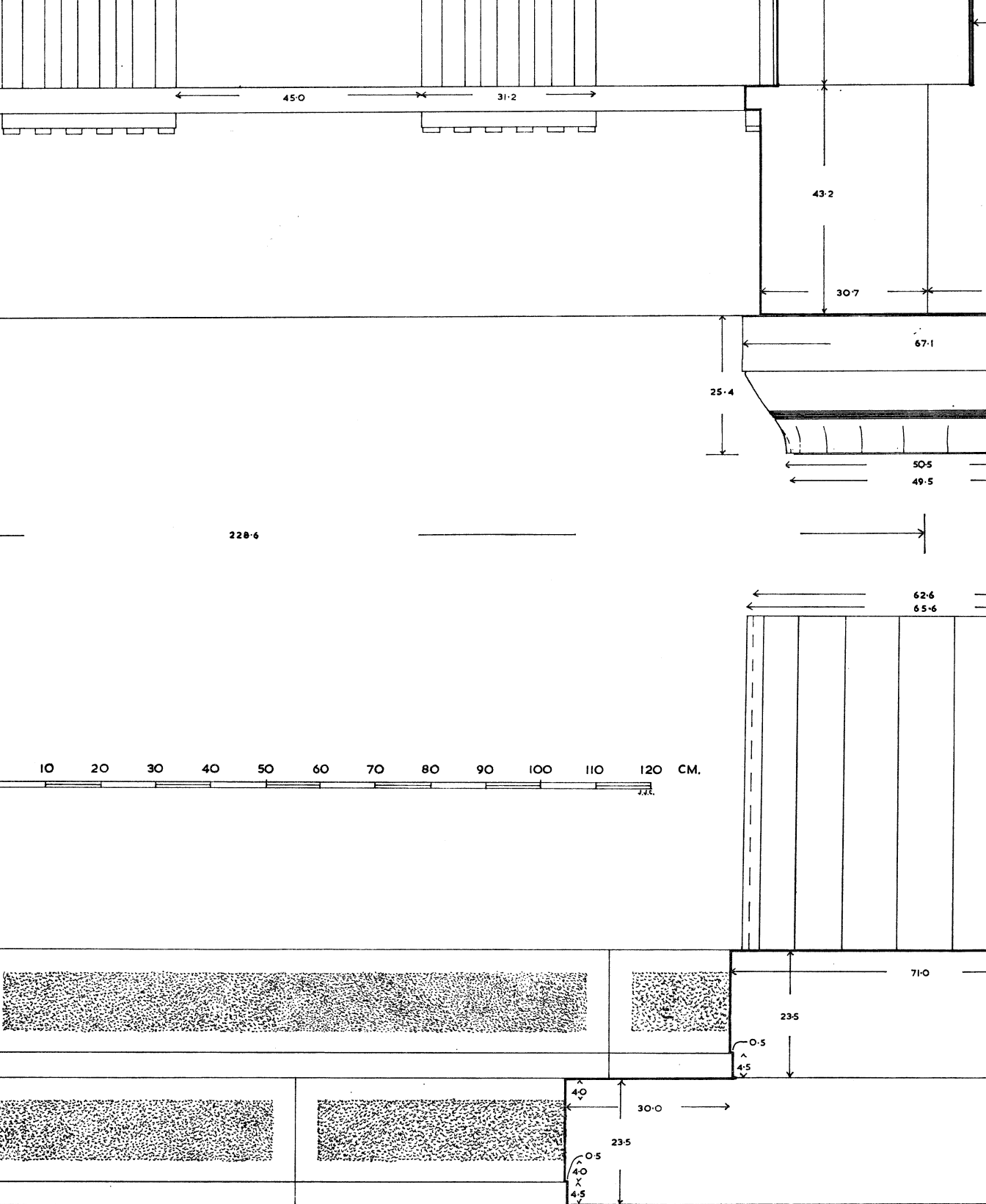
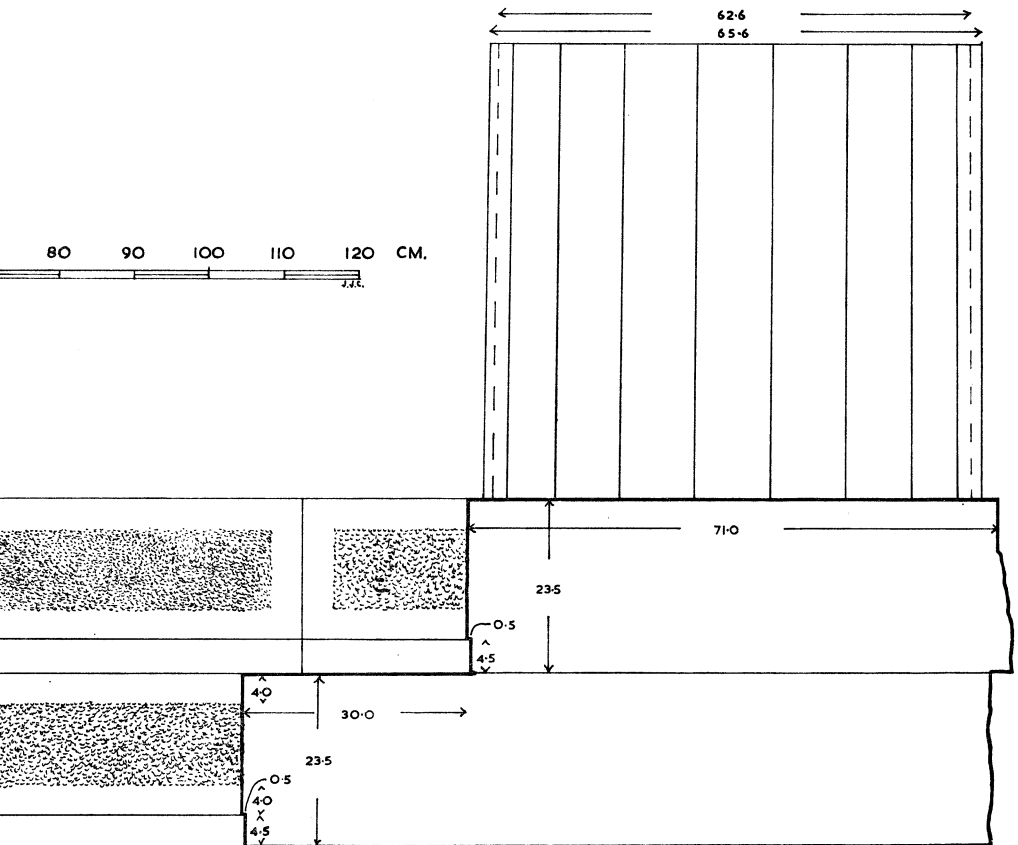
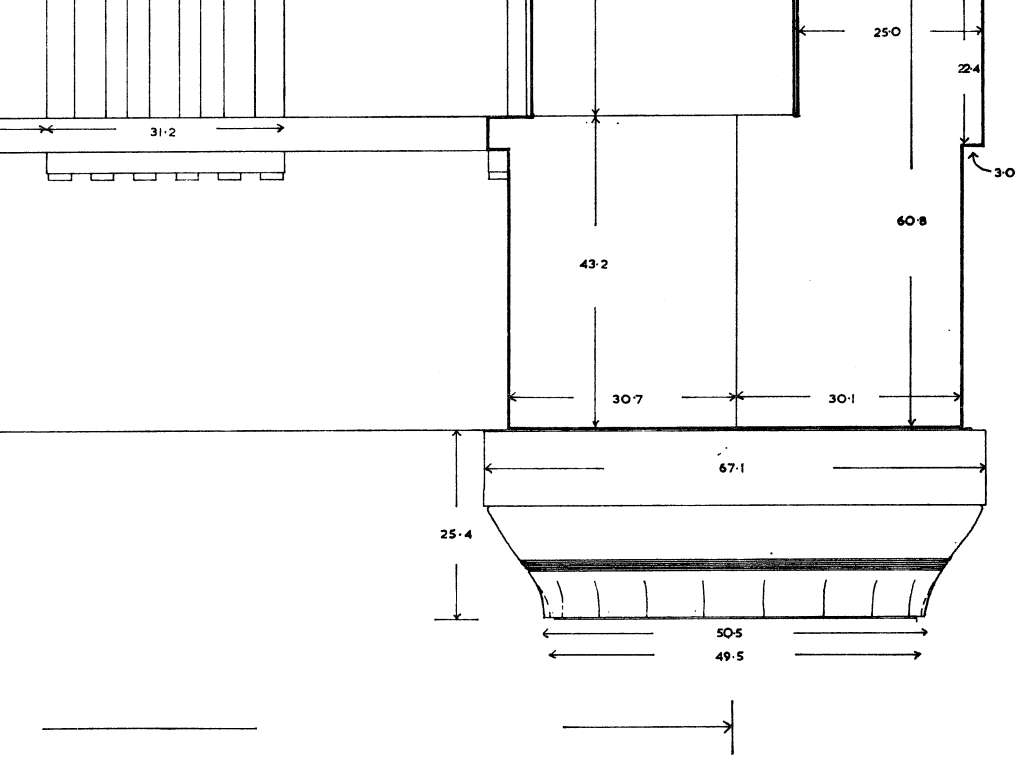

FIG. 7. THE DORIC ORDER RESTORED (SCALE 1 : 10)





10)

out of the question here ( $2 \times 2.286 = 4.572$ , not  $5.66$  m.); a less obvious one of five outer spans to two inner ones fits much more nearly ( $5 \times 2.286 = 11.43$ ;  $2 \times 5.66 = 11.32$ ),<sup>19</sup> but still does not have the necessary accuracy, and no other relationship is possible.<sup>20</sup>

The upper edge of the rear wall orthostates is clearly not straight (PLATE 45, *a*); in fact it forms a fairly regular swinging convex curve, with the centre 0.24 m. higher than the ends (FIG. 6A). With the entire stylobate and most of the step below missing, it is impossible to recover the true curve of the stylobate. However, since the upper surface of the top foundation course does form a convex curve, though a rather broken-backed one (FIG. 6C), it is virtually certain that the stylobate was curved, with the irregularities presumably made up in the lower step and stylobate courses. A similar curvature is found in the stylobates of the stoa at Brauron,<sup>21</sup> the South Stoa at Corinth,<sup>22</sup> and the North-west Stoa at Thasos.<sup>23</sup>

*The Doric Order* (FIG. 7). The column trace on one of the stylobate blocks is not sharp enough to be measured accurately, but its diameter is approximately 0.68 m. However it is set back 4 cm. from the front of the stylobate, and so 0.67 m. is the maximum diameter for the column if it is to get on the stylobate. Two surviving drums have no square dowel hole at the lower end, and so come from the bottom of a column.<sup>24</sup> One has a lower diameter of 0.626 m. in the flutes (*c.* 0.656 m. on the arrises) but the other has a lower diameter in the flutes of only 0.605 m. Absolute accuracy in the repetition of dimensions was apparently not considered necessary in a stoa, for the lower diameters of the columns of the stoas at Brauron and Perachora vary similarly.<sup>25</sup> There are fourteen drums lying on the site of the stoa (PLATE 46, *d*), and they have an average height of 1.095 m.<sup>26</sup> There is no tendency for the upper drums to be shorter than the lower drums. A column with four drums and a capital (*H.* = 0.25 m.) would therefore have a height of 4.63 m. or *c.* 6.9 m. lower diameters;<sup>27</sup> this is rather slender for the fourth century<sup>28</sup> but with only three drums and a capital, it would have a height of only 3.535 m. or *c.* 5.3 m. lower diameters which is sturdier than usual and would make the Ionic columns unpleasantly low (see pp. 165–7). The flutes in section form the arc of a circle (FIG. 10C).

The upper diameter of the columns as given by a surviving capital is 0.495 m. in the flutes, *c.* 0.505 m. on the arrises, giving a total diminution of 0.111 to 0.131 m. or *c.* 0.03 m. per drum. In fact the diminution of the surviving drums varies greatly and is rarely as much as 0.03 m.<sup>29</sup> But since we have less than a tenth of the original number of drums to work on and there are not many upper drums, and since the extent to which the upper and lower column diameters varied is not known, the way in which the taper was handled must remain uncertain.

<sup>19</sup> It is ironic that with Versace's figure of 5.71 m. this relationship could be made exact, while my figure of 5.66 m. suits the irregularity shown in his plan (pl. xii. 2).

<sup>20</sup> For further discussion of this feature of the plan, see pp. 179–80.

<sup>21</sup> Ch. Bouras, 'Η Ἀναστήλωσις τῆς Στοᾶς τῆς Βραυρωνῶνος 32–3.

<sup>22</sup> *Corinth* I. iv. 91–2.

<sup>23</sup> *Thasos, L'Agora* I. 17–19.

<sup>24</sup> Not noticed by Versace, 269.

<sup>25</sup> *BSA* lix (1964) 106. Drum no. 1 (*in situ*) has a lower diameter of 0.59 m. in the flutes but drum no. 2, with a lower diameter of 0.58 m. is also a bottom drum for its lower face, revealed only recently when the drum was knocked over, has no dowel hole. Ch. Bouras, *op. cit.*, 35.

<sup>26</sup> Varying from 0.89 to 1.21 m. but only six fall outside the group 1.05 to 1.15 m.

<sup>27</sup> This, as all subsequent proportions involving the lower column diameter, is based on a lower diameter of 0.626 m.

in the flutes. Versace 269, pl. xii assumes a lower diameter of 0.65 and a height of 3.90 m.

<sup>28</sup> I date the stoa to the mid fourth century B.C. (see below). The slenderest temple columns of the fourth century are those of the Temple of Zeus at Nemea, but those of the Tholoi at Delphi and Epidauros were taller (6.82 lower diameters, *BCH* lxiv–lxv (1940–1) 121–7; 6.92 lower diameters, Roux 140).

<sup>29</sup> Because of difficulties in measurement, my figures may sometimes have been a few millimetres out. But the variation in diminution, even between drums which appear to have occupied the same position in the column, is much more than this (minimum diminution: 0.006 m. in 1.095 m., maximum diminution: 0.035 m. in 1.17 m.). The stone used for the columns is a soft and easily damaged poros which was originally covered with stucco now largely lost, so that little weight can be put on the figures obtained for the diminution.

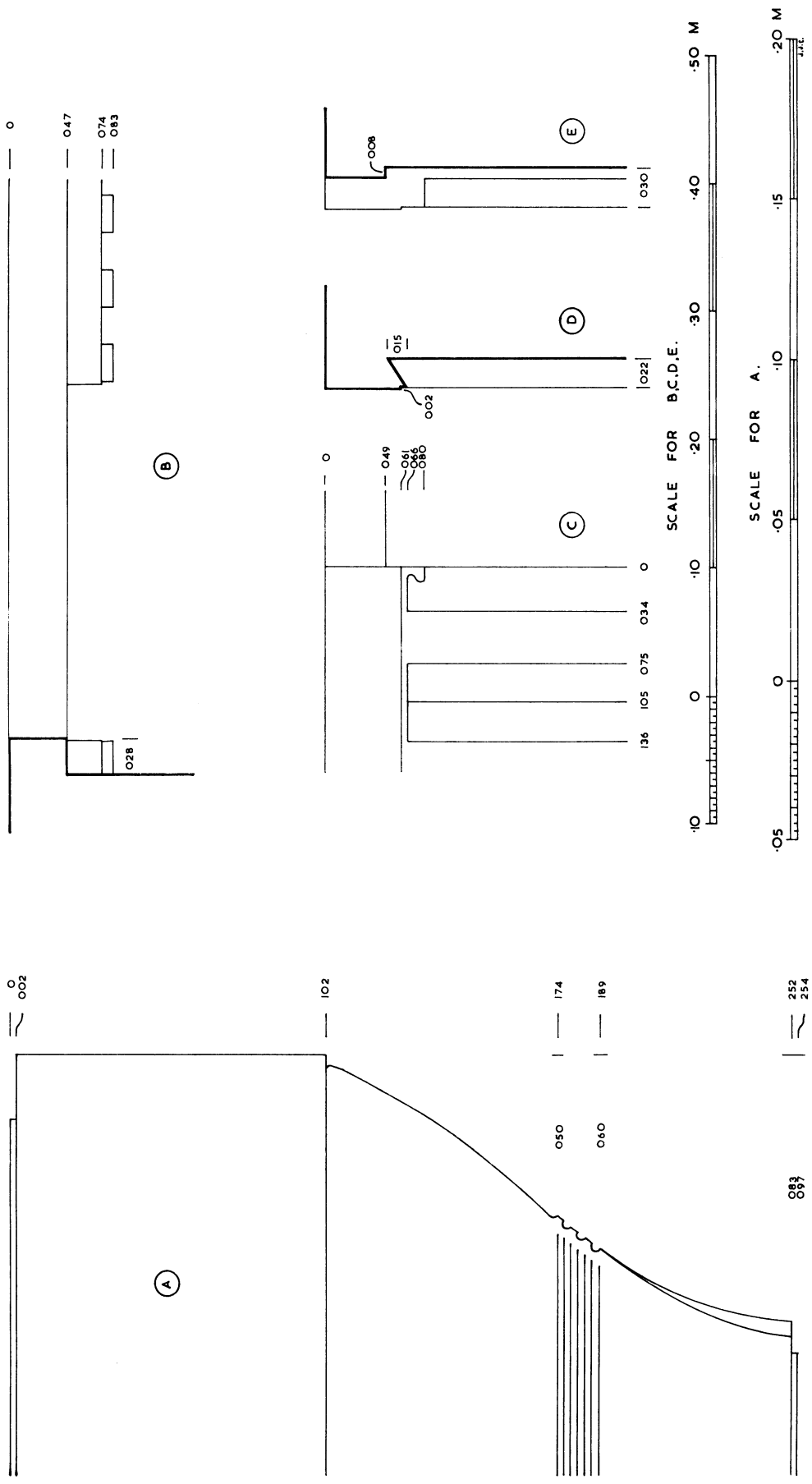

FIG. 8

A. Profile of the Doric capital (Scale 1 : 2)      B. Details of the Doric architecture (Scale 1 : 5)      C, D, E. details of the Doric frieze (Scale 1 : 5).

A well-preserved Doric capital (FIG. 8A, PLATE 47, *a*) belonging to these columns has the following main dimensions:<sup>30</sup> total height 0.254 m. (including relieving surfaces), lower diameter 0.49 m. in flutes, *c.* 0.505 m. on arrises, height of abacus 0.10 m., of echinus 0.07 m., of annulets 0.015 m., of neck 0.065 m., width of abacus 0.671 m., projection of echinus with annulets 0.06 m. The echinus has a slightly curved profile and the three annulets are separated by semicircular grooves rather than by the usual quarter circles. A square dowel, 0.085 × 0.085 m., connected the capital to the column, but there was no dowelling to the architrave. A relieving surface 0.002 m. high protected the top and bottom of the capital. The flutes of the column grow shallower towards the top of the shaft, and at the neck of the capital they fade gradually out just below the annulets.

The architrave is 0.432 m. high with a taenia 0.047 m. high and projecting 0.028 m. (FIG. 8*b*). The regulae are 0.027 m. high with six slightly tapered guttae 0.009 m. high below them. The thickness of the architrave (0.608 m.) is made up of two rows of blocks, the front ones being 0.307 m. deep and the backers 0.301 m. One of the backers, though broken in two, still preserves its original length of 2.30 m. Three *pi*-clamps tied the two beams of each span together, and *pi*-clamps also tied the beams of adjoining spans. The top of the architrave backer is stepped; for 0.085 m. from the front it is at the same level as that of the front beam, so as to take the frieze (only 0.38 m. deep), but behind this it rises to a height of 0.608 m. giving a ledge *c.* 0.25 m. wide for the roof woodwork. Its inner face consists of two fascias, the lower one 0.38 m. high, the upper one 0.225 m. high and projecting 0.03 m.

The frieze is 0.479 m. high, with metopes 0.45 to 0.46 m. wide and triglyphs 0.317 to 0.321 m. wide. The frieze consists normally<sup>31</sup> of alternate blocks with a triglyph between two metopes and a metope between two triglyphs (PLATES 47, *b*, *c*). The M-T-M blocks could be cantilevered over each column so that the architrave would only have to carry half the weight of the frieze. Where a triglyph occurs at the end of a block, it would overlap the adjoining metope by more than 1 cm., since otherwise the frieze elements are too wide for the intercolumniations. The metope taenia is 0.049 m. high, the triglyph taenia 0.061 m. (FIG. 8 C, D, E). The grooves of the triglyphs have horizontal tops and are considerably under-cut. The half-grooves have small curved ears at the top 0.014 m. long.<sup>32</sup>

The frieze originally bore a monumental inscription, presumably recording the circumstances of the building of the stoa. Five inscribed metopes survive, with one letter 0.18 to 0.21 m. high carved in the middle of each. The preserved letters are Π (trig.) O (PLATE 47, *c*), O (trig.) I (trig.), and N (trig.) blank.<sup>33</sup> A block with (broken) (trig.) . is also recorded.<sup>34</sup>

The letters are formed by a flat-bottomed groove 0.025 m. wide and 0.005 m. deep and probably originally contained bronze or gold inlays.<sup>35</sup>

The cornice is 0.186 m. high to the top of the crowning moulding, and projects 0.27 m. Above a fascia 0.048 m. high is a small soffit moulding with, unusually, an ovolo profile (FIG. 9 A, B; PLATE 47, *d*). The mutules, 0.319 to 0.32 m. wide, are separated by viae 0.065 m. wide. The soffit of the cornice is at an unusually shallow angle, 7¼° but its upper surface is steeper, 11½°. The crowning moulding is an ovolo-type hawksbeak with the corona receding below it.<sup>36</sup>

<sup>30</sup> Versace 268, gives capital height: 0.266 m., abacus height: 0.105 m., height of echinus, annulets, and neck: 0.16 m., abacus width: 0.675 m.

<sup>31</sup> One of the inscribed frieze blocks consists of two metopes and two triglyphs.

<sup>32</sup> The shape of the triglyph groove tops and of the small ears is wrongly shown by Versace, pl. xiv. 5.

<sup>33</sup> Leonardos (60) records only Π, O and N, Versace (26)

only Π O and O I. All five can now be seen in the Ampharaion Museum.

<sup>34</sup> *AE* 1925-6, 21-2. I owe this reference to the kindness of B. Chr. Petrakos.

<sup>35</sup> Cf. *AE* 1885, 154.

<sup>36</sup> My terms for describing mouldings are taken from Lucy Shoe. For the receding corona see L. Shoe 106, pl. lv. 1-7.

At the ends of the façade, where a plain wall replaced the Doric colonnade, it has been assumed that the entablature continued unaltered. The wall here was probably of stone throughout (this would explain its complete disappearance while the end and rear walls are still quite well preserved), and so could carry the entablature. The short ends of the stoa do not have the right length to take a frieze with the same frieze unit as that along the front, so probably the

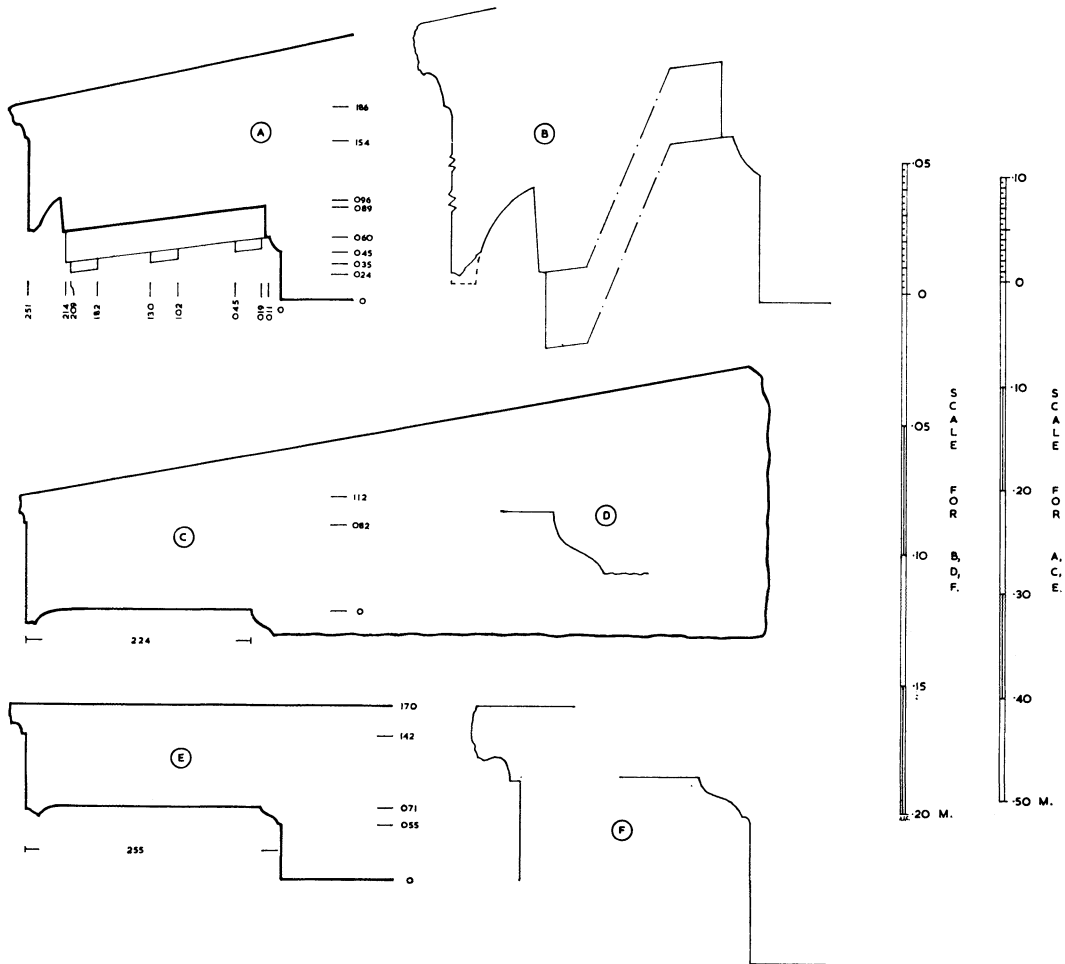

FIG. 9

- A. Section through the Doric cornice (Scale 1 : 7.5).      D. Its moulding (Scale 1 : 3).  
 B. Its mouldings (Scale 1 : 3).                                      E. Section through the end cornice (Scale 1 : 7.5).  
 C. Section through the rear cornice (Scale 1 : 7.5).              F. Its mouldings (Scale 1 : 3).

entablature returned along the end only for the width of a triglyph. The end and rear walls of the stoa above the orthostates, consisting either of mudbrick or of rubble (PLATE 46, *a*), would not be strong enough to carry a full stone entablature.

Versace restores a cornice without mutules to crown the end and rear walls. Several blocks of a cornice of this type (FIG. 9C-F, PLATE 49, *a, b*) are to be seen near the Museum at the Amphiraion. A small cyma reversa decorates the angle where the front of the cornice bed meets the soffit, and this suggests a connection with the temple, but the cornice projection is almost

the same as that of the Doric cornice of the stoa and so too small to suit the temple. Below the crowning hawkbeak, the corona recedes as it does on the Doric cornice.<sup>37</sup> One of the blocks preserved is a corner block with the lower angle of a pediment, in which the two horizontal cornices as well as the raking cornice have no mutules, and this block must come from the west corner of the south-west end of the stoa, showing that Versace was right in placing this cornice along both the back and sides of the stoa.<sup>38</sup> The same arrangement is found in Stoa J at Samothrace, and in the L-shaped Stoa on the Agora and other buildings at Delos;<sup>39</sup> the Treasury of the Megarians at Olympia, also has a similar cornice along the sides where the frieze is omitted.<sup>40</sup>

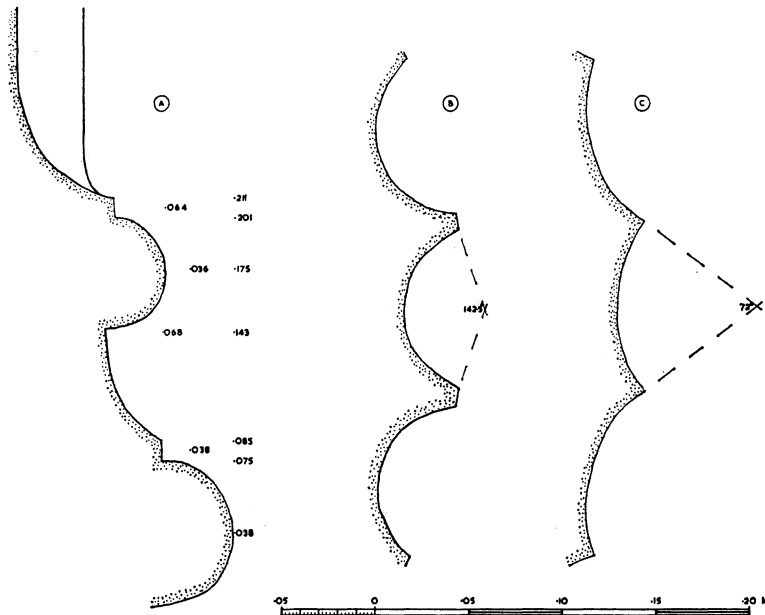

FIG. 10

- A. Section through base of Ionic anta.  
 B. Section through Ionic flute.  
 C. Section through Doric flute (All at scale 1 : 4).

*The Ionic Order.* There is no apparent difference between the Ionic bases of the central colonnade and those of the two partitions (FIG. 10A; PLATE 46, b). One base is still *in situ* in the north-east partition, and in the central colonnade the seventh base from the south-west was also found *in situ*. In both cases the lower part of the shaft is worked in the same block as the base, the total height being 0.45 to 0.50 m. The base itself consists of two tori with a cavetto between, instead of the more usual scotia. The height to the top of the upper torus is 0.205 m., the diameter of the lower torus is 0.80 m. and the lower diameter of the column (on the arrises) is 0.64 m.<sup>41</sup>

Some twenty drums of the Ionic columns are still to be found on the site. They average 1.012 m. in height, varying from 0.80 m. to 1.10 m.; the lower drums (*c.* 1.10 m.) are higher than the upper ones (*c.* 0.96 m.). The twenty flutes have a width about three times their depth and

<sup>37</sup> L. Shoe, pl. lv. 4-6.

<sup>38</sup> Compare the block from the north corner of the north-east end of the stoa, shown in Versace, pl. xiv. 4.

<sup>39</sup> A. Conze, A. Hauser, *Untersuchungen auf Samothrake* II. 50, pl. LV. iii; R. Vallois, *L'architecture hellénique et hellénis-*

*tique à Delos* ii. 213-15.

<sup>40</sup> *Olympia*, Plates I, pl. xxxvii.

<sup>41</sup> Versace 262, pl. xiv. 1 gives the lower diameter as 0.61 m. and since he omits the apophyge, the whole proportions of the Ionic base are wrongly shown.

are separated by narrow fillets (FIG. 10B). At the base they do not end with the usual quarter sphere but are cut off straight. They grow shallower further up the shaft and meet the capital too without a spherical ending.<sup>42</sup>

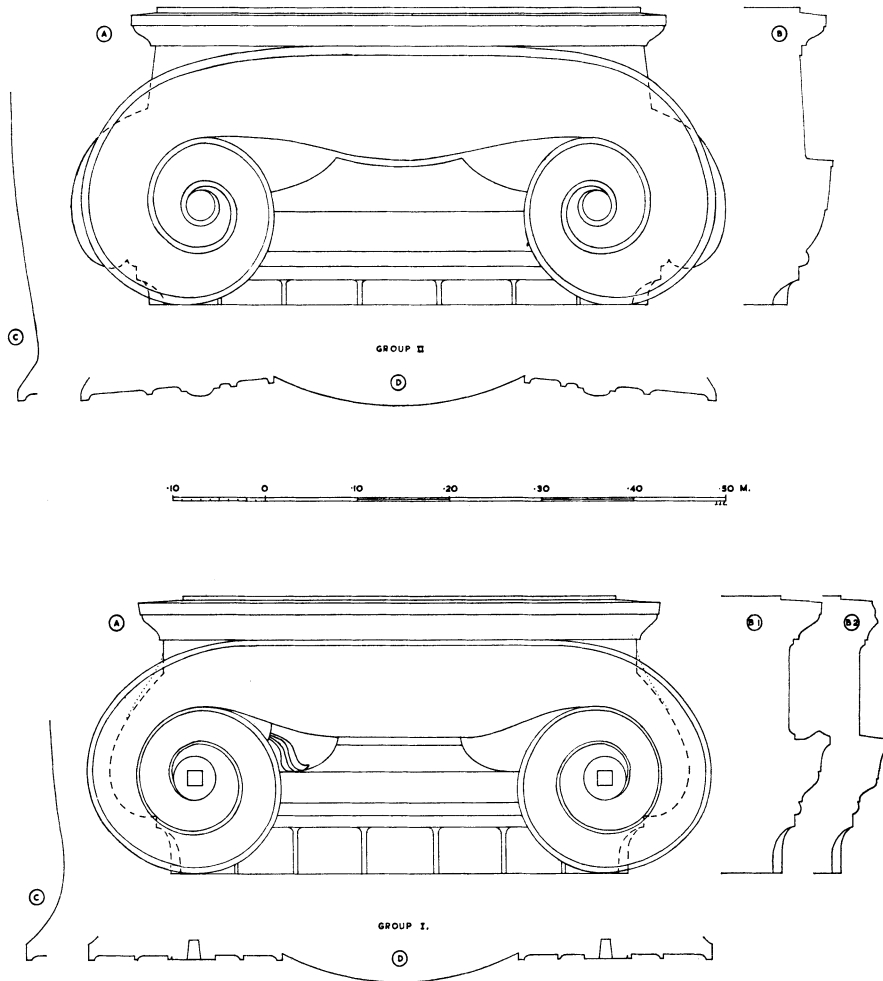

FIG. 11. IONIC CAPITALS; TYPE II ABOVE AND TYPE I BELOW (SCALE 1 : 8)

- |  |  |
|--|--|
| A. Volute face.                          | C. Half horizontal section through baluster end. |
| B. Vertical section through volute face. | D. Horizontal section through volute face.       |

There are thirteen Ionic capitals preserved in the museum and on the site of the stoa. They fall clearly into two groups, the chief difference being that the volutes of one group lie on the same plane (Group I) (FIG. 11, below; PLATES 48 *c, d, e*), while those of the other group are canted inwards so that the volute faces of these capitals are concave (Group II) (FIG. 11, above; PLATE 49, *a, b*). Of the first group, five capitals remain,<sup>43</sup> all in the Museum, and of the second group eight, five in the Stoa and three in the Museum.

<sup>42</sup> Contrast Versace, pl. xiv. 1.

<sup>43</sup> One of these is obviously a late copy. Its abacus is merely bevelled instead of being a *cyma reversa*; the eyes of the volutes are hemispherical, while on all the other

capitals of Group I they are flat with square holes to take an inset eye; and its workmanship is inferior. The following remarks about Group I do not apply to this capital.

The two groups differ not only in volute arrangement: Group I has a height of 0.29 m.<sup>44</sup> and a lower diameter of 0.465 to 0.475 m. (in flutes), Group II a height of 0.31 m. and a lower diameter of 0.49 to 0.498 m. The capitals of Group I have an echinus of cyma reversa profile with a concave cushion above, while Group II capitals have a simpler convex echinus with a straight cushion. Compare FIG. 11B, above and below.

Differences within these groups are minor and limited to the decoration. The angles between the volutes and the central part of the *canalis* are filled by a small fan-shaped palmette. On the capitals of both groups this palmette was originally painted, and on one capital of Group I traces of the painting can be seen in the thin coat of stucco. On another of the Group I capitals, however, the palmette was carved in relief (PLATE 48, c). On some of the capitals of Group I traces of painted decoration can also be seen on the echinus, but the exact form of it varies.

Can all these capitals be reasonably attributed to the stoa? There is no published record of their discovery, but Versace appears to think that they did all come from the stoa since he attributes capitals with a palmette ornament to the columns of the end partitions.<sup>45</sup> One might argue that the difference in the capital form was the result of this difference in position, and attribute all the Group I capitals to the columns of the end partitions. However, only four Group I capitals would be necessary with this arrangement, and it is unlikely that all four should have survived; further they all survive in such good condition that there would be no need for the fifth to be made as a replacement.

The only other possibility if we wish to keep all the thirteen capitals in the stoa is to assume a change of workmen while the stoa was under construction. Oropos changed hands several times in the fourth century, and one might assume that the stoa was begun by Thebans and finished by Athenians, or vice versa. It is true that the Group II capitals have a typically Peloponnesian volute arrangement and the Group I capitals the Attic one. But when we look at the echinus of the two groups, it is Group I which is typically Peloponnesian and Group II closer to Attic. Whatever one's attribution of the two groups, it is hard to believe that the Athenians would at this date consciously work in the Peloponnesian style—or that, if they did, they would be such bad copyists as these capitals show them to be!

One group of capitals must therefore be found another home. Since five of the Group II capitals are still lying in the stoa, this group must be the one that belongs to the stoa. Group I may come from the Temple of Amphiaraos, where there were ten Ionic columns to support the roof across the cella. The surviving drums of these columns are unfluted. However, one of them was reduced to a cylinder from being previously fluted, and unless it originally came from the stoa, it shows that the internal columns of the Temple used to be fluted.<sup>46</sup> The other drums are of poor workmanship and are obviously late replacements. The fact that this colonnade needed late repair supports my attribution since one of the Group I capitals is also a late replacement.

The height of the Ionic columns depends on the construction of the roof, and will be discussed below.

The antae which form the outer ends of the two end partitions have a width equal to the lower diameter of the Ionic columns, and the base mouldings of anta and column are the same (FIG. 10A). No fragments survive of the shafts of the antae and considerable difficulties stand in

<sup>44</sup> Versace 262 gives the height as 88 cm., presumably a misprint for 28 cm.

<sup>45</sup> p. 262. He does not otherwise differentiate the two groups.

<sup>46</sup> There is no known instance of unfluted columns in the

cella of a temple of the fourth century or earlier. The unfluted Doric columns inside the Metroon at Olympia are late reworkings of originally fluted columns, and in any case they may belong rather to the Echo Stoa (*Olympia*, Text II, 38, fig. 16).



the way of Versace's attribution of a well-preserved sofa capital to the antae.<sup>47</sup> It consists of a block 0·348 m. high, 0·47 m. thick, and 0·72 m. wide (FIG. 12, PLATE 48, *c*). The back and sides, almost unworked, were obviously not meant to be seen, and only the front is carved. The neck width of this capital is 0·49 m., almost exactly the same as that of the Ionic columns, and so it seems to suit the antae admirably. But while the front of the capital projects only 0·035 m.<sup>48</sup> from the background surface (which appears to be meant to be flush with some wall face), the front face of the lower part of the anta projects 0·33 m. from the wall face; yet the anta could not taper from 0·33 m. deep to 0·035 m. in a height of 5·235 m. Further, the depth of the block, 0·47 m., is more than that of the lower part of the anta, so that the capital must have projected into the wall, although the lower part of the anta is butted against it; and this projection is not enough to have any structural value.

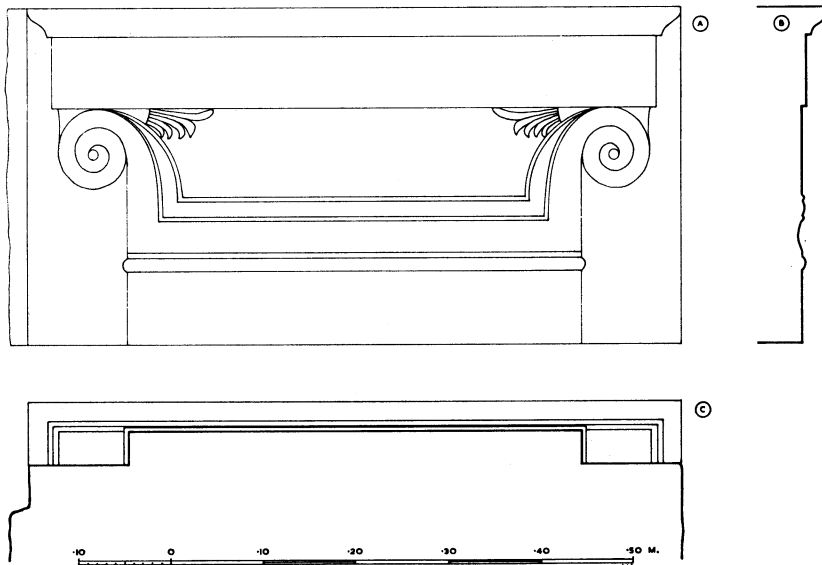

FIG. 12. IONIC ANTA CAPITAL(?)  
 A. Elevation.                      B. Vertical section.  
 C. Horizontal section looking up (Scale 1 : 8).

These observations raise doubts about the correctness of attributing this capital to the stoa, but it is difficult to suggest any other place for it; for there is no sign of Ionic antae inside the Temple of Amphiaraos. Most capitals of this type appear to have crowned stelai or carried votive offerings, but they all have the ends carved even if not finished so finely as the front. The capital at Oropos is unique in having no side view at all. This raises the possibility that it was not finished and that the field was going to be worked back further; but against this is the fact that the field is quite smoothly finished. It is unlikely that a capital would have been put in position in the building in such a state, and yet it is difficult to see how it could have survived otherwise through the period when the sanctuary was in use. In the present state of knowledge there is at least no stylistic objection to attributing this capital to the stoa, and though the difficulties remain, it seems most reasonable to do so.

<sup>47</sup> Versace 262; in his pl. xiv. 2, the volutes are drawn too big and the crowning moulding is shown as a straight bevel instead of a cyma reversa.

<sup>48</sup> Versace does not mention these peculiarities or the resultant problems.

*The Roof.* The major problem in constructing the roof of the stoa must have arisen over the partitions which separate off the end rooms, for here there is no direct support for the ridge of the roof. It was presumably because of this weakness that the end columns of the central colonnade were placed so close to the partitions. No cuttings are to be seen in the cornice or frieze blocks,<sup>49</sup> so that the only fixed points in restoring the roof construction are the pitch of the roof, the placing of the columns and the continuous ledge formed by the rear part of the architrave backers. This ledge was at a height of *c.* 5.235 m. above the stylobate, if, as is assumed in the following discussion, the Doric columns had a height of 4.63 m. If they had only three drums and a height of 3.535 m., the Ionic columns would in all cases be 1.095 m. (1.71 lower diameters) shorter than the figures given below.

Versace restores<sup>50</sup> a roof with horizontal cross-beams running across the stoa both over the partitions and over each of the columns of the central colonnade. A prop from each of these crossbeams supports a pair of rafters, but there is no indication of how the roof was carried over the space between two columns. But even disregarding the upper parts of the roof, this system has two disadvantages. The Ionic columns are very squat, with a height of only 4.50 m. (seven lower diameters); and the central colonnade carries no beam running along the length of the stoa although Ionic capitals are clearly meant to be seen carrying a beam parallel to their volute face.

The first disadvantage can to some extent be remedied (FIG. 13A), for with a height of 4.63 m. for the Doric columns, the Ionic columns would have a height of 5.235 m. (8.16 lower diameters), which could be increased to about 5.37 m. (8.4 lower diameters) if there were a wall-plate (A) between the architrave backers and the cross-beams (B). A main longitudinal beam for the central colonnade could hardly run below these main cross-beams, since that would reduce the height of the Ionic order back to *c.* 4.95 m. (7.75 lower diameters). It would also lead to considerable problems where the longitudinal beam met the cross-beam (G) carried by the columns of the partition. The longitudinal beam (C) would therefore have to be at the same level as the cross-beams (B), so that four main beams would meet on top of each Ionic capital, as apparently happened also in the Stoa of Philip at Megalopolis.<sup>51</sup> A ridge beam (D) would be carried by props above the central colonnade and the rafters (E) would be supported on the ridge beam and at the eaves, and probably by an intermediate purlin (F) as well. Over each end room the same system would continue, the ridge beam (D) being supported by the end wall, and by a prop from the cross-beam (G) across the partition. Since its support would thus be less direct than usual, the ridge beam could here be assisted by purlins of increased size (H), since they would be better supported than usual.

The two chief disadvantages of such a roof are the still rather low Ionic columns and the considerable structural weakness of having four main beams resting on the top of an Ionic capital with a bearing surface only 0.56 × 0.52 m. in size. Both disadvantages can be avoided if the main cross-beams were not horizontal, but sloped at the same angle as the roof (FIG. 13B). Roofs of this type were used in the Stoa of Antigonos at Delos,<sup>52</sup> the Stoa of Orophernes at Priene,<sup>53</sup> and the stoas round the Agora at Magnesia on the Maiander.<sup>54</sup> They perhaps had an earlier history in the Stoa Basileios at Athens.<sup>55</sup> With this system, the roof construction over the main portico of the Oropos stoa would be quite straightforward. Ionic columns about 5.67 m. (8.85 lower diameters) high would carry a wooden architrave (A) running along the length

<sup>49</sup> The actual dimensions given below to roof timbers are therefore all hypothetical, and so are not discussed in detail.

<sup>50</sup> Versace, pl. xiii. He does not discuss the problems in his text.

<sup>51</sup> *Megalopolis* 64–5.

<sup>52</sup> *Délos* v. 35–6.

<sup>53</sup> *Jdl* xxxi (1916) 306–9.

<sup>54</sup> C. Humann, *Magnesia am Maeander* 133–4.

<sup>55</sup> *Hesperia* vi (1937) 36.

of the building. The ends of the sloping cross-beams (B) would be supported on this and on the entablature or rear wall, and the actual rafters (C) would rest on purlins (D) carried by the cross-beams (B).

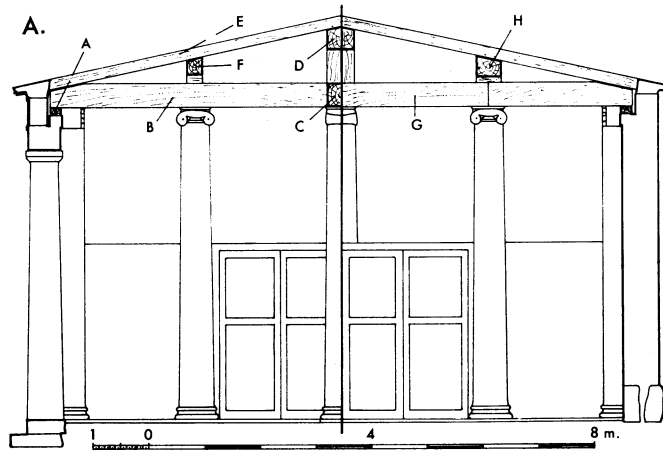

FIG. 13A. CROSS-SECTION THROUGH STOA SHOWING ROOF WITH HORIZONTAL CROSS-BEAMS

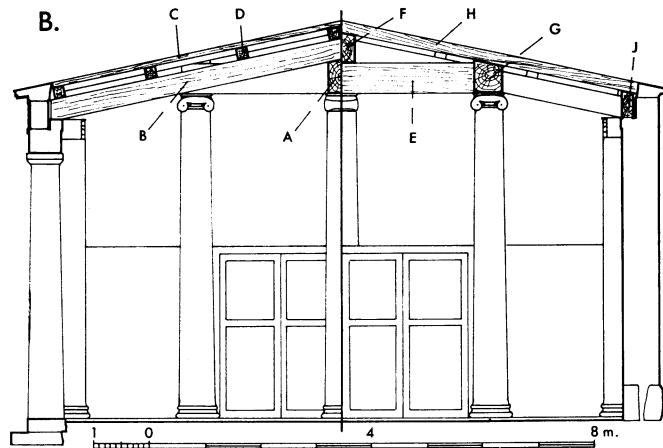

FIG. 13B. CROSS-SECTION THROUGH STOA SHOWING ROOF WITH SLOPING CROSS-BEAMS

If the columns of the partitions had the same height as those of the central colonnade, the cross-beams (E) which they carried would be at the same level as the wooden inner architrave (A), and so could not support it. The roof over each end room would therefore have to be quite different. A ridge beam (F) could be carried by the cross-beam (E) to the end wall; another heavy beam (G) could run from each partition column to the end wall, and rafters (H) rather stouter than those of the main portico roof could be carried on beams F, G, and a wall-plate (J). Such a roof is not unreasonable structurally, but it has the great aesthetic difficulty that the horizontal beam above each partition can run only above the columns, so that the antae of the partitions carry nothing, and must be *c.* 0.45 m. lower than the columns to which they answer.

So far it has been taken for granted that the columns of the partitions were of the same height

as those of the central colonnade; this is a natural assumption, since both sets of columns have the same type of base, the same lower diameter, and, as far as is known, the same type of capital. However, such an assumption means that the longitudinal beam carried by the central colonnade can never be supported by the cross-beam above the partition, but must simply butt against it. The advantage of having the last column of the central colonnade so close to the partition is thus largely lost.

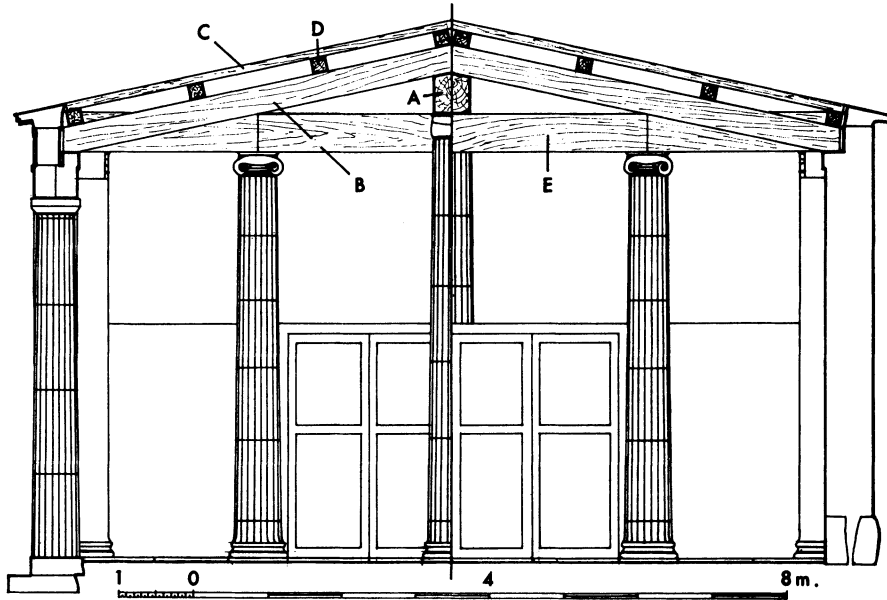

FIG. 14.

CROSS-SECTION THROUGH STOA SHOWING ROOF SUPPORTED ON IONIC COLUMNS OF TWO DIFFERENT HEIGHTS (SCALE 1 : 100)

In fact the least objectionable restoration of an inevitably rather awkward roof entails columns for the partitions *c.* 0.50 m. lower than those of the central colonnade. Such an arrangement may at first seem unacceptable, but parallels can be cited. The Doric columns of the east porch of the Propylaea at Athens have the same lower diameter as those of the west, but are 0.2795 m. lower.<sup>56</sup> Three Ionic columns found in the Late Roman Fortification Wall in the Agora at Athens belong probably to two pairs which differ in height by 0.80 m., although their lower diameters differ only by 0.03 m.<sup>57</sup> The stylobate of the South Stoa at the Argive Heraion is exactly the same width as the inner column bases, so that the diameters of the two sets of Doric columns are likely to have been the same even though their heights must have differed by at least 1.0 m.<sup>58</sup>

If this arrangement is accepted, the roof of the Oropos stoa can combine the best of the two systems discussed above (FIG. 14). The partition columns will be of the same height as the top of the architrave backers and the Ionic antae, (5.235 m. or 8.15 lower diameters) so that a horizontal beam (E) can run right across above each partition from anta to anta. Over the main portico the roof will consist of the same beams A to D as in the previous system, but the wooden

<sup>56</sup> W. B. Dinsmoor, *The Architecture of Ancient Greece*, ed. 2 339.

<sup>57</sup> *Hesperia* xxix (1960) 351-4. The two column heights

are equivalent to 7.12 and 7.81 times their respective lower diameters.

<sup>58</sup> Cf. C. Waldstein, *The Argive Heraeum* i, pl. xxii.

architrave (A) can now be supported by the cross-beam (E) and continue across each end room to the end wall. The sloping cross-beams (B), the purlins (D), and the rafters (C) can therefore be used in exactly the same way over each end room. Such a roof structure would be simple and effective and it would avoid both the structural and the aesthetic difficulties of the two other systems.

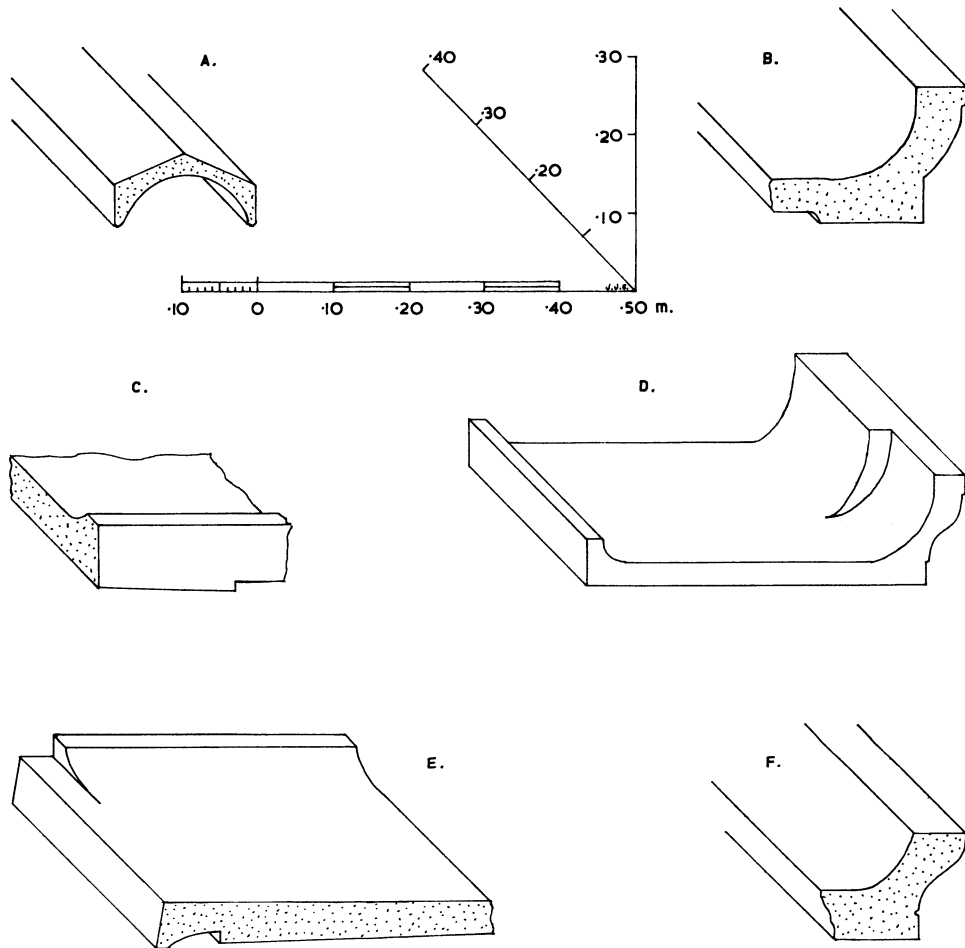

FIG. 15. TILE FRAGMENTS POSSIBLY FROM THE STOA (SCALE 1 : 10)

- |  |   |
|--|---|
| A. Ridge tile now in front of stoa.              | D. Sima fragment now in the museum depot.     |
| B. Sima fragment now in the museum depot.        | E. Pantile fragment now in the museum depot.  |
| C. Pantile fragment now in the wall of the stoa. | F. Sima fragment now in the wall of the stoa. |

Since both the sloping cross-beams (B) and the horizontal cross-beams (E) rest on the architrave backers, and since the slope of the roof and the width of the stoa are known, the height available for beams A and E together can be calculated, *c.* 1.02 m. This should probably be shared equally between the two beams, which means that the Ionic columns of the central colonnade had a height of  $5.235 + 0.51 = 5.745$  m. (8.96 lower diameters). The total height available for the sloping cross-beams (B), the rafters (C), and the purlins (D) is equal to the distance between the top of the architrave backers and the top of the Doric cornice, *c.* 0.65 m. This allows space for cross-beams 0.35 m. high, purlins 0.20 m. high and rafters 0.10 m. high.

The spacing of the cross-beams is uncertain, since both ends rested on continuous surfaces, but it is likely that there was one cross-beam over each column of the central colonnade. If two further cross-beams were placed between these, centred 1·89 m. apart, then four cross-beams could be set at nearly the same spacing (1·84 m.) between the end wall and the last column of the central colonnade. Such a spacing would neatly avoid an awkward encounter between the sloping cross-beams (B) and the horizontal cross-beams (E). The Greeks seem to have preferred an approximately square section for their main beams at least,<sup>59</sup> so that beam-widths roughly equal to the heights suggested above should probably be restored.

Large quantities of roof tile fragments are lying in the field in front of the stoa and there are more in the museum courtyard. They are all of coarse red clay, and since tiles of the fifth and fourth centuries were normally of yellow to buff clay,<sup>60</sup> not red, these may not be the original tiles. *Prima facie* they could come from one of the major repairs which the stoa underwent. The surviving tiles are of various different sizes and types (as shown in FIG. 15), and it is not possible to attribute any with certainty to the original construction of the stoa. Fragments of several different types of *sima* are also to be seen near the stoa and behind the museum. The one Versace uses in his restoration has a profile consisting of an ovolo between two fascias (cf. FIG. 15B).<sup>61</sup> The ovolo type of *sima* was mainly used in Periclean Athens though later examples in terracotta are not unusual, which makes it likely that this is the original *sima*, not a later replacement. Now the *sima* fragments also are of red clay; consequently the surviving tile fragments may include material from the original roof.

*The Bench.* Along the walls of the stoa ran a marble bench.<sup>62</sup> Almost all the base slabs for this, and many of the supporting brackets are still in position. The bench ran all round the two end rooms, leaving only a gap for the door, but in the main hall it ran only along the rear wall and did not return along the partitions. Many of the brackets for the bench have a stylized animal leg carved in very low relief on each side, while others are left plain. The latter might be later replacements, but it is difficult to see why so many replacements should be necessary, and it is more likely that the decoration was in fact never finished.

In the north-east end room, a pair of blocks are sunk near the north corner so that their tops are flush with the floor. These blocks, *c.* 0·40 to 0·45 × 0·90 m., are 0·68 m. apart, and on the top of each are two dowel holes *c.* 0·40 m. apart (FIG. 3). A similar pair of blocks was sunk near the east corner of the room. From their relation to the bench, it appears that these blocks were to take the supports for stone tables placed for the benefit of people using the bench. The two tables would not be enough to serve the whole room, but there are no traces of others, nor are there any such remains in the south-west room.

## PART II: STYLE AND DATE

*The Krepis.* A groove along the base of the risers of the *krepis* was not an unusual feature on a Greek building. The shadow so produced helped to show up the division between tread and riser, and so emphasized the articulation of the *krepis*. The simple groove cut in the step and stylobate of the Oropos stoa (FIG. 7) can be paralleled in buildings from the Temple of Hera at Akragas,<sup>63</sup> and the Temple of Poseidon at Sounion,<sup>64</sup> to the Little Stoa by the Artemision at Delos.

<sup>59</sup> A. T. Hodge, *The Woodwork of Greek Roofs* 92–3.

<sup>60</sup> e.g. those from the Tholos and the Stoa Basileios, Athens (*Hesperia* Supp. iv. 65, *Hesperia* vi (1937) 36–7), and those from the Dema House (*BSA* lvii (1962) 84).

<sup>61</sup> Shown in Shoe, pl. xix. 12, and discussed briefly *ibid.* 36.

<sup>62</sup> Versace 264–6 gives a satisfactory description of the bench.

<sup>63</sup> R. Koldewey, O. Puchstein, *Die Griechischen Tempel in Unteritalien und Sicilien*, fig. 148.

<sup>64</sup> *BSA* xlv (1950) 81.

Though a few buildings in Attica have grooved risers,<sup>65</sup> it is noticeable that the groove was normally omitted in Attic buildings of the fifth and fourth centuries. The Hephaisteion, the Parthenon, the Propylaea, the Erechtheion in Athens, and the temples of Nemesis and Themis at Rhamnous and of Demeter at Thorikos were all designed to have quite plain risers and they were followed in the fourth century by the East Stoa of the Asklepieion at Athens,<sup>66</sup> the temple of Amphiaraos at Oropos,<sup>67</sup> and the Choregic Monument of Thrasyllus at Athens.<sup>68</sup> The risers were also plain in the Doric architecture of Asia Minor,<sup>69</sup> where there was no tradition of a groove.



FIG. 16.

DIFFERENT FORMS  
OF ANNULET

In the Peloponnese<sup>70</sup> in the fourth century, it was the custom to use a more complex step treatment, of which the two stoas at Olympia provide good examples. In these the main part of the risers has a flat margin running round the raised central part of each block, and below this a double groove runs along the whole building, so that in effect a triple groove underlines each riser. This is not a standard scheme; various combinations of raised panels and double or triple grooves were used; but it is rare to find in Peloponnesian architecture just a single groove like that of the Oropos stoa.<sup>71</sup> It is, however, found in the Stoa at Perachora, the Tholos at Delphi<sup>72</sup> (lower two steps only), and in the Treasury of Cyrene at Delphi.<sup>73</sup>

Thus the krepis of the Oropos stoa does not belong to the full tradition of either Attic-Ionian or Peloponnesian architecture.

*The Doric Order.* The Doric capital preserves a good profile for chronological study. The echinus is still slightly curved; in the second half of the fourth century it became a simple truncated cone (e.g. the Tholos at Epidauros).<sup>74</sup> More important is the way in which the echinus meets the abacus with a pleasant curve. In later buildings, whether the echinus is straight or slightly curved, it is separated from the abacus by a sharp groove (e.g. the Tholos at Epidauros, the Temple of Zeus at Nemea,<sup>75</sup> the Temple of Zeus at Stratos,<sup>76</sup> the Stoa at Samothrace).<sup>77</sup>

The annulets of the stoa capital do not have the form normal in the fifth and fourth centuries (FIG. 16A), but are rather separated by semicircular grooves (FIG. 16B), a form which is very unusual, though a similar profile was used for the capitals of the pronaos of the Temple at Thorikos.<sup>78</sup> Later, after about 300 B.C., we find capitals with the annulets much broader and separated by a simple groove (FIG. 16C) (Stoa at Samothrace,<sup>79</sup> Stoa of Cotys at Epidauros,<sup>80</sup> etc.) but the carving of the Oropos annulets is

<sup>65</sup> The Temple of Poseidon at Sounion, the Nike Temple in Athens, the Stoa at Brauron (Ch. Bouras, 'Η ἀναστήλωσις τῆς Στοᾶς τῆς Βραυρωνῶνος 28), the West Stoa of the Asklepieion at Athens (*BCH* lxiix (1949) 345, fig. 13) and the Portico of Philo at Eleusis. In all these cases there is just a single groove.

<sup>66</sup> *BCH* lxiix (1949) 327, fig. 7.

<sup>67</sup> Versace, pl. xi.

<sup>68</sup> *AA* liii (1938), col. 39, fig. 4.

<sup>69</sup> Except Temple A in Kos (R. Herzog, *Kos* i, pl. 3, 4).

<sup>70</sup> I use the word Peloponnesian to describe the distinctive school of architecture discussed by G. Roux in *L'Architecture de l'Argolide aux iv et iii siècles av. J-C.* Besides the Peloponnese, this school includes Delphi, Aetolia, and Acarnania. Roux contrasts this mainly with Attic and Ionian architecture, but that of Macedonia should perhaps

also be distinguished. In the body of the present discussion the architecture of Oropos is not presumed to belong to any of these schools.

<sup>71</sup> It is true that the risers at Oropos have stippled panels surrounded by a smooth margin, but both panel and margin are in the same plane so that the effect is much less emphatic than that normal in the Peloponnese.

<sup>72</sup> *F. de D., Le Sanctuaire d'Athéna Pronaia* ii, pl. iii.

<sup>73</sup> *F. de D., Le Trésor de Cyrène*, pl. viii, ix.

<sup>74</sup> Roux 92, fig. 16.

<sup>75</sup> A. Blouet, *Expédition scientifique de Morée* iii, pl. 74.

<sup>76</sup> F. Courby, C. Picard, *Recherches archéologiques à Stratos d'Acarnanie*, 28, fig. 11.

<sup>77</sup> *BCH* lxxxvi (1962) 297, fig. 25.

<sup>78</sup> *Unedited Antiquities of Attica*, chap. ix, pl. 3.

<sup>79</sup> *BCH* lxxxvi (1962) 297.

<sup>80</sup> Roux 293, fig. 89.

much more delicate. A different scheme where the annulets are separated by rectangular grooves is sometimes found (e.g. the Tholos at Epidauros, the Portico of Philo at Eleusis,<sup>81</sup> and possibly the Palace at Vergina<sup>82</sup> (FIG. 16D).

The treatment of the apophyge at Oropos, where the flutes gradually become shallower and fade away is typical of the period down to about 300 B.C.; after this the cone of the echinos is often prolonged below the annulets so as to slice the tops of the flutes (Stoa of Philip at Delos,<sup>83</sup> Stoa at Samothrace,<sup>84</sup> Stoa of Cotys at Epidauros, etc., but not the Stoa of Antigonos at Delos).<sup>85</sup>

The proportions of the Oropos capital and those of some comparable examples are:

	Cap.H. D.	W.abac. D	Abac.H. Cap.H.	Ech.H. Cap.H.	Ann.H. Cap.H.	NeckH. Cap.H.
Tholos, Delphi	0.406	1.03	0.406	0.2375	0.0935	0.238
4th. C. Ap. Temple Delphi	0.402	1.055	0.427	0.241	0.0896	0.241
Ask. Temple, Epidauros	0.371	1.01	0.4011	0.275	0.0845	0.24
<i>Stoa, Oropos</i>			0.40	0.288	0.072	0.248
Ath. Temple, Tegea	0.379	1.04	0.418	0.275	0.0679	0.2395

The proportions of our capital thus come very close to those of capitals of the early fourth century.<sup>86</sup> But the figures for certain capitals of fifty or so years later are not sufficiently different to make dating by such proportions very trustworthy:

	Cap.H. D.	Abac.W. D.	Abac.H. Cap.H.	Ech.H. Cap.H.	Ann. H. Cap.H.	NeckH. Cap.H.
S. Stoa, Corinth	0.411	1.075	0.43	0.263	0.0607	0.266
Zeus Temple, Nemea	0.417	1.177	0.416	0.2895	0.0545	0.24
Zeus Temple Stratos	0.389	1.048	0.400	0.269	0.099	0.2309

A rather safer criterion to apply is the proportion of architrave height/frieze height, the figure for which grows fairly steadily smaller over the late fifth and fourth centuries, though with certain exceptions.<sup>87</sup> The figure for the Oropos stoa is 0.90, quite close to those for the Tholos at Delphi (0.901), the Temple of Amphiaraos at Oropos (0.892) and the Temple of Athena at Tegea (0.89), all before 350 B.C. A similar proportion is found in some later buildings, e.g. the Stoa at Samothrace (0.908), the Stoa of Attalos I at Delphi (0.90), the Temple of Athena Polias at Pergamon (0.896), but these come from very different areas and in Greek architecture regional differences can be as great at any one time as differences to be found in a single area at different dates. Peloponnesian buildings of the later fourth century normally show a lower figure, e.g. the Temple of Zeus at Stratos (0.837), the South Stoa at Corinth (0.852), the Stoa at Perachora (0.847), the Temple of Asklepios at Corinth (0.797); but the Temple of Zeus at Nemea has 0.897.

The Doric frieze is capable of many variations, some of which have important stylistic implications. First, we find that the Oropos stoa has the triglyph taenia higher than the metope taenia. This is of course normal in the Classical period. In the very earliest Doric entablatures,

<sup>81</sup> F. Noack, *Eleusis* 126, fig. 56.

<sup>82</sup> *Anaktoro*, pl. 21. 2. <sup>83</sup> *Délos* VII. i. 36, fig. 38.

<sup>84</sup> *BCH* lxxxvi (1962) 295, fig. 23; 297, fig. 25.

<sup>85</sup> *Délos* v, fig. 24, 25.

<sup>86</sup> The Oropos capital gives the following figures for the proportions used by Roux in his *Annexe I* (Roux 410-11): Ech.H./Cap.H. 0.288; Ab.H./Ech.H. 1.39; Cap.H./Neck

D. 0.495; Ab.L./Ech.H. 9.32; Ab.L./D. below Ech. 1.175; D. below Ech./Ech.H. 7.92. These figures mostly fall near the bottom of their tables, i.e. towards the mid fourth century.

<sup>87</sup> e.g. the Portico of Philo at Eleusis, where the frieze and architrave have equal heights to match the hall behind, constructed in the fifth century. Cf. Roux 412-13.



however, such as the earliest Hekatompedon<sup>88</sup> and Building A<sup>89</sup> on the Athenian Acropolis, and the Temple at Assos,<sup>90</sup> no clear distinction is shown. In Athens the two taenias are first properly distinguished in the Pisistratean Hekatompedon,<sup>91</sup> and thereafter that is the standard practice until late Hellenistic times. In the sixth-century temple of Apollo at Delphi<sup>92</sup> the two taenias are also distinguished, suggesting that the change occurred more or less simultaneously throughout Mainland Greece. But in Sicily and Italy the distinction never became standard.<sup>93</sup> It was widely ignored in the Hellenistic period, too, particularly in Asia Minor, where even the Stoa by the Harbour at Miletos, dated by its excavators to the fourth century, does not maintain it.<sup>94</sup> The change back was both later and less uniform in Mainland Greece; the distinction is dropped not only in the Stoa of Philip at Megalopolis,<sup>95</sup> the Echo Stoa at Olympia<sup>96</sup> and the East Stoa of the Asklepieion at Athens<sup>97</sup> which were all subject to late repairs, but perhaps also in the Palace at Vergina,<sup>98</sup> dated by Andronikos to the early third century. However, since even in the second century the taenias of the Temple of Despoina at Lykosoura<sup>99</sup> are differentiated, the difference in the two taenias at Oropos has little chronological significance.

The tops of the triglyph grooves of the Oropos stoa are horizontal and undercut, but the lip is not bevelled (FIG. 8 c, d). In the fifth century, triglyph grooves normally had curved tops such as those of the Parthenon. This curve was sometimes flattened, but the corners where the sides of the groove met the top were always rounded. This treatment continued into the fourth century with variations in the exact form of the curve. It occurs in the Tholos at Delphi, the Temple of Asklepios at Epidauros, the Metroon at Olympia, the Temple of Athena Alea at Tegea, and other buildings of the early fourth century and continues well into the second half of the century, in the Temple of Asklepios at Corinth, the Portico of Philo at Eleusis and the Choregic Monument of Nikias at Athens. The plain horizontal top is first used in the middle of the century<sup>100</sup> in the South Stoa at Olympia, the Temple of Athena Pronaia at Delphi (?),<sup>101</sup> the portico of the Thersilion at Megalopolis and the Tholos at Epidauros, followed by the Temple of Zeus at Stratos and the Stoa at Perchora.<sup>102</sup> The Stoa at Oropos, therefore, differs significantly from the buildings of the early fourth century, especially from the Temple of Amphiaraos at Oropos (the grooves of which have arched tops)<sup>103</sup> (FIG. 17) and should have an upper limit of about the middle of the century. A rough lower limit can be set by the fact that the triglyph tops of this stoa are undercut. Though horizontally grooved tops were used right through the Hellenistic period, from the first half of the third century onwards they were no longer undercut.<sup>104</sup>

The most interesting feature of the frieze of the Oropos stoa is the small ear which decorates the top of the half-grooves at either side of the triglyphs. The existence and shape of this ear are

<sup>88</sup> T. Wiegand, *Porosarchitektur der Akropolis zu Athen* 12, fig. 9, 14a: metope taenia c. 0.005 m. lower than triglyph taenia.

<sup>89</sup> Ibid. 149, fig. 133, pl. xii, xiii, 2: triglyph taenia = c. 0.055 m., metope taenia = c. 0.05 m.

<sup>90</sup> *Assos* 153-7.

<sup>91</sup> T. Wiegand, op. cit., figs. 118, 119; triglyph taenia = 0.186 m., metope taenia = 0.167 m.

<sup>92</sup> *F. de D., Le Terrace du Temple*, pl. xi.

<sup>93</sup> R. Koldewey, O. Puchstein, *Die Griechische Tempel in Unteritalien und Sicilien*, passim.

<sup>94</sup> *Milet* i. 6, fig. 10, 12. For date, 91.

<sup>95</sup> *Megalopolis*, fig. 57. For the probable restoration, 66.

<sup>96</sup> *Olympia*, Plates, Architecture, pl. 1.

<sup>97</sup> *AJA* xv (1911) 37, fig. 1.

<sup>98</sup> Heuzey-Daumet, pl. 9 shows the triglyph taenia higher

than the metope taenia, but in *Anaktoro*, pl. 21. 1 the two taenias appear to be equal.

<sup>99</sup> *AJA* x (1906) 302 ff.

<sup>100</sup> A single earlier example in Sicily, in the temple at Segesta, need hardly be considered in this context since it is unlikely to have affected the architects of mainland Greece.

<sup>101</sup> G. de Mire, P. de la Coste-Messelière, *Delphes*, pl. 232.

<sup>102</sup> Also the otherwise undated fourth-century temple at the Ptoan sanctuary. All these have a bevelled lip to the groove top, while those of the Oropos stoa are unbevelled.

<sup>103</sup> Cf. Versace 258, not a very accurate drawing.

<sup>104</sup> e.g. North-west Stoa, Thasos (*Thasos, L'Agora* I, Plan H) Stoa, Lindos (C. Blinkenberg, K. F. Kinch, E. Dyggve, *Lindos; Fouilles et Recherches, 1902-14, 1952*, III. i, pl. VI. E. ii-iii), Temple of Artemis, Epidauros (Roux, pl. 55).

both certain (FIG. 8C, PLATE 47, *b*). In its size it is comparable to the ear used on the triglyphs of all the Doric buildings of Attica in the fifth century<sup>105</sup> and continued into the fourth century.<sup>106</sup>

This ear is never found in the Peloponnese.<sup>107</sup> There the top of the half-groove is exactly the same as half of the top of one of the whole grooves, straight if they are straight-topped, or curved if they are curved. The ears of the Oropos Stoa are therefore not in the Peloponnesian tradition, nor do they come from Thebes, for the Treasury of the Thebans at Delphi,<sup>108</sup> the fourth century Temple at the Ptoan Sanctuary<sup>109</sup> and the third temple of the Theban Kabeirion<sup>110</sup> all have the half-grooves treated like half a whole groove.<sup>111</sup>

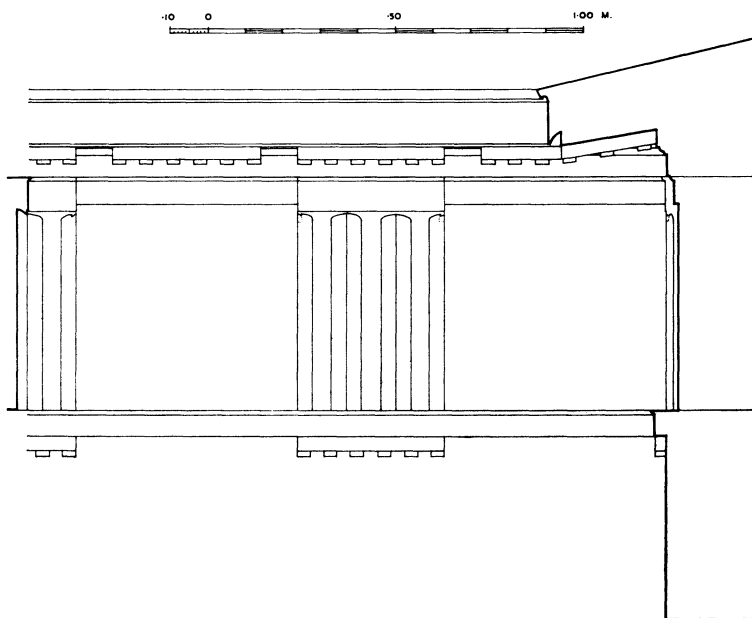

FIG. 17. ENTABLATURE OF THE TEMPLE OF AMPHIARAOS (SCALE 1 : 20)

Macedonian architecture on the other hand took over the little ear from Athens. It occurs in all the published Macedonian friezes, those of the tomb at Leukadia,<sup>112</sup> of the Palace at Vergina,<sup>113</sup> and of the reused fragments at Verria.<sup>114</sup> In the first example the ear takes the normal Attic form. In the other two the shape of the ear cannot be made out in the published photographs.

The recurved ear used at Oropos became very popular in Asia Minor. First in the Stoa by the Harbour at Miletos,<sup>115</sup> but later in almost every other Doric building, we find various

<sup>105</sup> The earliest buildings on the Acropolis do not have this ear, neither does the Treasury of the Athenians at Delphi. The use of it appears to date from the early fifth century as in Buildings B and C on the Acropolis, and thereafter all the Doric buildings have it.

<sup>106</sup> Not many buildings of the fourth century have survived; but the East Stoa of the Asklepieion at Athens, the Portico of Philo at Eleusis, and the Choregic monument of Nikias all have the ear.

<sup>107</sup> At Bassai the ear is shown by Cockerell and Robertson but omitted by von Hallerstein and Blouet.

<sup>108</sup> Built with the spoils of the battle of Leuktra (Paus. xii. 11. 5), so probably dated 370–365. For the details of the

frieze, see Roux 324, fig. 101.

<sup>109</sup> Dated *c.* 310 by Orlandos, *AD* 1915, 108–110.

<sup>110</sup> Dated by Doerpfeld to early Hellenistic times. W. Doerpfeld, *Das Kabirenheiligtum bei Theben* i. 16. But the form of the triglyph tops and the use of H-clamps suggest a mid-fourth-century date.

<sup>111</sup> The half-grooves of the Leuktra monument unfortunately have damaged tops: *BCH* lxxxiii (1959) 677, fig. 8.

<sup>112</sup> *BCH* lxxxvi (1962) 808, fig. 21; P. M. Petsas, 'Ο τάφος τῶν Λευκαδίων, fig. 19, pl. 31a.

<sup>113</sup> *Anaktoro*, pl. xxi. 1. Heuzey–Daumet, pl. 9.

<sup>114</sup> *BCH* lxxxv (1961) 799, fig. 2.

<sup>115</sup> *Milet* i. 6, fig. 11.

forms of ear, many of them much larger and more elaborate; they were presumably used to enliven the Doric order to suit Ionian taste. But even in the earliest examples in Asia Minor the ear is more prominent than at Oropos, which therefore has a greater affinity to Athens and Macedonia than to the Peloponnese or Ionia.

The Doric cornice of the stoa has two unusual features, the ovolo at the rear edge of the mutules and the receding corona below the crowning hawksbeak. In all Doric buildings after the Propylaea at Athens, a moulding was applied at the angle formed by the mutules and the lowest vertical fascia of the cornice. Normally this was a cyma reversa, and there are few parallels for the ovolo of the Oropos stoa.<sup>116</sup> Several fourth-century temples in Asia Minor have an ovolo where the soffit of the corona meets the bed,<sup>117</sup> but these are much larger, and are decorated with egg and dart; besides, the order is here Ionic not Doric. The only close parallels for the stoa moulding even in the Hellenistic period are the soffit mouldings from the cornices of the Oropos skene building,<sup>118</sup> which were presumably influenced by the stoa, and those from the cornices of the Macedonian tomb at Leukadia (early third century).<sup>119</sup>

The crowning mouldings of both Doric and Ionic cornices of the stoa are hawksbeaks which still have their upper part with an ovolo profile. From the middle of the fourth century, this upper part of the hawksbeak changed gradually from an ovolo to a cyma reversa, the process being complete by the end of the century. Miss Shoe gives the second quarter of the fourth century as the most suitable date for the stoa hawksbeaks.<sup>120</sup> Simultaneously with this new type of hawksbeak, however, the old profile was still used, as in the Choregic Monument of Nikias (320–310) etc., so that the use of the old profile at Oropos is not absolute proof of a date in the first half the fourth century.

Below the hawksbeak, the corona of the cornice is stepped back, a device which was presumably intended to replace the notch which used to underline a hawksbeak until the early fourth century.<sup>121</sup> Other buildings in which it occurs are the Tholos at Epidauros, the South Stoa at Olympia, both dated about the middle of the fourth century, then the Portico of Philo at Eleusis (330–310),<sup>122</sup> and the Leonidaion at Olympia, dated variously from the middle to the end of the fourth century,<sup>123</sup> but probably nearer to the earlier date. Later it is found in the Stoa at Samothrace,<sup>124</sup> the Stoa of Philip at Delos, and the Hypostyle Hall at Delos, all of the third century. From this evidence the cornice of the Oropos stoa should not be earlier than about the middle of the fourth century.

*The Ionic Order.* The Ionic bases of the stoa are close to the Attic form which was later to become canonical. The only difference is the substitution of a cavetto for a scotia,<sup>125</sup> and this would not be noticeable without a special examination. There is none of the radical originality to be found in Peloponnesian Ionic where experimentation was in other directions (e.g. in the Temple of Apollo at Bassai, the Tholos at Delphi, in Stoa IV at Kalauria, and the Abaton at Epidauros, etc.). In fact there are no bases approaching the Attic type in Peloponnesian architecture of the first half of the fourth century.<sup>126</sup>

<sup>116</sup> Shoe 41, pl. xx. 31.

<sup>117</sup> Temple of Artemis, Ephesos; Temple of Athena, Priene; Temple of Asklepios, Priene. Shoe 41–2, pl. xx. 32–5.

<sup>118</sup> Shoe 42, pl. xx. 37, 38.

<sup>119</sup> P. M. Petsas, 'Ο Τάφος τῶν Λευκαδίων, figs. 21–3.

<sup>120</sup> Shoe 113, pl. lv. 3–6.

<sup>121</sup> Shoe 105, whence I take my terms. The mouldings quoted can be seen in her pl. lv.

<sup>122</sup> F. Noack, *Eleusis*, fig. 61, but note the groove shown in fig. 62.

<sup>123</sup> Shoe 71, 73, 85, etc.; Roux 415.

<sup>124</sup> *BCH* lxxxvi (1962) 302–4.

<sup>125</sup> This curtailment of a moulding is paralleled by the use of an ovolo for a cyma reversa on the cornice soffit.

<sup>126</sup> The earliest are those of the South Stoa at Corinth, which, if Broneer is right (*Corinth* I. iv. 98), is of Macedonian rather than purely Peloponnesian origin, and the Tholos at Epidauros, which was considerably influenced by Athens (in the twenty-four-fluted columns and the shape of the rosette on the metopes, Roux 179–82).

There is a parallel for the Oropos bases in the Palaistra at Olympia,<sup>127</sup> belonging to the second century B.C. Here, of course, the base is much lower in relation to the column diameter, and the proportions of the three elements are different. Apart from this the nearest parallel in Peloponnesian architecture is the base of the Propylaia to the Lerna Fountain at Corinth,<sup>128</sup> where a large cyma reversa takes the place of the cavetto and the lower torus of the Oropos base. In fact the Oropos base is much closer to the Attic form than this, and thus is another instance of the Attic affinities of the stoa.

Attic bases are comparatively rare in the fourth century, and so we have only a scanty framework into which to fit the Oropos base in order to date it.<sup>129</sup> The following table lists various Attic bases of the fifth, fourth, third, and second centuries B.C. and indicates three of their most important proportions:

	Base H.		Lower Torus D.		T:S:t <sup>131</sup>
	Lower Col. D. <sup>130</sup>		Lower Col. D. <sup>130</sup>		
Ilissos Temple, Athens	0.499		1.388		t ≥ S ≥ T
Nike Temple, Athens	0.515	(0.478)	1.341	(1.261)	S ≥ t ≥ T
Propylaia, Athens	0.432	(0.391)	1.295	(1.17)	S ≥ t ≥ T
Col. fr. Agora, Athens	0.415	(0.362)	1.533	(1.345)	t ≥ S ≥ T
Erechth. E. Porch	0.419	(0.378)	1.423	(1.289)	S ≥ T ≥ t
Erechth. N. Porch	0.416	(0.362)	1.490	(1.311)	S ≥ T ≥ t
W. Stoa, Asklepieion, Athens		(0.386)		(1.338)	T ≥ S ≥ t
<i>Stoa, Oropos</i>	0.3203	(0.306)	1.25	(1.195)	T ≥ S ≥ t
Tholos, Epidauros	0.3256	(0.301)	1.307	(1.261)	T ≥ S ≥ t
S. Stoa, Corinth		0.311			S ≥ T ≥ t
Lysik. Mon., Athens	0.332	(0.291)	1.495	(1.315)	S ≥ T ≥ t
Proskenion, Epidauros	0.2857		1.4		S ≥ T ≥ t
Stoa of Kotys, Epidauros	0.3075	(0.258)	1.405	(1.195)	S ≥ T ≥ t
Propylaia, Epidauros					S ≥ T ≥ t
Adyton, Didyma	0.2424		1.237		T ≥ t ≥ S
Artemis Temple, Magnesia on Meander	0.312		1.39		S ≥ T ≥ t
Palaistra, Olympia	0.181	(0.172)	1.21	(1.151)	T ≥ S ≥ t
Stoa of Oroph., Priene	c. 0.3		—		S ≥ T ≥ t

From this table the dangers of supposing a continuous development of proportions will be apparent. Nevertheless a general tendency to a decrease in the height of the base is clear, and the base from the Oropos stoa belongs with the fourth-century examples rather than those of the fifth or third centuries. Another significant point which emerges is that for each proportion the figure from the Oropos stoa remains close to that of the Tholos at Epidauros. This is particularly noticeable in the last column where  $S \geq T \geq t$ , derived from the Erechtheion, became canonical, and only the bases from the West Stoa Asklepieion at Athens, the stoa at Oropos, the Tholos at Epidauros and the Palaistra at Olympia have  $T \geq S \geq t$ .

The Ionic columns of the stoa have twenty flutes and this looks like a Peloponnesian trait, since all but three or four Ionic and Corinthian buildings in the Peloponnesian sphere have twenty-fluted columns,<sup>132</sup> while all the columns of the well-known Ionic buildings of Athens have twenty-four flutes. However, the Ionic columns from the late Roman fortification wall in the Athenian Agora<sup>133</sup> have only twenty flutes and so have those of the Monument of

<sup>127</sup> *Olympia*, Plates I, pl. lv. 15.

<sup>128</sup> *Corinth* xiv. 76, fig. 22; said to be wrongly drawn (P. M. Petsas, 'Ο Τάφος τῶν Λευκαδίων, 74 n. 2).

<sup>129</sup> Even in Athens, the base with a scotia between two tori may not have been standard in the early fourth century.

<sup>130</sup> Figures in brackets give the proportions

Base Height  
Diameter of Apophyge of Column, and

Lower Torus Diameter

Diameter of Apophyge of Column<sup>\*</sup>

<sup>131</sup> T=Height of Lower Torus, S=Height of Scotia, t=Height of Upper Torus.

<sup>132</sup> Roux 334-6, 417-19.

<sup>133</sup> *Hesperia* xxix (1960) 354.

Lysikrates. It would be natural for any architect accustomed to the Doric order to use the same number of flutes in Ionic.

The Ionic capitals of the Oropos stoa are unique. No other capitals present quite the same mixture of Attic and Peloponnesian forms. The nearest capitals in general layout are those from the Abaton at Epidauros,<sup>134</sup> where the volutes are similarly turned inwards and pulled together round the column. This produces the same ugly pulvinus (PLATE 49, *a*)—without belt at Epidauros as at Oropos—which results from too small volutes set too close together. In defence of the Oropos capital (and presumably that from Epidauros as well) it can be said that the awkwardness is considerably reduced when it is seen from below (cf. PLATE 49, *b*). The volutes at Epidauros are marked out with the same simple fillet, and there, too, the upper line of the *canalis* curves downwards to the volutes while it is still under the abacus; this means that there must be a considerable vertical face above the pulvinus which does not help its appearance.

The cyma reversa abacus of the stoa is also used at Epidauros and was normal in Peloponnesian Ionic, while the preference in Attic monumental architecture was for an ovolo. The crowning fascia, normally absent from Attic Ionic, is also found in Peloponnesian Ionic; though sometimes considerably lower than at Oropos (Temple L at Epidauros and Great Propylaea at Epidauros),<sup>135</sup> it has a similar height (= *c.*  $\frac{1}{2}$  H. of cyma reversa) at the Temple of Athena Pronaia at Delphi,<sup>136</sup> the South Stoa at Corinth,<sup>137</sup> and the Stoa in the Valley of the Muses.<sup>138</sup>

However, many of these apparently Peloponnesian features are found in Attica, in a series of mainly votive capitals from the Athenian Acropolis which are dated to the middle of the fifth century. These are most conveniently grouped in Puchstein's *Das Ionische Capitell*,<sup>139</sup> and will be referred to here by the figure numbers in his paper. The series is continued,<sup>140</sup> particularly by some Ionic capitals in the late Roman fortification wall in the Athenian Agora,<sup>141</sup> which are provisionally dated to *c.* 430 B.C. In all these capitals the volute is simply marked out by a fillet. A cyma reversa abacus is found in Puchstein nos. 3, 4, 5, 7,<sup>142</sup> and the crowning fascia in Puchstein nos. 5, 6, and in one of the capitals from the Athenian Agora.<sup>143</sup>

Further, some features of the Oropos capital can only be matched from Athens. The normal echinus mouldings of an Ionic capital of the 'original' Peloponnesian type are a cyma reversa below a cavetto,<sup>144</sup> while the echinus of the Oropos capital has an ovolo with a taenia above. Exactly this combination (though the profiles are more refined) is found on the capitals from the Athenian Agora, showing that the development of the echinus with two elements continued well into the second half of the fifth century in Attica.

Another feature of the Oropos capital which has Athenian connections is the use of a palmette in the angle between the volute and the central part of the *canalis*. In Athenian Ionic this is missing only in the capitals of the Erechtheion. In the Peloponnesian, there is no palmette on any of those capitals which have a two-part echinus.<sup>145</sup> Even in capitals of a more normal type the palmettes are sometimes omitted (the South Stoa at Corinth; the Leonidaion at Olympia), though they do usually appear, particularly after the end of the fourth century.

<sup>134</sup> *PAE* 1905, 82-4, figg. 23-7; Roux 346-7, pl. 92.

<sup>135</sup> Roux, fig. 54 and fig. 69.

<sup>136</sup> Roux, fig. 103.

<sup>137</sup> *Corinth* I. iv, fig. 22.

<sup>138</sup> *BCH* lxxviii (1954) 35, fig. 15.

<sup>139</sup> 47 *Winckelmannsprogramm*, 1887.

<sup>140</sup> An Ionic capital from Athens (*AM* Iv (1933) 191-200) has a fascia above the abacus and an echinus consisting of a taenia above an ovolo.

<sup>141</sup> *Hesperia* xxix (1960) 354-6, pl. 77 (also *AD* (Chron.) 1960 pl. 13). A slightly different capital from the same place

is shown in *The Athenian Agora: a Guide . . .*, ed<sup>2</sup>, pl. x.

<sup>142</sup> But an ovolo forms the abacus of the capitals from the Agora.

<sup>143</sup> *Hesperia* xxix (1960), pl. 77.

<sup>144</sup> Bassai; Abaton, Epidauros; Palace, Vergina; Stoa, Perachora. This form was taken from the votive capitals on the Athenian Akropolis. Puchstein, nos. 2-6.

<sup>145</sup> Bassai; the Abaton, Epidauros; the Stoa, Perachora. There are palmettes on the Macedonian capitals, even the Propylaea to the Palace, Vergina, which has a two-element echinus.

The fact that the palmettes are not carved at Oropos has no significance, since such palmettes (on which the decoration was presumably painted) are found in all periods and all areas of Greece (votive capitals from the Acropolis; Temple of Athena at Sounion;<sup>146</sup> Temple of Athena Pronaia at Delphi;<sup>147</sup> Stoa IV at Kalauria;<sup>148</sup> Philippeion at Olympia; Proskenion of the Theatre at Epidauros).<sup>149</sup>

The dating of Ionic capitals by style is made difficult by their uneven distribution. In Athens there are many from the fifth century and one from the fourth,<sup>150</sup> while in the Peloponnese there is one from the fifth century<sup>151</sup> and many from the fourth. This makes it difficult to decide which differences are the result of date and which the result of place. The evidence obtained from the adjoining table of proportions is purely negative; it just shows how much the design of Ionic capitals was subject to individual taste. Perhaps the only datable characteristic of the Oropos capitals is the *canalis* which is bounded both above and below by generously curved lines. This suggests a date in the early part of the fourth century,<sup>151</sup> since in later capitals one or both of these lines are straightened out as in the South Stoa at Corinth, the Philippeion at Olympia, and a barbarous capital from Pella<sup>153</sup> in which the upper line of the *canalis* remains strongly curved while the lower line is straight.

(a) *Capitals of Peloponnesian type*

	Cap.H. Upper D.	Eye-Eye Upper D.	Intervol. Vol.W.	Cap.H. Ab.H.
Apollo Temple, Bassai	0.87	0.915	0.49	—
Pronaia, Temple, Delphi	0.61		1.4	6.75*
Abaton, Epidauros	0.59	0.95	1.75	10.0
Stoa IV, Kalauria	0.60	0.78	1.0	7.75
S. Stoa, Corinth	0.69	0.92	1.2	7.75*
Leonidaion, Olympia	0.575	0.91	1.3	7.75*
Philippeion, Olympia	0.625	1.02	1.18	8.875
Stoa, Perachora	0.635	0.88	1.6	8.2
Temple L, Epidauros	0.61	0.92	1.4	3.8*
Proskenion, Epidauros	0.64	1.0	1.19	9.4
Propylaia, Epidauros	0.60	0.97	1.7	4.5*
Stoa of Kotys, Epidauros	0.645	1.1	1.45	8.2
Palace, Vergina	0.61	0.78	1.02	5.9*
Tomb, Vergina	0.58	0.945	1.57	6.33*

\* Denotes abacus with fascia above.

(b) *Oropos capitals*

	Cap.H. Upper D.	Eye-Eye Upper D.	Intervol. Vol.W.	Cap.H. Ab.H.
Group I	0.58	0.88	1.2	7.6*
Group II	0.60	0.89	1.33	9.7*

<sup>146</sup> *AE* 1917, 184.

<sup>147</sup> Roux, pl. 94. 1.

<sup>148</sup> G. Welter, *Troizen und Kalauria*, pl. 42.

<sup>149</sup> A. V. Gerkan and W. Müller-Wiener, *Das Theater von Epidauros*, pl. 19.

<sup>150</sup> The capital probably from the West Stoa at the Athenian Asklepieion. (*BCH* lxxviii-lxix (1944-5) 343-5, 349-52.)

<sup>151</sup> The Temple of Apollo, Bassai, probably by an Athenian architect. The date is still debated. Dinsmoor suggests *c.* 420 for the interior (*Metropolitan Museum Studies* iv. 2 (1933) 225) but Roux would put it some twenty to thirty years later (Roux 55-6).

<sup>152</sup> But the capitals from the Stoa IV, Kalauria, and from the Stoa at Perachora, both have a well curved *canalis*.

<sup>153</sup> *BCH* lxxxiii (1959) 704, fig. 21; *AD* 1960, pl. 66.

(c) *Capitals of Attic type*

	Cap.H.	Eye-Eye	Intervol.	Cap.H.
	Upper D.	Upper D.	Vol.W.	Ab.H.
Stoa of Athenians, Delphi	0.97	1.253	0.72	11.31
Votive Cap. 5 on Acropolis	0.8	1.0	0.655	6.6*
Athena Temple, Sounion	0.8	0.95	0.53	13.5
Ilissos Temple, Athens	0.8	1.17	1.24	12.0
Propylaia, Athens	0.79	1.18	1.24	7.2
Capital fr. Agora, Athens	0.82	1.18	1.35	9.1
Nike Temple, Athens	0.84	1.23	1.18	9.1
Stoa Basileios, Athens	0.82	1.23	1.14	6.6
Erechtheion, Athens, E. Porch	0.80	1.07	0.97	7.8
"    "    N. Porch	0.79	1.07	1.0	9.25
W. Stoa, Asklepieion, Athens	0.70	1.00	1.12	10.4
Mausoleum, Halicarnassos	0.58	1.13	1.55	10.8
Athena Temple, Priene	0.6	1.08	1.4	7.9
Apollo Temple, Didyma, Outer	0.57	0.94	1.3	8.2
"    "    "    Inner	0.535	1.03	1.62	9.06
Great Zeus Altar, Pergamon	0.68	1.20	1.33	8.75
Artemis Temple, Magnesia on Meander	0.665	1.05	1.1	6.19
Dionysos Temple, Teos	0.672	1.025	1.7	6.07

\* Denotes abacus with fascia above.

The sofa capital which may belong to the Ionic antae at Oropos is one of a considerable series,<sup>154</sup> but unfortunately the chronology of this series is very vague. The two closest parallels are a capital from Slavochori in Laconia,<sup>155</sup> dated by Fiechter to the archaic period and one from Akrai included by Barnabo Brea in his catalogue of Hellenistic architectural fragments.<sup>156</sup> The chief difference from the Oropos capital is that both these capitals lack palmettes in the volute angles. A fragment of a capital from the Palace at Vergina appears also to be very similar and should belong to the early third century. The sofa capital from Pella with its heavy mouldings looks a later form.<sup>157</sup> The half-palmette which fills the volute angle of the stoa capital is very similar to those from the antefixes of the South Stoa at Corinth.<sup>158</sup>

The home of sofa capitals is shown by Roux<sup>159</sup> to be the Peloponnese, particularly Lakonia, but by the fourth and third centuries they had a wider distribution, occurring not only over the whole of the Peloponnese, but also in Northern Greece, Asia Minor, and Magna Graecia. The capital from Oropos is the only one from Attica and Boeotia.<sup>106</sup>

*Technique.* The stoa at Oropos is one of several fourth-century buildings in which both H- and pi-clamps are used. The blocks of the lower step are joined together by H-clamps 0.21 to 0.23 m. long with cross-pieces 0.05 to 0.06 m. long. The blocks of the entablature on the other hand are joined by pi-clamps. The end projections of the clamps are the same width as the central bar, and the depth of the central bar is greater than its width. As Roux has shown, this is an early form of pi-clamp<sup>161</sup> which was used in the Tholos at Delphi, the Temple of Athena at Delphi,<sup>162</sup> the Temple of Athena at Tegea, the Temple of Asklepios at Epidauros, the Tholos at Epidauros, and the Treasury of the Cyrene at Delphi.

<sup>154</sup> Discussed by Fiechter in *Jdl* xxxiii (1819) 209-18. The list is brought up to date in Roux 383 n. 2. A fragment from Vergina (*Anaktoro*, pl. xxiii. 2) should be added.

<sup>155</sup> *Jdl* xxxiii (1918) 209-11, fig. 56, 56a.

<sup>156</sup> Barnabo Brea, *Akrai* 138, no. 8, pl. xxvi. 2.

<sup>157</sup> *BCH* lxxxiii (1959) 704, fig. 22. *AD* 1960, pl. 66.

<sup>158</sup> *Corinth* I. iv, pl. 21. 1.

<sup>159</sup> Roux 383-6.

<sup>160</sup> Except for a very late capital from Rhamnous of a much more vertical type (J. Pouilloux, *La Forteresse de Rhamnonte*, pl. 52. 2).

<sup>161</sup> G. Roux and J. Pouilloux, *Enigmes à Delphes* 12-14.

<sup>162</sup> The earliest building with a pi-clamps, variously dated from the last quarter of the fifth century (J. Charbonneaux, *F. de D., Le Sanctuaire d'Athéna Pronaia* ii. 31-2) to c. 370 (Roux 415, 418).

Other buildings in which both types of clamp are used are the Tholos at Epidauros *c.* 360–335 B.C., the Stoa of Philip at Megalopolis, *c.* 340 B.C., the Temple of Zeus at Stratos, and the Third Temple of Apollo Patroos at Athens. H-clamps definitely continued in use until 320–319, when they were used in the Choregic Monument of Nikias.<sup>163</sup> However the weight of evidence would argue for a date earlier in the same century.

At first sight this change in clamp form suggests that the stoa was built in two stages, separated perhaps by a considerable space of time, but there is no further evidence to support this. Of the other buildings which use two clamp forms, the Tholos at Epidauros does seem to have been built in two stages,<sup>164</sup> but in the Stoa of Philip at Megalopolis<sup>165</sup> and the Temple of Zeus at Stratos,<sup>166</sup> there cannot have been such a break between the use of the two different types of clamp.

The drums of the columns are joined together by a single square empolion, which is the normal way of fixing them in all periods of Greek architecture. Other methods were introduced in the fourth century,<sup>167</sup> but they did not oust the single square empolion completely. Nor can anything more be deduced from the lack of any dowel between the column and stylobate. This, too, was standard Greek practice, and even when it became common to dowel the column to the stylobate,<sup>168</sup> the old technique continued.<sup>169</sup>

The masonry of the walls finds its closest parallels in fortification walling; walls of quarry-faced trapezoidal masonry are dated by Scranton to the last quarter of the fifth century and the first quarter of the fourth.<sup>170</sup>

The use of mudbrick or rubble is not unparalleled in a large public building. Mudbrick was used in the South Stoa I at Athens<sup>171</sup> and the Stoa of Kotys at Epidauros;<sup>172</sup> possibly also in the South Stoa at Argos<sup>173</sup> and the East Stoa at Thermon.<sup>174</sup> Rubble walls were used in the Stoa by the Harbour at Miletos<sup>175</sup> and the South Stoa at Priene.<sup>176</sup> It would be a great saving to use a cheap wall material in a building as big as the Oropos stoa, and the builders of the stoa, who had an inscription carved on the frieze to record their generosity, may have wanted to create the biggest impression with the least expense.

*Plan.* An unusual feature of the stoa is the way in which the end walls return around the front for some distance. Normally the end walls of a stoa ended in antae and the colonnade occupied the whole of the front. However several stoas of various periods do have the front partially closed. Early examples are the North Stoa at the Argive Heraion and the Stoa by the Theatre at Athens, which have only one end closed. The same scheme as at Oropos is found at the North Stoa III at Corinth, the North Stoa and the 'Bazaar' at Assos<sup>177</sup> and the Stoa of Philip at Delos. It was particularly popular in North-west Greece, occurring at Kassope,<sup>178</sup> Molykreion,<sup>179</sup> New Pleuron,<sup>180</sup> Thermon (East and Middle Stoas)<sup>180</sup> and the Valley of the Muses.<sup>181</sup> Two much smaller and simpler stoas in the sanctuary at the mouth of the Silaris<sup>182</sup> are the only ones with end rooms similar to those of the stoa at Oropos.

<sup>163</sup> *AJA* 24 (1910) 459 ff. They are also used in the fourth-century temple at the Ptoan Sanctuary which Orlando dates to *c.* 310 (*AD* 1915, 108–10).

<sup>164</sup> Roux 184. <sup>165</sup> *Megalopolis* 60.

<sup>166</sup> F. Courby, C. Picard, *Recherches archéologiques à Stratos d'Acarnanie* 83.

<sup>167</sup> e.g. the use of two rectangular metal dowels with a square wooden one between as in the Temple of Athena at Tegea, in the Tholos at Epidauros and in the Leonidaion at Olympia.

<sup>168</sup> e.g. Temple of Athena at Tegea; the Tholos at Epidauros and the Echo Stoa at Olympia.

<sup>169</sup> e.g. the Stoa of Philip in Delos; the Stoa of Kotys at Epidauros, etc.

<sup>170</sup> R. L. Scranton, *Greek Walls* 85. Cf. R. Martin, *Manuel d'architecture grecque* i. 382–4.

<sup>171</sup> *Hesperia* xxiii (1954) 40.

<sup>172</sup> Paus. ii. 27. 6.

<sup>173</sup> *BCH* lxxvii (1953) 252.

<sup>174</sup> Unpublished.

<sup>175</sup> *Milet* i. 6. 13.

<sup>176</sup> *Priene* 202.

<sup>177</sup> *Assos* 33.

<sup>178</sup> *PAE* 1955, 182–6.

<sup>179</sup> *AD* ix (1924–5), parat. 63.

<sup>180</sup> Unpublished.

<sup>181</sup> *BCH* lxxviii (1954) 27–36.

<sup>182</sup> P. Zancani-Montuoro, U. Zanotti-Bianco, *Heraion alla Foce del Sele* i. 41–6 (dated to the archaic period and the fifth to fourth century B.C.). A similar division is to be seen in the Temple of Artemis (Room K) on the Hellenistic Agora at Messene (*Ergon* 1963, fig. 98).



The arrangement of the internal colonnade at Oropos is also very unusual. The normal scheme was to have two external spans to each internal one, but at Oropos even the more complicated relation of five external spans to two internal ones was not exactly maintained. This suggests that the Oropos stoa was built before the two-to-one scheme had been fully accepted. Before 400 B.C., only the South Stoa at the Argive Heraion<sup>183</sup> and the Stoa Basileios at Athens<sup>184</sup> definitely have this scheme. North Stoa III at Corinth, built probably in the third quarter of the fourth century, has two internal spans to three external ones,<sup>185</sup> but by the third century, and probably by the end of the fourth, the two-to-one scheme was generally accepted, and this gives some indication of the date of the stoa at Oropos. However, Stoa J at Calydon,<sup>186</sup> which belongs to the third or second century, still uses an irregular arrangement.

*Conclusion.* From all this comparative material, it should now be clear that the stoa at Oropos belongs to the fourth century and probably to about the middle of it. The features which are the clearest pointers to this are the form of the Doric capital, the treatment of the triglyph tops, the crowning moulding of the Doric cornice with its receding corona, and the form of the clamps. The buildings with which it has the closest connections are the South Stoa at Olympia (c. 360–350)<sup>187</sup> and the Tholos at Epidauros (360–335),<sup>188</sup> although their Doric capitals appear to be of a later type than those of the Oropos stoa. In view of their different mouldings<sup>189</sup> and triglyph groove tops,<sup>190</sup> Versace is wrong in making the temple and stoa at Oropos contemporary. There is therefore no need to connect the construction of the stoa with that of a water channel in 387 B.C.<sup>191</sup>

To get any closer than this to the date of the stoa, we must look at the history of Oropos. Lying on the borders of Attica and Boeotia, Oropos had a chequered career.<sup>192</sup> In 411 B.C. it regained independence from Athens with the secession of Eretria from the Athenian League; then in 402 B.C., after a period of party struggle, it was taken by a pro-Theban party and eventually became part of Boeotia. The King's Peace brought Oropos another brief period of independence, but in 386 B.C. Athens took possession of it once more, almost coming to blows with Thebes as a result. As the power of Thebes grew, Athens sided more with Sparta and jealousy between Athens and Thebes increased. Eventually in 366 B.C. Thebes seized Oropos from Athens and held it until 338 B.C. when after the battle of Chaironeia, Philip of Macedon gave it back to Athens.

Clearly therefore, before we can decide what is the most suitable date for the construction of the stoa, we must decide who built it. Stylistically it is, as we have seen, a mixture of Attic and Peloponnesian elements, and was obviously not a native Athenian product. Previously, where this has been recognized, it has been assumed that the stoa was built during a period of Boeotian occupation,<sup>193</sup> and it would be natural enough for Boeotian architecture to be such a mixture of Attic and Peloponnesian features. For though Boeotia was in part racially connected with the Dorian Peloponnesians, the flourishing art of her neighbour Athens must have had a considerable effect.

However the Thebans were not the only people to be open to both Attic and Peloponnesian influences, and various features in the stoa suggest a Macedonian architect. For the only non-

<sup>183</sup> C. Waldstein, *The Argive Heraeum* i, pl. xxi.

<sup>184</sup> *Hesperia* vi (1937), p. 11. Probably also the South Stoa at Athens (*Hesperia* xxiii (1954), 40).

<sup>185</sup> *Corinth* I. iii. 164, Plan K. For the date, *ibid.* 174.

<sup>186</sup> E. Dyggve, *Das Laphrion* 73, fig. 267.

<sup>187</sup> K. Kunze, H. Schleif, *Olympia Bericht* ii. 36–8; iii. 37–66.

<sup>188</sup> Roux 184.

<sup>189</sup> Shoe, esp. 110, 113.

<sup>190</sup> Versace 268.

<sup>191</sup> Versace 270; but the date given for the relevant inscription by Dittenberger (*IG* vii. 4255) is much later in the century.

<sup>192</sup> The history of Oropos is summarized in *PWK*, s.v. Oropos, where the relevant references are given.

<sup>193</sup> Roux 335.

Attic architecture in Mainland Greece to show an ear at the top of the triglyph half-grooves is that of Macedon where all the published friezes (admittedly only three) have such ears.

Unfortunately we know nothing of Macedonian Ionic before the late fourth century, so that we can make no direct comparison with the most characteristic member of the Oropos stoa, the Ionic capital. Later Ionic capitals from Macedonia do not show the same combination of features as the Oropos capital, but they do show a mixture of Attic and Peloponnesian influences. On the capitals from the Propylaia to the Palace of Vergina,<sup>194</sup> the echinus is formed by a cyma reversa below a cavetto, while the other capitals from the same building,<sup>195</sup> and the capitals from the Tomb at Vergina<sup>196</sup> and from the houses in Sections I,<sup>197</sup> II,<sup>198</sup> and IV<sup>199</sup> at Pella have the canonical ovolo. All the known Macedonian Ionic capitals have palmettes in the angles between volutes and *canalis*; except at the Philippeion at Olympia, all have the volute delineated by a simple fillet. The abacus is either an ovolo or a cyma reversa and may have a fascia to cap it (capital from Section II at Pella and from the Tomb at Vergina). In general, Macedonian Ionic shows an uncouthness with which the Oropos capital would be quite at home. The laziness in the use of mouldings which we found in the Oropos stoa, is also noticeable in the Philippeion at Olympia,<sup>200</sup> where the lower torus of the Ionic base is omitted, the fascias of the Ionic architrave are reduced from three to two, and the frieze section simplified from a cyma recta to a cavetto.

Unless there are two adjacent volute faces,<sup>201</sup> the volutes of Macedonian capitals always lie in the same plane. This is Attic and Ionian practice, in contrast to that of the Peloponnesians, where the volutes were turned inwards, and is the most important difference between the Oropos capitals and those from Macedonia. All the Macedonian capitals, however, are of the third century, much later than those from Oropos, and were probably influenced by the capitals of the Philippeion, which are much closer to the Athenian forms than those of Oropos.

It is also interesting that of the comparatively few sofa capitals known, two come from Macedonia, one of them the closest in design to the one from Oropos. Besides these, we find sofa capitals also at Apollonia in Epirus, Samothrace, and Olynthos, all well within the sphere of Macedonian relations; while, as we have seen,<sup>202</sup> there is none from Boeotia or anywhere else in Central Greece.

The stylistic evidence, therefore, though by no means conclusive, suggests a Macedonian rather than a Theban origin for the stoa. We know of no occasion for any official donation from Macedonia to Oropos—indeed the kings of Macedonia from about 370 to 350 B.C. had their hands full coping with the problems of their own kingdom—so that the stoa, if Macedonian, must have been a private benefaction. It may, therefore, be significant that a pair of inscriptions dating from the mid fourth century<sup>203</sup> has been found at Oropos honouring two Macedonians. Amyntas son of Antiochos and Amyntas son of Perdikkas, were declared *proxenoi* and benefactors of the Oropians and granted *asylia* for themselves and their descendants. No indication is given of the particular service rendered by the two men, but in view of the date it is not unreasonable to suggest that it may have been the construction of a grand stoa for the patients at the sanctuary of Amphiaraos.

<sup>194</sup> *Anaktoro*, pl. 22. 1, 2. Heuzey–Daumet, pl. 10.

<sup>195</sup> *Anaktoro*, pl. 21. 3, 22. 3. Heuzey–Daumet, pl. 12.

<sup>196</sup> K. Rhomaios, Ὁ Μακεδονικὸς Τάφος τῆς Βεργίνας, fig. 13.

<sup>197</sup> *AD* 1960, pl. 48 (lower storey), pl. 49 (upper storey).

<sup>198</sup> *AD* 1960, pl. 59b, *BCH* lxxxv (1961) 810, fig. 13.

<sup>199</sup> *AD* 1960, pl. 66a, *BCH* lxxxiii (1959) 704, fig. 21.

<sup>200</sup> *Olympische Forschungen* i, pl. 7, 8.

<sup>201</sup> e.g. in the capitals from the Propylaia of the Palace,

Vergina, (see n. 194) and from the angles of the peristyle of the house in Section I, Pella (see n. 197).

<sup>202</sup> Roux 383 n. 2.

<sup>203</sup> *IG* vii. 4250 = M. N. Tod, *A Selection of Greek Historical Inscriptions*, 164B; *IG* vii. 4251 = Tod, op. cit. 164A. My attention was kindly drawn to these two inscriptions by B. Chr. Petrakos, and I have been much helped by discussion of the historical situation with J. R. Ellis.

The inscriptions are identical in style and wording, and on epigraphical grounds must date from between 366 and 338 B.C.<sup>204</sup> Although Amyntas was not an uncommon name in Macedonia, it is likely that the first of the two men referred to is the Amyntas son of Antiochos who on Alexander's accession in 336 B.C. fled to Persia;<sup>205</sup> the second is probably the son of Perdikkas II who was an infant at his father's death in 359 B.C.,<sup>206</sup> whom Philip II, at first his regent, later displaced. A connection between these two men is suggested by the fact that when Alexander on his accession to the throne killed the son of Perdikkas II as a serious rival,<sup>207</sup> the son of Antiochos found it wise to escape to Persia at the same time.

Another inscription mentioning Amyntas the son of Perdikkas comes from Lebadeia,<sup>208</sup> and on epigraphical grounds it can be dated to the same period. But since Amyntas is given the title of king of the Macedonians,<sup>209</sup> this inscription must belong to the years immediately after his father's death, and before Philip had fully established himself as king, for it is strange in any case that Demosthenes does not mention any dispute over the throne in his list of Philip's iniquities, but incredible if it were still current in the years just before the composition of *Philippic I*.

Since, therefore, this Amyntas is known to have been in Boeotia in 359 B.C. or soon afterwards, it is most reasonable to suppose that the visit to the Amphiraion was part of the same tour; a tour of Greece at this time would not only ensure his personal safety, but might also gain him political support. Amyntas the son of Perdikkas was still only about eight years old,<sup>210</sup> too young to have undertaken such a journey by himself, but it is unknown whether the son of Antiochos or someone else<sup>211</sup> was its instigator and organizer. However that may be, the probable date of Amyntas's tour fits in well with the architectural evidence for the date of the stoa.

Although Macedonia at this time was not yet a really powerful state, individual members of its nobility and royalty would have been quite able to supply funds for the stoa; and the bold lettering on its frieze would suit well a politically inspired gift.<sup>212</sup> That the Macedonian court was already familiar with the styles and conventions of Greek architecture is shown by the architectural members found at Pella<sup>213</sup> dating from about 400 B.C., the period when Archelaos moved his capital there.

None of the surviving inscribed frieze blocks can have formed part of the names AMYNTΑΣ ΠΕΡΔΙΚΚΑ ΚΑΙ ΑΜΥΝΤΑΣ ΑΝΤΙΟΧΟΥ ΜΑΚΕΔΟΝΕΣ; in view of the small number of letters that remain and our complete ignorance of the purport of the inscription, this is probably not an overwhelming objection, although it may be too great for those who are not convinced by the Macedonian characteristics I have seen in the architectural style.

There remain two other possibilities; either the stoa was built by the people of Oropos itself, or it was built by the Thebans. The former hypothesis gives us no help with the date, since we know of no particular occasion for such a project. But in the latter case, the stoa may have been a memorial to some Theban victory,<sup>214</sup> perhaps Epaminondas's Thessalian campaign in 367

<sup>204</sup> Tod, *op. cit.* ii. 187.

<sup>205</sup> Arrian i. 17. 9.

<sup>206</sup> Justin vii. 5. 8-10.

<sup>207</sup> Arrian, *Hist. Succ. Alex.* i. 22.

<sup>208</sup> *IG* vii. 3055. 8.

<sup>209</sup> The Oropian inscription refers to him merely as Ἀμύνταν Περδίκκα Μακεδόνα, but the word Μακεδόνα is written over an erasure, and it has been suggested that Βασιλέα was the original word (e.g. W. Dittenberger, *IG* vii. 4250).

<sup>210</sup> *Hermes* xxiv (1889) 640-3.

<sup>211</sup> The fact that only two of these proxeny decrees were found does not mean that there were originally no more.

<sup>212</sup> Compare the inscriptions on the Stoa of Antigonos at

Delos (*Délos* V. 37-9), the Stoa of Philip at Delos (*Délos* VII. i. 17-22, 48), the Stoa of Attalos at Athens (*The Stoa of Attalos II in Athens*, *Agora Pict. Bk.* no. 2, fig. 33), etc.

<sup>213</sup> P. M. Petsas, *Pella (Studies in Medit. Archaeol.* xiv) 5.

<sup>214</sup> A stoa had been erected in the agora at Thebes out of the spoils of the battle of Delion, 424 B.C. (Diod. Sic. xii. 70. 5), but it is not clear why this present stoa should have been set up at Oropos rather than at Thebes. Other stoas built as victory memorials were the Stoa Persike at Sparta (Paus. iii. 11. 3), the Stoa of Cleisthenes at Sikyon (Paus. ii. 9. 6), the Corcyraean Stoa at Elis (Paus. viii. 30.6); possibly also the Stoa Poikile at Athens which had pictures celebrating the victory of Marathon.

B.C.<sup>215</sup> or his subsequent expedition to the Peloponnese in 366 B.C.<sup>216</sup> For what it is worth, the surviving letters of the frieze can be fitted quite easily into a suitable inscription for a war memorial.<sup>217</sup> For a natural formula would be something such as:

ΟΙ ΘΗΒΑΙ]ΟΙ [ΑΜΦΙΑΡΩΙ ΑΝΕ]Θ[ΗΚΑΝ Α]ΠΟ [ΤΩΝ ΠΟΛΕΜΙΩ]Ν [ΔΕΚΑΤΑΝ.

The insensitive treatment of the Ionic capitals at Oropos would probably agree as well with a Theban as with a Macedonian origin. But if the absence of triglyph ears in the three Theban friezes known to us, and their presence in the three published Macedonian friezes, seem a strong argument, it is reasonable to see the stoa as a private donation by Amyntas son of Perdikkas with his supporter the son of Antiochos, intended to gain support for his claim to the Macedonian throne. The date of construction would in that case be about 359/358 B.C.

*Later Additions and Repairs.* The first of the changes in the stoa after its construction was the addition of the bench. The use of marble instead of poros for the bench, and the fact that it hides the base mouldings of the Ionic antae make it unlikely that the bench was contemporary with the construction of the stoa. However, it is difficult to get even a vague idea of the date when the bench was added, since the type of bracket found in it was in very general use. Similar brackets are found in the Theatre at Argos (dated to the end of the fourth century),<sup>218</sup> the Theatre at Epidauros (early third century),<sup>219</sup> the Abaton extension at Epidauros (probably Hellenistic or Roman)<sup>220</sup> and the Heroon at Kalydon (second century B.C.).<sup>221</sup> The bench supports attributed to Temple C at Cos (c. 170 A.D.)<sup>222</sup> are also of the same type. Nor are there any other datable characteristics in the bench.

The five or six step blocks at either end of the stoa have dowel holes in their upper surface for attaching the stylobate blocks. These holes are roughly worked and have pour-channels leading to them (PLATE 49, *d*). They clearly do not belong to the original construction of the stoa but to a late repair when it was necessary to reset some of the stylobate blocks; the repair was restricted to the first 5.5 m. at the south-west end and about the first 4.3 m. at the north-east end of the stoa. The re-laying of these blocks would necessitate the removal of the short walls along the front of the stoa, and so of at least the end sections of the roof. All the surviving parts of the end and rear walls must also be later repairs because of the tile fragments they contain. To repair all this would mean taking off the whole roof. We must imagine then that at some period the stoa was dismantled right down to orthostate level at the ends and back and even lower at the two ends of the façade, leaving only the two colonnades standing. It is unlikely that this would be necessary unless the stoa had been allowed to fall into serious disrepair. Inscriptions indicate<sup>223</sup> that such wholesale repairs were not infrequently carried out in the Roman period, the expense being usually borne by some rich local benefactor. It is probably to the Roman period that we should attribute the repair of the stoa at Oropos.

J. J. COULTON

<sup>215</sup> Hardly victorious, since his main aim was the release of Pelopidas rather than the defeat of Alexander of Pherai. Plutarch, *Pelopidas* 29.

<sup>216</sup> Xen. *Hell.* vii. i. 41-3; Diod. Sic. xv. 75, 2.

<sup>217</sup> The Stoa of the Athenians at Delphi, which was built to house battle spoils, has a monumental inscription on the stylobate (P. Amandry, *F.deD.*, *La colonne des Naxiens et le portique des Atheniens*, pl. xxiii). The Treasury of the Cnidians at Delphi, which has an inscribed architrave, may also have been erected from the spoils of war (Paus. ix. 11. 5, G. Roux, J. Pouilloux, *Enigmes à Delphes* 67-8).

<sup>218</sup> *BCH* lxxx (1956) 384, fig. 38-9, 391.

<sup>219</sup> A. v. Gerkan, W. Müller-Wiener, *Das Theater von Epidauros*, pl. 10; for date, 77-80.

<sup>220</sup> Defrasse, Lechat, *Epidaure* 136; P. Cavvadias, *Fouilles d'Epidaure*, pl. vii. 10; for date, Shoe 124-75; *PAE* 1905, 87; (*BCH* lxxviii-lxix (1944-5) 349 n. 1).

<sup>221</sup> E. Dyggve, F. Poulsen, K. Rhomaios, *Das Heroon von Kalydon*, 68-71; for date, 109-18.

<sup>222</sup> R. Herzog, *Kos* i. 43, pl. 27. 7-9.

<sup>223</sup> Dittenberger, *Syll.*<sup>3</sup> 841; 852. 30-45; 898. 1-14; *IG* xii. 3, 324. 7-10; *IG* xii. 8, 73; *IOSPE* i. 2, 184.



*a*



*b*

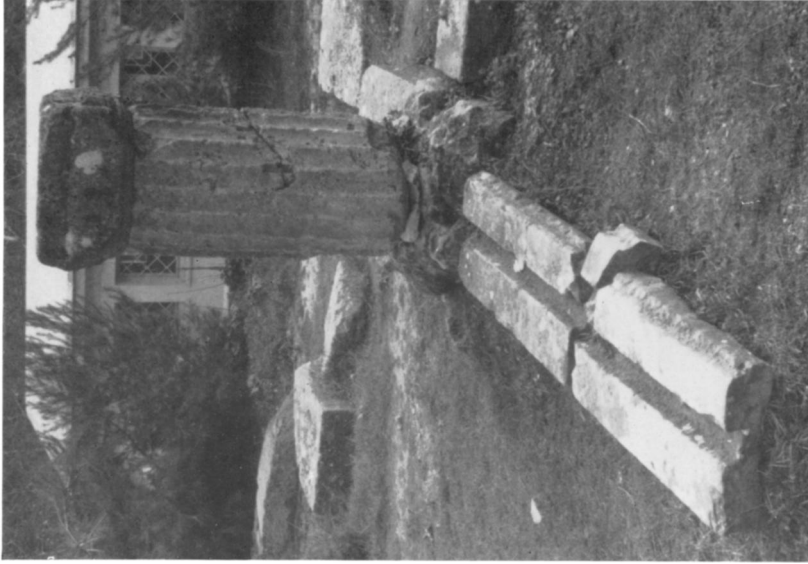

*(c)*

THE STOA AT THE AMPHARAION

- (a) GENERAL VIEW OF THE STOA FROM THE SOUTH-WEST; NOTE THE CURVATURE IN THE TOP OF THE ORTHOSTATES.
- (b) THE NORTH-WEST ANTA OF THE SOUTH-WEST PARTITION.
- (c) THE SOUTH-WEST PARTITION FROM THE NORTH-WEST.



*a*



*b*



*c*

(*a*) THE NORTH-WEST END WALL.  
 (*b*) THE NORTH-EAST PARTITION.  
 (*c*) THE NORTH-WEST END OF THE NORTH-EAST PARTITION.

(*d*) DORIC COLUMN DRUMS



*d*

THE STOA AT  
 THE  
 AMPHARAION



*a*

(*a*) DORIC CAPITAL PROFILE.



*b*

(*b*) PLAIN DORIC FRIEZE BLOCK.



*c*

(*c*) INSCRIBED DORIC FRIEZE BLOCK.



*d*

(*d*) DORIC CORNICE.

THE STOA AT THE AMPHARAION

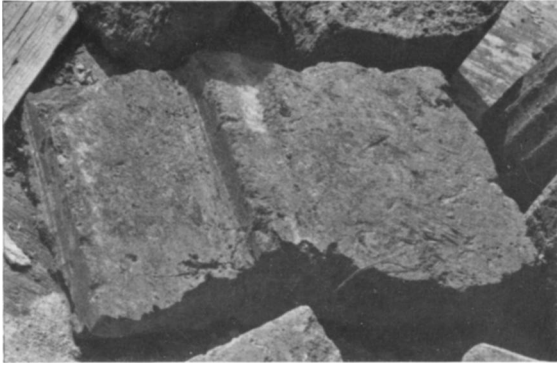

*a*



*b*



*c*



*d*



*e*

(*a*) CORNICE WITHOUT MUTULES FROM THE END OF THE STOA.  
 (*b*) CORNER BLOCK OF A CORNICE WITHOUT MUTULES.

(*c*), (*d*), (*e*) TYPE I IONIC CAPITAL.  
 (*c*) VOLUTE FACE, (*d*) BALUSTER END.  
 (*e*) UNDERSIDE.

THE STOA AT THE AMPHARAION





(a)



(b)



(c)



(d)

THE STOA AT THE AMPHIARAION

(a) TYPE II IONIC CAPITAL. (b) TYPE II IONIC CAPITAL SEEN FROM BELOW. (c) IONIC ANTA CAPITAL (?).  
(d) CUTTINGS FOR H-CLAMPS AND LATER DOWELS IN THE STEP BLOCKS OF THE KREPIS.

B.S.A. 63

