



---

Lifting in Early Greek Architecture

Author(s): J. J. Coulton

Source: *The Journal of Hellenic Studies*, Vol. 94 (1974), pp. 1-19

Published by: The Society for the Promotion of Hellenic Studies

Stable URL: <http://www.jstor.org/stable/630416>

Accessed: 24/03/2009 12:21

---

Your use of the JSTOR archive indicates your acceptance of JSTOR's Terms and Conditions of Use, available at <http://www.jstor.org/page/info/about/policies/terms.jsp>. JSTOR's Terms and Conditions of Use provides, in part, that unless you have obtained prior permission, you may not download an entire issue of a journal or multiple copies of articles, and you may use content in the JSTOR archive only for your personal, non-commercial use.

Please contact the publisher regarding any further use of this work. Publisher contact information may be obtained at <http://www.jstor.org/action/showPublisher?publisherCode=hellenic>.

Each copy of any part of a JSTOR transmission must contain the same copyright notice that appears on the screen or printed page of such transmission.

JSTOR is a not-for-profit organization founded in 1995 to build trusted digital archives for scholarship. We work with the scholarly community to preserve their work and the materials they rely upon, and to build a common research platform that promotes the discovery and use of these resources. For more information about JSTOR, please contact [support@jstor.org](mailto:support@jstor.org).



*The Society for the Promotion of Hellenic Studies* is collaborating with JSTOR to digitize, preserve and extend access to *The Journal of Hellenic Studies*.

<http://www.jstor.org>

## LIFTING IN EARLY GREEK ARCHITECTURE

In the standard handbooks on the techniques of Greek architecture,<sup>1</sup> the problem of lifting heavy architectural members is considered mainly in terms of the various cranes and hoists based on compound pulley systems which are described by Vitruvius and Hero of Alexandria.<sup>2</sup> It is assumed that the same basic method was employed also in the Archaic period, and that the use of an earth ramp by Chersiphron to raise the architraves of the temple of Artemis at Ephesos<sup>3</sup> in the mid-sixth century was exceptional. If this is true, it is a matter of some interest in the history of technology. The simple pulley, used not to gain mechanical advantage but just to change the direction of pull, is first known from an Assyrian relief of the ninth century B.C.,<sup>4</sup> and may well have been known to the Greeks before they began to build in megalithic masonry in the late seventh century B.C.; but the earliest indisputable evidence for a knowledge of compound pulley systems is in the *Mechanical Problems* attributed to Aristotle, but more probably written by a member of his school in the early third century B.C.<sup>5</sup> This is a theoretical discussion of a system which

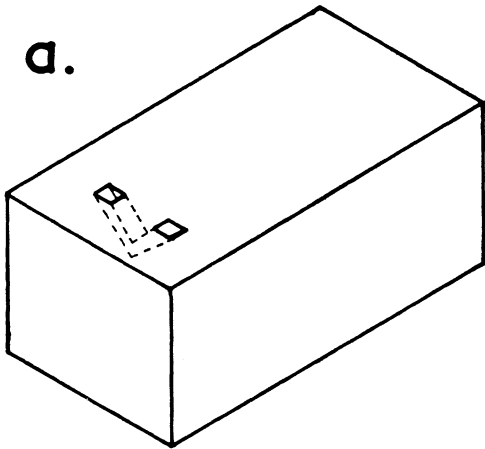
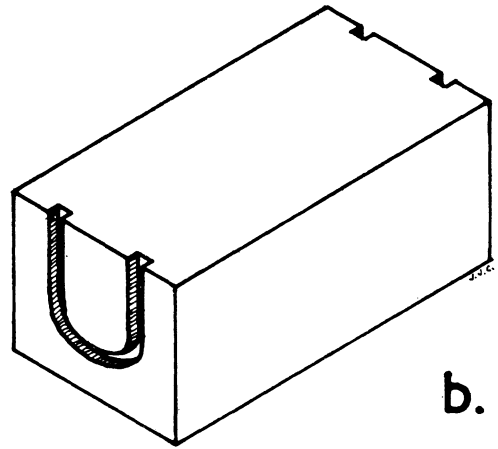

FIG. 1a.—Block with U-shaped hole.



1b.—Block with U-shaped channels.

was already used by builders, but it is not so certain that practice preceded theory by three centuries or more.<sup>6</sup> It is therefore worth looking again at the evidence for the use of cranes, hoists and pulleys in early Greek building.

The evidence sometimes cited is the existence of U-shaped holes<sup>7</sup> cut into the top of the

<sup>1</sup> W. B. Dinsmoor, *The Architecture of Ancient Greece* (3rd ed., 1950) 173-4; A. K. Orlandos, *Tà 'Υλικὰ Δομῆς τῶν Ἀρχαίων Ἑλλήνων* 2 (1958) 101-16, 163-75; R. Martin, *Manuel d'Architecture Grecque 1: Matériaux et Techniques* (1965) 201-19. These works are cited below by their authors' name only. In addition, the following abbreviations are used:

FD Ecole française d'Athènes, *Fouilles de Delphes*.

KP R. Koldewey, O. Puchstein, *Griechische Tempel in Unteritalien und Sicilien* (1899).

<sup>2</sup> Vitruvius 10.2; Hero, *Mechanica* 3.2-5 (Teubner, ed. Nix-Schmidt; only the first of these sections survives in Greek, the rest in an Arabic translation).

<sup>3</sup> Pliny, *Nat. Hist.* 36.14. The story is rejected outright by Orlandos, 101-3.

<sup>4</sup> *JCuneifS* 7 (1953) 5-7, fig. 1; A. G. Drachmann, *The Mechanical Technology of Greek and Roman Antiquity*

(1963) 203.

<sup>5</sup> [Aristotle] *Mech.* 18 (=853a32-853b13); A. G. Drachmann, *The Mechanical Technology of Greek and Roman Antiquity* (1963) 15.

<sup>6</sup> Pulleys (in the plural) are mentioned in connection with lifting machines in a fourth century B.C. architectural inscription (*IG ii<sup>2</sup> 1672.156* (329/8 B.C.)). In theory these could be simple pulleys used in parallel, not compound pulley systems.

<sup>7</sup> It is important to distinguish the U-shaped holes discussed in the following paragraphs (FIG. 1a) from the U-shaped channels discussed later (FIG. 1b). They are characteristic of different periods of Greek architecture, and are normally related in different ways to the centre of gravity of the blocks concerned. See note 37 below.

blocks used in several of the earliest Greek buildings in megalithic masonry, including the Heraion at Olympia and the temple of Artemis at Kerkyra.<sup>8</sup> These holes are interpreted as intended to take loops of rope by means of which the blocks were attached to the hook of a crane which lifted them into position. In fact, however, these U-shaped holes offer evidence that cranes were not used in connection with most of the blocks. For if a crane were to lift them, we should expect these blocks to have either two cuttings, one near each end, or a single cutting near the centre of the top face, so that the block would hang roughly horizontal while it was being lifted.<sup>9</sup> But although some blocks do have cuttings in such positions, the vast majority of wall blocks in all the buildings concerned have a single U-shaped hole set close to one end of the top face;<sup>10</sup> if a rope was attached to the cutting and the block raised by a crane, it would hang diagonally and be extremely awkward to set in place accurately. Furthermore, the blocks with U-shaped holes are frequently euthyteria

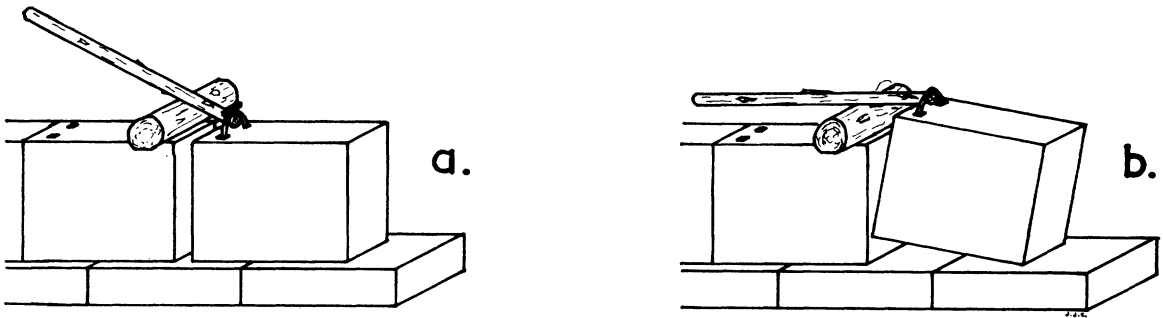

FIG. 2a-b.—Block with U-shaped hole adjusted into position with a lever.

or orthostate blocks, that is, blocks which would need little or no lifting to reach the required level. A more likely explanation of the cuttings in such cases is that the loop of rope through the hole was attached not to a crane but to a wooden lever. A lever used as suggested in FIGURE 2 would be of assistance in moving a heavy block tight up against its neighbour and adjusting its position accurately.<sup>11</sup> Where, in a series of blocks with one cutting each, a few are found to have two cuttings, as in the temple of Hera at Olympia,<sup>12</sup> it seems more likely that both ends of those blocks had to be manoeuvred, or that the first hole was cut in the wrong end, rather than that those blocks alone were set in place by a crane.

Not all surviving blocks with U-shaped holes can be explained in this way, however. Apart from the wall blocks mentioned above, several cornice blocks have U-shaped holes.<sup>13</sup>

<sup>8</sup> For lists of the buildings where U-shaped holes occur see Orlandos 165–8, Martin 210 n. 2. Correct the reference in both for the cornice of the Peisistratid temple at Athens to T. Wiegand, *Die Archaische Porosarchitektur der Akropolis zu Athen* (1904) 121, where the further reference should read F. C. Penrose, *Principles of Athenian Architecture* (2nd ed., 1888) pl. 46. Add to the lists: the early temple of Apollo at Kyrene (L. Pernier, *Il Tempio e l'Altare di Apollo a Cirene* (1935) 54, fig. 27–8, pl. 4); an archaic capital from the Akropolis at Athens (J. Durm, *Die Baukunst der Griechen* (3rd ed., 1910) 98, fig. 71); the early temple of Aphaia at Aigina (A. Furtwaengler, *Aegina* (1906) 140, fig. 113); a cornice and tympanon block from Kalydon (E. Dyggve, *Das Laphrion von Kalydon* (1948) 110–15, 117–18).

<sup>9</sup> U-shaped holes in these positions in ordinary wall blocks are shown by Orlandos (fig. 119.12) followed by Martin (fig. 88), and by Dinsmoor (fig. 63) respectively. The difficulty was noticed by

E. Bourget in *BCH* 36 (1912) 650.

<sup>10</sup> In the Heraion at Olympia, the early temples of Apollo and Athena at Delphi, the Treasury of the Corinthians at Delphi (*BCH* 36 (1912) 650, fig. 3), the early temple of Apollo at Kyrene and the temple of Artemis at Kerkyra. For references see Orlandos 168, Martin 210, n. 2 and above, note 8.

<sup>11</sup> This function was later fulfilled by small slots cut to take an iron crow-bar (Orlandos 129–30, fig. 70, Martin 235–6, figs. 110–11).

<sup>12</sup> E. Curtius, F. Adler, *Olympia, Architecture* (1892) pl. 18.

<sup>13</sup> Treasury of the Corinthians at Delphi, early temple of Aphaia at Aigina, early temple at Mykenai, Peisistratid temple at Athens (F. C. Penrose, *Principles of Athenian Architecture* (2nd ed. 1888) pl. 46), West Building at the Argive Heraion, Kalydon (unattributed). For references see Orlandos 168, Martin 210, n. 2, and above note 8.

The holes are not in the same position in each block, and they do not come close to the end, as in the instances described above. But they do not occur over, or on each side of, the centre of gravity of the block either, so that although it is hard to explain how they *were* used, it seems unlikely that they were used in connection with a crane. In the remaining cases the U-shaped holes are placed so that they *could* be used for lifting. Three column drums from the early temple of Athena Pronaia and one from the early temple of Apollo at Delphi have two U-shaped holes on the upper face and most of the capitals of the temple of Athena have a similar pair.<sup>14</sup> But whether these blocks would need a crane to lift them is not so certain. The drums and capitals of the temple of Athena would only weigh about 300 kg, and could be raised by four men using a pole passed through two loops of rope attached to the U-shaped holes,<sup>15</sup> as shown in FIGURE 3. The drum from the temple of Apollo would be rather heavier (about 900 kg), but might still be raised and manoeuvred by means of a beam used as a lever rather than by a crane.

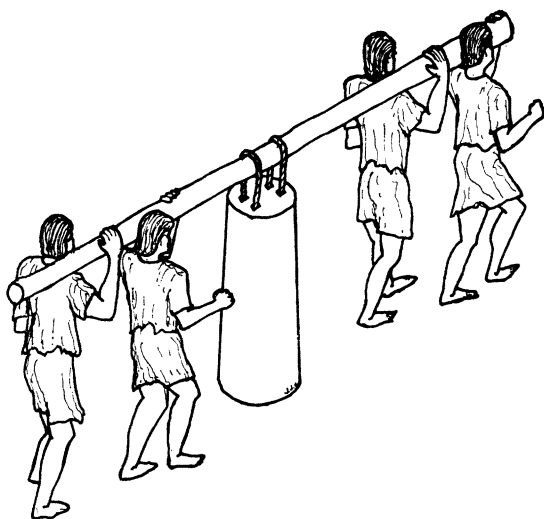

FIG. 3.—Column drum from the early temple of Athena at Delphi hung from a pole carried by four men.

A clearer instance of U-shaped holes used for direct lifting is found in the Treasury of the Athenians at Delphi.<sup>16</sup> The architrave blocks and their backers both have their upper, inner part cut back strongly, so that the two rows of blocks together form a U-shaped beam. From the top surface of each block two holes have been cut down so as to come out in this central channel (FIG. 4a), and it is widely believed that the purpose of these holes was to allow an architrave block and its associated backer to be lifted up and set in place in one operation.<sup>17</sup> As FIGURE 4b shows, however, this explanation is not satisfactory; for since the upper inner part is cut away along the whole length of each block, the architrave and

<sup>14</sup> *FD*, R. Demangel, G. Daux, *Le Sanctuaire d'Athéna Pronaia I* (1923) 29–33.

<sup>15</sup> For this method of carrying heavy stones see E. Naville, *Bubastis* (1891) pl. 30, and *cf.* [Aristotle], *Mech.* 29 (=857b9–20). A. P. Usher, *A History of Mechanical Invention* (2nd ed., 1954) 157, gives the load carried by a man as 90 lb = 41 kg, but that is for a full day. According to J. Smith, *The Panorama of Science and Art I* (1815) 344, a porter used then to carry 180 lb = 82 kg on his shoulder, while a coal-heaver would carry up to 250 lb = 113 kg over a short distance; Hero takes as the standard power input for his *baroukos* a man who can lift 5 talents =

c. 130 kg (Hero, *Mech.* 1.1 (ed. Nix-Schmidt 4, lines 3–5)). Four men could therefore carry 450 kg or so by means of poles. The approximate weights given here and elsewhere in this paper are based on a weight of 2½ tons/m<sup>3</sup> for limestone and 2¼ tons/m<sup>3</sup> for marble.

<sup>16</sup> *FD*, J. Audiat, *Le Trésor des Athéniens* (1933) 34, 52.

<sup>17</sup> *FD*, J. Audiat, *Le Trésor des Athéniens* (1933) 52, followed by Orlandos 168 and Martin 210 n. 3. *FD*, J. Audiat, *op. cit.*, pl. R shows, however, no hole in the southern front architrave block to match the hole near the north end of its backer.

its backer would slide together if they were lifted in one operation (risking damage to the blocks), and when they were set down again on the capitals, they would be some distance apart. On the other hand, the centre of the rectangle formed by the original section of each block (before the upper inner part was cut away) comes directly under the neck of stone left within the U-shaped hole, so that the blocks would hang almost horizontal if they were raised separately by this means (FIG. 4c).

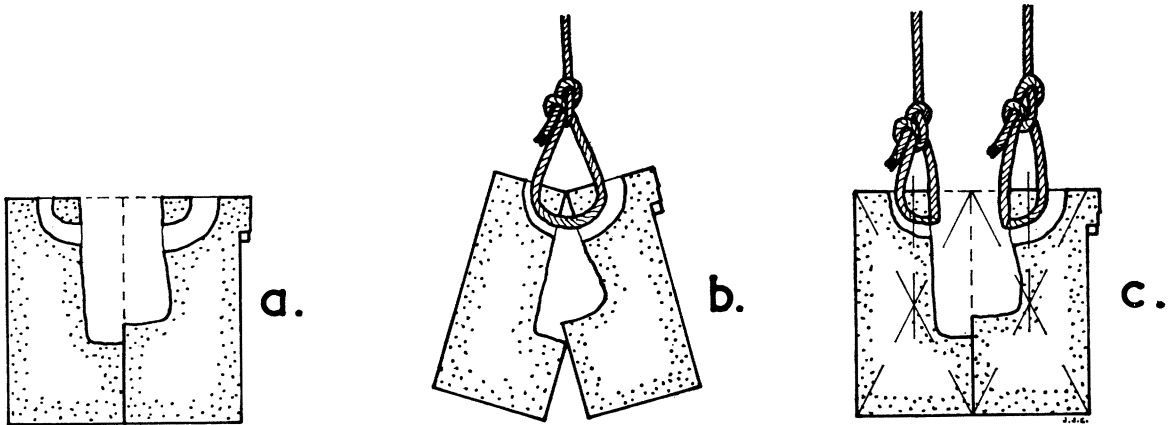

FIG. 4a.—Treasury of the Athenians at Delphi; section of the architrave.  
 4b.—Front and backer blocks of the same architrave lifted together.  
 4c.—Front and backer blocks of the same architrave lifted separately.

The position of the pair of holes in each of the architraves and backers of the Treasury of the Athenians at Delphi, equidistant from the centre of gravity of the block but too far from the ends to be used with a lever as in FIGURE 2, suggests that this time the U-shaped holes *were* used with a crane or hoist, and there is other evidence for that method of lifting in the same building. This is also true of the temple of Aphaia at Aigina, so that the single U-shaped holes in the top its capitals were probably also used with a crane or hoist.<sup>18</sup>

Another feature of Greek architecture which has been widely associated with the use of hoists is the presence of projecting bosses, sometimes called *ancones*,<sup>19</sup> on the faces of wall blocks or on the sides of column drums when these have been left in an unfinished state. It is believed that loops of rope passed round these bosses were used to suspend the blocks or drums concerned from a crane or hoist.<sup>20</sup> The use of such bosses certainly goes back at least to c. 600 B.C., for they occur on the lower courses of the South Stoa at Didyma; they are also found on the archaic temple of Artemis at Ephesos.<sup>21</sup>

Here again, however, much of the evidence argues not for, but against the use of cranes with these bosses. First, although there are exceptions, the normal shape of the bosses is a truncated pyramid (FIG. 5a) rather than an undercut projection suitable for holding a

<sup>18</sup> A. Furtwaengler, *Aegina* (1906) 50, pl. 36. Widespread use of a crane or hoist is virtually certain from the late sixth century B.C. onwards; see below pp. 7–8.

<sup>19</sup> There seems to be no ancient authority for calling these bosses *ancones*.

<sup>20</sup> Orlandos 163–5, fig. 119.1–2; Martin 209–10, fig. 86; W. H. Plommer, *Ancient and Classical Architecture* (1956) 150, 154. W. B. Dinsmoor prefers lifting tongs to loops of rope (Dinsmoor 173); the first argument used here does not then apply, but

the second and third do, and the fourth applies with increased force. Earlier writers were more cautious about the purpose of the bosses: A. Choisy, *L'Art de Bâtir chez les Romains* (1873) 111; G. Perrot, C. Chipiez, *Histoire de l'Art* 7 (1898) 334, 519, KP 225, J. Durm, *Die Baukunst der Griechen* (3rd ed., 1910) 147 etc.

<sup>21</sup> *Ist. Mitt.* 13/14 (1963–4) 32, fig. 5–7; D. G. Hogarth, *British Museum: Excavations at Ephesos; the Archaic Artemisia* (1908) 257, fig. 67.

loop of rope (FIG. 5b). Often, too, the projection is quite insufficient to hold a rope.<sup>22</sup> In the famous unfinished eastern wall of the Propylaea at Athens, for instance, some bosses project an adequate amount, but others which do not seem to have suffered later damage are impossibly shallow. Yet presumably all the blocks of this wall were raised by the same means; if some of the blocks have bosses too shallow for use with loops of rope and a crane, then the bosses on the wall as a whole were not intended for use with loops of rope and a crane.



FIG. 5.—Shape and position of projecting bosses:  
a. typical example as found. b. hypothetical example suitable for use with a loop of rope.

A second objection arises from the existence of blocks with bosses set at the corners of a course, as in the temples at Assos and Segesta.<sup>23</sup> For if a block is to be lifted by loops of rope round bosses, it must have bosses on two opposite sides; in a corner block, any pair of opposite faces will include a joint face, so that if a corner block is to be lifted by loops round bosses, at least one joint face must have been totally unprepared when the block was set, and the joint face must then have been worked *in situ*. Yet what we know of Greek architectural procedure indicates that the joint faces were at least partly worked before the block was set.<sup>24</sup>

Thirdly, it has often been observed that the last block to be set in any course of a building has cuttings for a lewis iron or for lifting-tongs. This was probably because the normal wall blocks were simply lifted up to the correct course by a device placed against the mid-point of the wall and then manoeuvred into place on rollers,<sup>25</sup> but the last block had to be lowered directly into place from above.<sup>26</sup> But if the normal wall blocks were lifted by means of ropes passed round projecting bosses, there would be no need for special cuttings on the last block set, for it too could be lowered into place by ropes round its projecting bosses.

Finally, if a block is to be lifted by loops of rope passed round two bosses, these bosses should be set as high up as possible on the appropriate face of the block, so that the point of suspension is higher than the centre of gravity of the block. Normally the boss is in the middle of the face of a block, so that the supposed point of suspension, the lower side of the boss, is only slightly lower than the centre of gravity, probably not enough to cause any difficulty. But where the block is taller than usual, the boss is no longer placed at the centre

<sup>22</sup> Good examples of bosses with unsuitable shape or inadequate projection can be seen in Orlandos fig. 113, Martin pl. 14.2, 16.2, 17.1-2, 18.1, 27.1, 31.2, 36.2, 52.2. One set of bosses which perhaps project enough to hold loops of rope is on the drums prepared for the earlier Parthenon (*JDAI* 55 (1940) 242-261); some of the knobs are undercut as if to prevent a loop of rope from slipping (as drum 32, *ibid.* 257 fig. 9), but even here there appear to be some inadequate bosses (as on drum 44 (*ibid.* 248, fig. 2)). Many, but not all, of the krepis blocks of the temple at Segesta have strongly projecting bosses, but on these see below and notes 23-4.

<sup>23</sup> KP pl. 19; J. Bacon, F. Clark, R. Koldewey,

*Investigations at Assos 1881-3* (1902-21) 141. Bosses also occur on corner blocks of the Propylaea at Athens and the temple of Zeus at Stratos.

<sup>24</sup> Martin 193-4. This objection in fact applies to most of the krepis blocks of the temples at Assos and Segesta, since there is a row of backing blocks tight up against the facing blocks.

<sup>25</sup> For such a use of rollers, see Hero, *Mechanica* 3.2.

<sup>26</sup> Orlandos 171, fig. 125-6, Martin 215-16, 235. Work was usually begun at the two ends of a wall so that two teams of masons could be supplied by a single lifting device set up opposite the middle of the wall. Cf. also below pp. 6-7.

of the face; but instead of being raised, it is lowered so as to be only a short distance above the lower edge of the block.<sup>27</sup> It would be dangerous to lift a block by ropes round bosses in this position, even if the bosses were suitably shaped. The most outstanding example of bosses set well below the centre of gravity of a block are to be found in the door jambs of the two great temples on Naxos and Paros.<sup>28</sup> In both cases each jamb, about six metres high, has one boss on each face, set about 0.35 m from the foot of the jamb. This is an absurd position if it was intended to lift the jambs by loops of rope round the bosses; yet the shape of the bosses shows that they were intended to resist an upward force from below.

The answer must surely be that these bosses were intended for use not with loops of rope but with a lever. This would certainly explain the position and shape of the bosses at Naxos and Paros, which would have been used not to raise the jambs bodily but to manoeuvre them into position once they had been erected. It would also suit the nature and position of the other occurrences of projecting bosses. If a crane was used to lift wall blocks, it probably did so by means of a rope passed right round the block, which was then set down at the appropriate level on rollers, for transport to its final position. But once there it would need to be raised slightly so that the rollers could be removed; a wooden lever acting under a projecting boss would allow this to be done, and could also be used to adjust the position of the block.<sup>29</sup> Although those bosses which are set well below the centre of gravity of a block must have been planned for use with the block placed the right way up, the projecting bosses would also provide useful purchase for levers in the other handling operations which a block underwent—getting it on and off rollers to be moved around the site, and turning it over so that all six sides could be worked on.

It may also be worth noting that projecting bosses never occur on architrave, frieze or cornice blocks, which would be the most likely to need lifting with a hoist or crane so that projecting bosses were not strictly needed for that purpose. Instead the bosses are found on foundation, krepis and wall blocks, and less commonly on column drums; in the first two positions virtually no lifting would be needed, so that the use of a crane is improbable. For cranes and hoists in Greece and Rome were very much lifting devices only, not used, like a modern crane, to move loads for a considerable distance horizontally as well. With the monokolos (with a single timber forming the jib) some motion in any direction was possible by adjusting the supporting guy ropes,<sup>30</sup> but the scope for movement was obviously limited, for Hero says that it may well be necessary to use rollers to get a block to its final position.<sup>31</sup> The dikolos (with a jib of two timbers) could only move its load back and forth, while the trikolos and tetrakolos (with a supporting frame of three and four timbers) could not move the load horizontally at all.<sup>32</sup> The existence of this limitation is confirmed by the habit we have already noted of building each course from the ends to the centre;<sup>33</sup> for in this way a single crane could deliver blocks for two teams working at each end of the wall

<sup>27</sup> The bosses are set low on the orthostates of the temple of Nemesis at Rhamnous (*BCH* 48 (1924) 312, fig. 4), the Mausoleum at Belevi (Martin pl. 17.1), and in several instances on the Propylaea at Athens (*AJA* 8 (1904) 43, fig. 2), the temple of Apollo at Didyma (T. Wiegand, *Didyma* 1 (1941) pl. 89, 136), and elsewhere.

<sup>28</sup> Naxos: *AM* 49 (1924) 17–22; *AA* 1968, 693–717; *AA* 1970, 144–52. Paros: *AA* 1923–4, 278–94; *AM* 49 (1924) 22–5; *AA* 1970, 144–52. A similar situation occurs in the outer column shafts of the Tower of the Winds at Athens. Being monolithic, they were fluted before being set in place, and a small boss was left in four of the flutes, a few centimetres from the ground, to allow the shaft to be positioned exactly (J. Durm, *Die Baukunst der Griechen* (3rd ed.,

1910) 157, fig. 131).

<sup>29</sup> For the difficulty of removing rollers from beneath a heavy block, see *AA* 1968, 703, n. 8. It is noteworthy that no bosses occur on walls with a quarry-faced outer face (e.g. Martin pl. 42–3). Since it is hard to believe that a series of bosses could have been dressed off such a surface without leaving a trace, there is reason to suppose that the rough quarry face took the place of the bosses. This it could do if the bosses were intended to provide purchase for crowbars, but not if the bosses were intended to take loops of rope.

<sup>30</sup> Vitruvius 10.2.10; Hero, *Mechanica* 3.2.

<sup>31</sup> Hero, *Mechanica* 3.3.

<sup>32</sup> Hero, *Mechanica* 3.4–5.

<sup>33</sup> See above p. 5 and note 26.

simply by lifting them from the foot of the wall to the centre of the appropriate course; if the crane could deliver blocks to any point in the course, it would be as easy to work from the centre to the ends.

If neither the U-shaped hole nor the projecting boss can be accepted as positive evidence for the use of a crane or hoist, is there any other trace on Greek architecture that can? To the present author it seems reasonable that evidence for the use of lifting tongs and the lewis iron should be taken as the positive evidence required.<sup>34</sup> For both instruments imply the suspension of the load from a rope, and while it is theoretically conceivable that the rope should be attached to one end of a long beam, so that the load would be lifted like water in a shadouf, this would provide no mechanical advantage, and can hardly have been used for heavy blocks in practice. Luckily both the lifting tongs and the lewis iron require distinctive holes to be cut in the blocks they are used to lift. Where these occur in Greek architecture, they are either above (or nearly above) the centre of gravity of the block, or in pairs equidistant from a point over the centre of gravity, just as we should expect.

Cuttings for both lifting tongs and lewis irons are first found in Greek architecture in buildings of the late sixth century B.C.<sup>35</sup> Both types of cutting occur in the Treasury of the Athenians at Delphi, the Treasury of the Megarians at Olympia and the Old Propylaea at Athens. Lewis irons were used in the Alkmaionid temple of Apollo at Delphi, the porch added to the Treasury of the Geloans at Olympia, the temple of Aphaia at Aigina and the West Building at the Argive Heraion. All these buildings date from the late sixth or early fifth century; none need be earlier than c. 515 B.C. Thereafter both lifting tongs and lewis irons become common, and we may suppose that the use of a crane or hoist, with or without these devices, became normal practice. It is still of course possible that the crane was used without a compound pulley system, and that it relied simply on plentiful manpower to raise a heavy load; references to pulleys (in the plural) in fourth century inscriptions<sup>36</sup> would then refer to duplication or triplication of a simple pulley system to avoid strain on ropes, etc., and to allow the use of more men. But a crane of this type would offer no mechanical advantage, and it is hard to see why it should have been adopted in preference to other systems of lifting.

Another type of cutting which becomes widespread in Greek architecture at about this time is the U-shaped channel (not to be confused with the U-shaped hole discussed above),<sup>37</sup> which is often found in the same buildings as the cuttings for the lifting tongs or lewis iron—for instance in the temple of Aphaia at Aigina. Since U-shaped channels almost always occur at both ends of a block, not one end only,<sup>38</sup> they too can reasonably be associated with the use of a crane or hoist.

After c. 515 B.C., therefore, the situation seems fairly clear; cranes were in common use. But positive evidence suggesting the use of a crane before that date is scanty. We have already noted pairs of U-shaped holes in the early temples of Apollo and Athena at Delphi which could be used with a hoist, but since another explanation is possible, and since other

<sup>34</sup> Cf. A. Choisy, *L'Art de Bâtir chez les Romains* (1873) 117–18.

<sup>35</sup> For lists of examples with references see Orlandos 170–2, 172–5, Martin 215–16, 218–19. The West Building at the Argive Heraion should be omitted from Martin's list for lifting tongs (Martin 215), for the relevant cuttings are U-shaped holes (*Hesperia* 21 (1952) 245, fig. 10). It has recently been argued that the blocks in which these cuttings occur do not belong to the West Building (*AJA* 77 (1973) 11–16); they must nevertheless date from the sixth century.

<sup>36</sup> See note 6 above.

<sup>37</sup> See FIG. 1. The lists of examples given by Orlandos 169 and Martin 210, n. 4 confuse the two types of cutting. Except for a block attributed to the Treasury of the Sikyonians (see below and note 39), the early buildings at Delphi have U-shaped holes, not U-shaped channels, and should be omitted from the lists. The broad, shallow grooves in the concealed long face of each of the architrave backers of Temple GT at Selinous (KP 125) may have been used to adjust them against the outer blocks by means of a lever. The backers weigh c. 40 tons and the cuttings imply a single point of suspension.

<sup>38</sup> There are some exceptions (KP 225).



U-shaped holes were definitely not used with a crane, we cannot place much confidence there. A U-shaped channel in a block attributed to the early Treasury of the Sikyonians at Delphi may perhaps be regarded as a variant of the U-shaped hole in this instance, intended for manoeuvring rather than lifting the block.<sup>39</sup>

Other possible evidence comes from Selinous, where some architrave blocks of Temple C have cuttings at each end which are interpreted as sockets to take wooden or metal cross-pieces for the attachment of lifting ropes. There are some difficulties in this explanation; for instance, the difficulty of removing the lifting ropes once the architrave block was set in place on the capital. It is also worth noting that not all the architrave blocks have cuttings of any sort,<sup>40</sup> and that the simplest way of lifting an architrave of this type into place with a crane would be to pass two ropes right round it at points which, when the block was in place, would be just beyond the abacus of the capital.<sup>41</sup>

In addition to these cuttings in some architrave blocks, some of the cornice blocks of Temple C have unusual cuttings. Two grooves were cut along the bottom face and both joint faces of these blocks,<sup>42</sup> and may have been used to take a loop of rope running right round the block. It is less certain that this loop of rope was attached to a crane; since some only of the blocks are involved, it could be that the loop of rope was used with levers to manoeuvre a block between two blocks already in position. If the rope was smaller than the groove, it could be withdrawn once the block was in place by untying the knot in it. Pairs of parallel grooves are also found on blocks from the ends of the pronaos walls of Temple D at Selinous,<sup>43</sup> and on the wall-blocks of the much earlier (mid-seventh century?) temples at Corinth and the Isthmian sanctuary.<sup>44</sup> Here again a crane is a possible, but not a necessary explanation; it is worth noting that the blocks concerned in the last three buildings are very light; the pronaos blocks from Temple D weigh less than 400 kg, while the wall blocks from Corinth weigh only about 260 kg.

The two substantial cases where there appears to be evidence of lifting by crane in an early building are the temple of Athena at Assos and the first temple of Hera ('Basilica') at Paestum. At Assos there are U-shaped channels at each end of some cornice blocks, while others have unusual cuttings which are interpreted as sockets to take iron hooks attached to a hoist.<sup>45</sup> At Paestum the frieze backers of the first temple of Hera also have U-shaped channels at each end.<sup>46</sup>

<sup>39</sup> *FD*, R. Demangel, G. Daux, *Le Sanctuaire d'Athéna Pronaia* 1 (1923) fig. 36. The building is not fully published, and it is unclear how firmly the block is attributed and whether there was a similar cutting at its other end.

<sup>40</sup> KP 99 record three different types of cutting, of which that referred to here is the most complex; it occurs on 3 blocks of the 12 listed by KP. The other types, occurring on 4 of the 12 blocks, have no rope groove, and so would not allow a block to be set tight against its neighbour. The remaining 5 blocks have no cutting.

<sup>41</sup> This was done with the front architrave blocks of the temple of Poseidon at Sounion; the backers there had to be lifted with lewis irons so as to be set tight up against the front blocks (Orlandos 163, 170; for a less likely method, see *BSA* 45 (1950) 85), but in Temple C at Selinous the main part of the architrave consists of just a single row of blocks.

<sup>42</sup> KP 105, 225, illustrated by J. Durm, *Die Baukunst der Griechen* (3rd ed., 1910) fig. 237. These cornice blocks are attributed to Temple D by Orlandos 169, followed by Martin 212-13, but

KP 105 refer to Durm's illustration (in the second edition (1892) of *Die Baukunst der Griechen*, 117, fig. 89) in their description of Temple C, and they make no mention of such grooves in the cornice of Temple D. Only two or three of the cornice blocks have these cuttings, and KP 225 suggest they may have been among the last laid blocks in the course.

<sup>43</sup> KP 107, fig. 85.

<sup>44</sup> *Hesperia* 24 (1955) 153-7 (Corinth); O. Broneer, *Isthmia* 1 (1971) 13. M. C. Roebuck (*Hesperia* 24 (1955) 156) comments on the lightness of the blocks from Corinth, and suggests that the rope loops were used for the general handling of the blocks, not specifically for lifting.

<sup>45</sup> J. Bacon, F. Clark, R. Koldewey, *Investigations at Assos 1881-3* (1902-21) 155, fig. 6; Orlandos 169, fig. 122. Orlandos refers also to lewis holes in this temple (Orlandos 173, fig. 127), but they occur only in the ceiling beams attributed to the temple by Clark, but justly rejected by Bacon and Koldewey (*Investigations at Assos* 166-7).

<sup>46</sup> KP 17. I owe this observation to W. H. Plommer.

If we wish to get rid of these 'exceptions', we must suppose either that the U-shaped channels and other cuttings were in these cases used with levers rather than with cranes; or that these two temples are considerably later than is often thought; or that the temples were indeed begun early, but that they were under construction for a long time and that the blocks suggesting the use of a crane were not set until after *c.* 515 B.C. The first way out is rather an unfair argument; the second is perhaps possible, since there is no concrete evidence for the date of either temple and some scholars have suggested that the temple at Assos belongs to the late sixth century B.C.;<sup>47</sup> but the third seems the most reasonable. At Assos the cornice would of course be the latest main element of the exterior, and although the alternating sizes of its mutules may seem an early feature, it is one which derives necessarily from the sizes of the triglyphs and metopes, which in turn must have been defined by the time the architrave was put in place—perhaps long before the cornice. At Paestum a firm *terminus ante quem* for work on the first temple of Hera must be the start of the second temple of Hera ('Poseidon') in the mid-fifth century. It is uncertain how long before that the frieze backers were set in place.<sup>48</sup>

It may be, however, that none of these explanations is required, and that we should rather take the evidence from Assos and Paestum at its face value, as indicating that cranes were already used by Greek builders in the third or even the second quarter of the sixth century B.C. A decision on this point must await the conclusion of the argument. If in the meantime, however, the temples at Assos and Paestum are left aside, it appears that there is nothing to compel belief in the use of cranes in Greek architecture before *c.* 515 B.C., and the scantiness of the evidence that can be taken as suggesting it in itself indicates that the use of a crane cannot have been common practice. We are simply faced with the fact that heavy blocks were raised to the required level by *some* means. The question of how this was done can perhaps be more usefully looked at from the other end. Instead of seeing how far the classical Greek methods can be traced back, let us consider how the Greeks may have learnt to handle heavy weights, and how far the methods they are likely to have adopted initially can be traced forward.

In Greece itself the problem of lifting heavy loads did not seriously arise before the second quarter of the seventh century B.C. Before that date there was no monumental sculpture and the stones used in building were not normally larger than could be lifted by two men,<sup>49</sup> so that there was no need for any special techniques. In about the middle of the seventh century the Greeks began to produce both sculpture and architecture involving large pieces of stone, and since statues were normally set on bases, they too, like architectural blocks would need to be raised to the required height. Temple A at Prinias (*c.* 630 B.C.?) provides one of the earliest examples of large stone blocks in both architecture and sculpture, the largest frieze block weighing about half a ton.<sup>50</sup> The architrave blocks of the temple of Artemis at Kerkyra (*c.* 590–80) would have weighed 5 or 6 tons,<sup>51</sup> but such loads seem insignificant beside the Colossos of the Naxians at Delos, which must have weighed over

<sup>47</sup> So A. W. Lawrence, *Greek Architecture* (1957) 119. D. S. Robertson, *Greek and Roman Architecture* (2nd ed., 1945) 84, 325 had suggested *c.* 560 B.C. and W. B. Dinsmoor (*Dinsmoor* 88) *c.* 540 B.C. The early date is supported by W. H. Plommer in *BSA* 65 (1970) 186 n. 9.

<sup>48</sup> The roof terra-cottas of the temple (*MonAnt* 43 (1956) 303–9) must be later than its frieze-backers, but are hard to date. They are similar in type to those of the 'Tavole Palatine' at Metapontum (*ibid.* 309–14), which is usually dated in the late sixth century.

<sup>49</sup> Cf. H. Drerup, *Griechische Baukunst in geometri-*

*scher Zeit* (*Arch. Hom. Kap. O*, 1969) 106. Where larger stones were used, they occur in positions where they could be levered into place with crowbars, without actual lifting; cf. A. Cambitoglou *et al.*, *Zagora* 1 (1971) 22–3, n. 7.

<sup>50</sup> For the dimensions of the block see *Annuario* 1 (1914) 53. Larger blocks weighing *c.* 1.7 tons were used in the mid-seventh century fortifications at Leontinoi (F. G. Winter, *Greek Fortifications* (1971) 128–9).

<sup>51</sup> The intercolumniation was probably 3.07 m, the architrave width *c.* 1.20 m, its height unknown. If we follow the reconstruction proposed by H.

20 tons itself,<sup>52</sup> and stood on a base weighing over 30 tons. So within little more than 50 years the Greeks had learnt to handle blocks more than 100 times heavier than those they had been used to previously. It is unlikely that their efforts were undertaken in complete isolation from the rest of the world and that in this short time they invented a completely new way of dealing with heavy weights.

Large stone blocks were used to some extent in the architecture of the Levant and Assyria, but most commonly for orthostates, thresholds and column bases, all positions where the blocks would not have to be raised to any extent.<sup>53</sup> It is true that the first evidence for the use of the pulley comes from an Assyrian relief,<sup>54</sup> but it shows just a simple pulley used to haul up a bucket of water. There is no evidence that the system was further developed, and if not, it would not be suitable for the kind of loads we are dealing with. A series of reliefs from the palace of Sennacherib (705–681 B.C.) shows the various stages in the transportation and setting up of a colossal winged bull, which must be imagined as weighing 40–50 tons; and the job is done with levers, a sledge and rollers, and an artificial ramp.<sup>55</sup> It is hardly surprising that no crane is used, for it is doubtful, as we shall see, whether a simple crane could lift such a weight; but there is no sign of a block and tackle or a winch, both of which would be useful in hauling such a load. Neither here, nor in the colossal statues actually preserved do the Assyrians show any desire to piece a colossus together from smaller blocks of stone that could be handled by a crane, the method adopted for the monument of Antiochos I of Commagene on Nemrud Dagh.<sup>56</sup>

The method used by Sennacherib is exactly that familiar in Egypt, and Egypt was of course the chief home of the arts of large scale sculpture and large scale architecture in stone; it can surely be no coincidence that large scale stone sculpture and architecture began to appear in Greece at precisely the time when close contact with Egypt was resumed.<sup>57</sup> A brief examination shows that although Greek borrowing from Egypt in the field of architectural form was comparatively limited, the technical similarities between Greek and Egyptian architecture are extremely close, covering virtually all aspects from the methods of quarrying stone to the dressing down of the building in the final stages. Among these similarities are two of the features we have already looked at, the U-shaped hole and the projecting boss.<sup>58</sup> They occur more rarely in Pharaonic architecture than in Greece, but the fact that they occur at all confirms the arguments based on the evidence of Greek architecture, that both these devices are to be associated with the use of wooden levers rather than a crane or hoist. For it is virtually certain that Egyptian architects of the third and second millennia B.C. did not use any kind of pulley system.

The method most clearly used by the Egyptians for raising heavy blocks of stone was the

Schleif (G. Rodenwaldt, *Kerkyra* 1 (1940) 33, fig. 92), the main (lower) block, c. 0.70 m high, would weigh c. 6 tons. If, as seems more likely in view of the height of the existing fragment and the position of the U-shaped hole, the architrave consisted of two rows of blocks side by side, each block would weigh about 5½ tons.

<sup>52</sup> The weight of the Sounion kouros can be estimated as c. 2 tons by taking its height as 3.10 m, and its average cross-section as c. 0.40 × 0.60 m. Since the Colossos of Delos was about four times life size (G. M. A. Richter, *Kouroi* (2nd ed., 1960) 51), its height should have been c. 7 m or 2¼ times that of the Sounion kouros; its weight would therefore be (2¼)<sup>3</sup> = c. 11.4 times that of the Sounion kouros, or about 23 tons. It need hardly be said that this is a very approximate estimate, but it may not be an over-estimate, for Cyriac of Ancona, who apparently

saw the Colossos in a much more complete state, seems to give its height as 24 cubits, or 10–11 m (*Archaeology* 25 (1972) 213).

<sup>53</sup> G. Loud, C. B. Altmann, *Khorsabad* 2 (1938) 15.

<sup>54</sup> *JCuneifS* 7 (1953) 5–7, fig. 1.

<sup>55</sup> A. H. Layard, *Nineveh and Babylon* (Abridged; 1867) 18–28.

<sup>56</sup> J. M. Cook, *The Greeks in Ionia and the East* (1962) pl. 49–50.

<sup>57</sup> This has often been argued for sculpture (e.g. G. M. A. Richter, *Kouroi* (2nd ed., 1960) 2) and in general, although not in detail, for Greek architecture (e.g. J. Boardman, *The Greeks Overseas* (1964) 159–60).

<sup>58</sup> S. Clarke, R. Engelbach, *Ancient Egyptian Masonry* (1930) 86. This is still the most useful book on Egyptian building techniques, and the remarks below are based on it.

ramp. A temporary ramp of earth and mud-brick was built against the wall under construction, its height being raised as work progressed, and the stone blocks were hauled up the ramp on rollers and then levered into position. A hypostyle hall would be filled with earth as it was built, so that the architrave blocks could be hauled up the ramp, too.

Besides the ramp, the Egyptians used the lever to some extent, although it is uncertain whether they ever used it to lift a block more than a few centimetres. They may also have used what has been called a rocker; that is, a kind of sledge with runners shaped like segments of a circle so that a block loaded on to it could be rocked backwards and forwards like a rocking-chair. By judiciously placing pieces of wood beneath the runners as the sledge is rocked, it is possible to raise it gradually (FIG. 6). Although rockers of this type

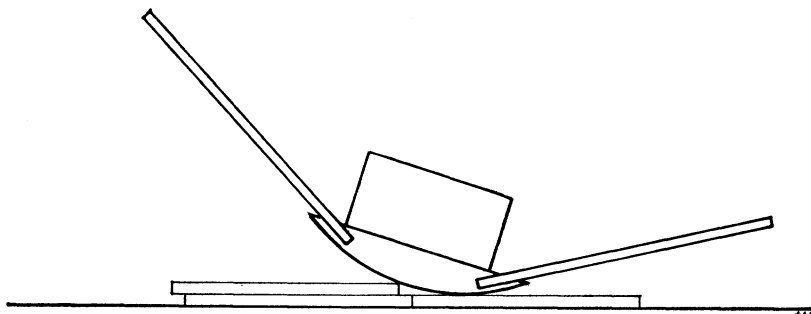

FIG. 6.—Rocker, possibly used for lifting architectural blocks.

were certainly used by Egyptian builders, there is some doubt about whether they were used for lifting.<sup>59</sup> The main positive evidence is in Herodotos' description of the construction of the Pyramid of Cheops, where he says that in the last phase the stones were raised by means of 'a device made with short pieces of wood'.<sup>60</sup> It seems unlikely that this is a fairy story, yet these terms can hardly be applied to a ramp or a lever or a crane. They do suit the rocker technique, however, for in addition to the rocker itself being made out of fairly short pieces of wood, a vital part is played by the short pieces of wood placed beneath the runners, for the feasibility of the system depends on the stability of the platform which they form.

Thus ramps, levers, and perhaps rockers are the lifting devices for heavy loads which the Greeks could have learnt of when they first took to monumental building. We have already seen reason to believe in the use of levers in early Greek architecture, although in Greece, as in Egypt, it is uncertain whether they were ever used for extensive lifting. For the ramp we have the well-known story in Pliny's *Natural History*<sup>61</sup> of how Chersiphron raised the architraves of the temple of Artemis at Ephesos by means of a ramp. This story has been disbelieved, and even where it has not been rejected, it is generally been taken as an unusual departure from normal Greek practice. It probably would have been unusual in the fifth century, but it is much less certain that it was unusual in the sixth century.<sup>62</sup> As we

<sup>59</sup> A model rocker comes from a foundation deposit at Deir el Bahari (E. Naville, *Deir el Bahari* 6 (1908) 9, pl. 168). The use of rockers for lifting is strongly upheld by A. Choisy, *L'Art de Bâtir chez les Egyptiens* (1904) 80-93, but is considered of little importance by S. Clarke, R. Engelbach, *Ancient Egyptian Masonry* (1930) 94.

<sup>60</sup> Herodotos 2.125.

<sup>61</sup> Pliny, *Nat. Hist.* 36.14, 21, 95-6. Pliny and Vitruvius (*De Arch.* 7, pref. 16) confuse the two temples of Artemis at Ephesos. The clearest indication that Chersiphron was connected with the

archaic temple is the similarity of the methods of transport developed by him and his son Metagenes (Vitr. *De Arch.* 10.2.11-12) to those used in the archaic Temples F and G'T at Selinous (*KP* 119-20, 125).

<sup>62</sup> It is the weight not the method of raising it that Pliny remarks on, and it was not the raising of the blocks but setting them in place that caused Chersiphron most anxiety. If the blocks could be raised by a winch-driven crane, setting them would present little difficulty.

shall see, builders in the archaic period, like Egyptian builders, handled and raised blocks of stone much heavier than could be raised with a simple crane or hoist. The architrave blocks of the temple of Artemis must have been among the heavier blocks lifted in the sixth century, but they would not have been in a class of their own.<sup>63</sup> For the use of the rocker in Greek architecture we have no evidence, and short of a direct reference to one it is difficult to imagine what evidence could ever be found. If it was used, it had gone out of use by the time of Herodotos,<sup>64</sup> for it is fairly clear that he does not understand exactly what was the device that the Egyptians had told him about.

Much of the favour with which the hoist based on a compound pulley system is regarded by modern archaeologists is perhaps due to the fact that it is the normal method used today for raising heavy building components. It is doubtful, however, if its advantages were so striking in the sixth century B.C., and it may be worthwhile to compare the two systems from the point of view of a sixth-century builder. As far as mechanical advantage is concerned, the ramp is superior to the compound pulley system, for with the latter a theoretical advantage of 1 : 6, using 6 pulley wheels, is the useful maximum if natural fibre ropes are used, and this is the largest number of pulleys specified by Vitruvius.<sup>65</sup> On the other hand there is evidence of ramps with slopes of 1 : 8 and 1 : 12 in Egypt,<sup>66</sup> giving a corresponding mechanical advantage. In terms of power input, the two systems are comparable if, with the pulley system, the power is applied directly by men pulling a rope;<sup>67</sup> for in both cases the power input can easily be increased by setting more men to pull. But in this case, in addition to offering less mechanical advantage, the pulley system offers less control, for it would be hard to lower a load gently, and there would be no easy way of applying a brake if the men stumbled.<sup>68</sup>

If the compound pulley system is combined with the use of a winch, the mechanical advantage is much increased, perhaps ten times or more; but there is a limit to the amount of power that can be harnessed to a winch with a horizontal axle.<sup>69</sup> It would be easy enough to set two men to work at each end of the winch axle, but hard to increase the number of men efficiently employed much beyond that number. A pair of men working

<sup>63</sup> See the table below (p. 17). I assume that the architrave, which the extant capitals show to have been about 1.05 m. wide, had a height about equal to the lower column diameter, and was made of a single block of marble over each span, giving a weight of about 41 tons for the central front architrave.

<sup>64</sup> It would presumably go out of use on the introduction of the hoist in the late sixth century. Herodotos was born shortly before 480 B.C.

<sup>65</sup> The polyspaston has 6 pulleys in each system (not counting the guide pulley at the base of the jib, of course) Vitr. 10.2.8-9. This practical limitation is naturally disregarded in the theoretical parts of Hero's *Mechanica* (*Mech.* 2.3).

<sup>66</sup> I. E. S. Edwards, *The Pyramids of Egypt* (2nd ed., 1961) 271.

<sup>67</sup> Or animals (Hero, *Mechanica* 3.3). Hero seems to expect that the power will be applied directly like this, but Vitruvius directs it only for one machine (Vitr. 10.2.8-10).

<sup>68</sup> Hence Vitruvius emphasises that only experts can operate the polyspaston, worked by direct pulling without a winch (Vitr. 10.2.8).

<sup>69</sup> In contrast to Hero, Vitruvius clearly regards

a winch as normal. The winch of the trispaston certainly had a horizontal axle (Vitr. 10.2.2), and the terms of his description suggest that the other devices did too. Some modern authorities prefer to show a capstan turning on a vertical axle (e.g. J. Durm, *Die Baukunst der Griechen* (3rd ed., 1910), fig. 68), basing the restoration presumably on the illustration to Hero *Mechanica* 3.2 (Teubner ed. Nix-Schmidt, figs. 47, 76; A. G. Drachmann, *The Mechanical Technology of Greek and Roman Antiquity* (1963), fig. 35). A capstan can have longer bars providing greater mechanical advantage and allowing more men to exert their strength usefully, but it is considerably more difficult to provide effective bearings for a capstan, and also to brace it firmly from the crane, so that winding rope on to the capstan lifts the load rather than uprooting the capstan. The earliest reference to a winch is in Herodotos 7.36, where winches are used to tighten the cables for the bridge across the Hellespont in 480 B.C., but winches may have been used in Assyria from the seventh century B.C. (*JCuneifS* 7 (1953) 15-17). Winch and pulley hoists are regarded as normal for architectural use in [Aristotle], *Mech.* 18 (=853b10-13).

a winch cannot apply a continuous force of more than about 50 kg,<sup>70</sup> so that the power input would be only about 100 kg. A reasonable axle diameter for the winch would be 0.15 m, with handles turning through a circle about 1.50 m in diameter, so giving a mechanical advantage of 1 : 10. If this were used in association with a six-wheel pulley system, and worked by four men, the maximum load would be  $10 \times 6 \times 100 \text{ kg} = 6 \text{ tons}$ . Friction would reduce this maximum in practice, but different dimensions in the winch could increase it somewhat, and of course if two such hoists were used together, they could lift double the load. But it is hard to see how a simple winch and hoist could raise the loads of 20 to 40 tons that were not avoided in the archaic period. To raise very heavy loads, Vitruvius<sup>71</sup> advises either what Drachmann<sup>72</sup> calls a geared winch (which increases the mechanical advantage, so allowing the power input to remain small) or a treadwheel attached to the winch axle (which perhaps increases the mechanical advantage somewhat, but more obviously allows the power input to be substantially increased). By these means weights of 20–30 tons could be lifted,<sup>73</sup> but it seems highly unlikely that the Greeks, beginners in the field, had devised such refinements as these in the mid-sixth century B.C. We shall see that this limit in the lifting capacity of the winch and pulley hoist, in contrast to the unlimited capacity of the ramp, may be of some significance in the argument.<sup>74</sup>

The advantages of the winch and pulley hoist do not lie in its greater efficiency as a means of lifting loads. The most obvious advantage over the ramp is the much smaller amount of preliminary work involved. A hoist may require a good deal of highly skilled labour in its construction,<sup>75</sup> but once made, it can be used repeatedly, and moved from one place to another. The ramp requires a considerable expenditure of effort to reach a height of several metres,<sup>76</sup> and almost the same amount of effort is needed to remove it; and it has to be constructed afresh on each occasion it is required. Another advantage of the hoist is that if the load is within its capacity, then it can be handled by fewer men working over a longer time, and probably with more skill, than the men pulling a block up a ramp on

<sup>70</sup> If each man turns one handle continuously through a full circle, there is a weak point at the top and bottom of the turn which must be arranged to coincide with the strong point of another man's turn. If each man changes his grip from one hand spike to another in the course of the turn, so as to exert his force more effectively, then the load must be held by half the men working the winch while the other half change their grip. Figures given for the force which can be exerted by a man turning a handle vary (see the references quoted in note 15), but seem to be based on the assumption that he is working steadily all day. The figure used here, 50 kg. per pair of men, is based on the assumption that if they are working over a much shorter period and do not have to turn the winch fast, a pair of men can exert at every point in the turn a force nearly equal to the full weight of one man.

<sup>71</sup> Vitruvius 10.2.5–7.

<sup>72</sup> A. G. Drachmann, *The Mechanical Technology of Greek and Roman Antiquity* (1963) 204, cf. 146–7.

<sup>73</sup> A good example is the crane shown in the well-known relief from the Tomb of the Haterii at Rome (Orlandos fig. 50). Taken literally, this shows a crane with five strands of rope hanging from the jib, and so five pulleys; it has a tread wheel with a diameter 12 times its axle diameter, and driven by 7 men. If we assume that each man is able to exert a force of 50 kg on the circumference of the wheel,

the theoretical maximum load of the crane will be  $5 \times 12 \times 7 \times 50 \text{ kg} = 21 \text{ tons}$ . Although this would be substantially reduced by friction, it would be possible to have 6 pulleys instead of 5, a treadwheel diameter more than 12 times the axle diameter, and considerably more than 7 men effectively working the wheel, so that the real lifting capacity could still be of the order of 20 to 30 tons.

<sup>74</sup> The argument to be used below is not invalidated if the specific figures given in this paragraph are not accepted. It is sufficient to accept that there is *some* limit on the power input, and so the lifting capacity, of a winch and pulley hoist.

<sup>75</sup> It is interesting to speculate, but difficult to calculate, how far the expense of constructing a ramp exceeds the expense of building a heavy crane from scratch, given that no lifting device is already available on the site, and that there is at the time no intention of constructing more than one building. We usually assume that the ramp has to be specially built, while the crane is already there.

<sup>76</sup> An important point in the comparison is that the expense of making a ramp of given slope increases at a rate somewhere between the square and the cube of the increase in height. Increasing the height of a crane involves much less rise in the cost, but here again the limit feasible with simple means is reached sooner with a crane than with a ramp.

rollers. Thus the chief difference between the performance of the hoist and the winch is that the former involves more skilled labour working over a longer time, while the latter involves the use of a large body of unskilled labour working perhaps over a shorter time. This characteristic of the ramp was not seen as a disadvantage by the rulers of Egypt and Assyria, who had a plentiful supply of unskilled labour, and it is doubtful whether their builders would have used a compound pulley hoist, even if they had known about it, for it would have placed an unwelcome limit on the size of stone they could employ. But in Greece, particularly by the end of the sixth century, political, social and economic conditions made it difficult to bring together a large body of unskilled labour for a limited period, and it was preferable to use methods which allowed fewer men, but professionals, to work full time.

It will obviously be important, therefore, to examine the weights actually lifted by the Greeks and Romans at various periods, and these are set out, as far as possible, in the accompanying table (p. 17). The weights in column 5 are all based on a calculated volume of stone given in column 3, and since it was in most cases impossible to find the precise weight per cubic metre of the stone involved, the conversion from volume to weight has been worked using standard factors of 2·75 tons/cub. m. for marble (indicated by (M) in column 4) and 2·25 tons/cub. m. for other stone. Blocks of irregular shape have been treated as cuboidal by estimating their average height, length and width;<sup>77</sup> clearly the weights of statues involve more approximation than the weights of architrave blocks. The table is of course selective, but it contains the heaviest blocks that I have been able to find evidence for. The lintel blocks of some temples may have been heavier than the architrave blocks which I have listed, but lintels have rarely survived.

The very rapid growth in the ability to handle heavy weights in the late seventh–early sixth century has already been noted, with the suggestion that this implies a technique learnt from others, not developed in Greece. Almost as striking is the drop in the weights handled during the fifth and much of the fourth century. There were at least thirteen blocks weighing over 20 tons used during the sixth century, and some of those listed as just one do in fact constitute a whole series of blocks, as with the architraves of the temple of Artemis at Ephesos and Temples FS and GT at Selinous or the column shafts of the temples of Apollo at Syracuse and at Corinth. Yet in the fifth century no blocks weighing over twenty tons<sup>78</sup> were used, and only two series, the architrave blocks of the temple of Zeus at Olympia and Temple ER at Selinous, weigh much over 12 tons. The smaller scale of the buildings in the fifth century, and the increasing interest in detail and refinement rather than sheer size, explain this drop in block size to some extent, but there was also a positive effort to keep down the weight of individual blocks.

One aspect of this change is the disappearance at the end of the archaic period of the practice of constructing large column shafts out of a single block. The way in which the Greeks erected such shafts is unknown. Even with a crane it would not be easy, for the minimum lift required would be half the weight of the column shaft. Since in practice the direction of the pull would almost certainly be oblique to the movement of the shaft, a substantially greater force would in fact be needed, in many cases beyond the powers of a simple crane. Here again, however, in view of the early date of some of the largest monolithic shafts, it is likely that the Greeks were using a learned technique, and here again they could easily have learned it from the Egyptians. The Egyptian method was almost certainly based on ramps rather than pulleys, but its exact nature is not known;<sup>79</sup> what we

<sup>77</sup> See for example note 49.

<sup>78</sup> The lost relieving lintel over the central door of the Propylaea had a total volume of 6·3 m<sup>3</sup> and so a weight of *c.* 17 tons, but like the other lintels of the Propylaea it probably consisted of two blocks side by

side, so that each would weigh about 8½ tons.

<sup>79</sup> S. Clarke, R. Engelbach, *Ancient Egyptian Masonry* (1930) 148; *cf.* R. Engelbach, *The Problem of the Obelisks* (1923) 66–79.

do know is that the Egyptians were adept at erecting monolithic obelisks far larger than any monolithic column shaft of the Greeks. The Greeks had used column shafts built up from drums throughout the sixth century, of course, but the exclusive use of drum-built shafts except for very small columns suggests that from the early fifth century onwards, lifting many smaller weights was easier than erecting fewer large ones.

The Parthenon offers another example of positive effort to restrict the weights lifted. The west door lintel was formed by four blocks set side by side,<sup>80</sup> each weighing 9 tons or less; contrast the monolithic lintels at Naxos and Paros weighing over 20 tons. The architrave of the Parthenon consists of three blocks side by side weighing  $9\frac{1}{2}$  tons each, rather than two blocks side by side weighing *c.* 14 tons each; contrast the architrave of temple FS at Selinous (*c.* 525 B.C.), which consisted of a single row of blocks weighing 21 tons each.

The change of attitude is most strikingly illustrated, however, in the Olympieion at Akragas.<sup>81</sup> The whole design of this temple, which was probably begun in the late sixth century B.C., seems to have been governed by the desire to build on a colossal scale without using colossal blocks. U-shaped channels, which, as we have seen, are probably to be associated with the use of a crane or hoist, are found on most, if not all, the entablature blocks, and the heaviest blocks in the building weigh about 14 tons. The contrast with Temple GT at Selinous,<sup>82</sup> begun perhaps 20 or 30 years earlier, is striking; there the architrave blocks weighed about 40 tons each,<sup>83</sup> and some column drums were even heavier.<sup>84</sup> Only the cornice blocks, which belong late in the sequence of construction, have U-shaped channels, and these, like the cornice blocks of the Olympieion, weigh about 12 tons.

It might be argued that other explanations of these facts are possible. Might not the architraves and lintels of the Parthenon have been made as they were because the Pentelic quarries would not yield any larger blocks? Certainly these are the largest blocks in the Parthenon, but they are not the thickest; the capitals and most of the column drums have their smallest dimension greater than half the architrave thickness, so that since blocks long enough and tall enough could obviously be quarried, there is no reason why the extra thickness should not have been obtained to allow the architraves to be made out of two rows of blocks. Several centuries later the Pentelic quarries yielded longer, taller, thicker blocks for the architraves of the Olympieion at Athens, and the corner architraves there consist of only two blocks, weighing up to 23 tons each.<sup>85</sup> Again it might be supposed that the unusual construction of the Olympieion at Akragas resulted not from problems with lifting, but from the weakness of Akragantine stone, which would not allow construction in the normal way, as at Selinous. Although that might explain the existence of the screen wall and the form of the architrave, however, it does not explain why the half-columns were built up from small blocks; for if there were doubts about the reliability of the stone, it would be safer to build them of drums in the usual way. Moreover there is a general objection to arguments of this kind. If archaic builders in a large number of different areas

<sup>80</sup> N. Balanos, *Les Monuments de l'Acropole, Relèvement et Conservation* (1938) 85, Parthenon folding plate 1. F. C. Penrose, *The Principles of Athenian Architecture* (2nd ed., 1888) pl. 16 wrongly shows the lintel formed of three blocks.

<sup>81</sup> KP 121-7.

<sup>82</sup> KP 154-66.

<sup>83</sup> The architraves may have been set no earlier than those of the Olympieion at Akragas, but the crucial stage was the decision to build a colossal temple on conventional lines, a decision which must have been taken in about 530-20 B.C., probably before cranes were exploited in architecture. Once a temple of this type was begun, there was no way of

avoiding the huge architrave blocks, even though they demanded procedures which, by the time they were set in place, might seem old-fashioned.

<sup>84</sup> The lines indicating drum divisions in the restored elevation of the temple (KP 126, fig. 105) may not be absolutely accurate, but the photograph (*ibid.*, fig. 107) suggests that they are roughly correct; in that case some of the drums used weighed over 50 tons.

<sup>85</sup> F. C. Penrose, *The Principles of Athenian Architecture* (2nd ed., 1888) 37-8. Penrose (*ibid.* 18) notes that the marble is coarser-grained than in Periklean buildings: but it is still no doubt Pentelic.



could obtain structurally sound blocks weighing 20 to 40 tons when they wanted them, it seems unlikely that no quarry exploited during the fifth or fourth century B.C. would yield them.

It is therefore hard to avoid the conclusion that the builders of the fifth century B.C. felt themselves bound by some limitation in the lifting of heavy weights which had not been felt by sixth century builders. It is only with the rebuilding of the colossal Ionic temples in Asia Minor, from the mid-fourth century onwards, that the weights lifted grow again to match those lifted in the archaic period, and by that time there is no reason why the more sophisticated types of winch described by Vitruvius should not have been developed. Nevertheless, the columns of the temple of Apollo at Didyma are built up from quite low drums, and the architrave (which was not in fact set until the Roman period) consists of two rows of blocks side by side, the heavier of them weighing just over twenty tons each.<sup>86</sup> The feeling that unlimited lifting power was available comes only in the Imperial period, with its fashion for monolithic column shafts.<sup>87</sup> The temple of Jupiter at Baalbek demonstrates this clearly. The great trilithon, a triad of blocks in the podium weighing about 500 tons each, is well known; but really more striking is the way in which, far from dividing the architrave as at Didyma, the builders have cut both the architrave and the frieze for each intercolumniation from a single block, the weights ranging up to 60 tons,<sup>88</sup> and high up in the northwest corner of the west pediment they set an even larger block, weighing over 100 tons.<sup>89</sup>

*Conclusion.* The assumption that Greek builders used a crane of some sort from the very beginning of the sixth century B.C. seems to be unfounded. Two technical features of Greek architecture which have been taken as evidence for the crane, the U-shaped hole and the projecting boss, are rather to be associated with the use of levers, and both appear to have been adopted from Egypt, where pulleys and cranes were unknown.

At this point we must pick up the argument left unfinished on p. 9. We saw there that there was clear and widespread evidence for the use of cranes in Greek architecture from c. 515 B.C. onwards, but that there are only two buildings seeming to provide substantial evidence for the use of cranes before that date—the temple of Athena at Assos and the first temple of Hera at Paestum. There are two main ways of explaining this state of affairs. Either the crane was indeed used by Greek builders from the mid-sixth century B.C. onwards, but only occasionally until the late sixth century, when the invention of the lewis iron and lifting-tongs made its use more convenient—or perhaps just more obvious to us. Or else the crane was in fact not used in architecture before c. 515 B.C., and the apparent exceptions must be accounted for in one of the ways suggested on p. 9.

If the first explanation is right, it is odd that the only clear evidence of cranes before 515 B.C. should come from such outlying cities as Assos and Paestum. But much the strongest reason for preferring the second explanation—in spite of the seeming impropriety of wishing away inconvenient exceptions—comes from a consideration of the weights lifted. At just the same time as the first evidence for lewis irons and lifting-tongs, we find a conscious and positive preference for the use of several smaller blocks of stone rather than fewer large ones. There are no more blocks weighing over 20 tons, and the practice of using monolithic shafts is abandoned except for very small columns. These changes imply some fairly radical change in building technique, something more than just the invention of lewis irons and lifting-tongs. However, if the compound pulley hoist was in fact not introduced before c. 515 B.C., that would account not only for the first occurrence of lewis- and lifting-

<sup>86</sup> T. Wiegand, *Didyma* I (1941) 98–9, pl. 63.

<sup>87</sup> Those of the Basilica Nova, listed here, seem to have been the heaviest at Rome, but the monolithic shafts of the Pantheon, the temple of Antoninus and Faustina, the temple of Saturn, the Baths of Caracalla

and Diocletian all seem to have weighed between 30 and 50 tons.

<sup>88</sup> T. Wiegand, *Baalbek* I (1921) pl. 23.

<sup>89</sup> *Ibid.*, fig. 30.

tong-cuttings (and the widespread use of U-shaped channels) but also for the simultaneous drop in the weight of the largest blocks lifted. For there is a definite limit to the size of load that can be lifted by a simple winch-driven compound pulley hoist.

In any case the large blocks used by archaic builders would be too heavy for such a crane or hoist, and must have been lifted by means of ramps, levers and massed manpower, following the methods already well-known in Egypt and Assyria. The increase in the size of blocks lifted in the Hellenistic period, and particularly under the Roman Empire, is probably due not to a reversion to the use of ramps, but to the development of more sophisticated cranes, such as those described by Vitruvius and illustrated on Roman reliefs.

Since a crane using just a single pulley would offer no advantage over the ramp for the sort of blocks normally used by Greek builders, it is more likely that the idea of the compound pulley system was developed in some other field, perhaps in connection with shipping,<sup>90</sup> where the loads required were more manageable, and where ropes and masts would naturally be available for experiment. Only when this development had taken place would it be feasible to use the hoist for heavy lifting in architecture, so that the late sixth century can probably be taken as a *terminus ante quem* for the invention of the compound pulley hoist. On the other hand, once that development *had* taken place, there would be nothing but conservatism to keep the hoist out of Greek architecture, so that we may conclude most reasonably, although not with certainty, that the compound pulley system was invented in the second half, perhaps in the last quarter of the sixth century B.C. Thus practice preceded theoretical discussion by more than 200 years.<sup>91</sup>

J. J. COULTON

*University of Edinburgh*

<sup>90</sup> The yard arms of Dionysos' boat on the cup by Exekias are each controlled by a rope passing from the stern through a loop at the yard arm and back to the stern again (L. Casson, *Ships and Seamanship in the Ancient World* (1971) 69–70). No pulley is shown at the yard arm, but the helmsman hauling on one end of the rope, the other being fixed, would gain some mechanical advantage. The principle is the same as in a compound pulley hoist, and once noticed, the same principle could easily have been used in loading and unloading cargo, with pulleys introduced to

reduce friction. But there is no evidence whether that was in fact done in the sixth century B.C. By the first century B.C., of course, a block and tackle was certainly used for handling cargo (Vitruvius 10.2.10).

<sup>91</sup> I am greatly indebted to Dr W. H. Plommer for his detailed and helpful criticisms of a draft of this paper. He has enabled me to tighten up the argument in many places, and the weaknesses that remain are there in spite of, rather than because of, his advice.

TABLE OF WEIGHTS IN GREEK ARCHITECTURE AND SCULPTURE

| date    |   | m <sup>3</sup> | tons                |
|---------|---|----------------|---------------------|
| c. 650  | Nikandre Dedication                                   | 0.1 (M)        | $\frac{1}{4}$       |
| c. 640  | Temple of Poseidon at Isthmia<br>wall blocks          | 0.21           | $\frac{1}{2}$       |
| c. 650  | Fortification wall at Leontinoi                       | 0.77           | $1\frac{3}{4}$      |
| c. 630  | Prinias frieze slab                                   | 0.225          | $\frac{1}{2}$       |
| 610–590 | Sounion kouros  | c. 0.7 (M)     | c. 2                |
| 610–590 | Naxian colossos at Delos<br>base                      | 12.5 (M)       | 34                  |
|         | figure  | c. 8 (M)       | c. 23               |
| 590–80  | Temple of Artemis at Kerkyra<br>central pediment slab | 1.42           | $3\frac{1}{4}$      |
|         | architrave block                                      | 2.2 or 2.7     | 5 or $6\frac{1}{4}$ |

| date       |  | m <sup>3</sup> | tons                 |
|------------|--|----------------|----------------------|
| c. 565     | Temple of Apollo at Syracuse                       |                |                      |
|            | stylobate block                                    | 10.8           | 24                   |
|            | column shaft                                       | 15.7           | 35                   |
|            | architrave block                                   | 9.1            | 20 $\frac{1}{4}$     |
| c. 555     | Olympieion at Syracuse                             |                |                      |
|            | stylobate block                                    | 9.2            | 20 $\frac{1}{4}$     |
| 560-50     | Temple of Artemis at Ephesos                       |                |                      |
|            | central architrave                                 | c. 15?         | (M) 41 $\frac{1}{4}$ |
| 550-30     | Selinous, Temple C                                 |                |                      |
|            | stylobate block                                    | 5.6            | 12 $\frac{1}{2}$     |
|            | architrave block                                   | 7.1            | 16                   |
| c. 540     | Temple of Apollo at Corinth                        |                |                      |
|            | column shaft                                       | 11.5           | 26                   |
|            | architrave block                                   | 4.5            | 10                   |
| c. 535     | Selinous, Temple D                                 |                |                      |
|            | architrave block                                   | 6.1            | 13 $\frac{3}{4}$     |
| c. 525     | Selinous, Temple FS                                |                |                      |
|            | architrave block                                   | 9.3            | 21                   |
| c. 520     | Colossos at Apollona, Naxos                        | c. 25          | (M) c. 69            |
| c. 520     | Temple of Apollo, Naxos                            |                |                      |
|            | lintel   | 7.9            | (M) 22               |
|            | threshold  | 8.1            | (M) 22 $\frac{1}{4}$ |
| c. 520     | Temple at Parikia, Paros                           |                |                      |
|            | lintel   | c. 8           | (M) c. 22            |
| c. 515     | Olympieion at Athens                               |                |                      |
|            | column drum  | 4.0            | 9                    |
| c. 520-409 | Selinous, Temple of Apollo ('GT')                  |                |                      |
|            | column drum in quarry                              | 32.5           | 73                   |
|            | architrave block                                   | 17.5           | 40                   |
|            | cornice block                                      | 5.5            | 12 $\frac{1}{2}$     |
| c. 500-406 | Olympieion at Akragas                              |                |                      |
|            | central abacus block                               | 5.7            | 11 $\frac{1}{2}$     |
|            | architrave blocks                                  | 4.1            | 9 $\frac{1}{4}$      |
|            |  | 4.9            | 11                   |
|            |  | 6.2            | 14                   |
|            | lower metope block (angle)                         | 6.0            | 13 $\frac{1}{2}$     |
|            | cornice block                                      | 5.1            | 11 $\frac{1}{2}$     |
| c. 500     | Temple of Aphaia at Aigina                         |                |                      |
|            | column shaft                                       | 2.7            | 6                    |
| 480-60     | Selinous, Temple ER                                |                |                      |
|            | architrave block                                   | 7.6            | 17                   |
| 468-57     | Temple of Zeus at Olympia                          |                |                      |
|            | stylobate block                                    | 3.8            | 8 $\frac{1}{2}$      |
|            | architrave block                                   | 7.4            | 16 $\frac{1}{2}$     |
| c. 460     | Temple of 'Poseidon' at Paestum                    |                |                      |
|            | architrave block                                   | 5.1            | 11 $\frac{1}{2}$     |
| 448-37     | Parthenon at Athens                                |                |                      |
|            | architrave block                                   | 3.5            | (M) 9 $\frac{1}{2}$  |
|            | largest lintel block                               | 3.28           | (M) 9                |
| 437-32     | Propylaia at Athens                                |                |                      |
|            | central architrave block                           | 4.53           | (M) 12 $\frac{1}{2}$ |
|            | largest lintel block                               | 4.5            | (M) 12 $\frac{1}{4}$ |
|            | relieving lintel (if in two blocks <sup>92</sup> ) | 3.15           | (M) 8 $\frac{3}{4}$  |
|            | west porch ceiling beam                            | 3.6            | (M) 10               |

<sup>92</sup> See note 78.

## LIFTING IN EARLY GREEK ARCHITECTURE

19

| date                         |   | m <sup>3</sup> | tons |
|------------------------------|---|----------------|------|
| 421-05                       | Erechtheion at Athens                         |                |      |
|                              | block over Pandroseion                        | 4.2 (M)        | 11½  |
|                              | north door lintel                             | 2.66 (M)       | 7¼   |
|                              | north porch ceiling beam                      | 3.6 (M)        | 10   |
| c. 420                       | Temple at Segesta                             |                |      |
|                              | architrave block                              | 5.5            | 12½  |
| 366-26                       | Temple of Apollo at Delphi                    |                |      |
|                              | architrave block                              | 4.1            | 9¼   |
| c. 340                       | Temple of Zeus at Nemea                       |                |      |
|                              | architrave block                              | 3.0            | 6¾   |
|                              | lintel block                                  | 3.9            | 8¾   |
| c. 310                       | Temple of Apollo at Didyma                    |                |      |
|                              | threshold                                     | 17 (M)         | 46¾  |
|                              | lintel (if monolithic)                        | 17.5? (M)      | 48   |
|                              | jamb (if monolithic)                          | 26 (M)         | 71½  |
| (Second century<br>A.D.?)    | architrave block                              | 7.5 (M)        | 20½  |
| c. 170 B.C.                  | Olympieion at Athens                          |                |      |
|                              | largest architrave block                      | 8.5 (M)        | 23¼  |
| First century<br>B.C.        | New base for Apollo statue<br>(Vitr. 10.2.13) | 18.5 (M?)      | 51?  |
| First-second<br>century A.D. | Temple of Jupiter at Baalbek                  |                |      |
|                              | block in quarry                               |                | 1500 |
|                              | largest of trilithon                          | 260            | 580  |
|                              | lower column drum                             | 21.5           | 48½  |
|                              | central architrave-frieze block               | 28             | 63   |
|                              | corner cornice block                          | 48             | 108  |
| A.D. 306-13                  | Basilica Nova at Rome                         |                |      |
|                              | column shaft                                  | 37.4 (M)       | 103  |
| A.D. 530                     | Tomb of Theodoric at Ravenna                  |                |      |
|                              | roof slab                                     |                | 470  |