

ΑΡΧΙ- ΤΕΚΤΩΝ
ΤΕΚΤΩΝ

ΤΕΥΧΩ

ΠΡΙΣΙΣ - SAW





A Large Stone Quarry from the End of the Second Temple Period Discovered in Jerusalem
Photo: Assaf Peretz, courtesy of the Israel Antiquities Authority

MARBLE QUARRY, WEDGES

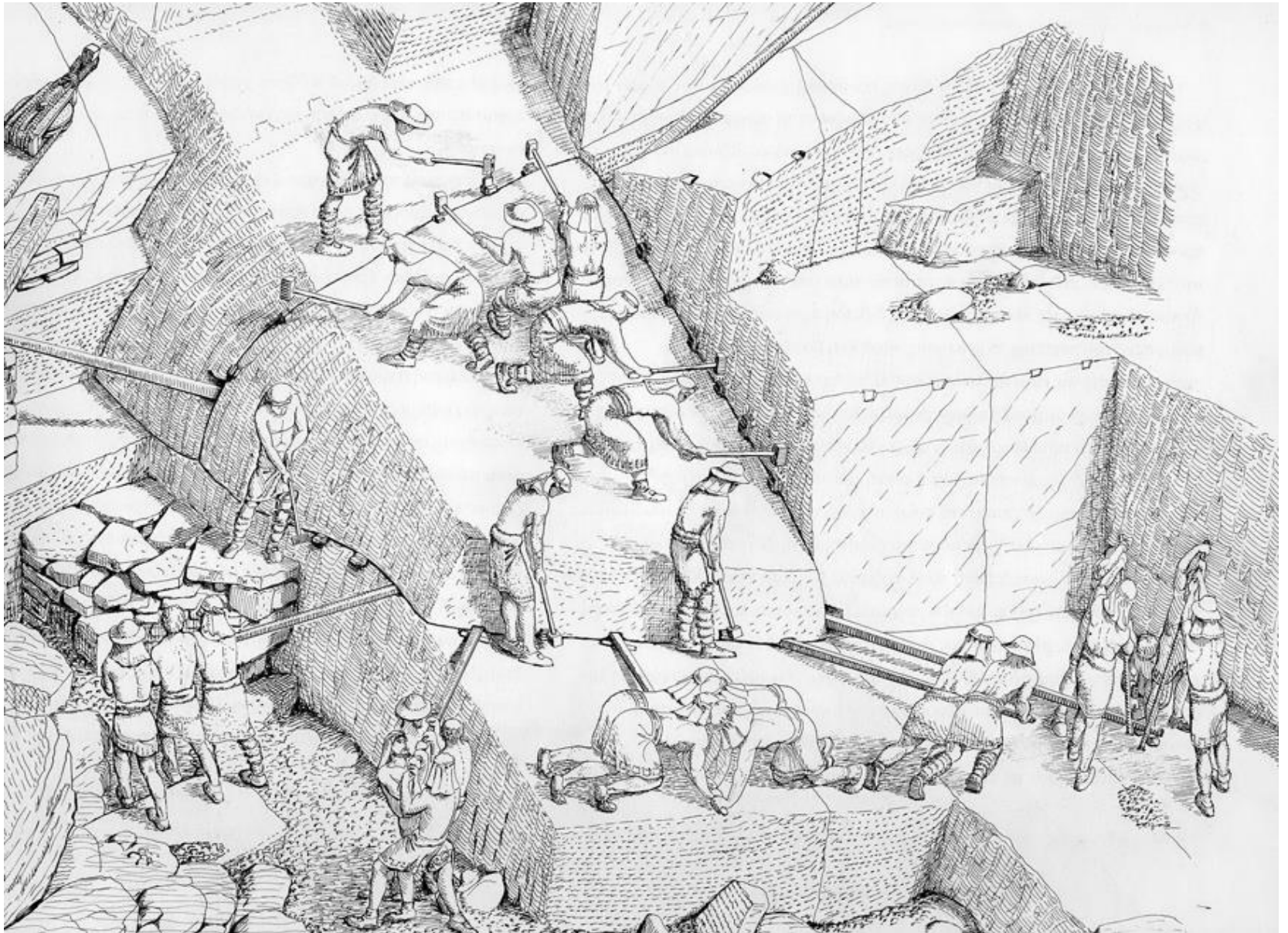



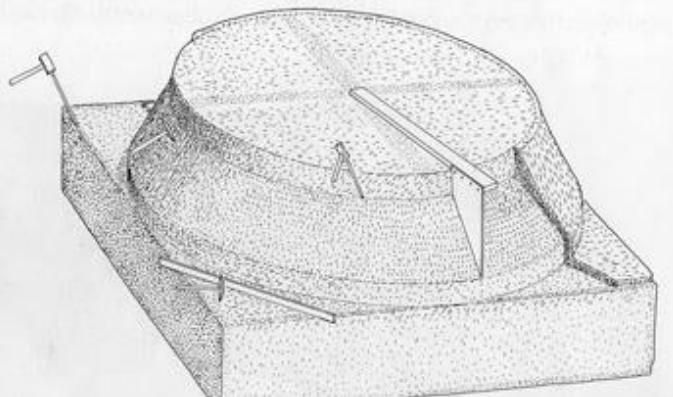
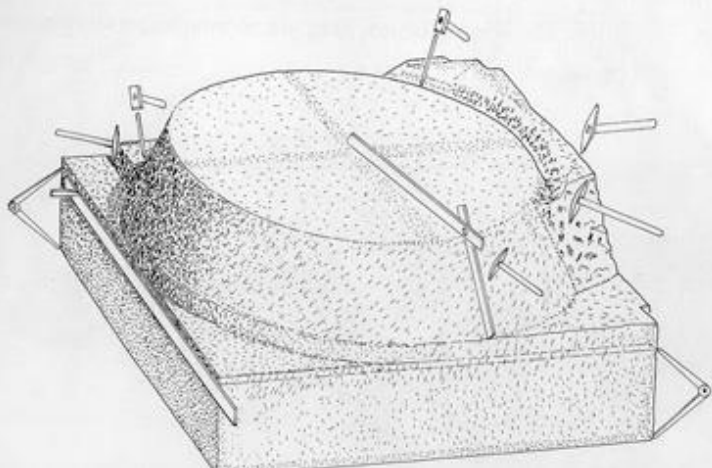
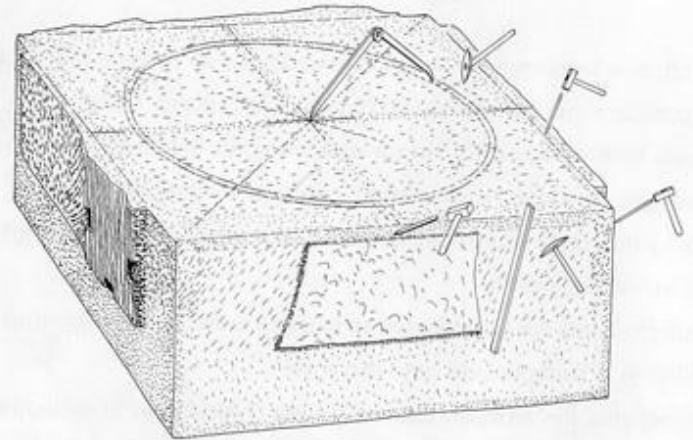
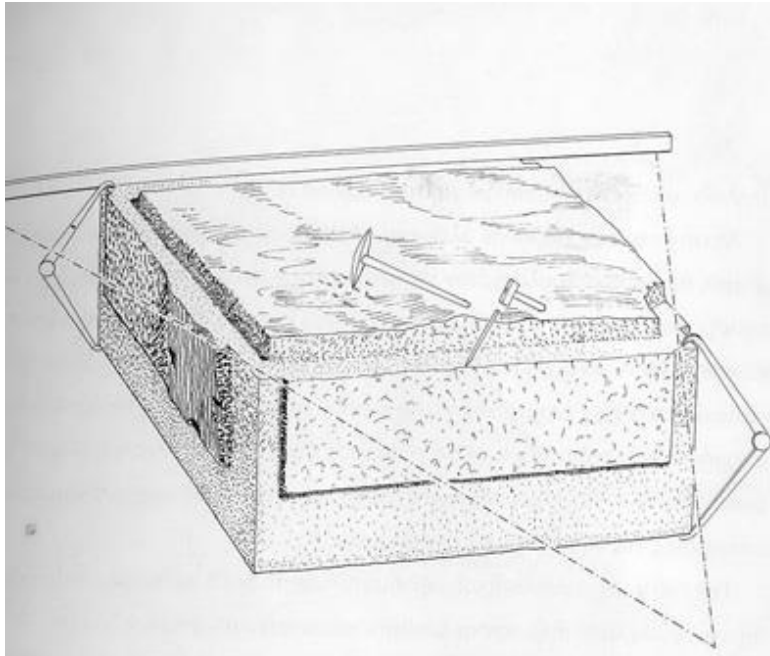

TRANSPORTATION DEVICES

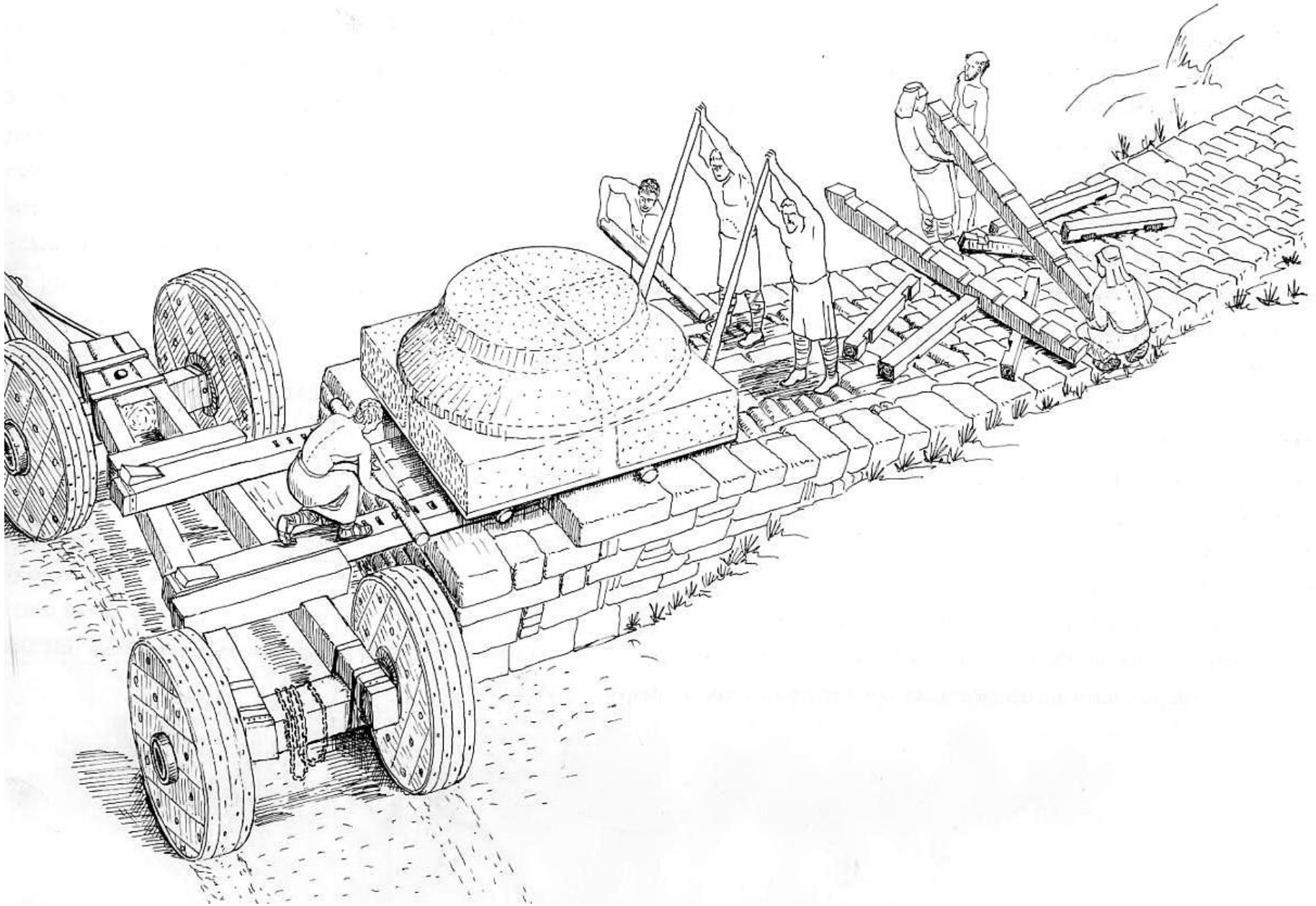

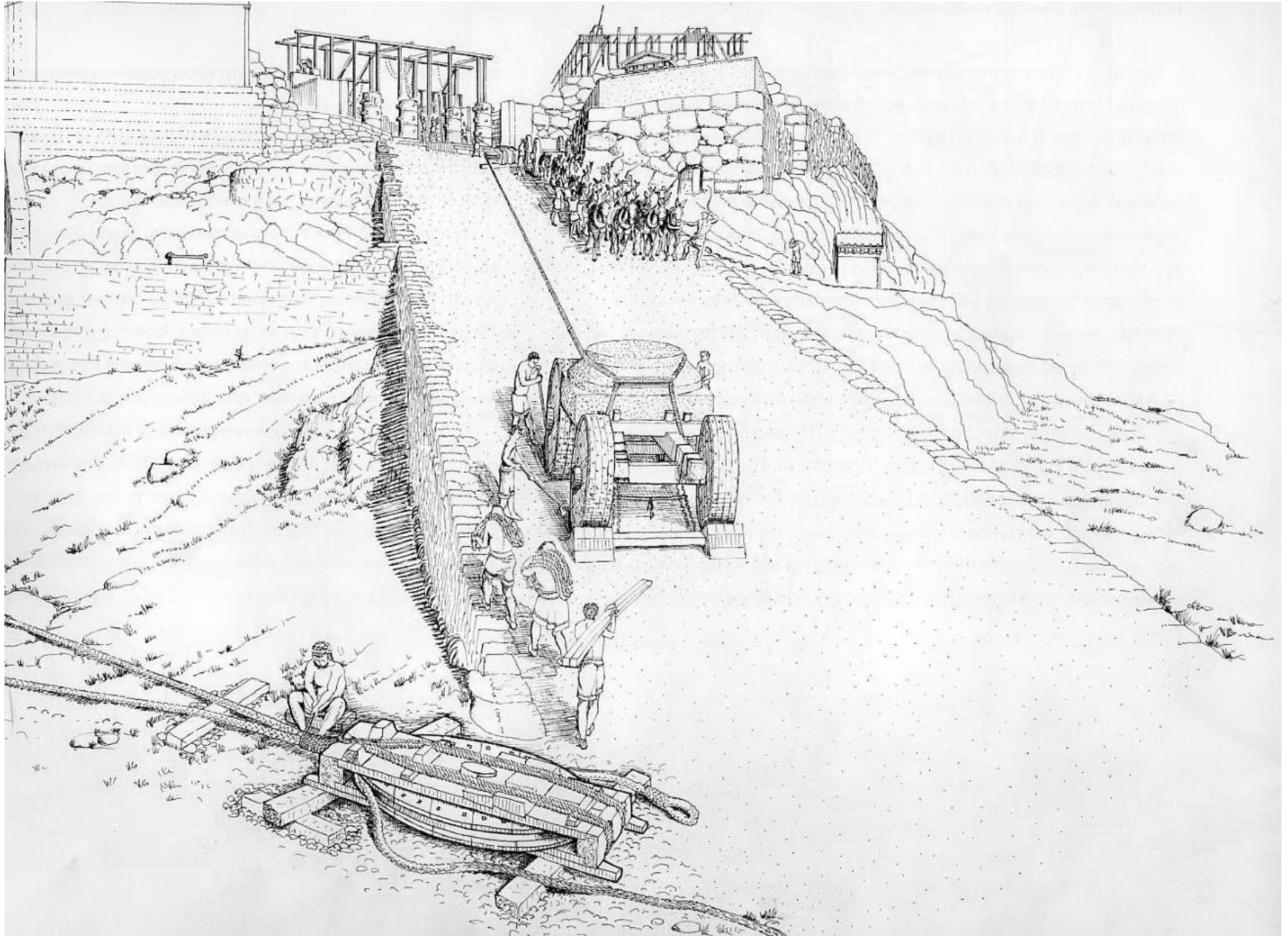





www.shutterstock.com · 51433042



www.shutterstock.com · 69293155





ABANDONED BLOCK IN BAALBEK



ABANDONED COLUMN
SHAFES IN A QUARRY
AT CARYSTOS



ABANDONED STATUE IN A MARBLE QUARRY, NAXOS



ABANDONED STATUE IN A MARBLE QUARRY, NAXOS



LIFTING DEVICES BEFORE THE INVENTION OF A CRANE



STONEHENGE BUILDER: THE LITHO LIFT

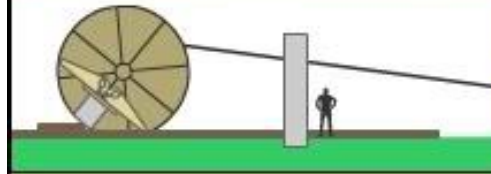

Engineer Nick Weegenaar believes a wooden wheel mechanism similar to his 'Litho Lift' may have been used.

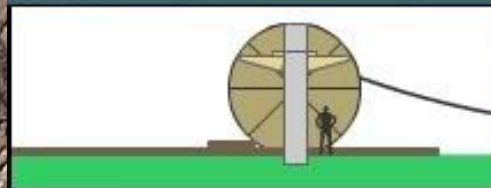
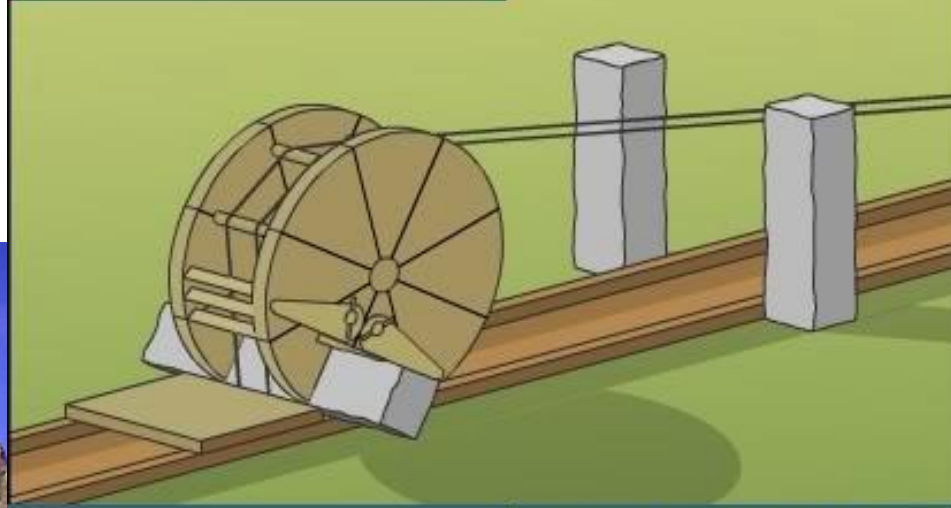

The lintel rolls in the wheel until it is above the uprights, before being lowered down. A track guides the wheel and counterweights act as ballast.

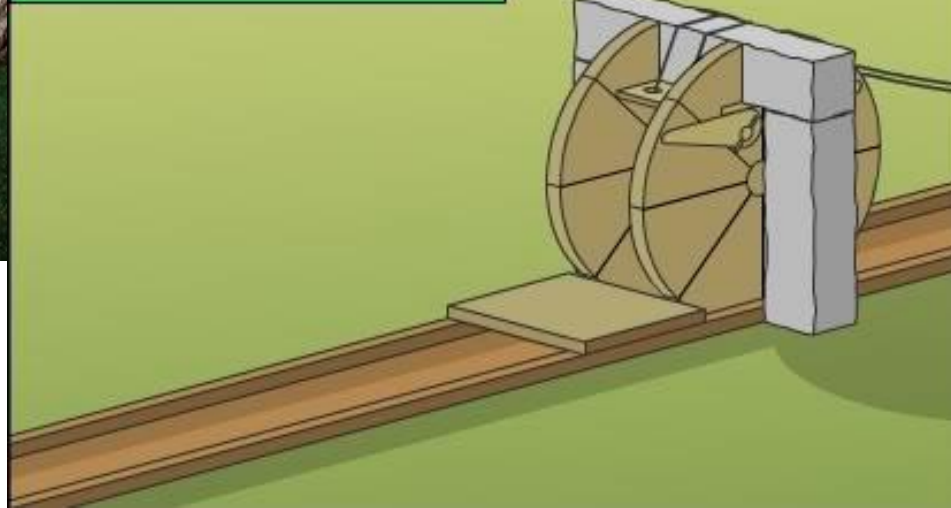

- THE GIANTS ON THE EASTER ISLAND







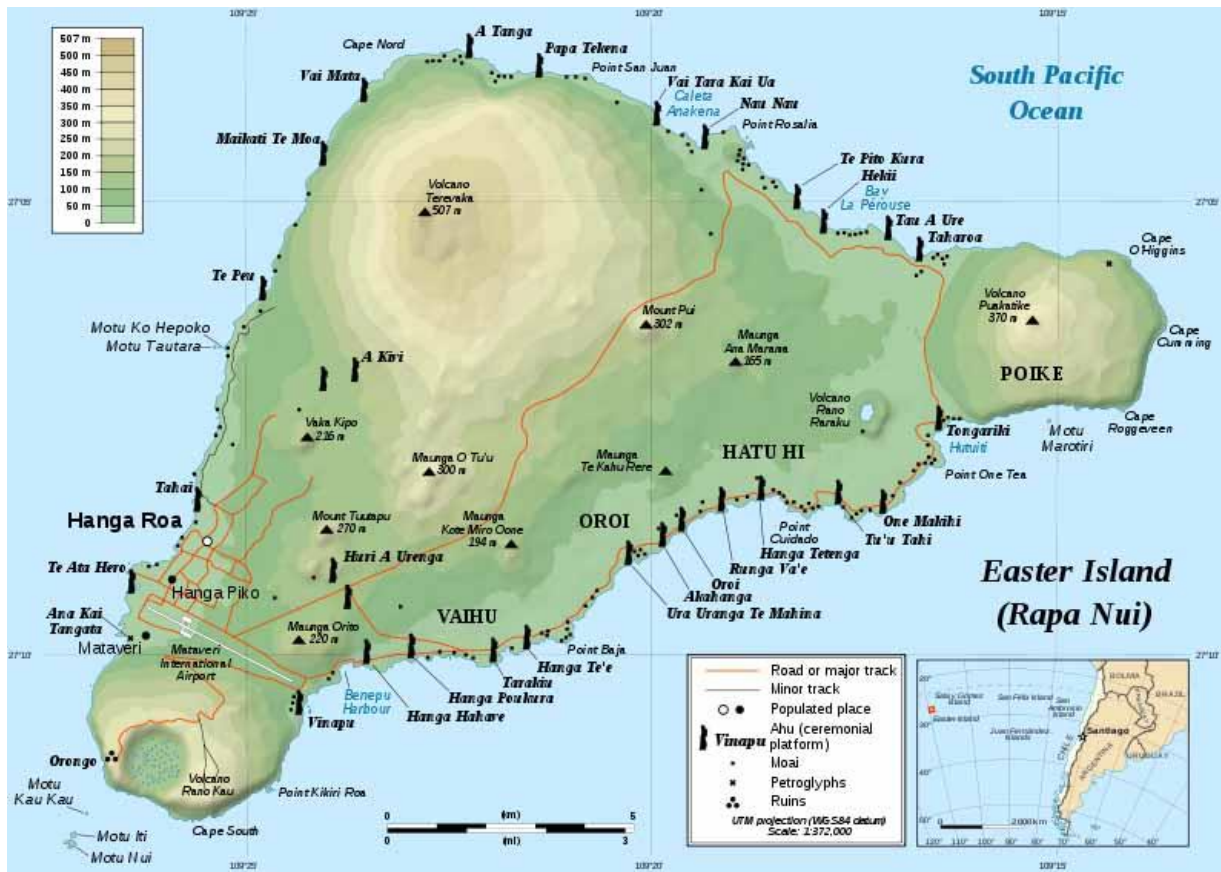

THE GIANTS WERE FORCED TO WALK



«LOW FAITH IN HUMAN»

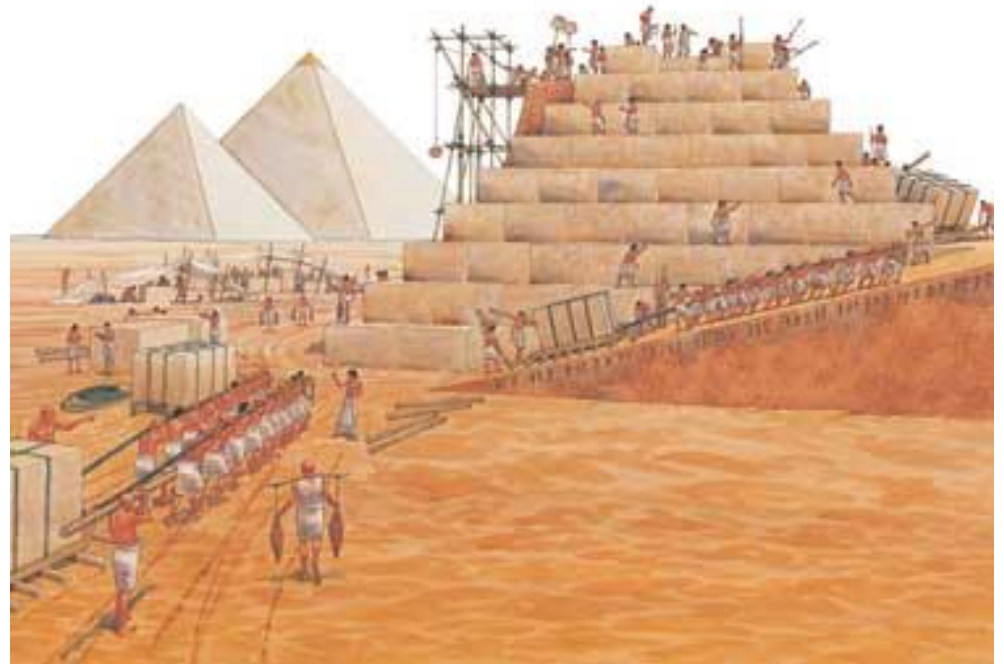
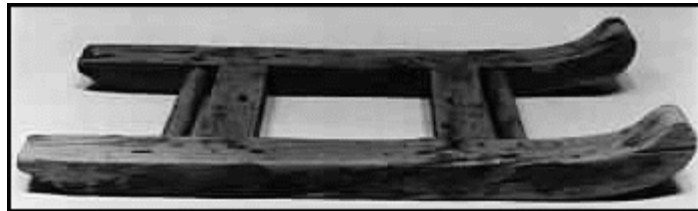

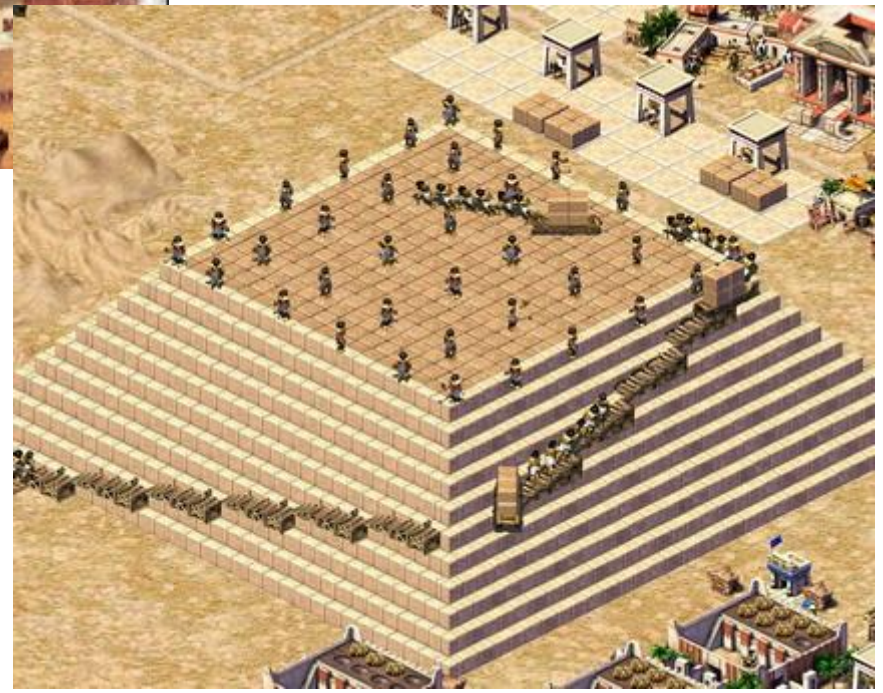
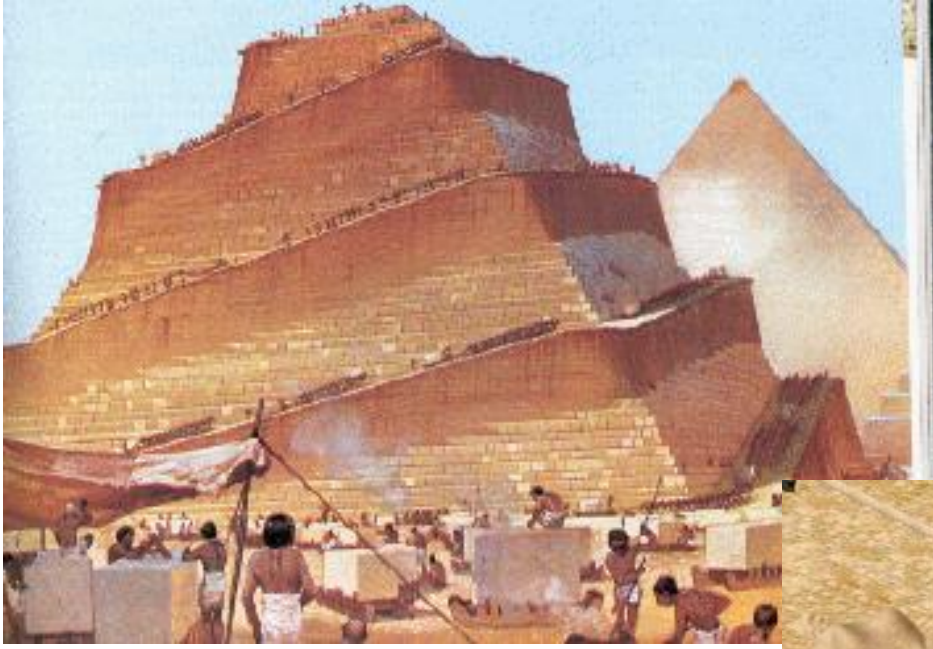

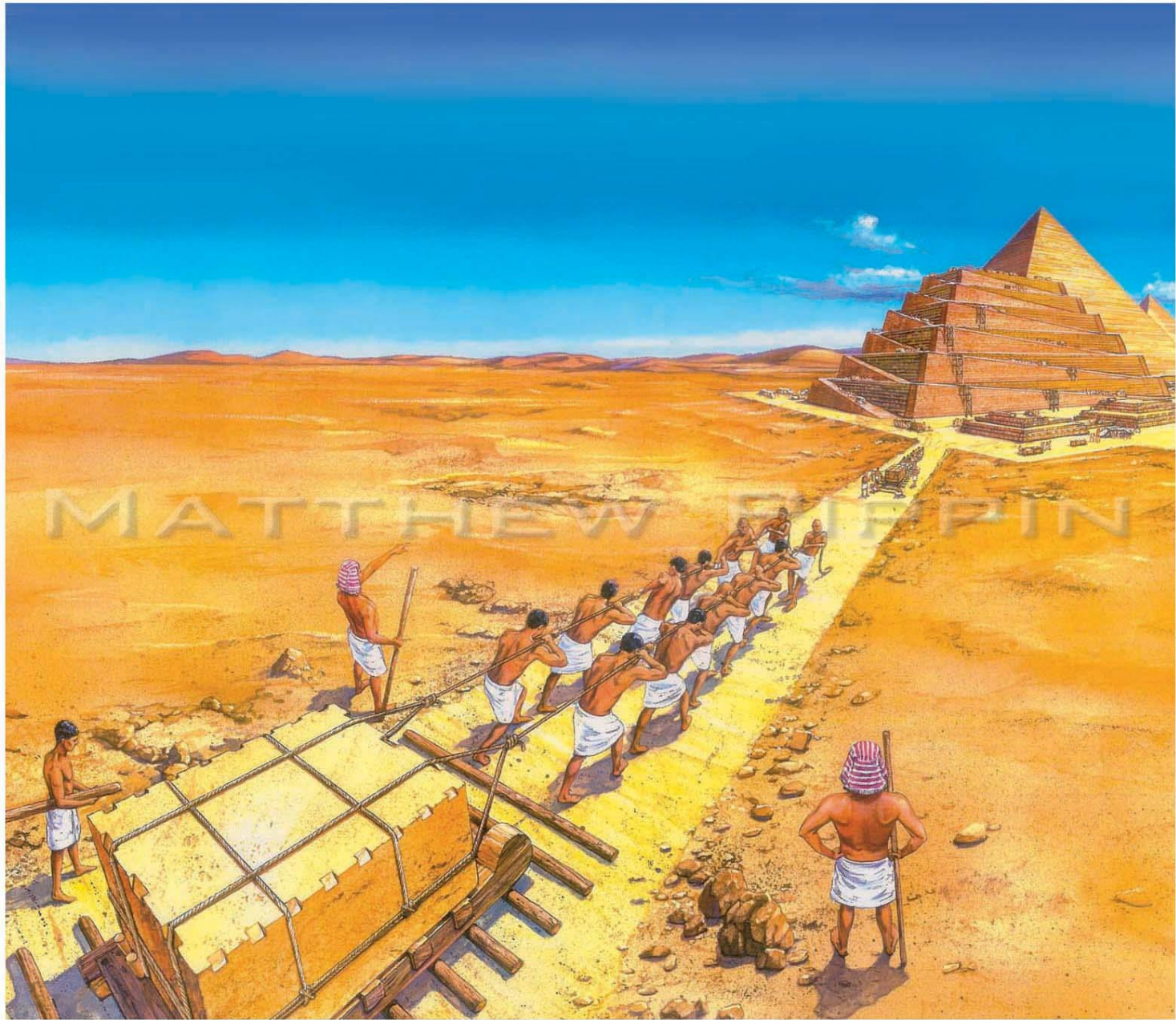

PLANTING RATHER THAN LIFTING AN OBELISK IN EGYPT

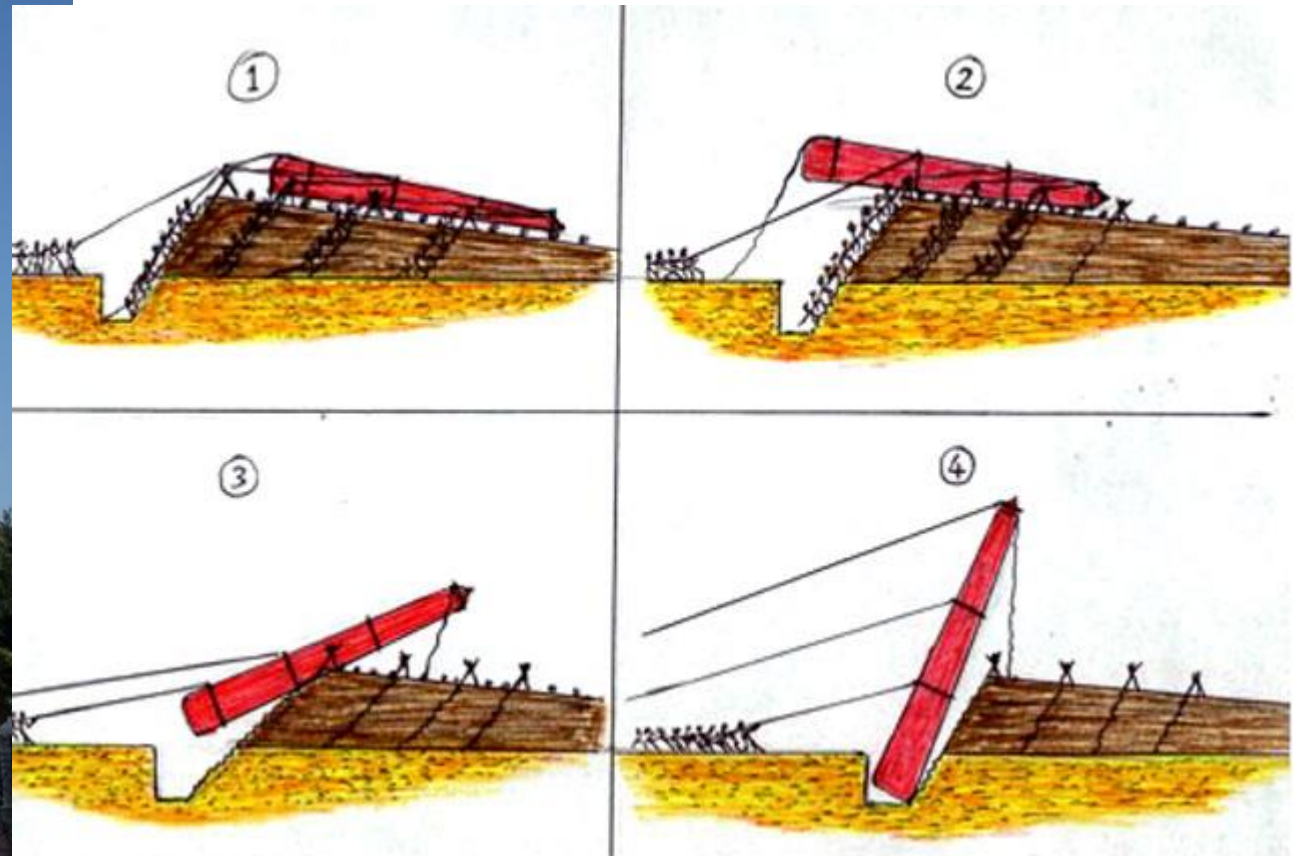

a platform.

Great

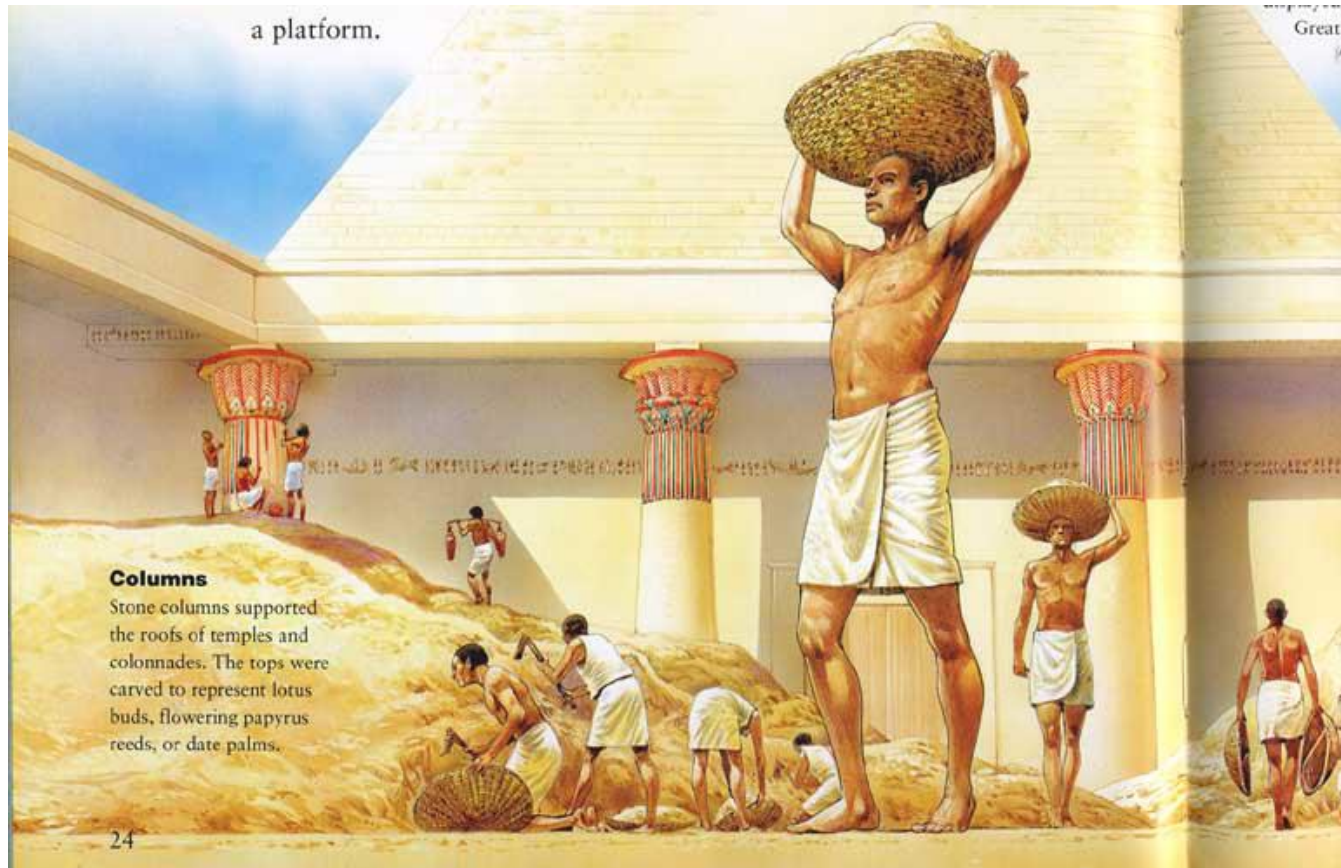

Columns

Stone columns supported the roofs of temples and colonnades. The tops were carved to represent lotus buds, flowering papyrus reeds, or date palms.

PORTARA ON NAXOS, LIFTED WITH CRANES



ΔΙΚΩΛΟΝ ANCIENT GREEK CRANE TYPES

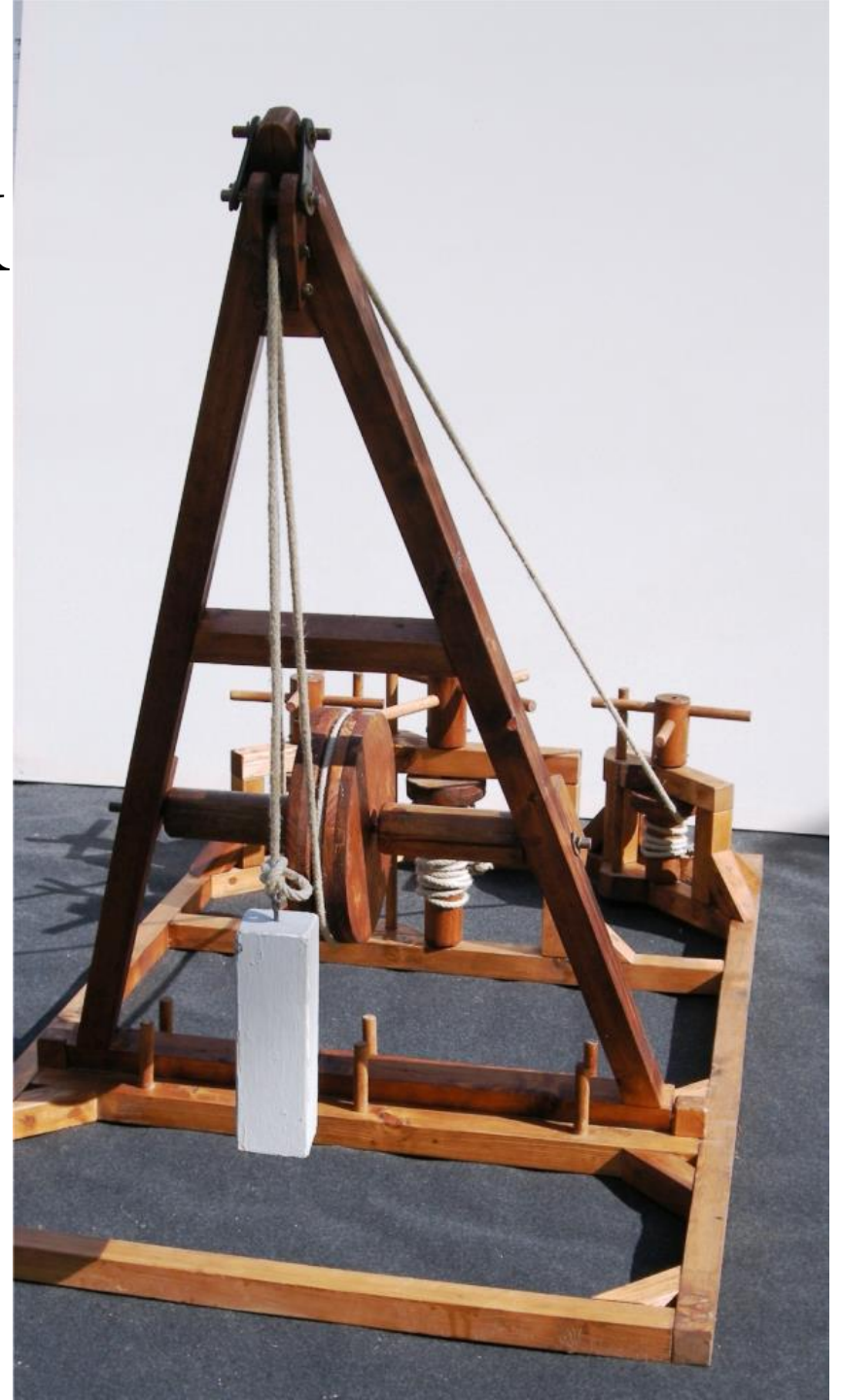



DAE-99016936 - © - DEA / G DAGLI ORTI



www.strenas.com

ROMAN RELIEFS WITH CRANES

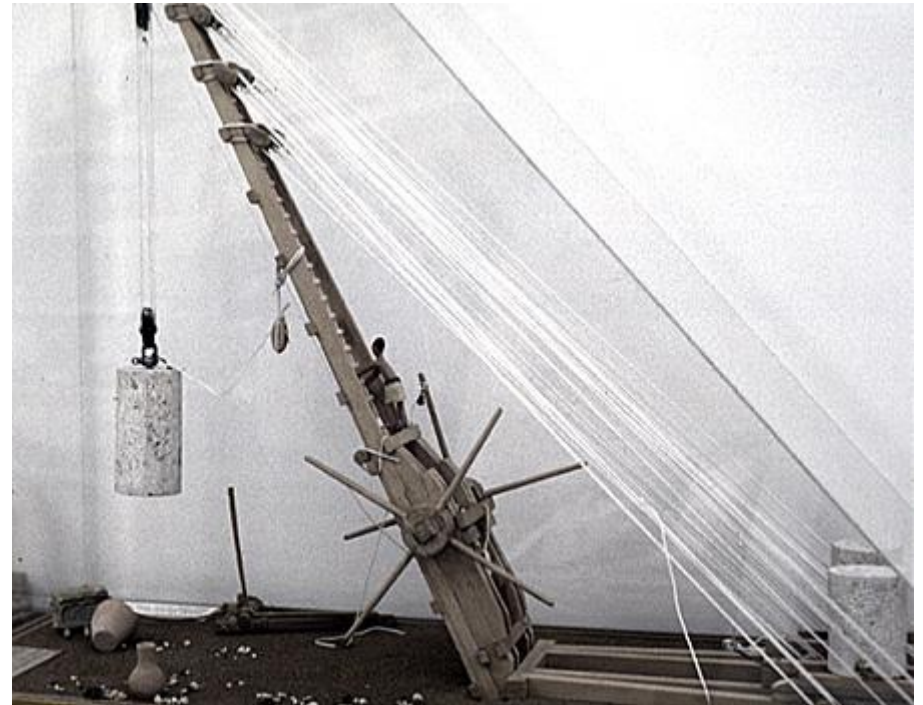

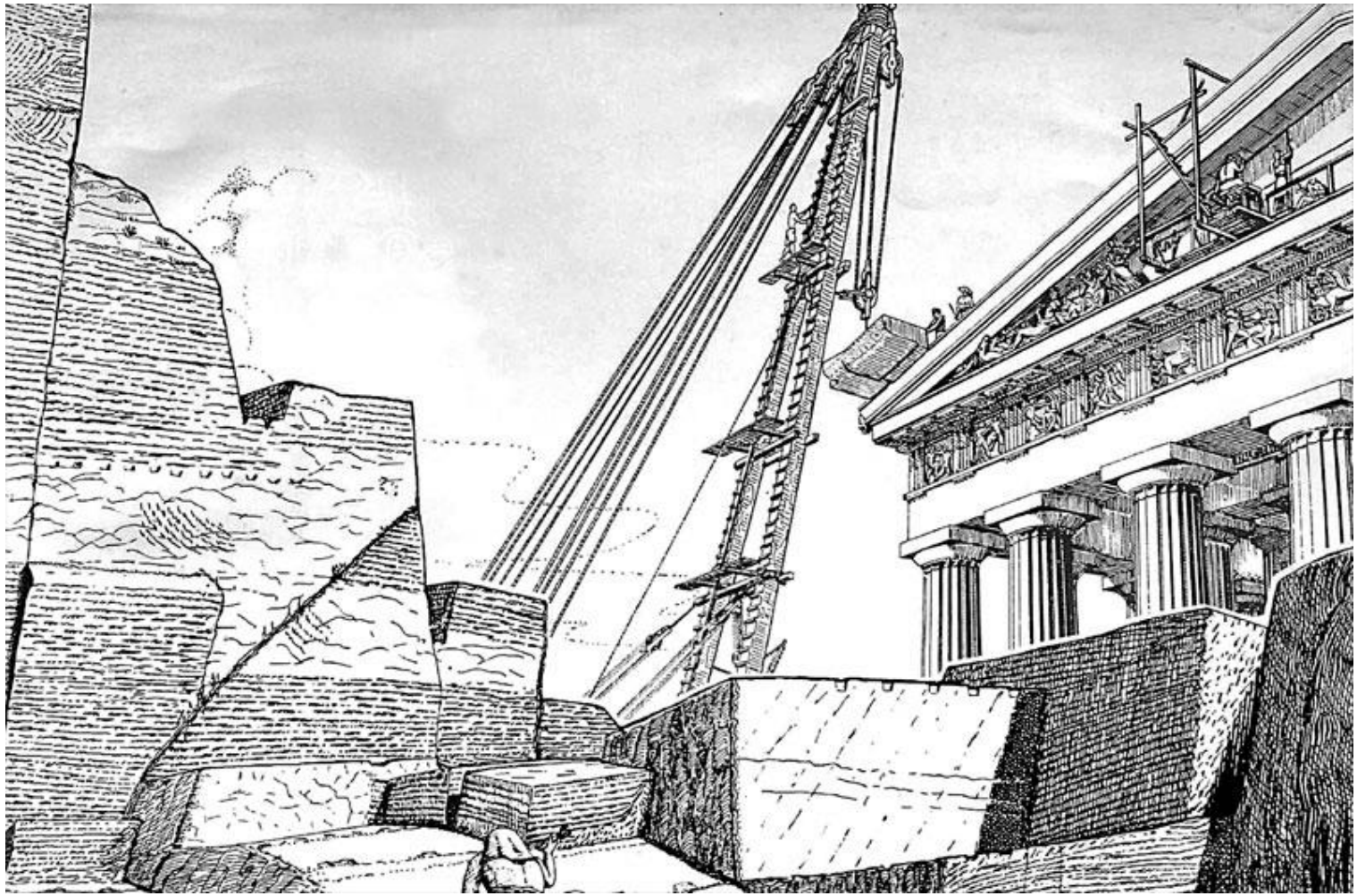

Επιφώση των μαρμάρινων όγκων, από
βιβλίο Μ. Κορρέ "Απο την Πεντέλη
στον Παρθενώνα", 1993©

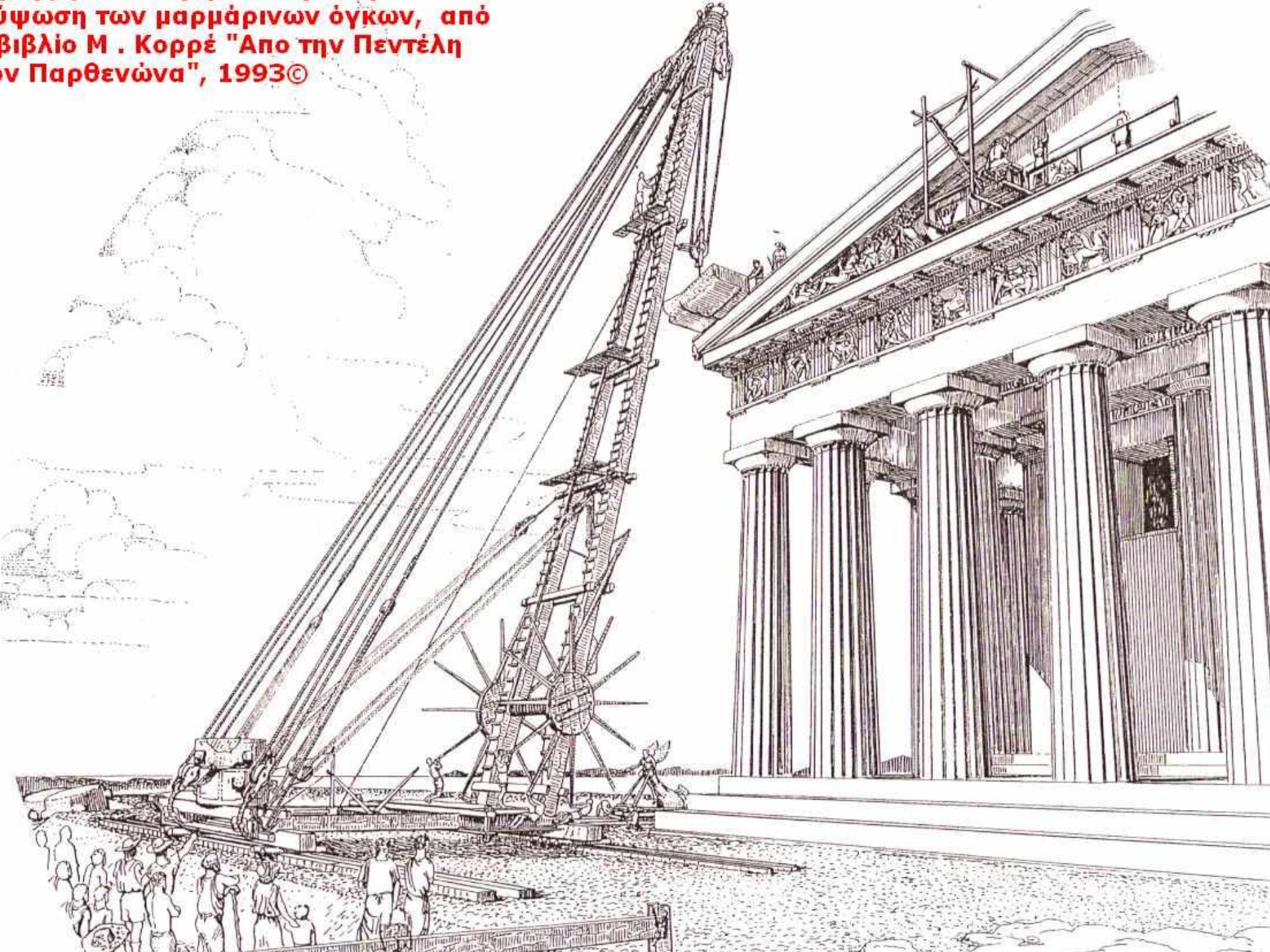



BLOCKS AND PULLEYS



LACK OF PULLEYS IN EGYPT





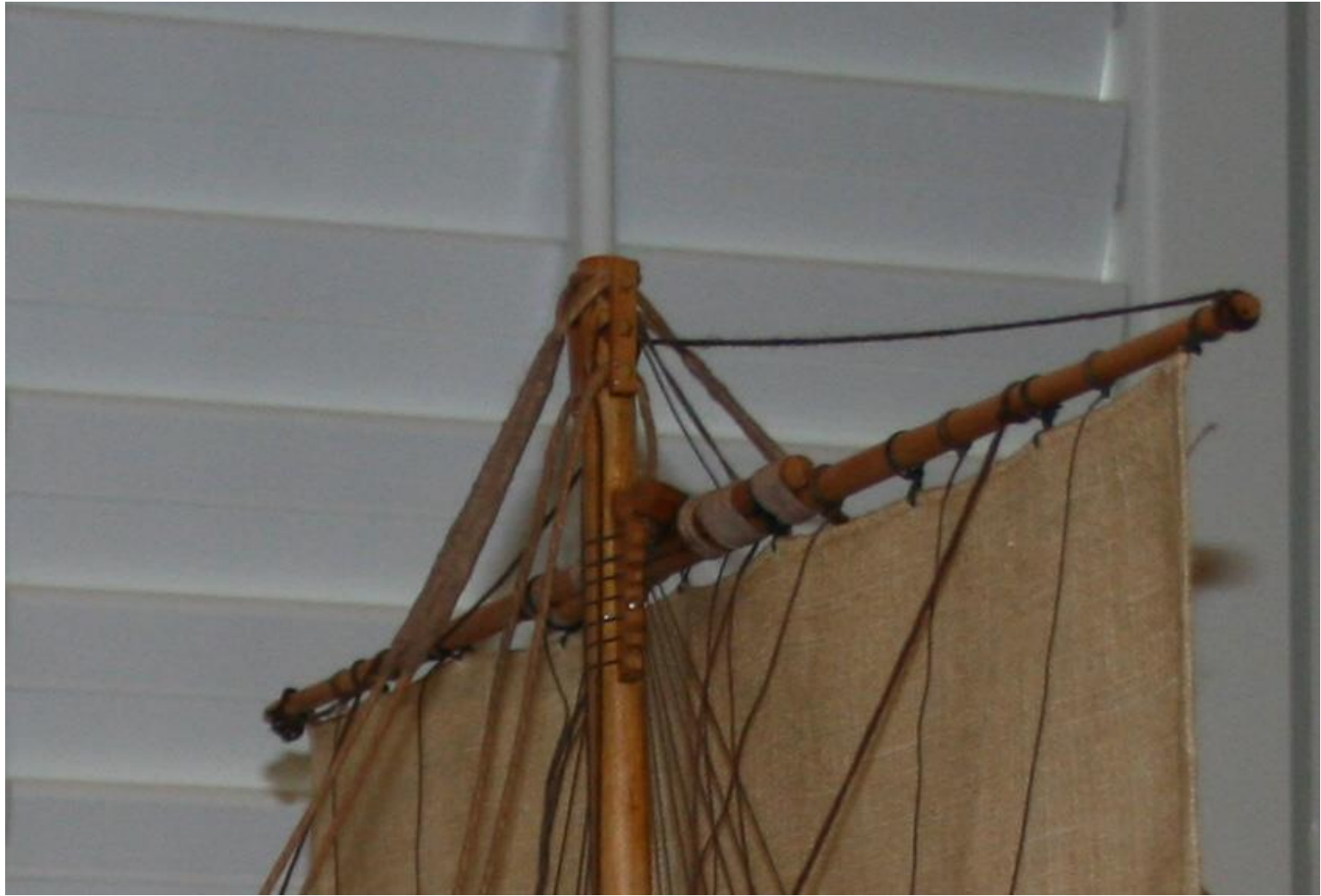

LIFTING DEVICES. GROOVES FOR THE INSERTION OF ROPES

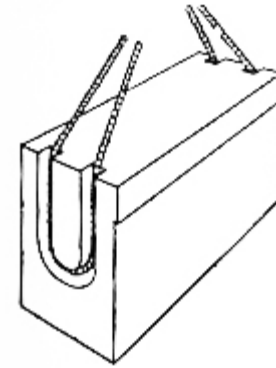



THE LEWIS

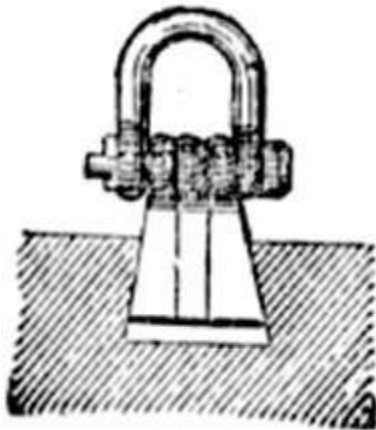
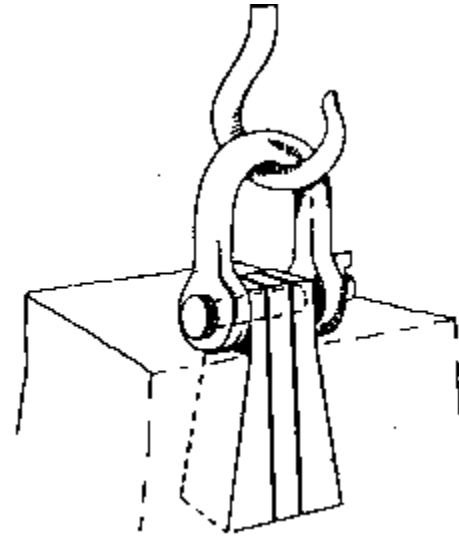
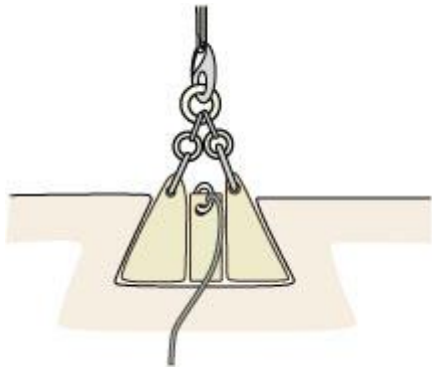

STONE CRAAB

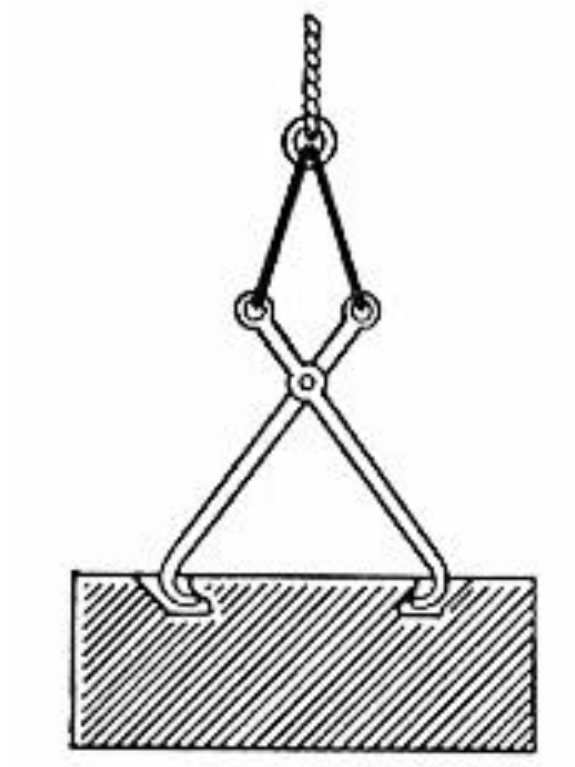

LIFTING BOSSES. PORTARA ON NAXOS



BOSSSES IN THE TEMPLE OF ZEUS IN AETOLIA



LIFTING BOSSES IN THE TEMPLE OF APOLLO AT DIDYMA



**OVAL PIAZZA – GERASA
NOTE THE LIFTING BOSSES ON COLUMN
SHAFTS**



BOSES THAT HELP MANIPULATE THE BLOCK WITH CROWBARS

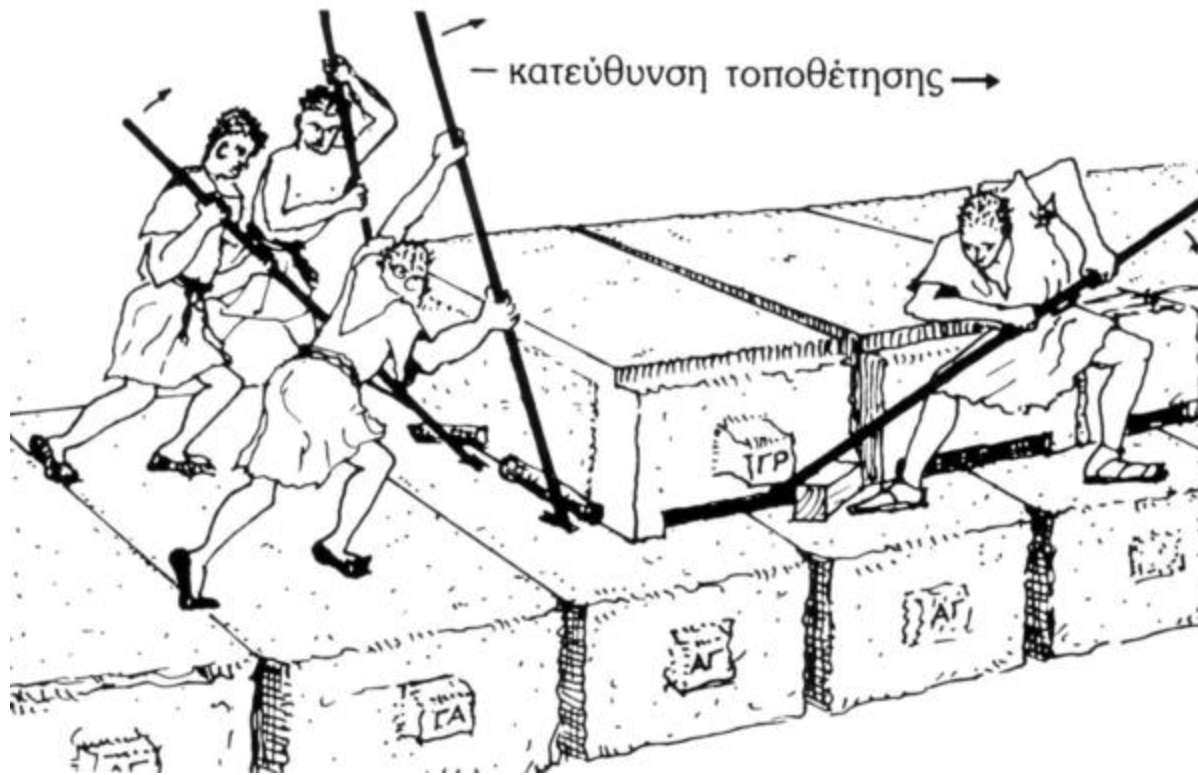

DECORATIVE BOSSES IN ROMAN AND RENNAISANCE

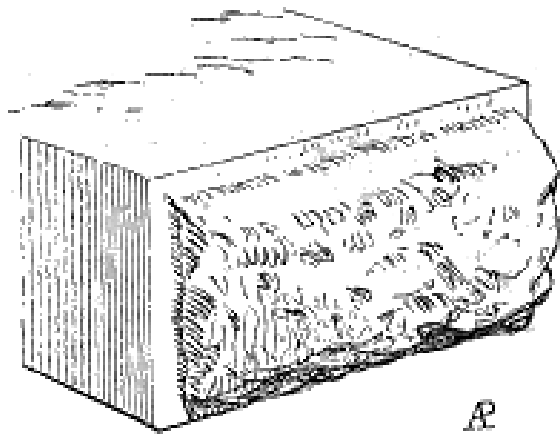

1







PRY HOLES AND CROWBARS

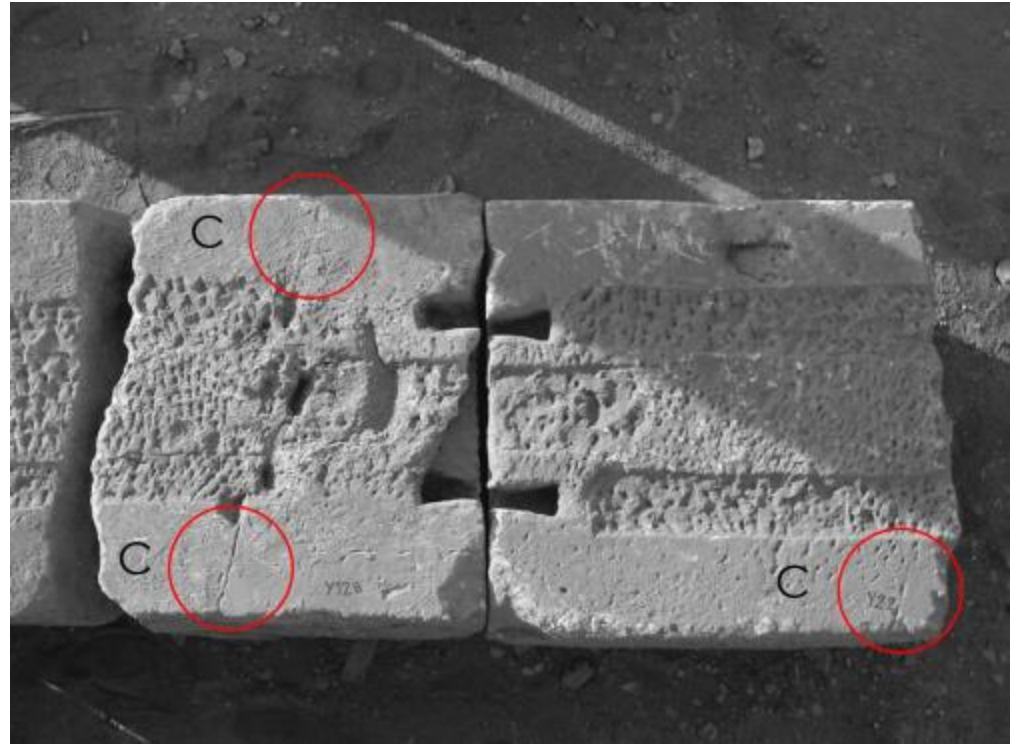
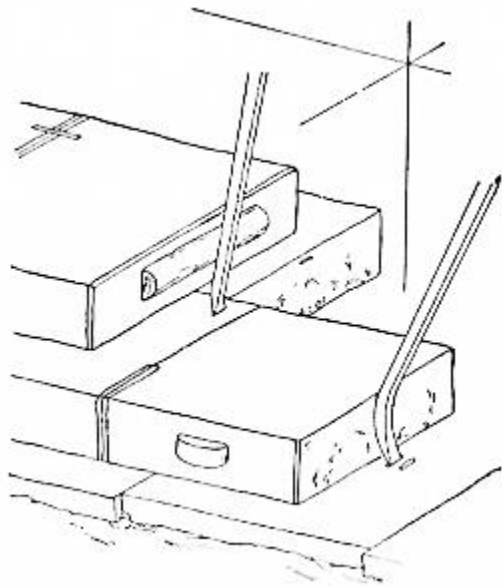

CROW BARS

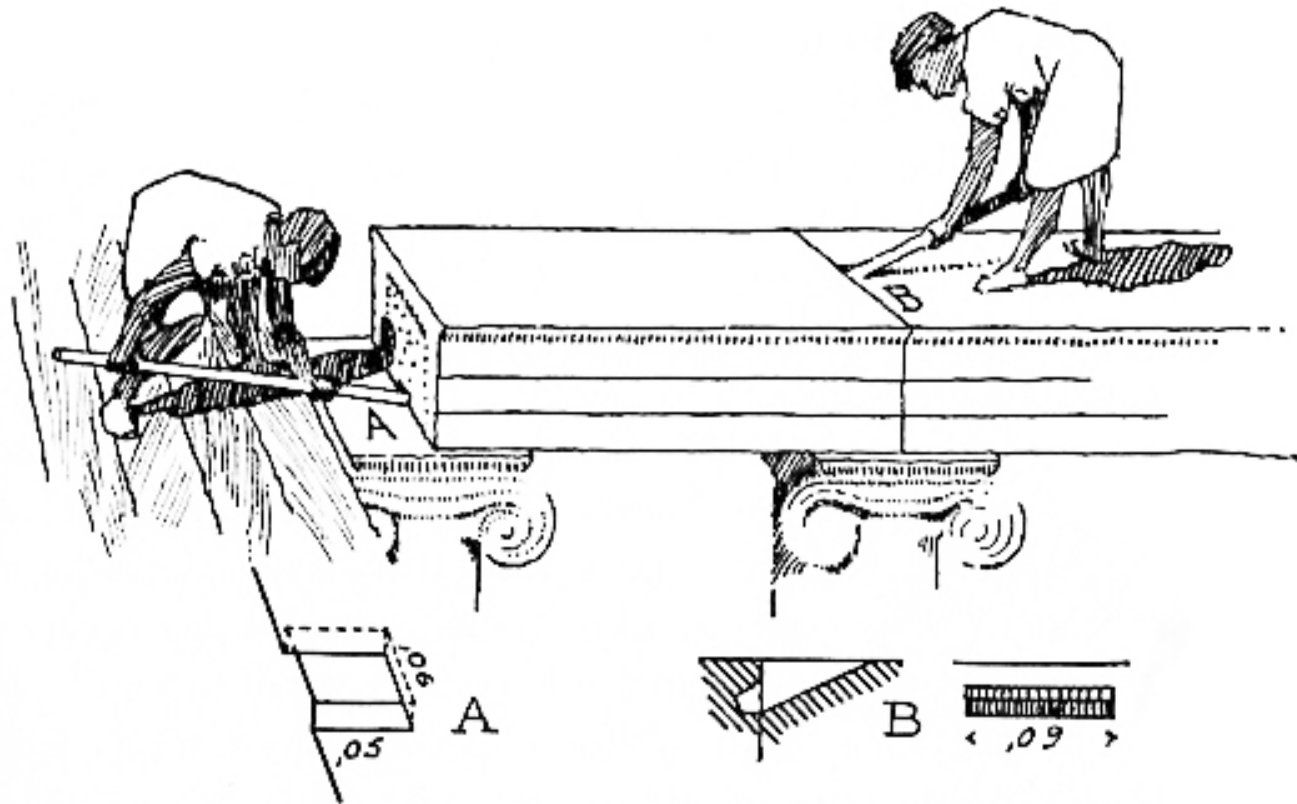

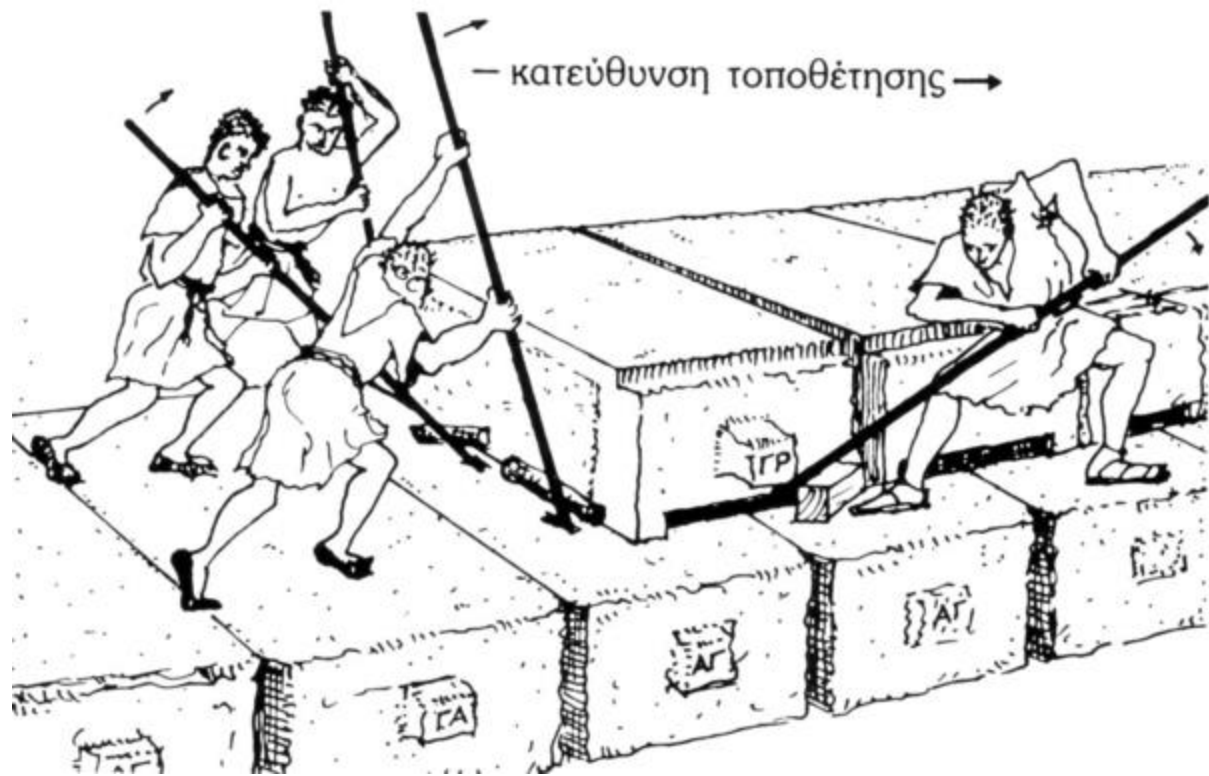

CLAMPS

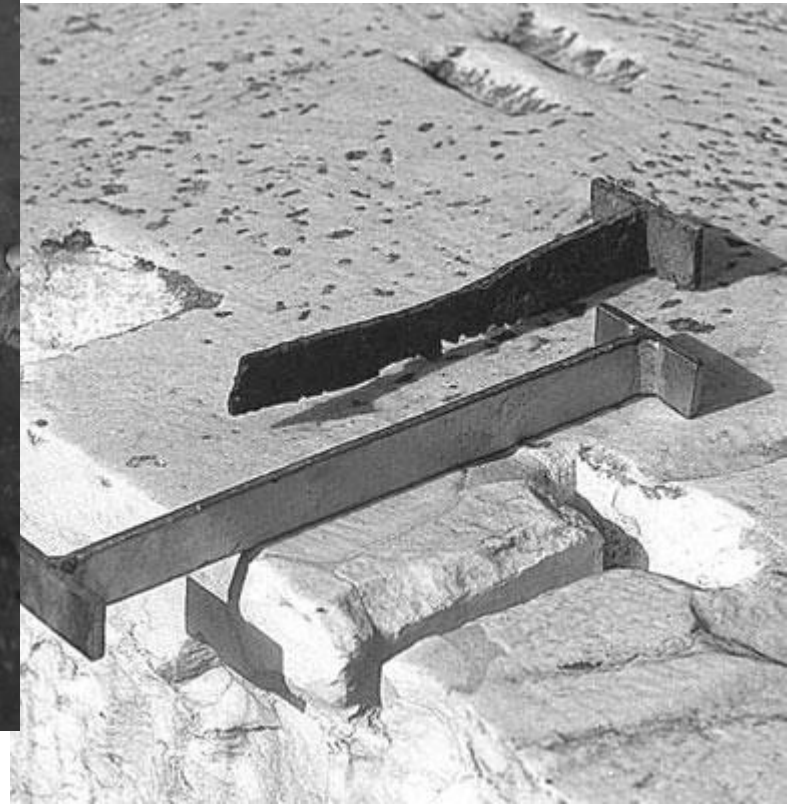
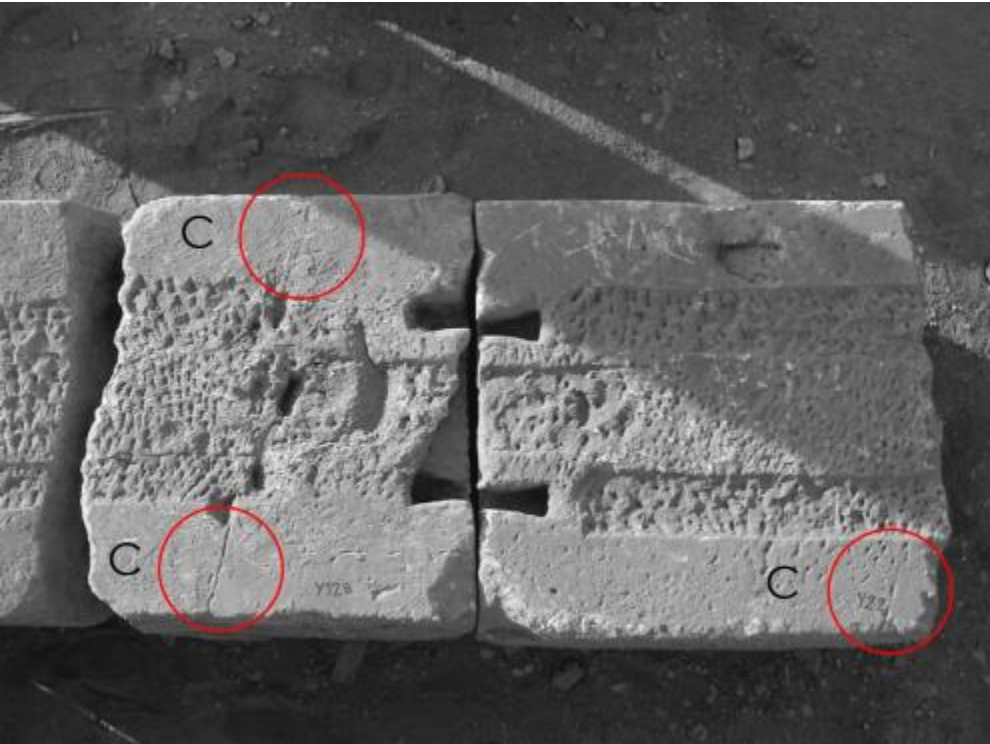

DOWELS – PEGS FOR VERTICAL CONNECTION OF BLOCKS

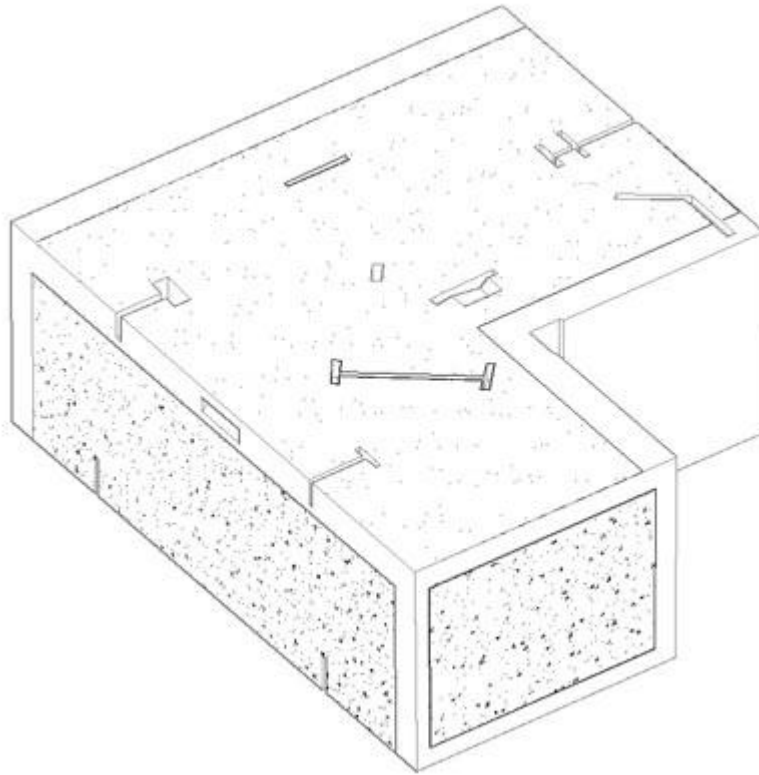

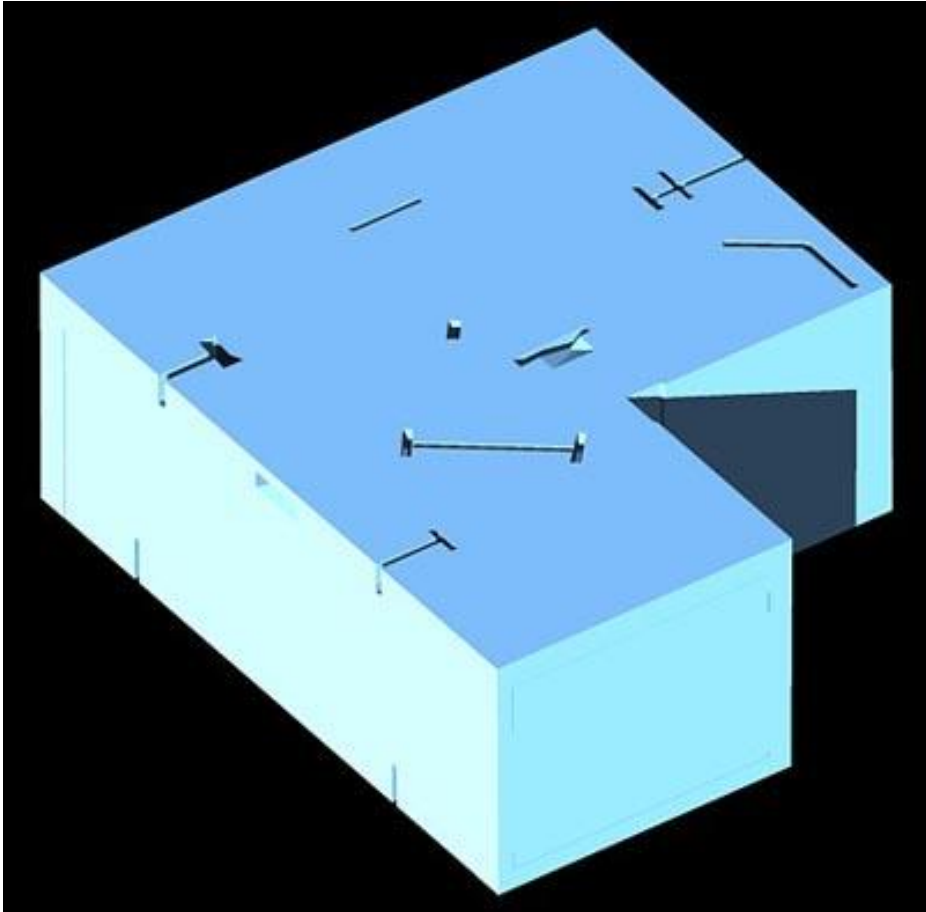

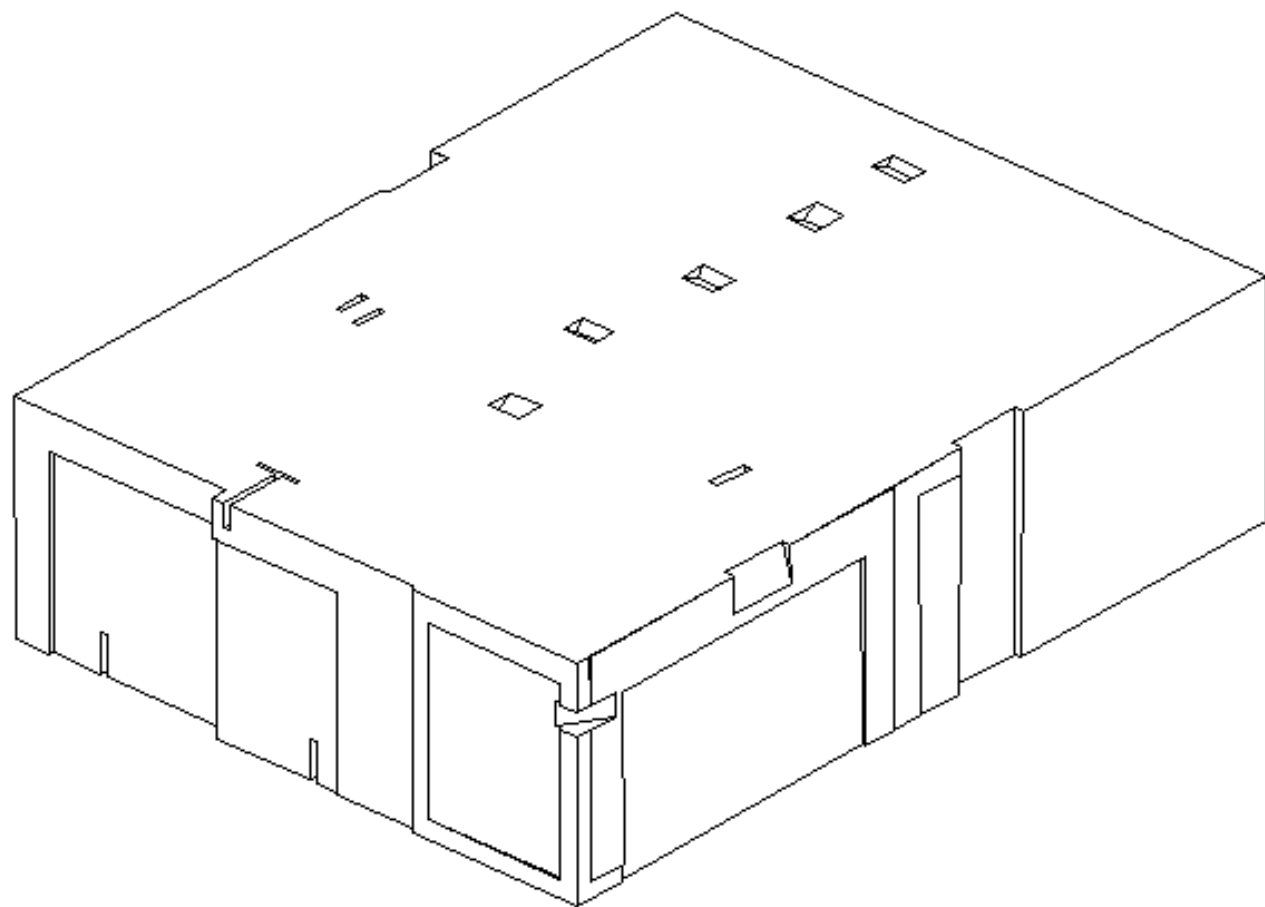



PEGS IN COLUMN DRUMS

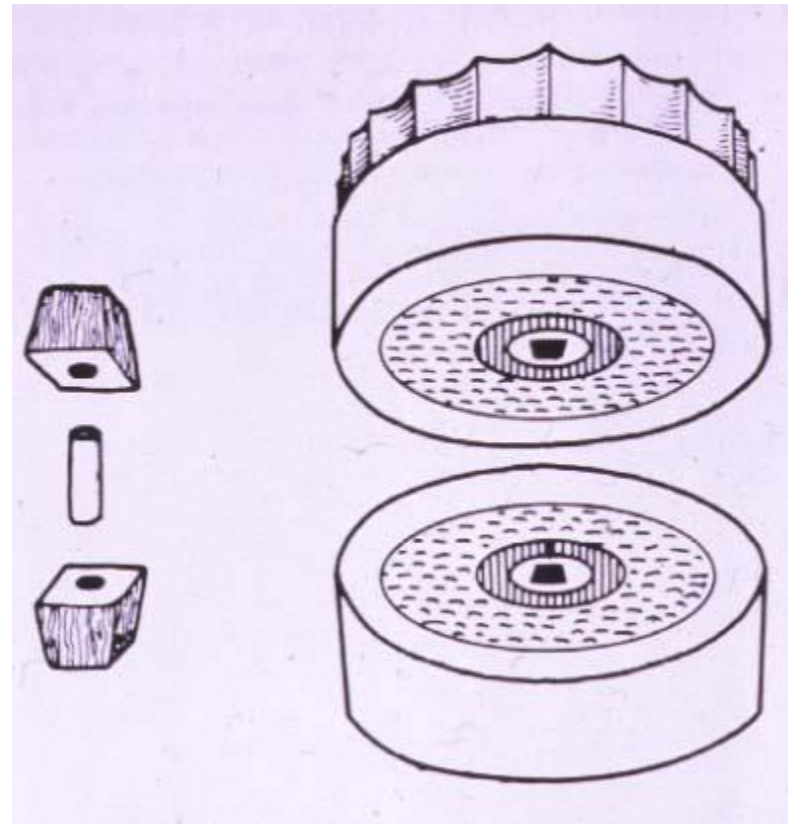
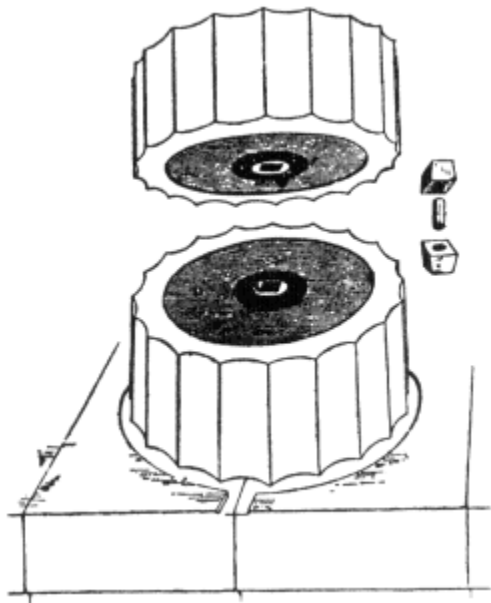



STAGES OF CARVING THE BLOCKS

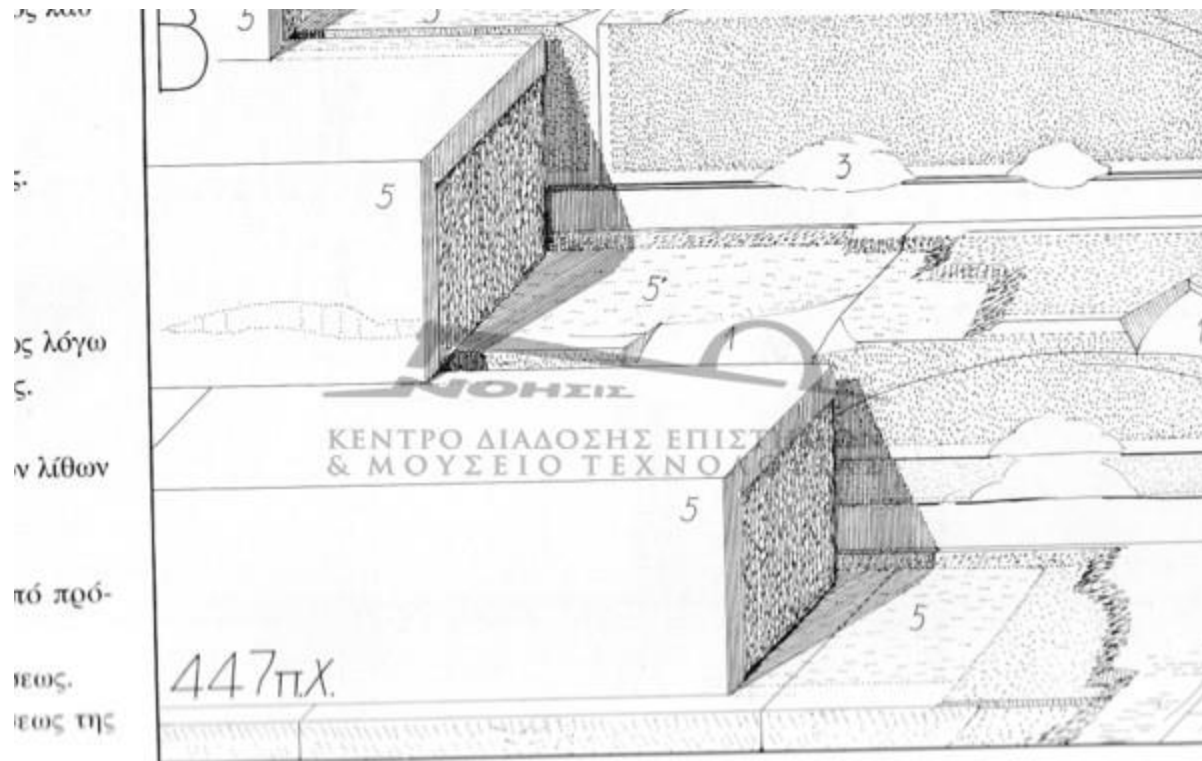

TEMPLE OF APOLLO AT DIDYMA



«φιλοκαλούμεν μετ'ευτελείας ... » Περικλής, *Επιτάφιος*.
Th. Kalraxis, *Hemiteles*, 1986







ΝΑΟΣ ΤΟΥ ΔΙΟΣ ΣΤΗ ΣΤΡΑΤΟ ΑΙΤΩΛΙΑΣ

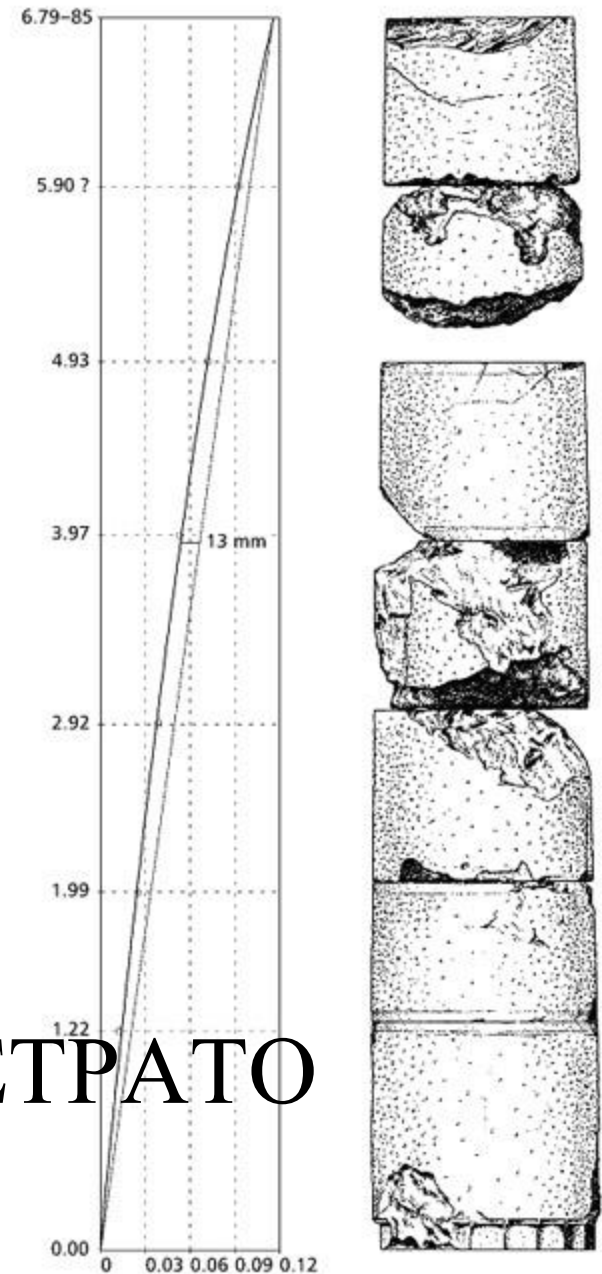

UNFINISHED COLUMN SHAFTS IN SEGESTA, ITALY



UNFINISHED COLUMN DRUMS OF THE PERPARTHENON



ANATHRYOSIS/ BAND OF CONTACT ON THE TRUST JOINTS OF BLOCKS

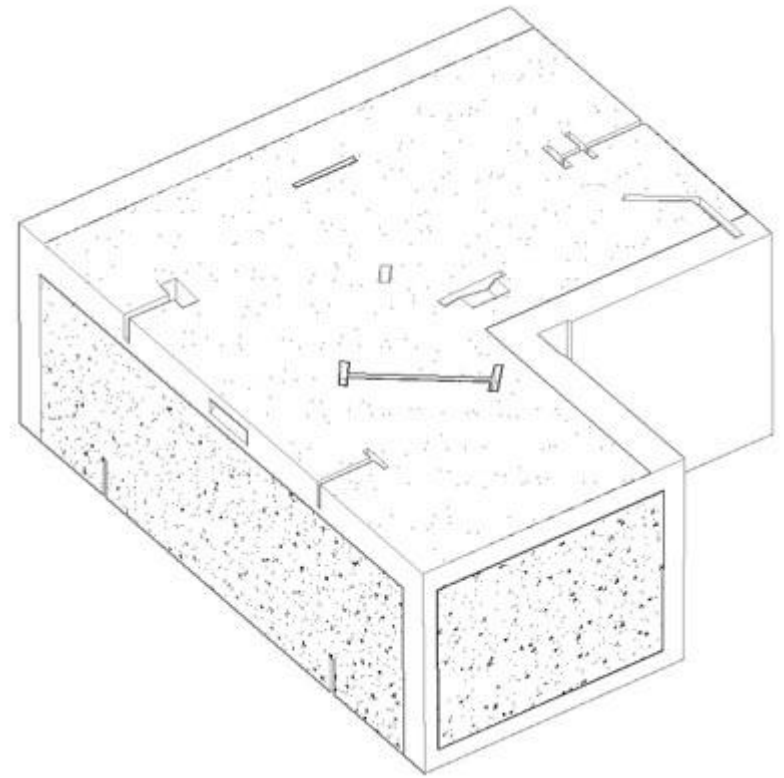

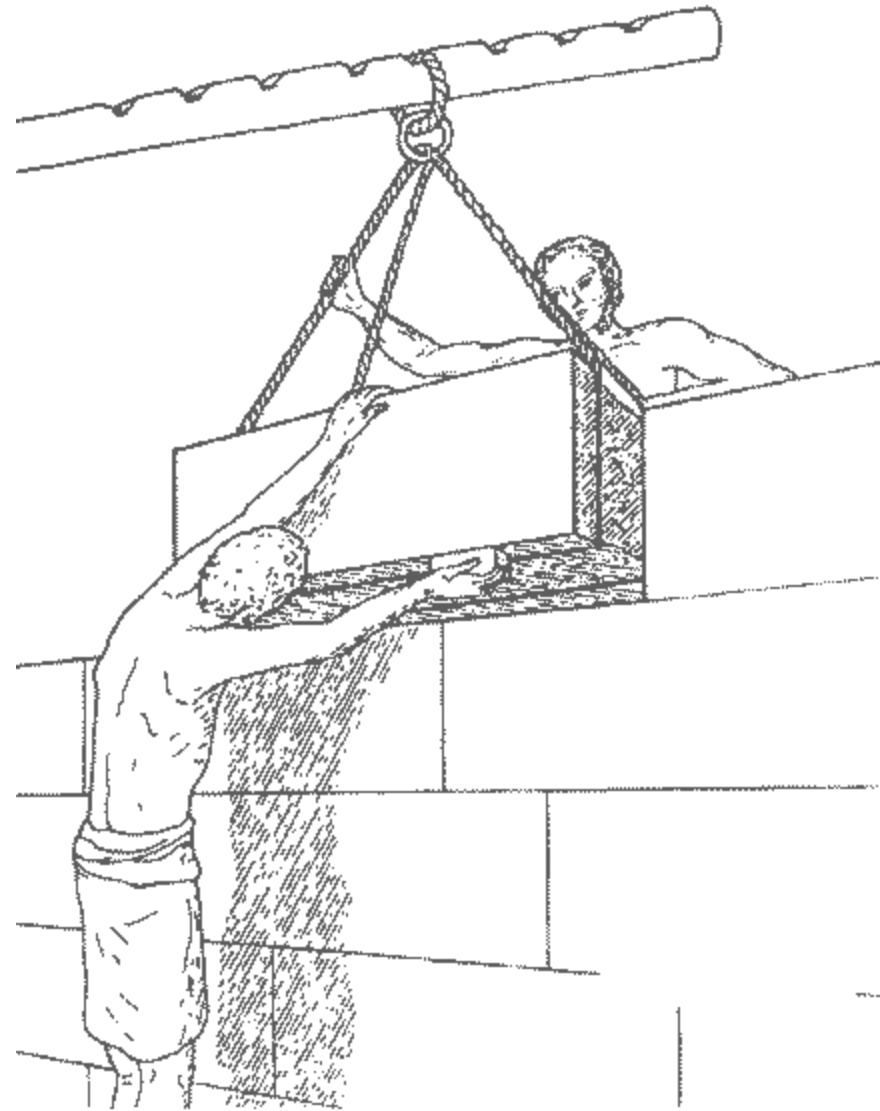
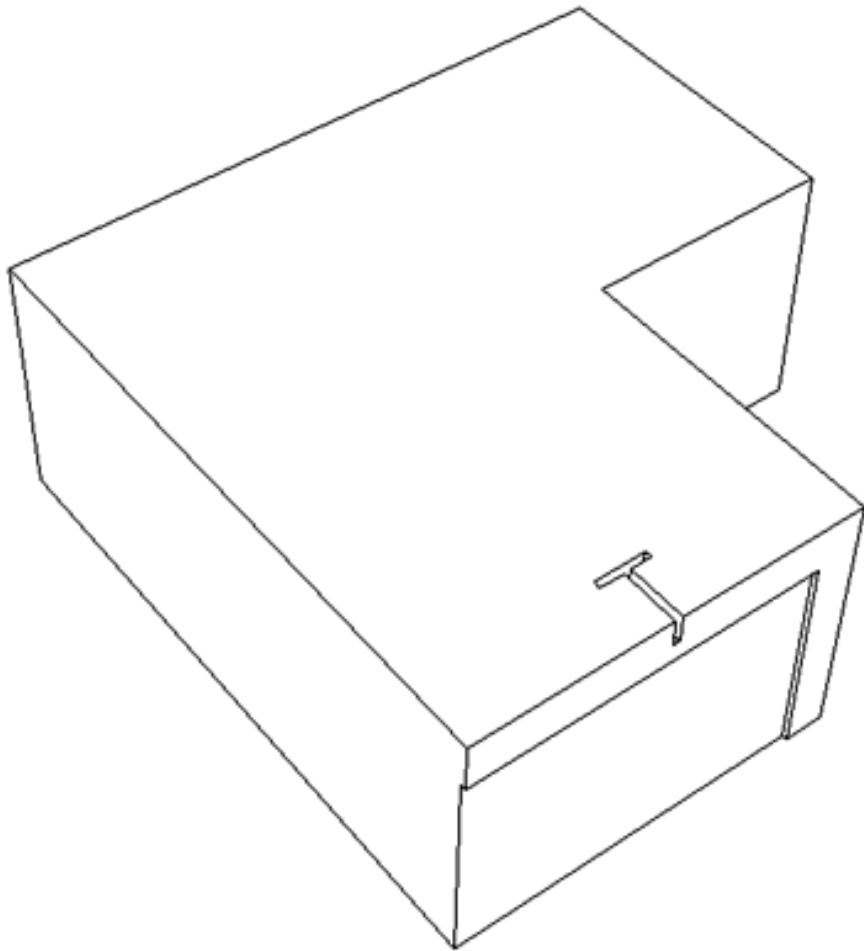

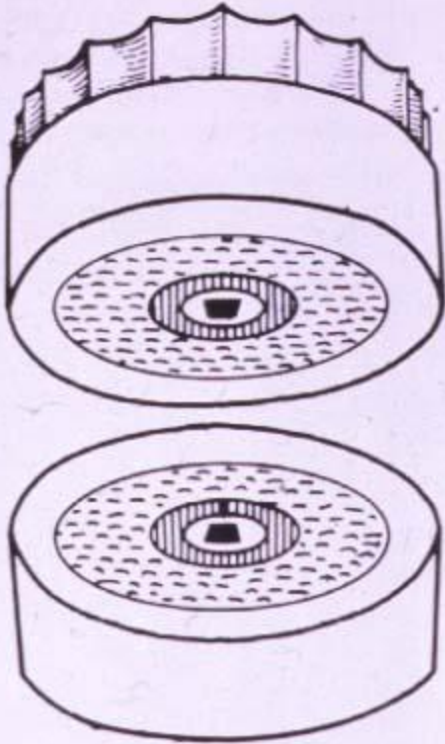
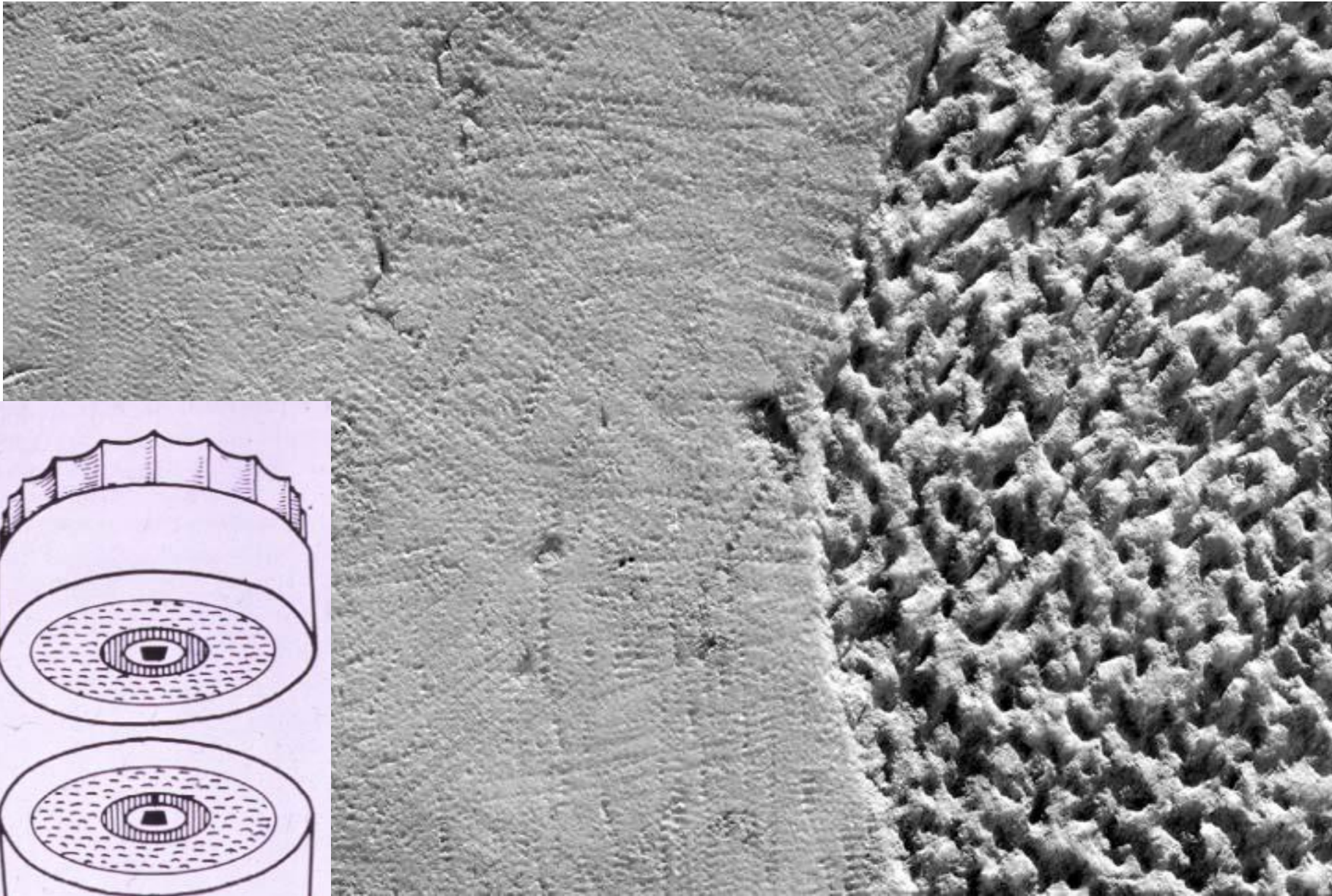



4



3

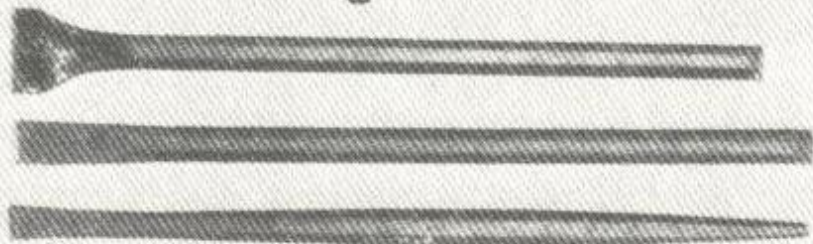

2

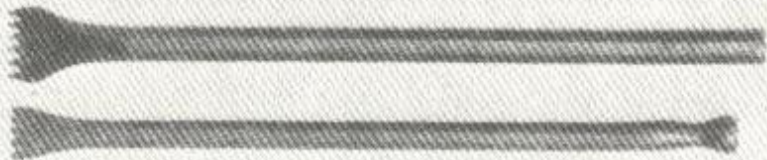

1



6



5

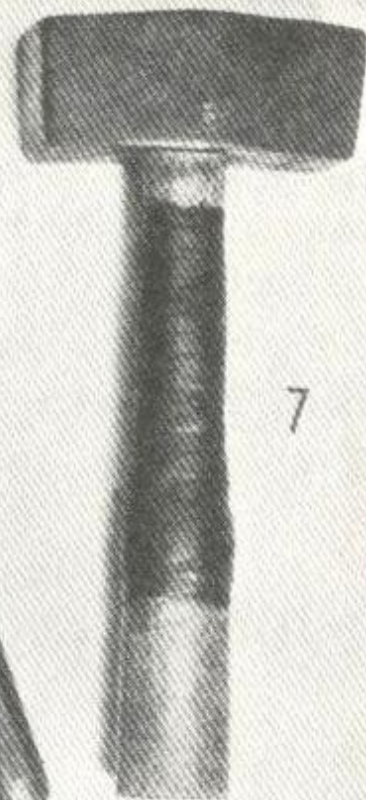

7

SCULPTORS' TOOLS FOR CARVING HARD ROCKS.

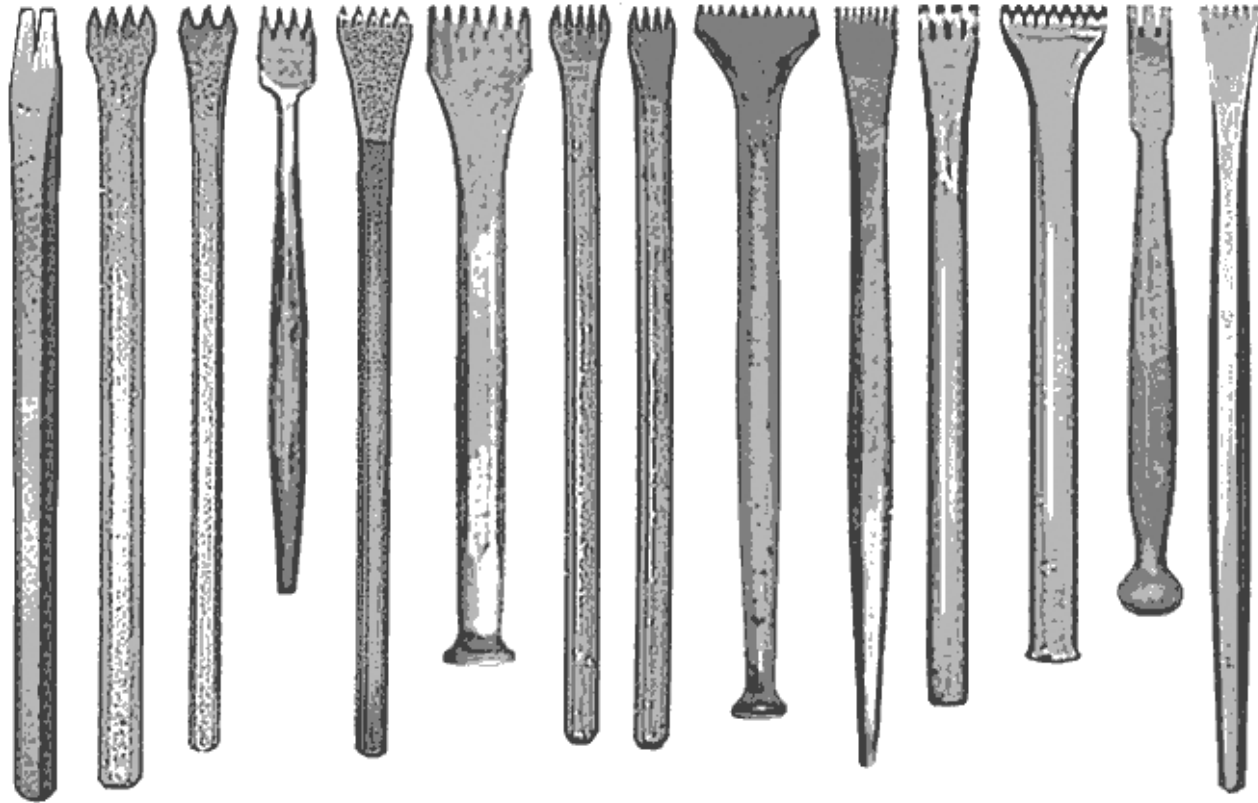

ROMAN CHISELS



PIQUE



www.shutterstock.com · 101612950

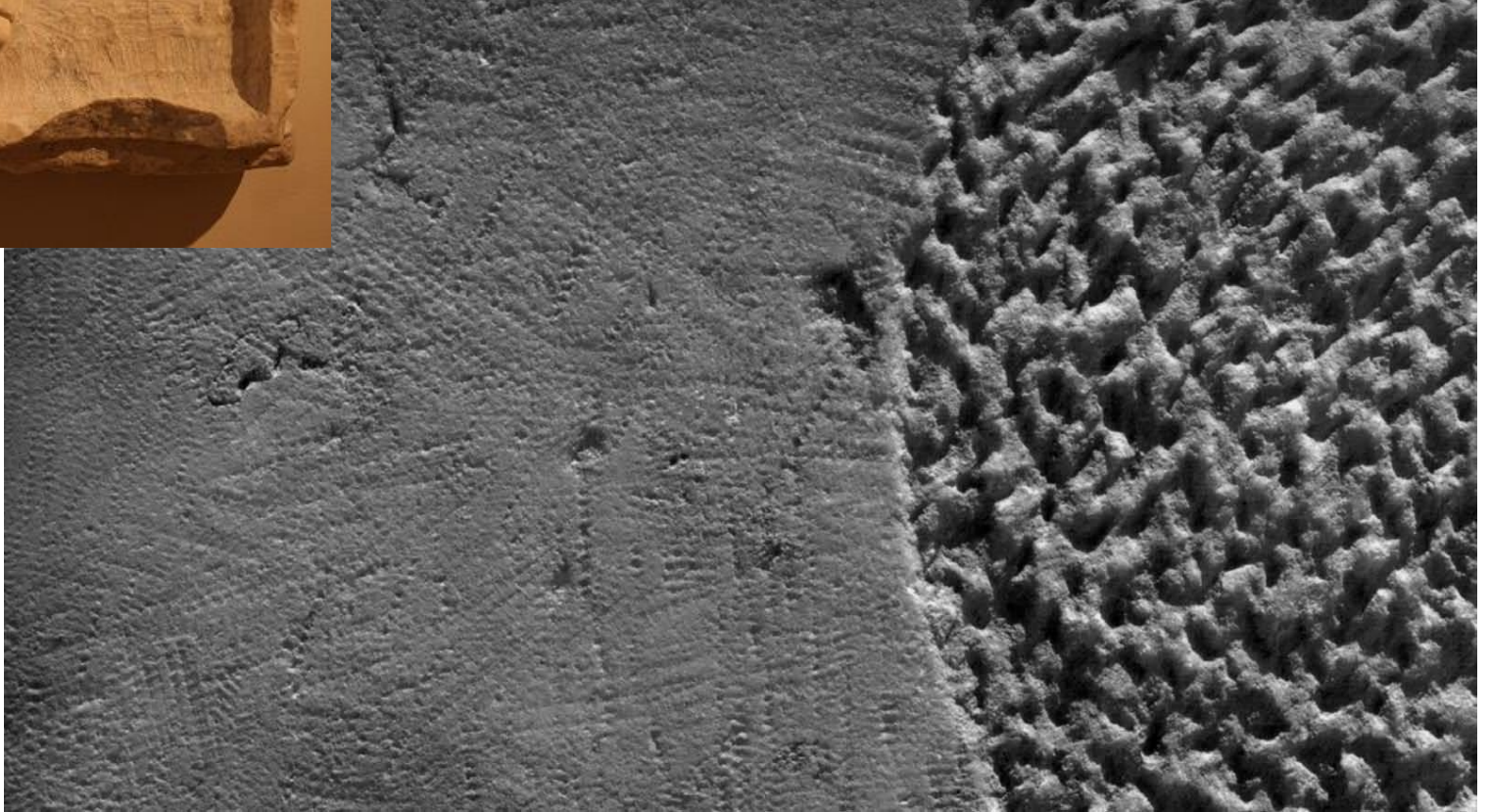

CLAWED CHISEL



ΤΟΙΧΟΔΟΜΙΕΣ, ΑΡΜΟΙ ΚΟΝΙΑΜΑΤΑ

- ΤΟΙΧΟΔΟΜΙΕΣ, ΑΡΜΟΙ ΣΤΟΥΣ ΕΛΛΗΝΕΣ
ΑΡΜΟΙ
ΚΟΝΙΑΜΑΤΑ





©2001 Brandon Cline



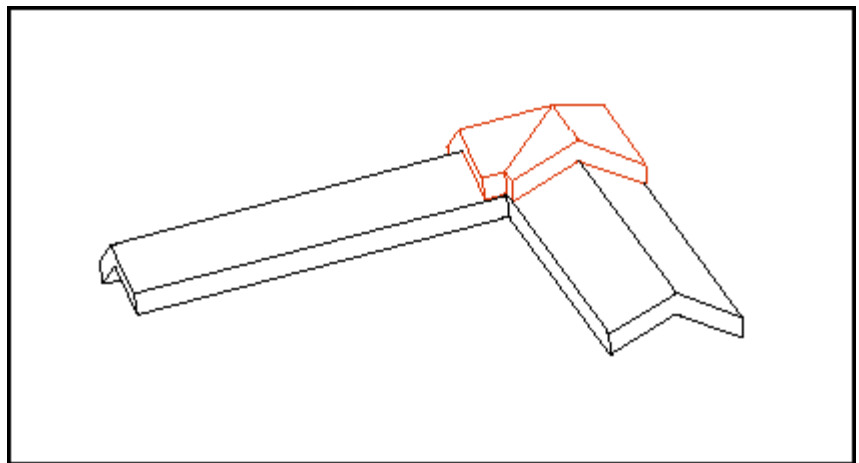
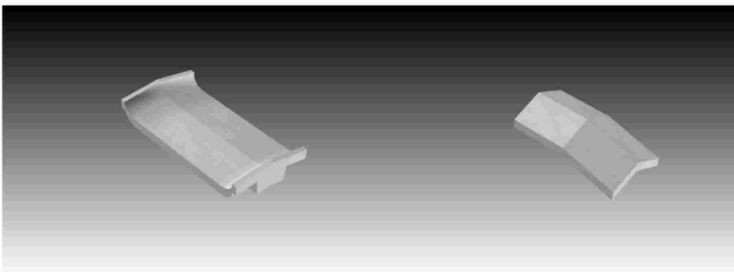
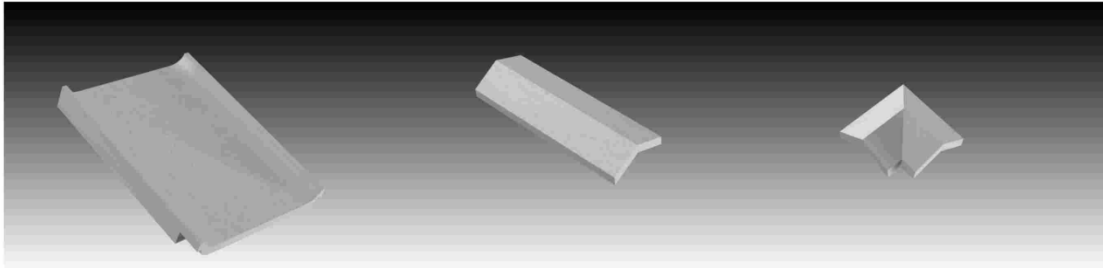
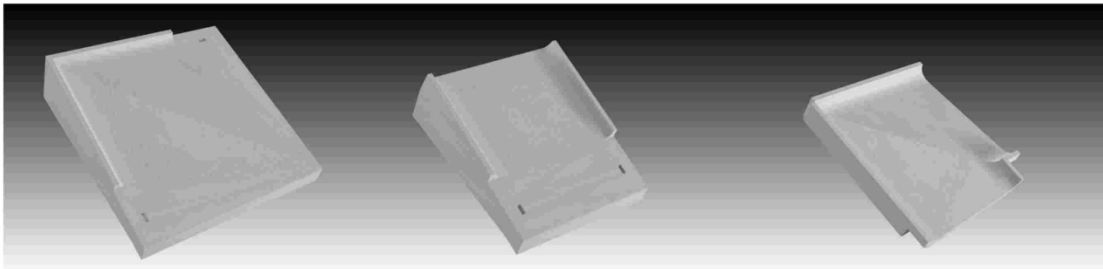



**ΛΟΥΤΡΑ ΑΓΟΡΑΣ.
ΣΤΑΒΙΑ**









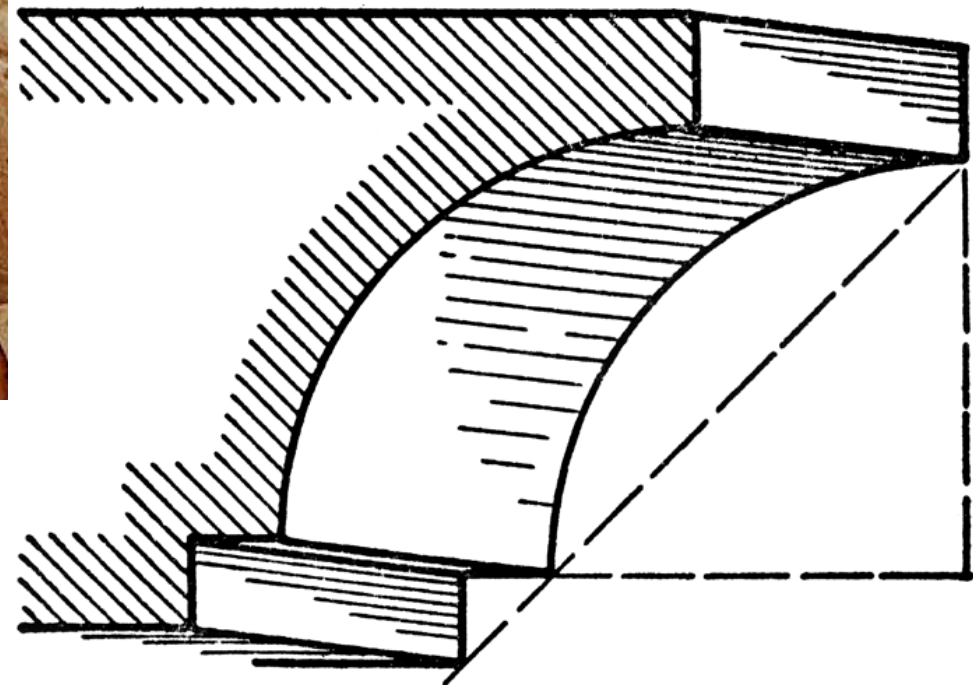
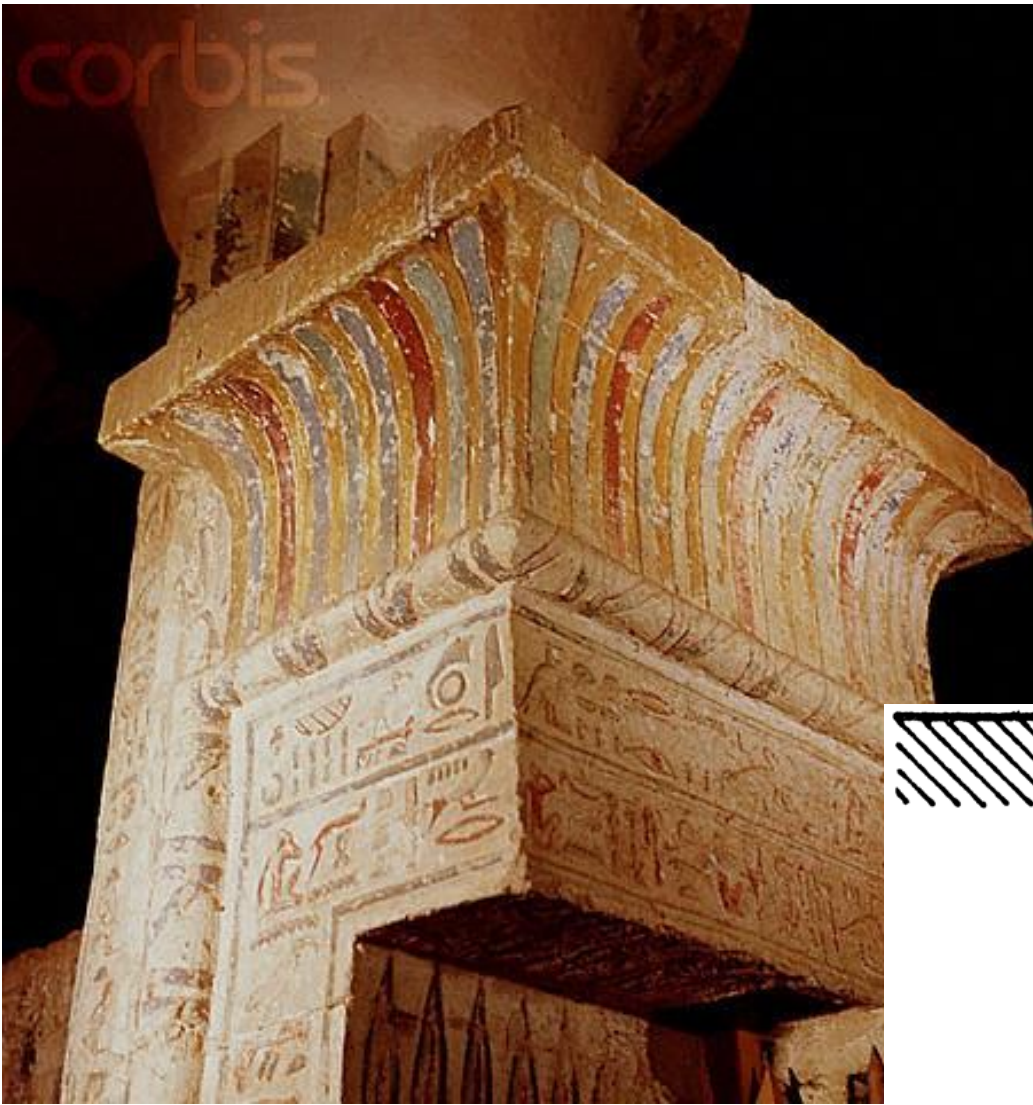

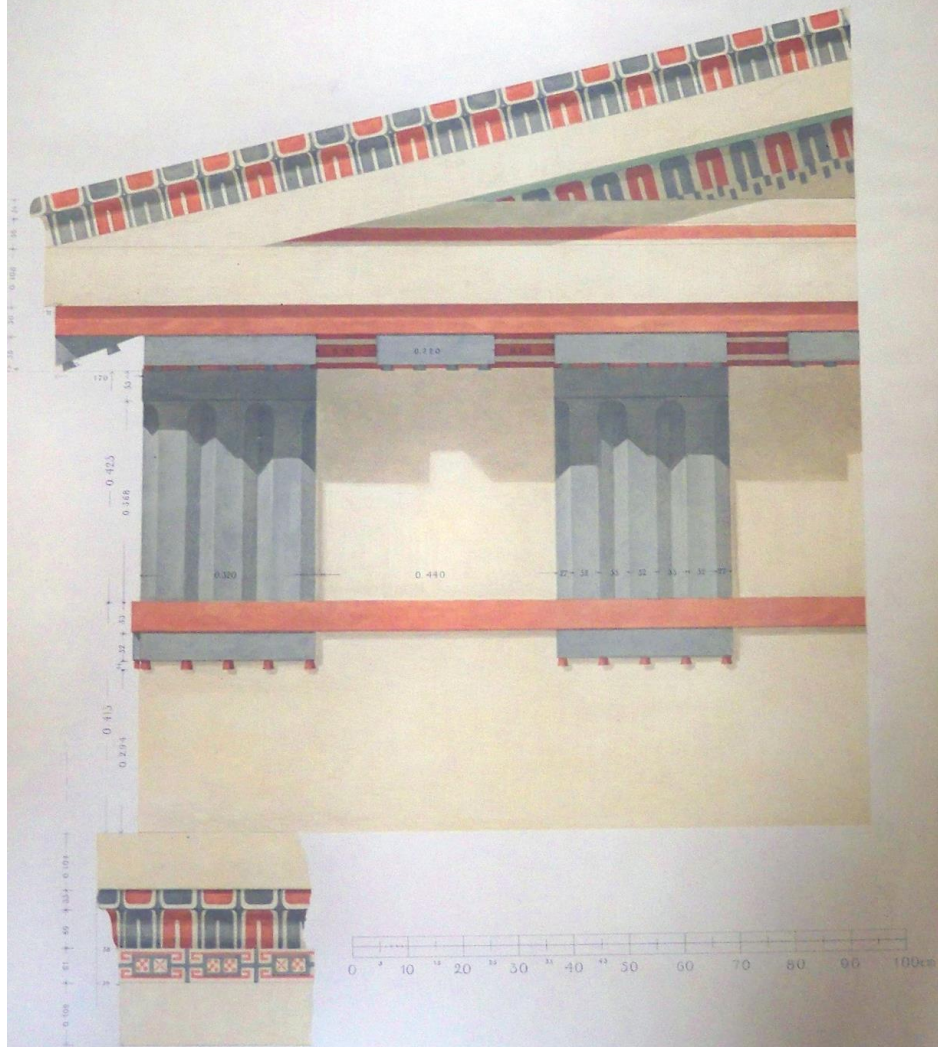

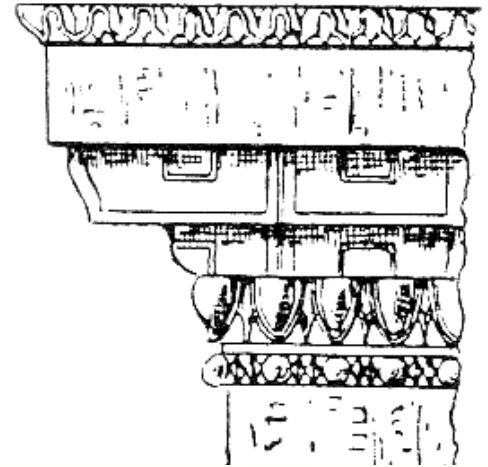
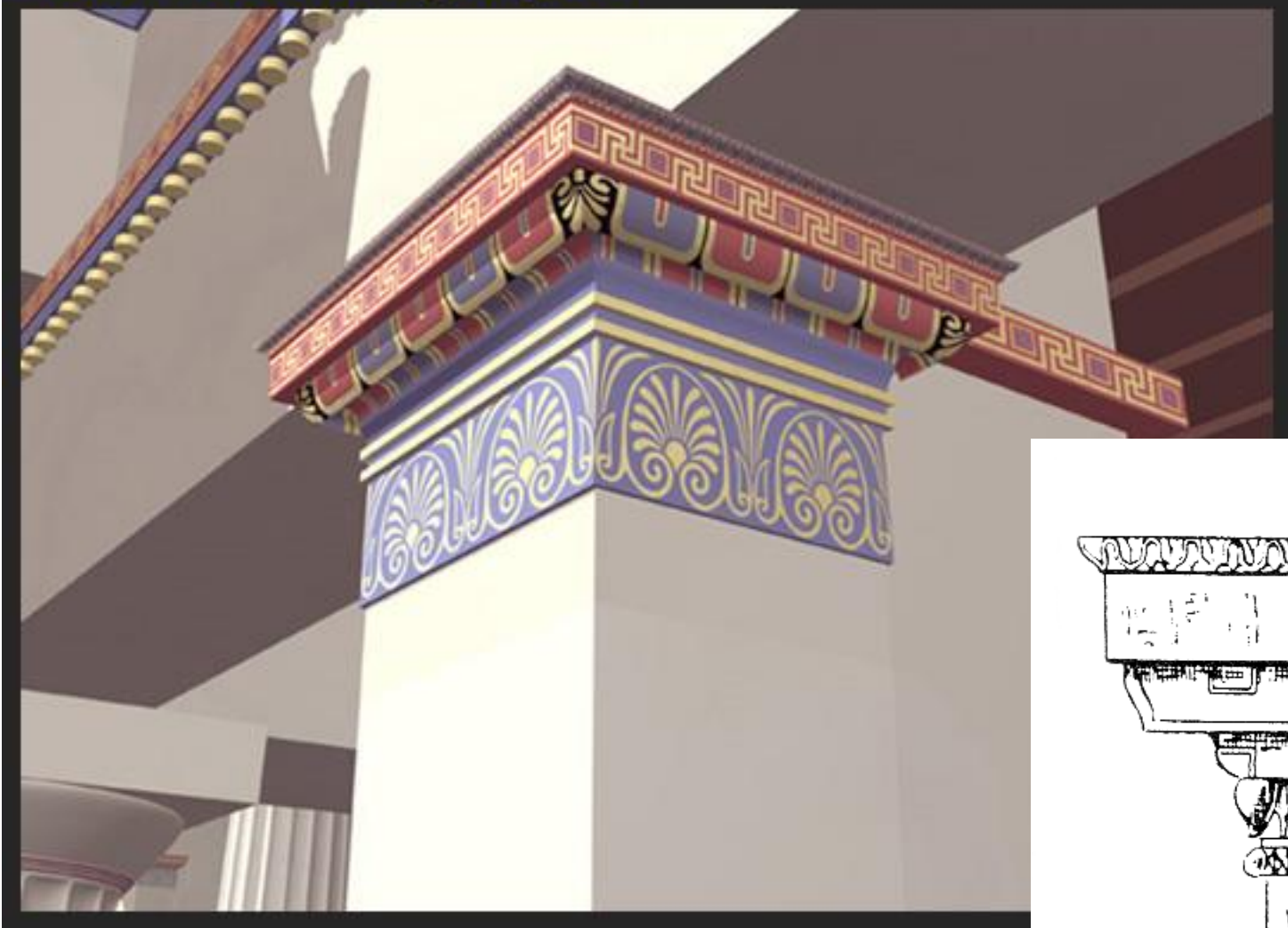

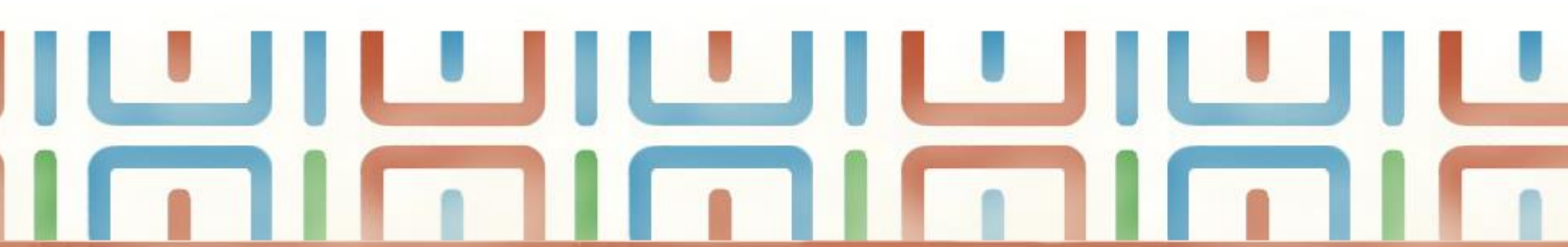

- ΑΙΓΥΠΤΙΑΚΟ GORGE
- CAVETTO
- ΚΟΙΛΟ ΚΥΜΑΤΙΟ
- ΤΕΤΑΡΤΟΚΥΚΛΙΚΗΣ ΔΙΑΤΟΜΗΣ

- ΗΑWKSΒΕΑΚ / ΒΕΑΚ
- ΔΩΡΙΚΟ ΦΥΛΛΟ
- ΡΑΜΦΟΣ

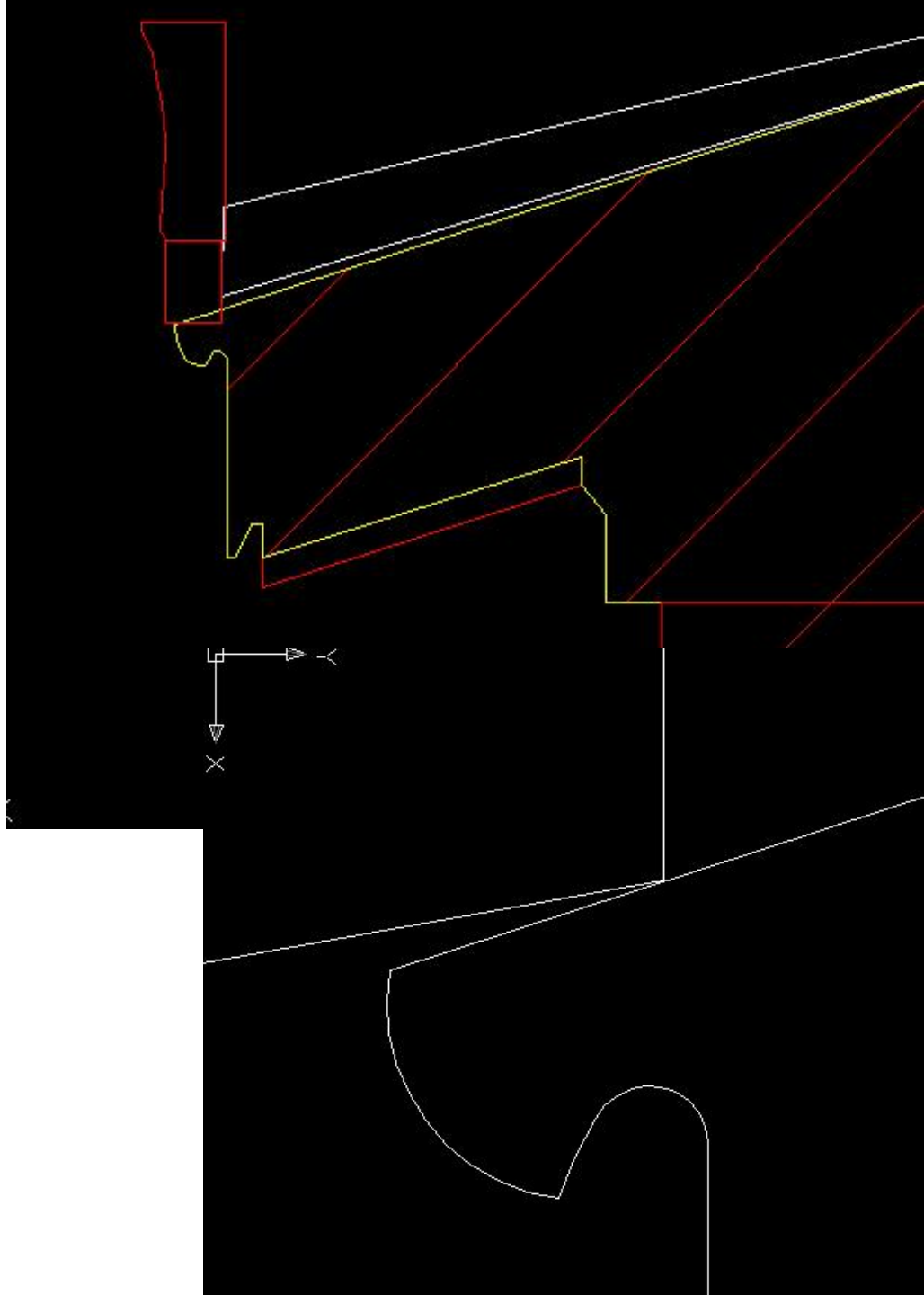
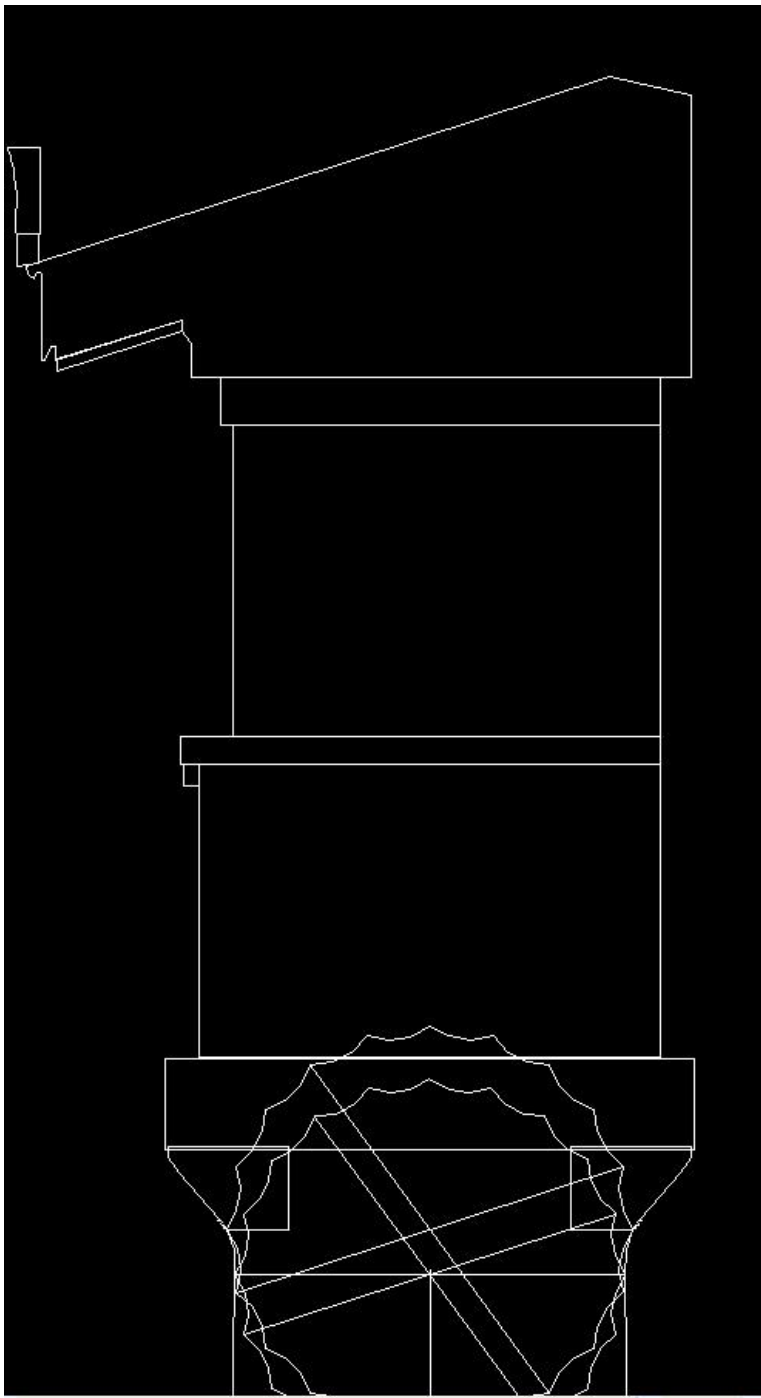

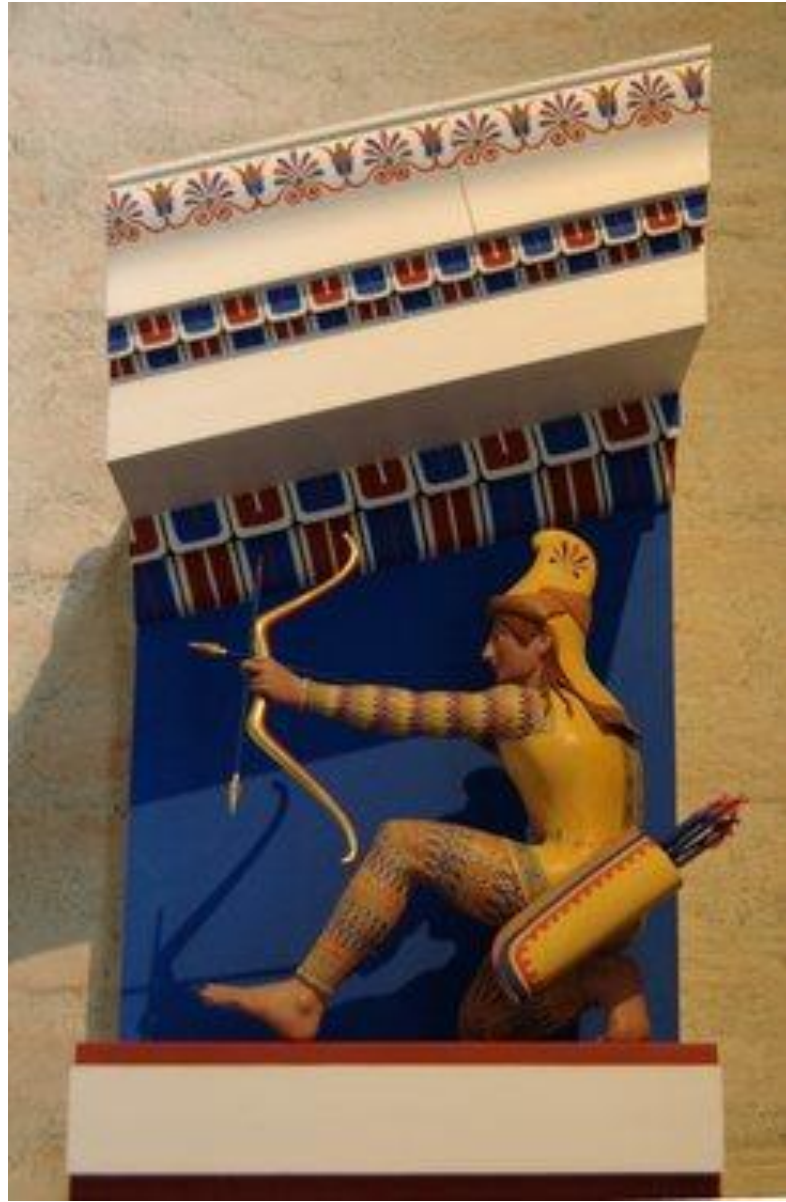



ΤΟ
ΡΑΜΦΟΣ
ΔΙΩΧΝΕΙ
ΝΕΡΟ -
ΜΑΖΕΥΕΙ
ΣΚΙΑ









- CYMA RECTA
- ΚΥΜΑ
- ΚΟΙΛΟΚΥΡΤΟ ΚΥΜΑΤΙΟ
- ΣΙΓΜΟΕΙΔΕΣ
- CYMA REVERSA – ΑΝΑΣΤΡΟΦΟ
- HEART AND DART / ΚΑΡΔΙΑ ΚΑΙ ΛΟΓΧΗ
- **ΛΕΣΒΙΟ ΚΥΜΑΤΙΟ**







- ΟΥΟΛΟ
- ΑΣΤΡΑΓΑΛΟΣ
- ΩΟΝ ΜΕΤΑ ΛΟΓΧΗΣ
- **ΙΩΝΙΚΟ ΚΥΜΑΤΙΟ**



ΑΛΕΑ, ΤΕΓΕΑ







ΙΩΝΙΚΟ ΚΙΟΝΟΚΡΑΝΟ ΣΤΟ ΠΑΝΕΠΙΣΤΗΜΙΟ
ΑΘΗΝΩΝ

Ionic Capital



ΙΩΝΙΚΟ ΚΙΟΝΟΚΡΑΝΟ ΣΤΑ ΠΡΟΠΥΛΑΙΑ ΤΩΝ
ΑΘΗΝΩΝ. ΨΗΦΙΑΚΗ ΑΠΟΚΑΤΑΣΤΑΣΗ

- ΚΟΙΛΟΚΥΡΤΟ ΚΥΜΑΤΙΟ
- ΚΟΙΛΟ ΚΥΜΑΤΙΟ
ΤΕΤΑΡΤΟΚΥΚΛΙΚΗΣ ΔΙΑΤΟΜΗΣ
- ΡΑΜΦΟΣ
- ΙΩΝΙΚΟ ΚΥΜΑΤΙΟ
- ΑΣΤΡΑΓΑΛΟΣ
- ΤΟΡΟΣ
- ΣΚΟΤΙΑ / ΤΡΟΧΙΛΟΣ

ΕΙΔΗ ΚΥΜΑΤΙΩΝ

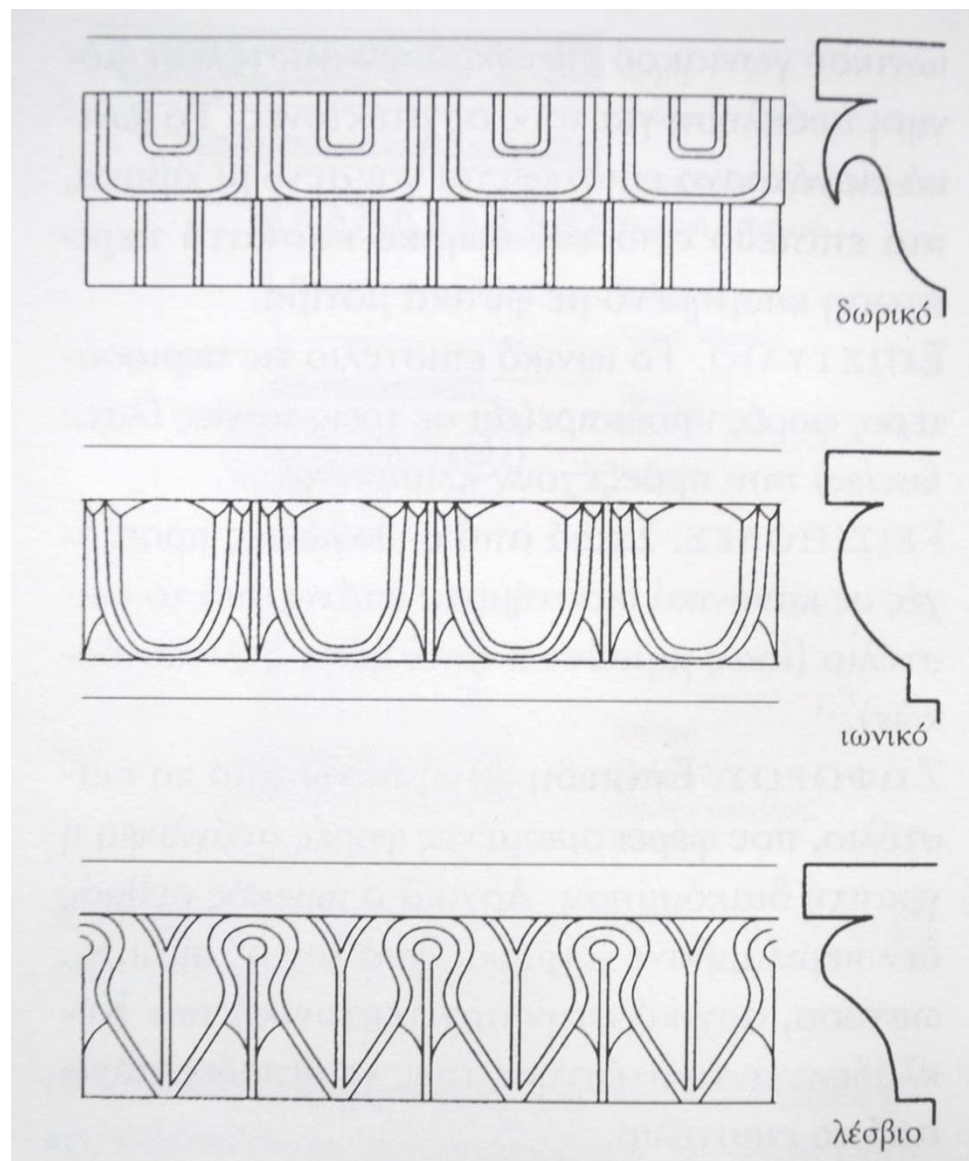

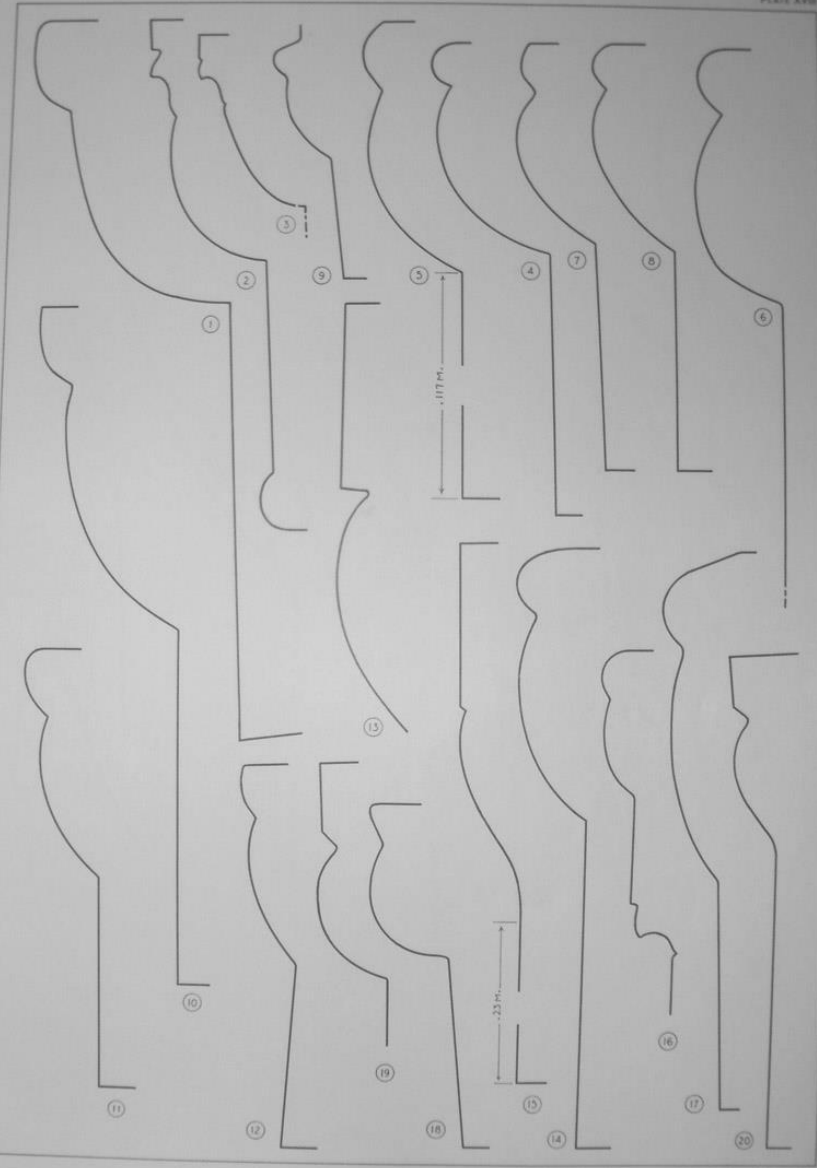

OVULO VII CORINTHIAN SIMA
SIXTH CENTURY

FIFTH AND FOURTH CENTURIES

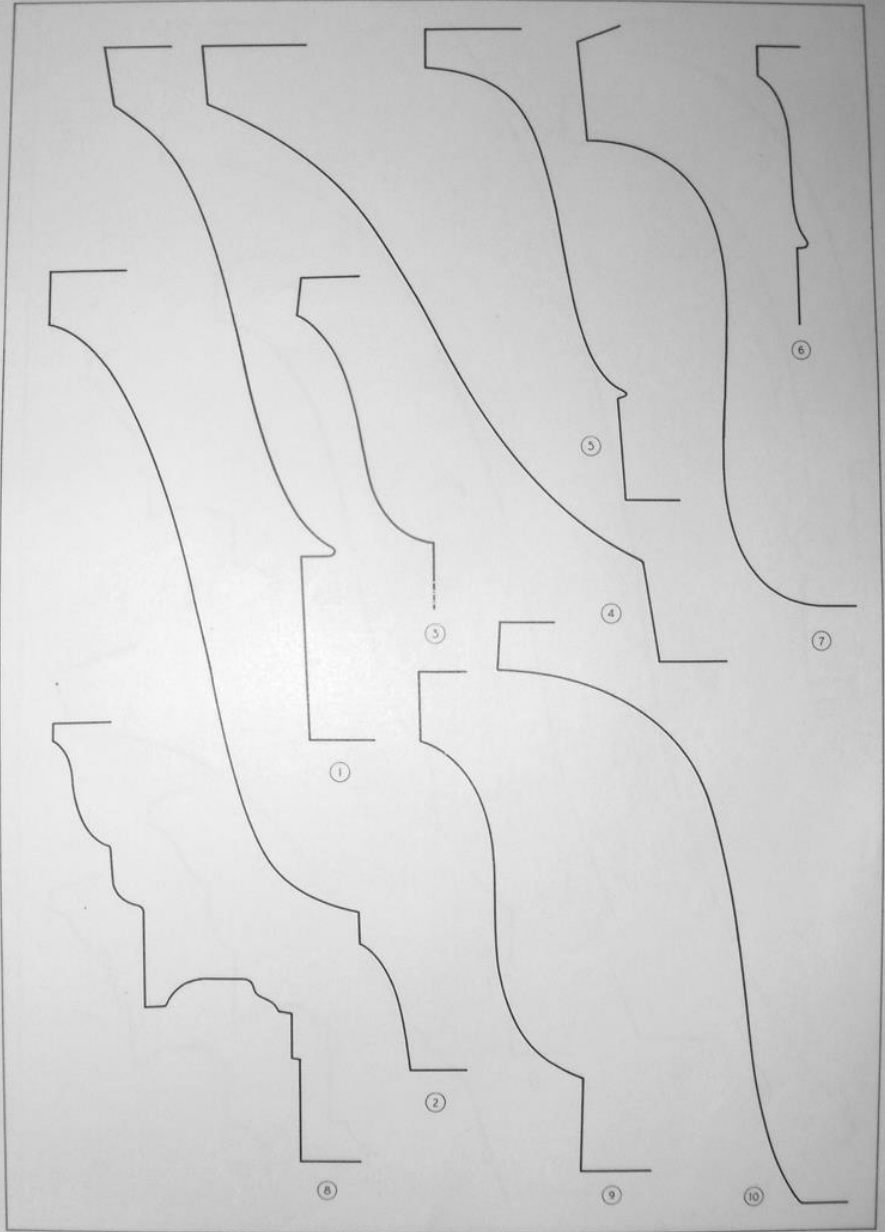

CYMA RECTA II SIMA
FIFTH AND FOURTH CENTURIES



ΛΕΟΝΤΟΚΕ ΦΑΛΕΣ

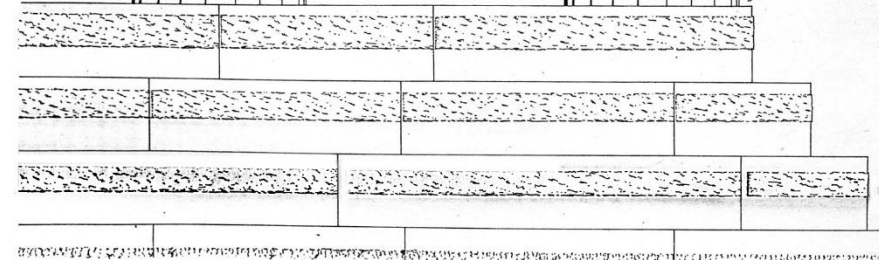
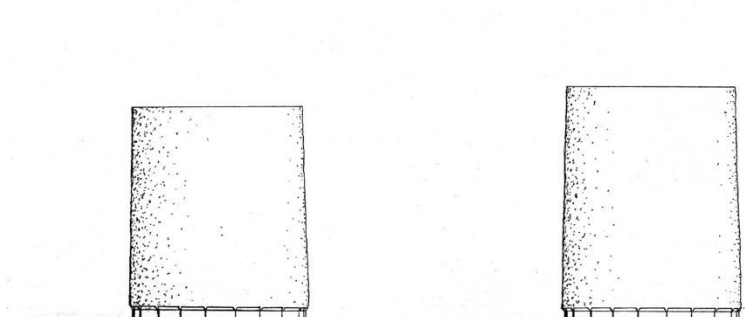
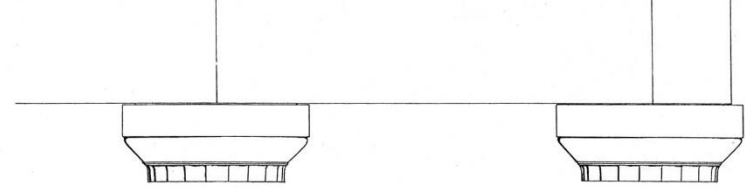
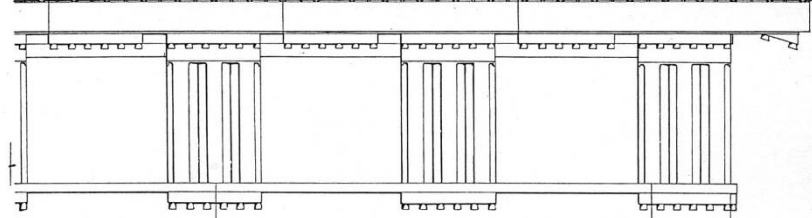
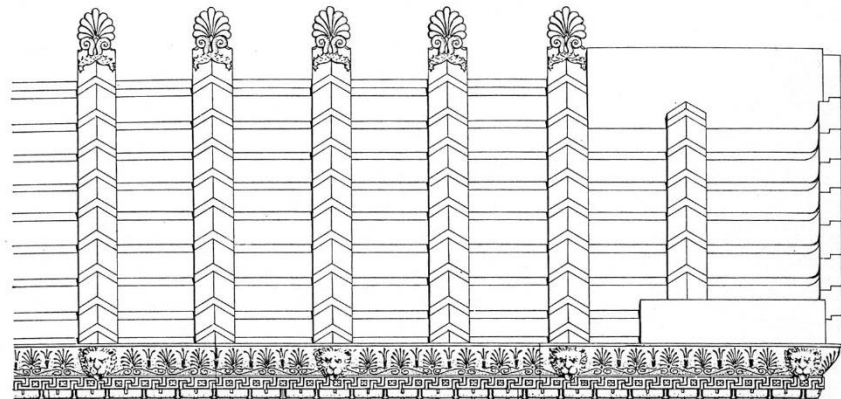

THE AGORA OF GYTHEION

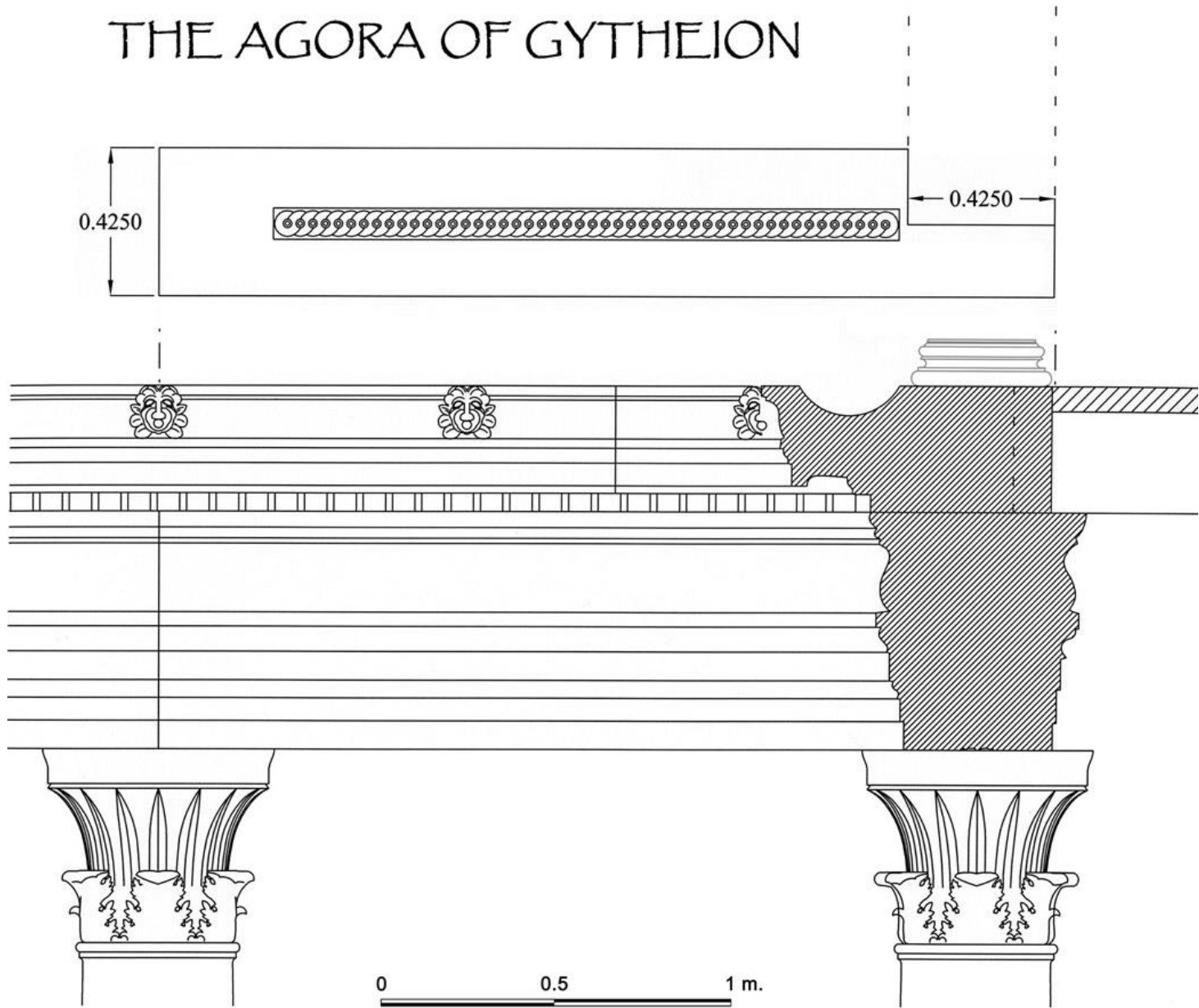











Reims



