

# THE THEATER

- THEATERS ABSORBED RECOURCES DURING THE 4<sup>TH</sup> CENTURY BC
- THEATERS AND CITY WALLS BECOME THE EXPRESSION OF A CITY'S INDEPENDENCE
- THEY DO NOT APPEAR IN NON DEMOCRATIC CITIES
- CEREMONIAL THEATERS

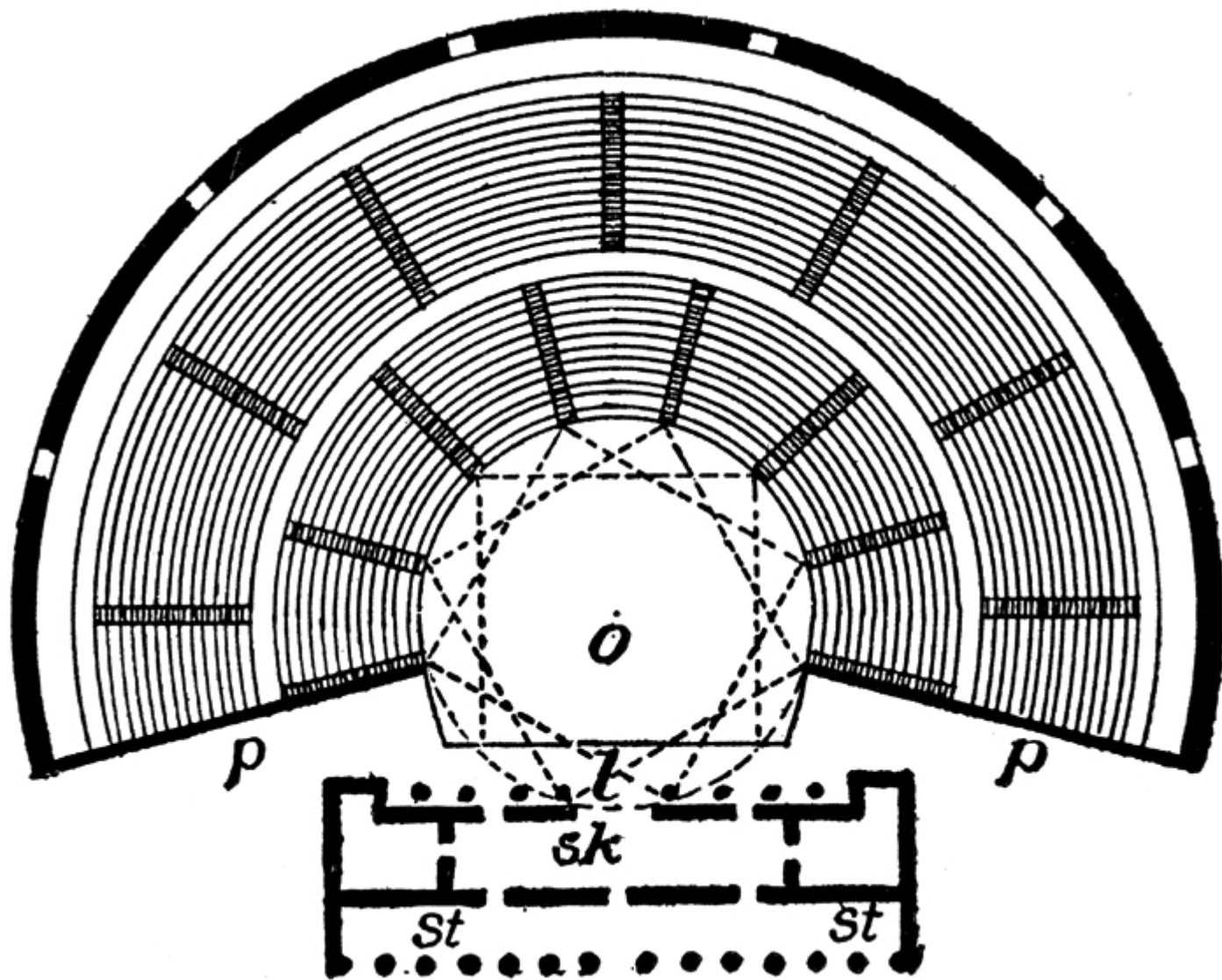

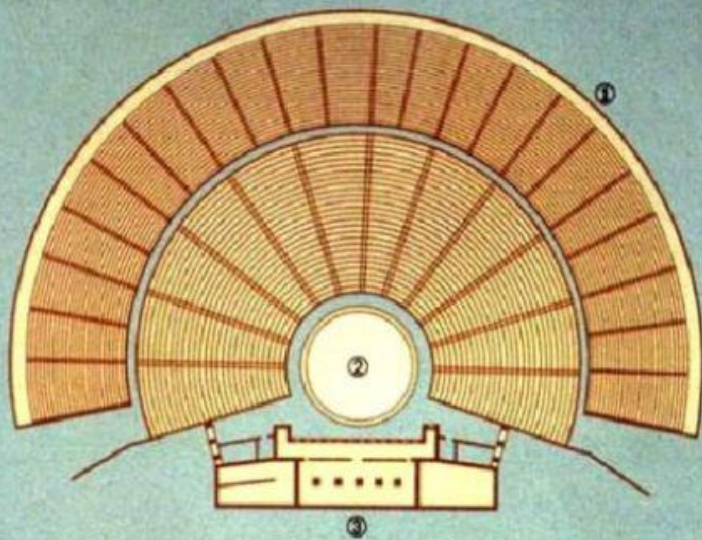

- ① Cavea
- ② Orchestra
- ③ Scena

- ❶ Koilon (cavea)
- ❷ Orchestra
- ❸ Schené (edificio scenico)
- ❹ Proedria
- ❺ Proskenion (palcoscenico)
- ❻ Pinakes (scene dipinte)
- ❼ Thyromata

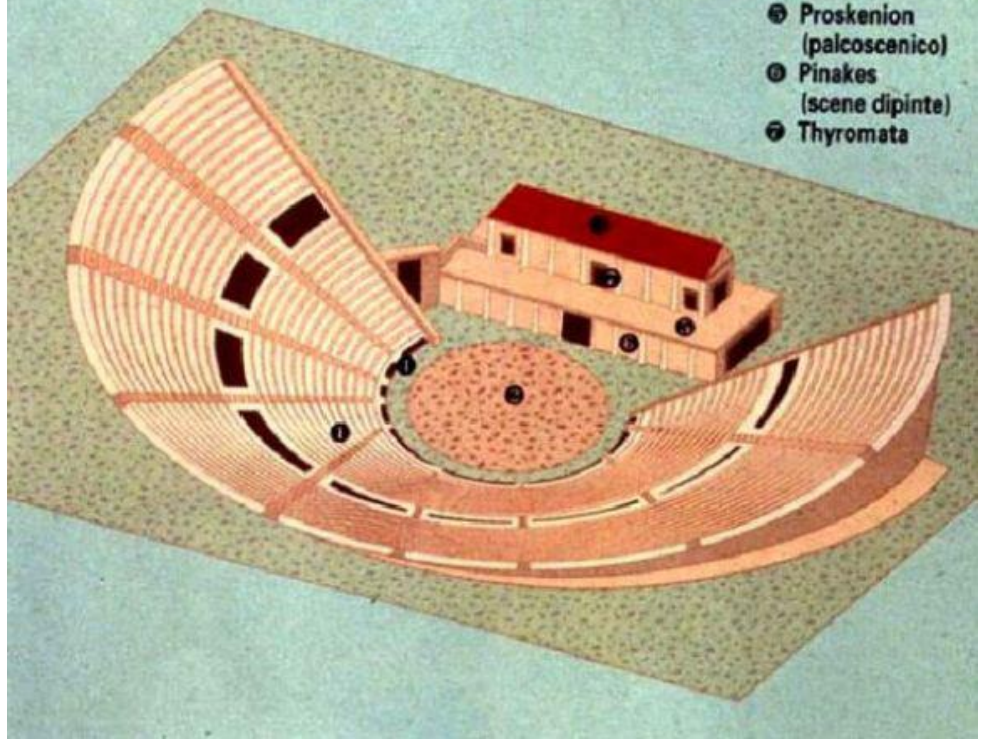

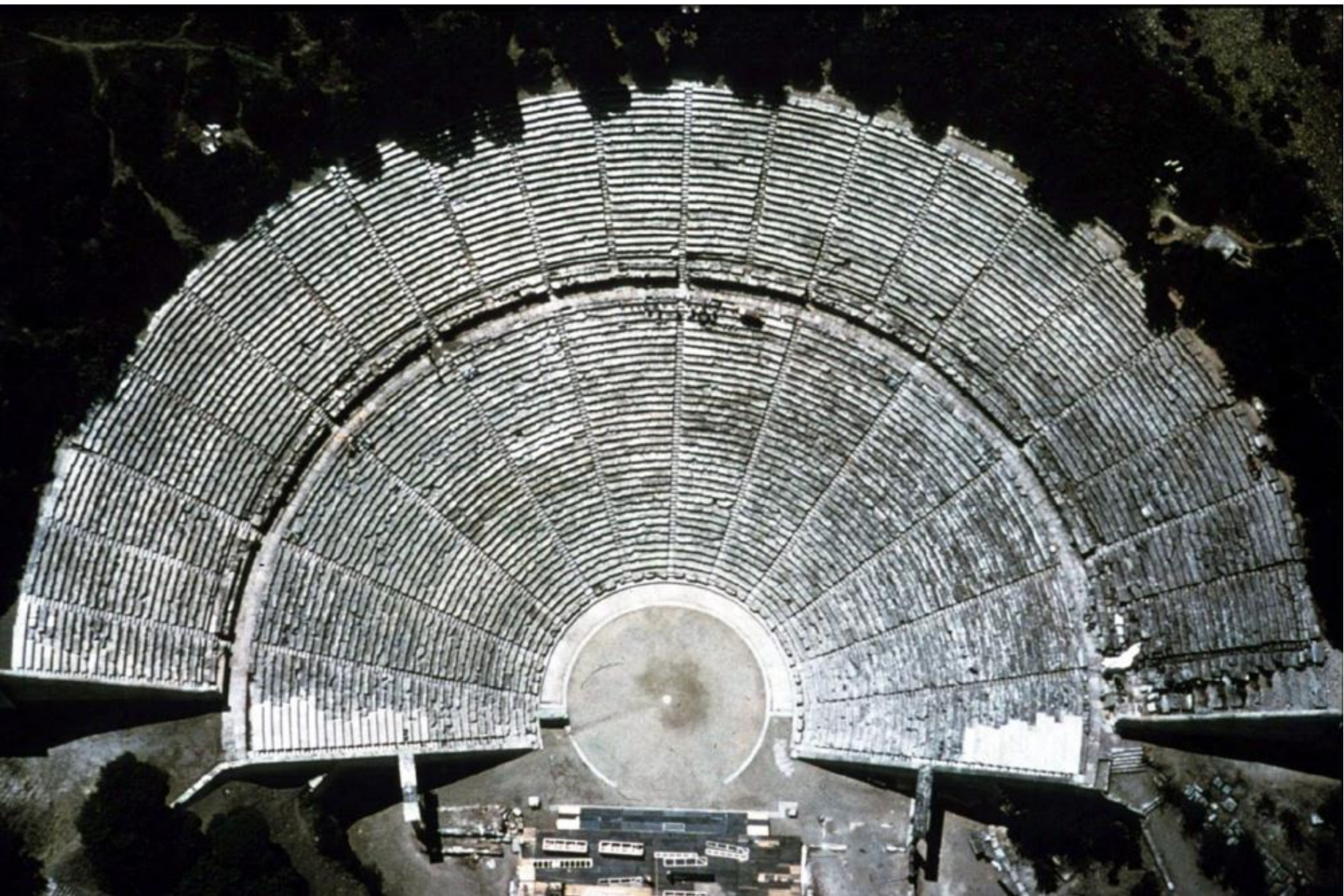

# THE ROMAN THEATER

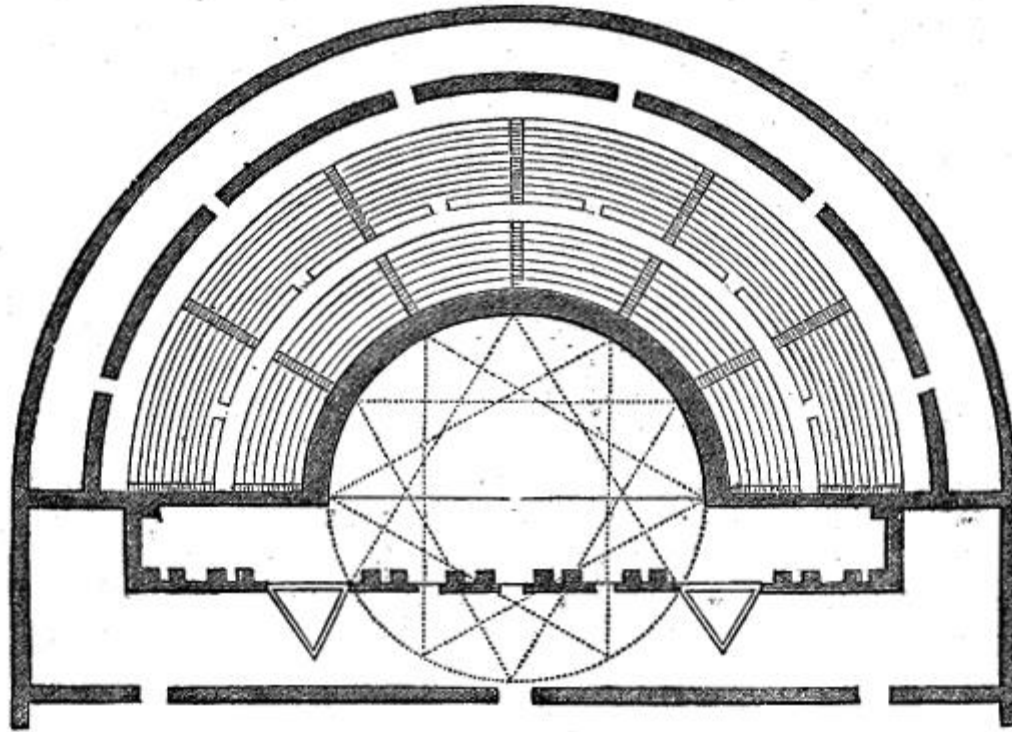

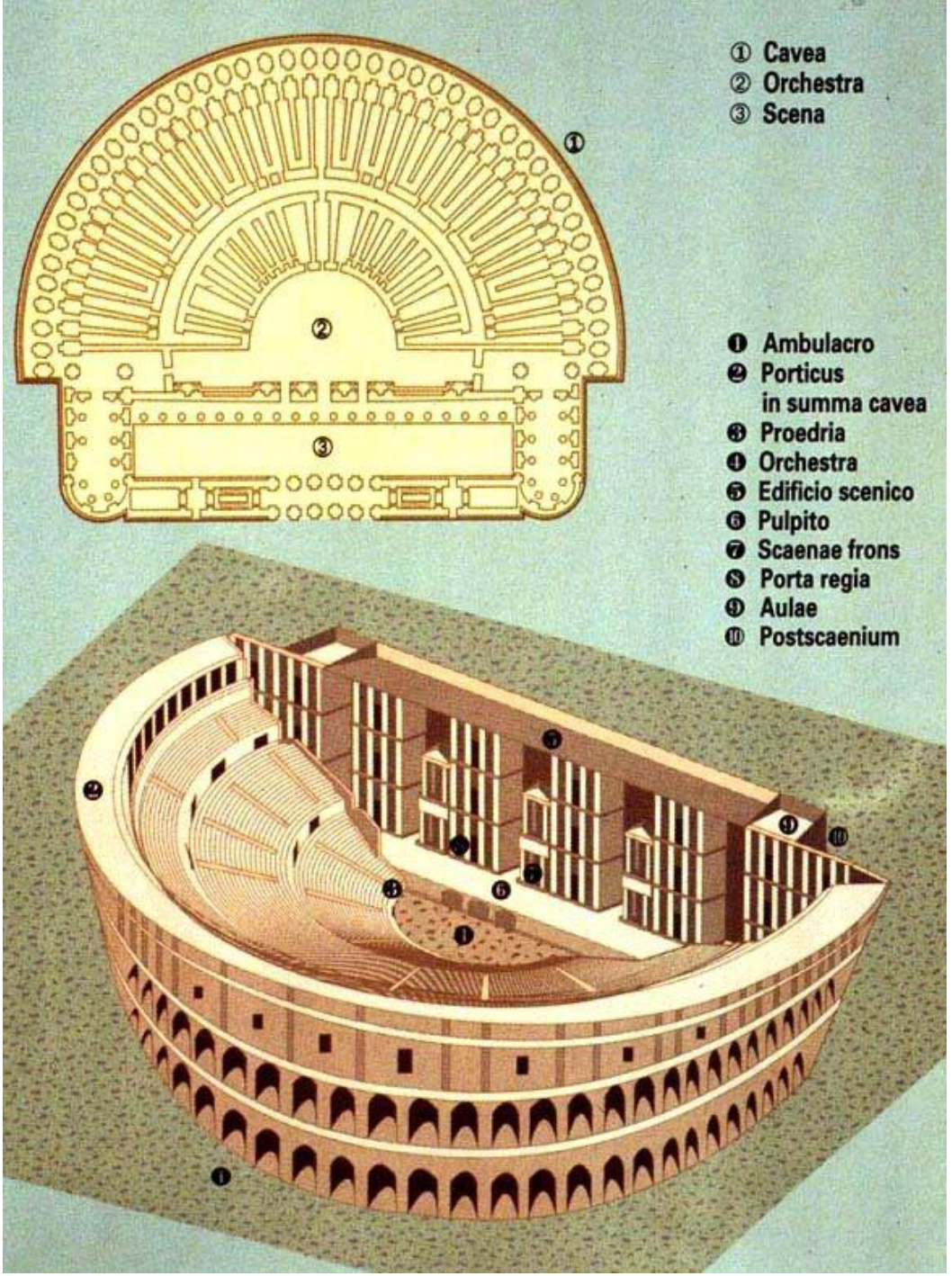

- ① Cavea
- ② Orchestra
- ③ Scena

- ① Ambulacro
- ② Porticus in summa cavea
- ③ Proedria
- ④ Orchestra
- ⑤ Edificio scenico
- ⑥ Pulpito
- ⑦ Scaenae frons
- ⑧ Porta regia
- ⑨ Aulae
- ⑩ Postscaenium

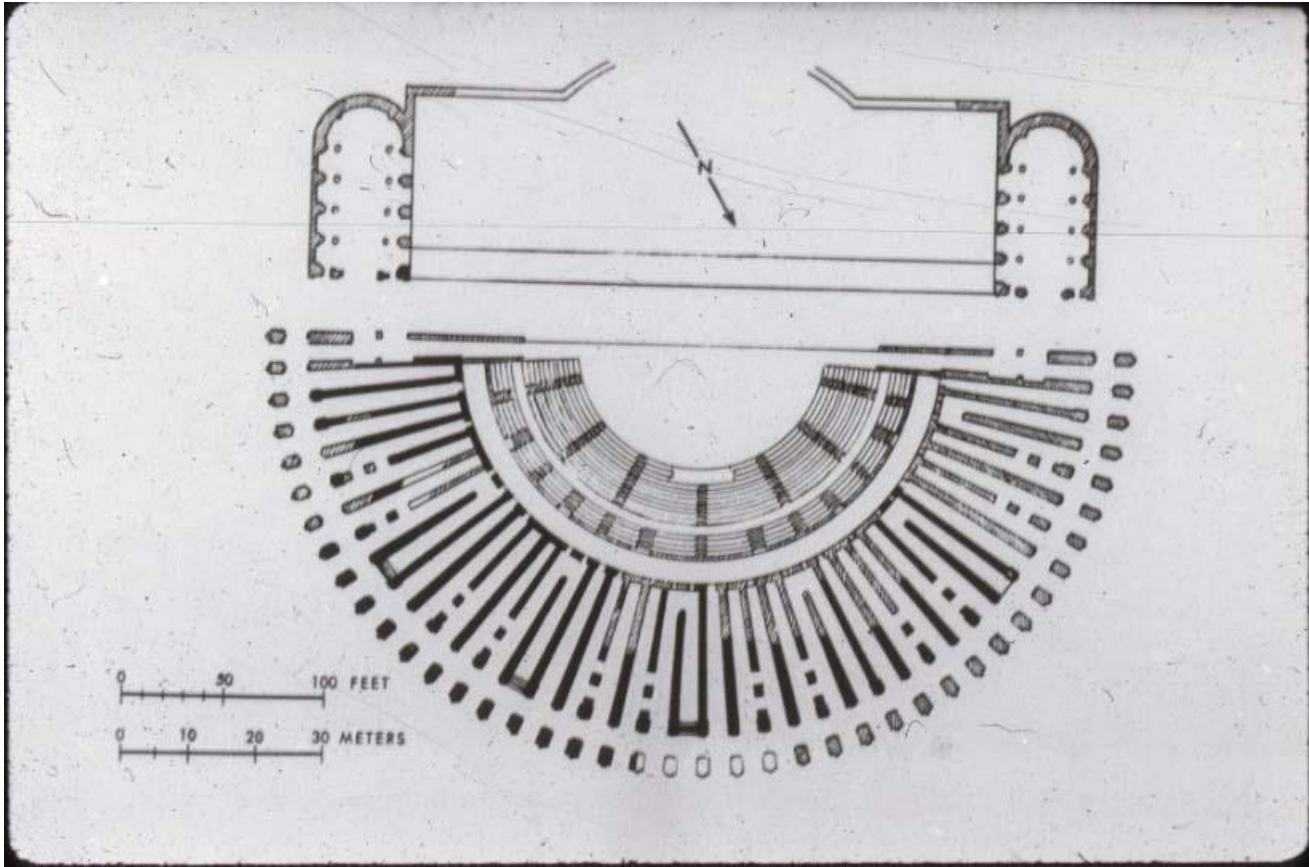

# ORIGINS OF THE ARCHAIC AND CLASSICAL THEATERS

- MISSING ARCHAEOLOGICAL EVIDENCE
- VERY FEW REPRESENTATIONS ON ART



*ἄθλα ἐπὶ Πατρόκλῳ, 580-570 π.Χ.*



# WOODEN SCENE

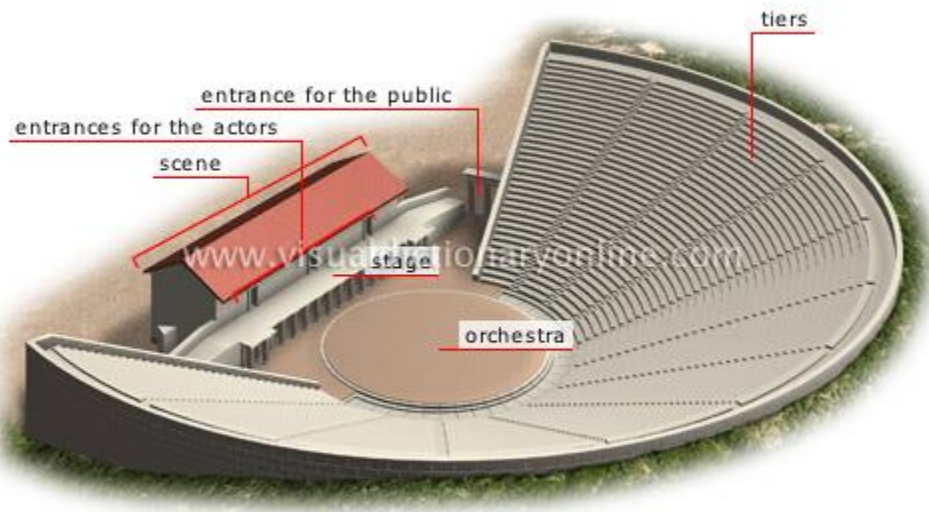

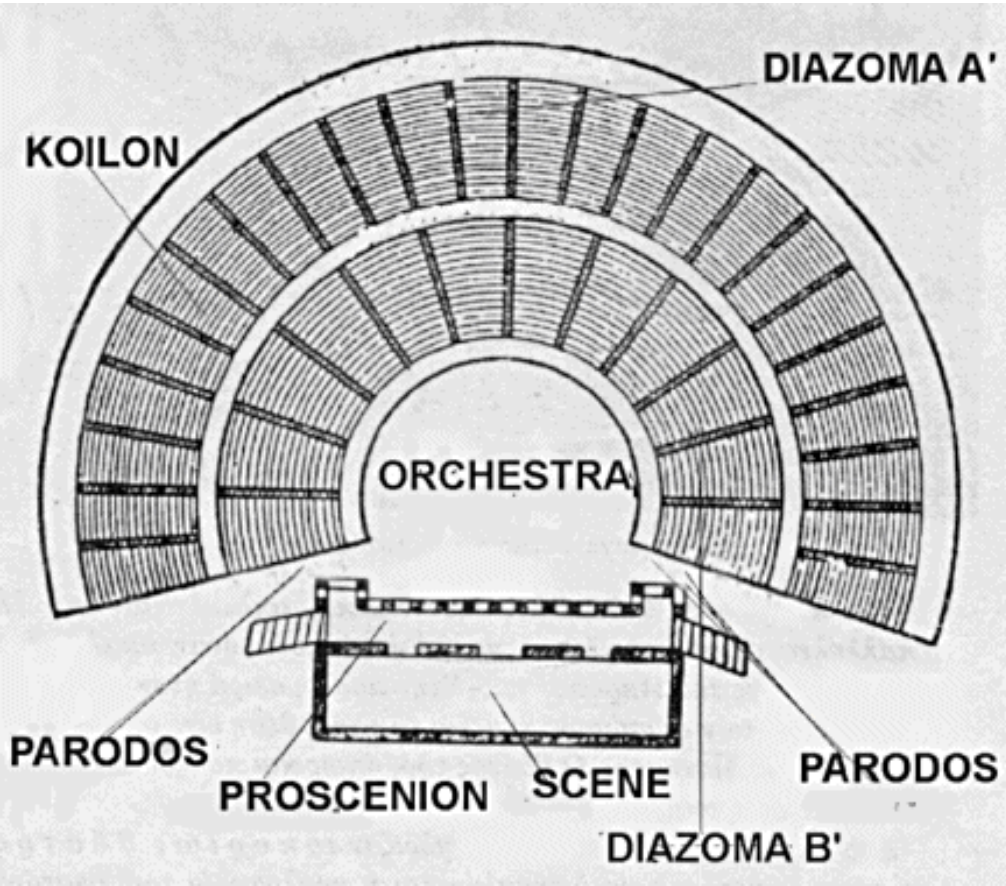

Anti, C, 1947 *Teatri greci arcaici*

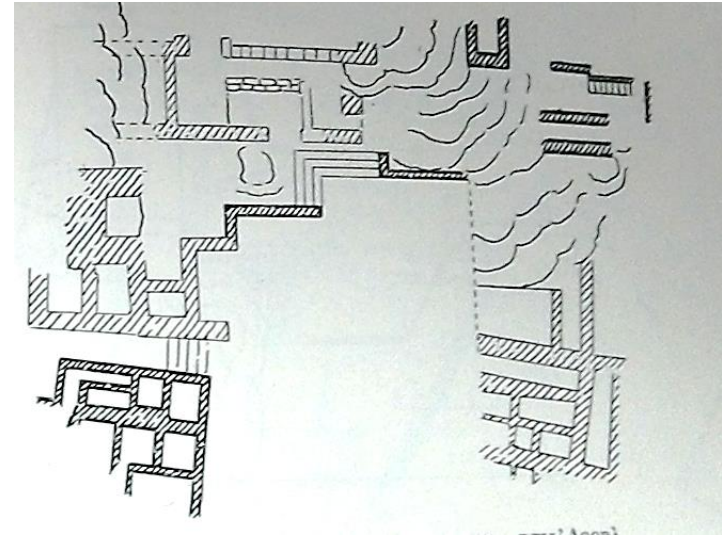
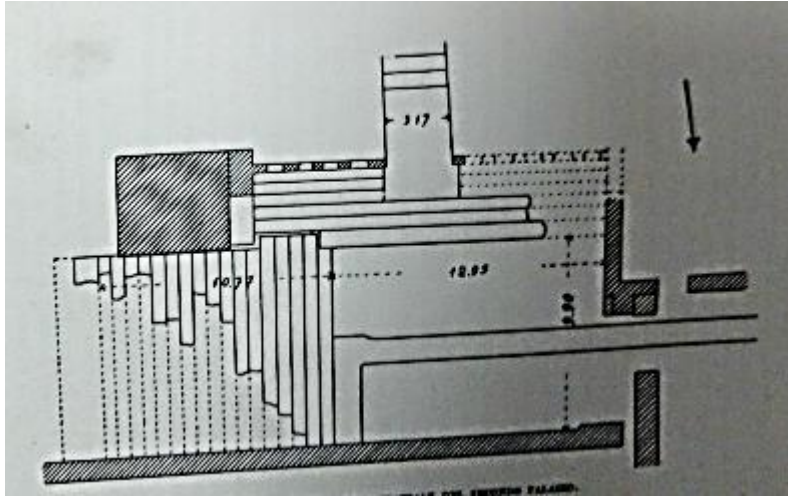

GOURNIA



KNOSSOS

Anti, C, 1947 *Teatri greci arcaici*

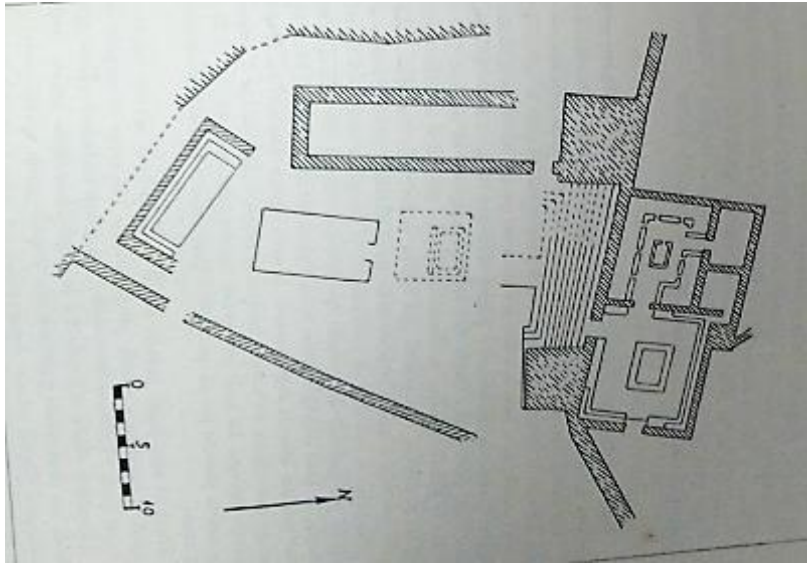

LATO

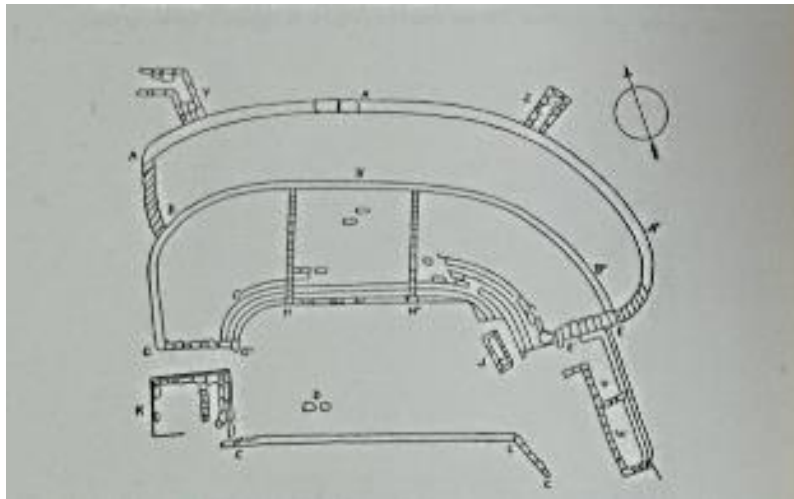

THORIKOS



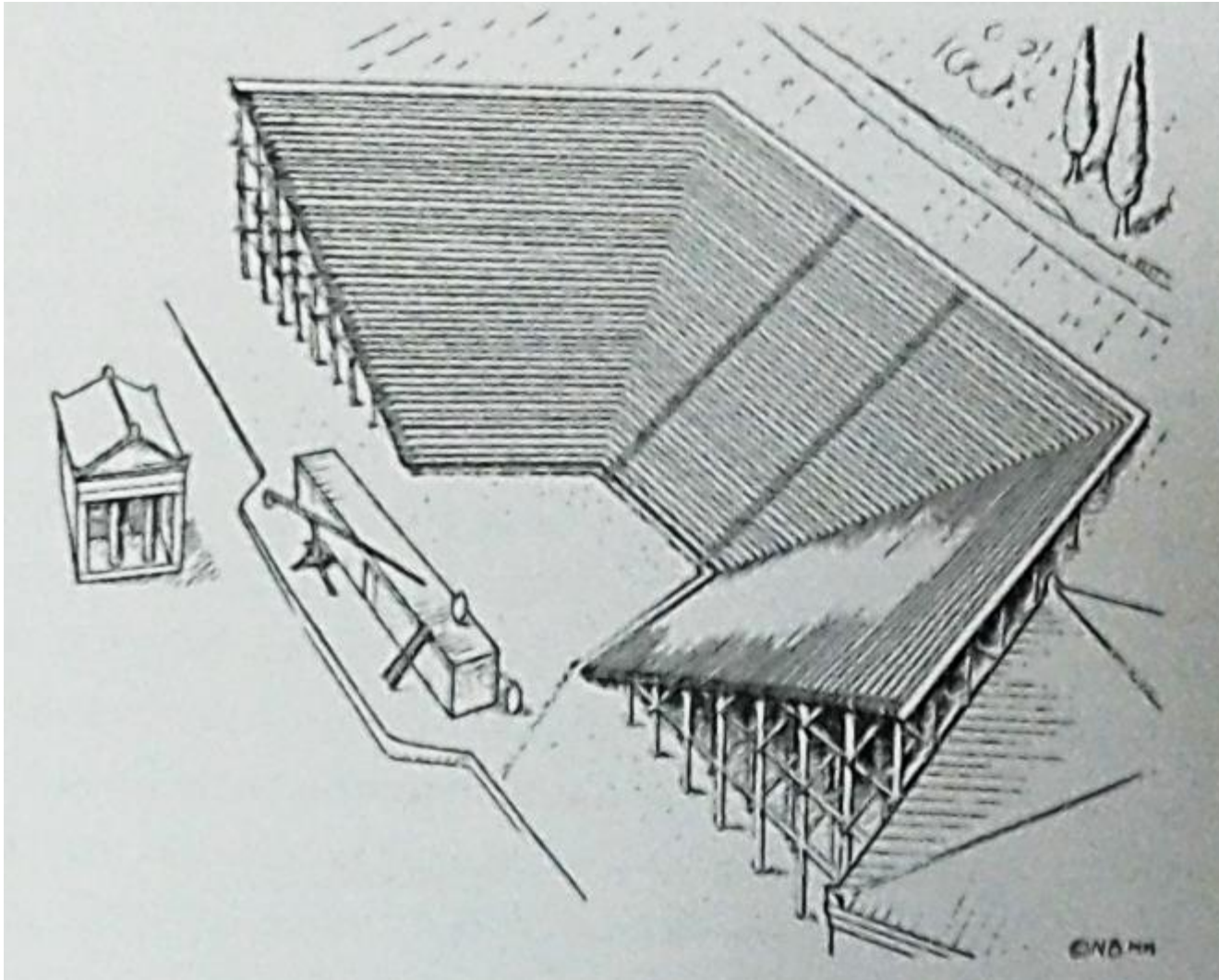

ATHENS: EARLY CLASSICAL PERIOD. THEATER AT PNYX

# THEATERS OF THE CLASSICAL PERIOD

NO STANDARD TYPOLOGY

A CAVEA ON A NATURAL SLOPE

STRAIGHT WOODEN SEATS

ORCHESTRA IS RECTANGULAR, ROUND OR OBLONG

## 4<sup>TH</sup> CENT. – HELLENISTIC PERIOD

- THEATERS SPREAD ALL OVER THE HELLADIC AREA
- CLEAR TYPOLOGY
- STONE, MONUMENTAL, STRUCTURES
- FOLLOW THE EVOLUTION OF TRAGEDY
- EMPHASIS ON THE SCENE

# THORIKOS

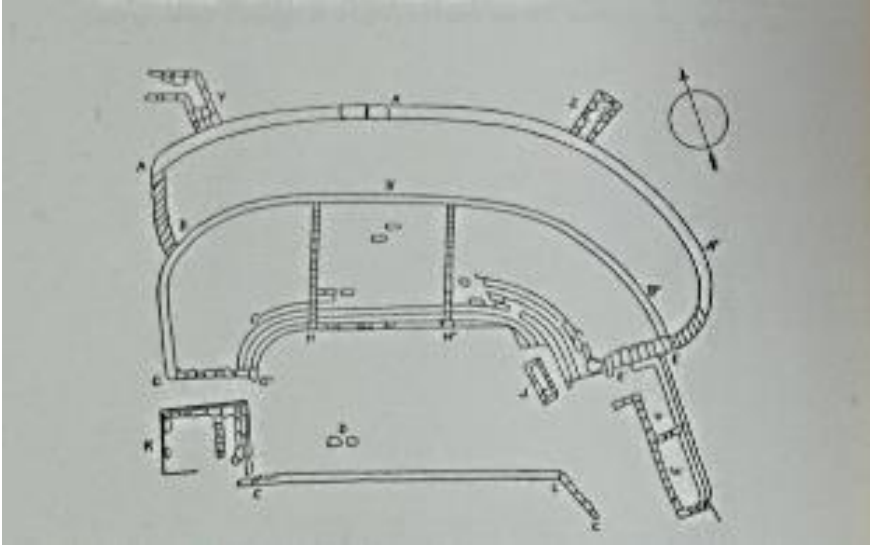



# T TYPOLOGY

Frederiksen, R. 2000. «The Greek Theatre. A Typical Building in the Urban Centre of the Polis?», in: T.H. Nielsen, *Even more Studies in the Ancient Greek Polis. Papers from the Copenhagen Polis Centre 6 (Historia Einzelschriften 162)* 65-124

# TYPE C. ATHENS. THEATER OF DIONYSOS 335-326 BC

*Fig. 4. Stylized version of type C  
(straight winged). Inspired from  
the theatre of Dionysos at  
Athens, the Lykourgan phase  
(Athens III).  
(R. Frederiksen)*

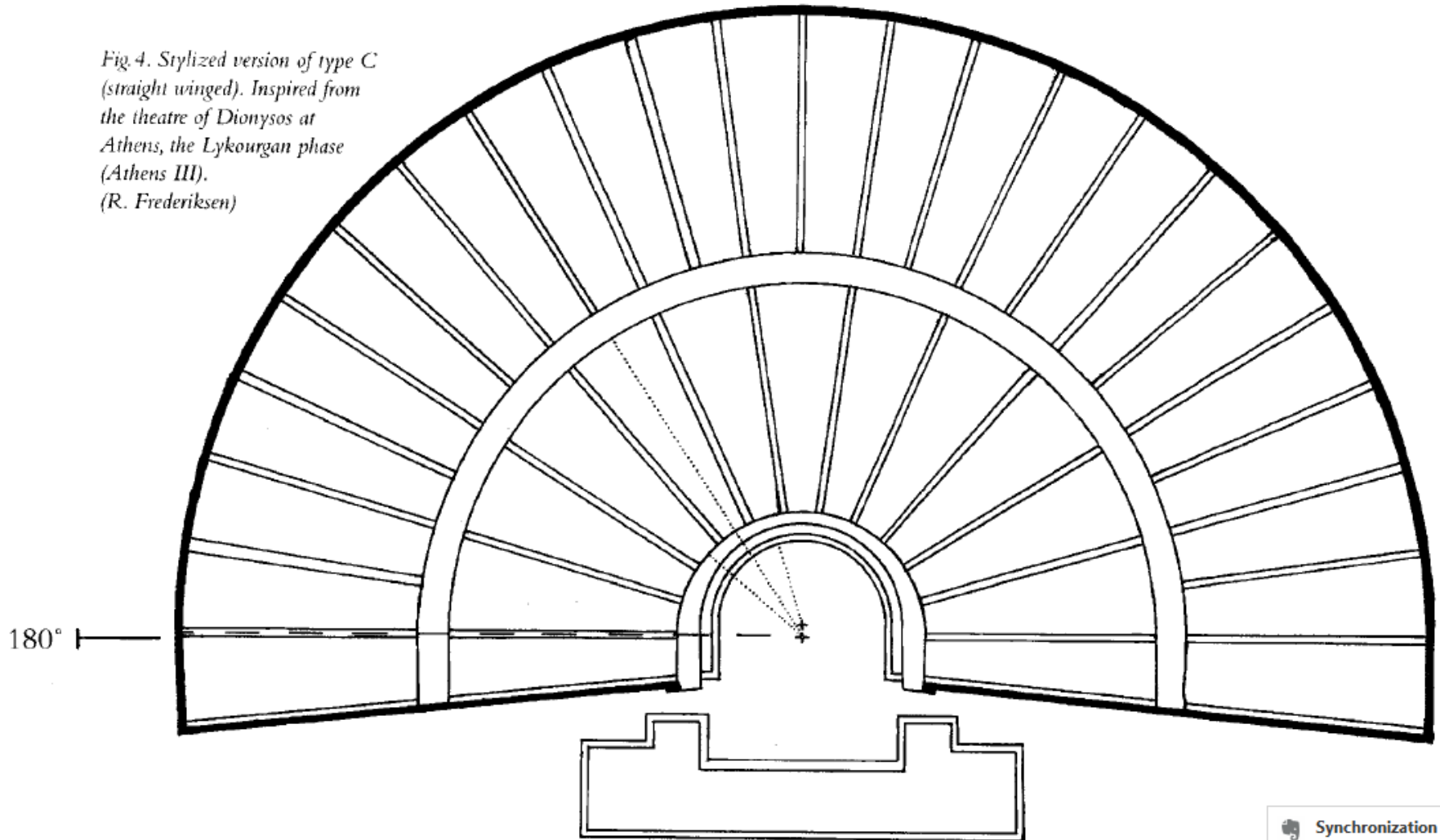

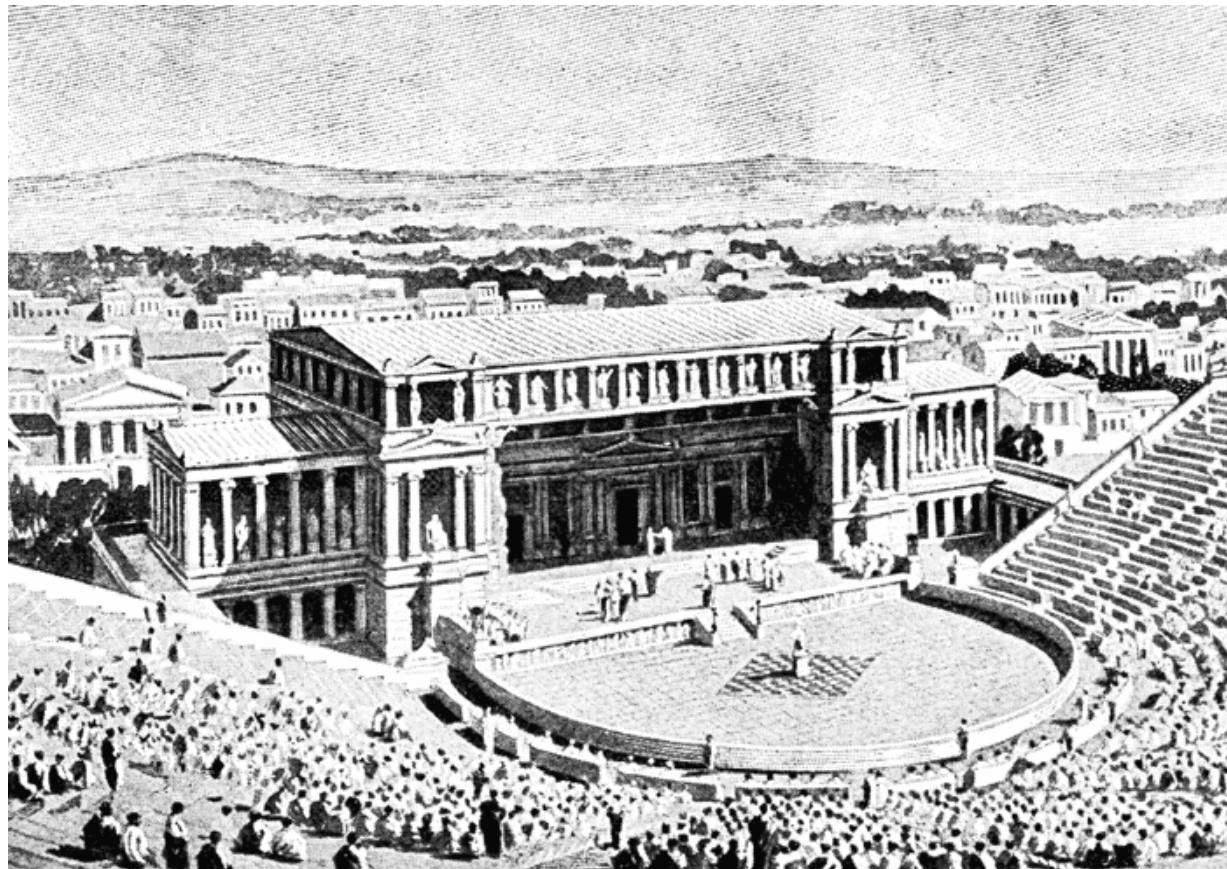

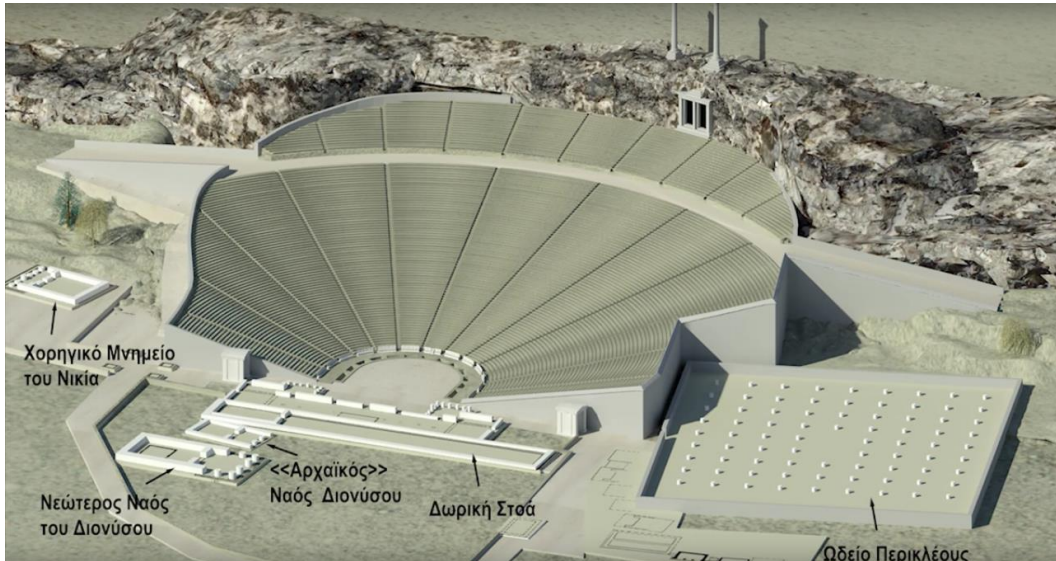
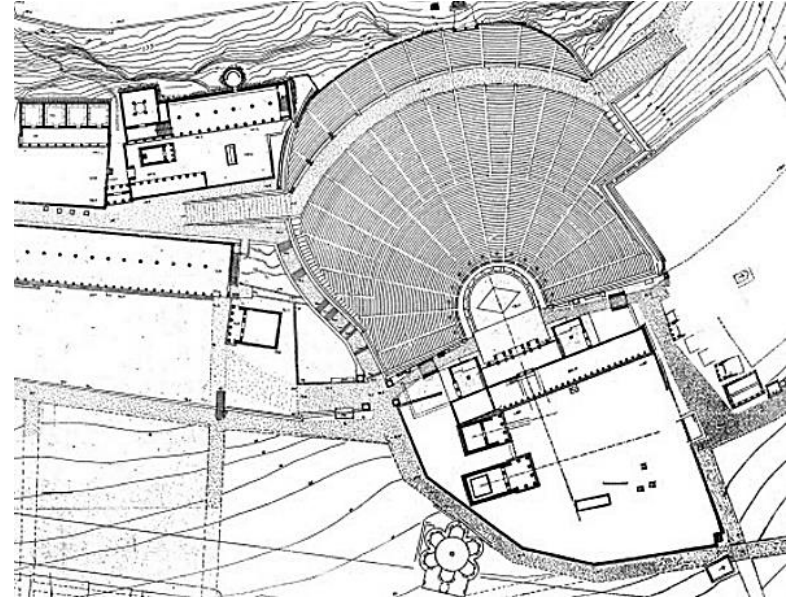

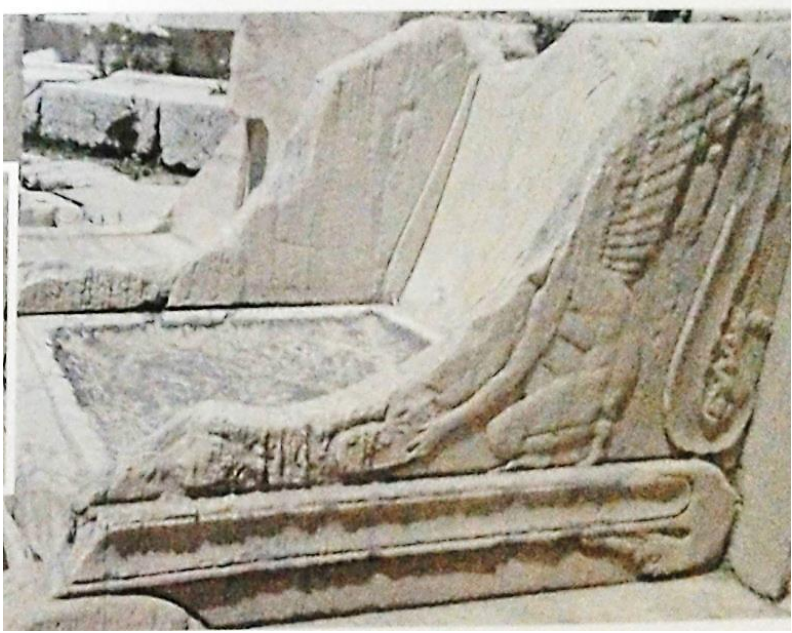

THRONE OF DIONYSOS' PRIEST



THRONE

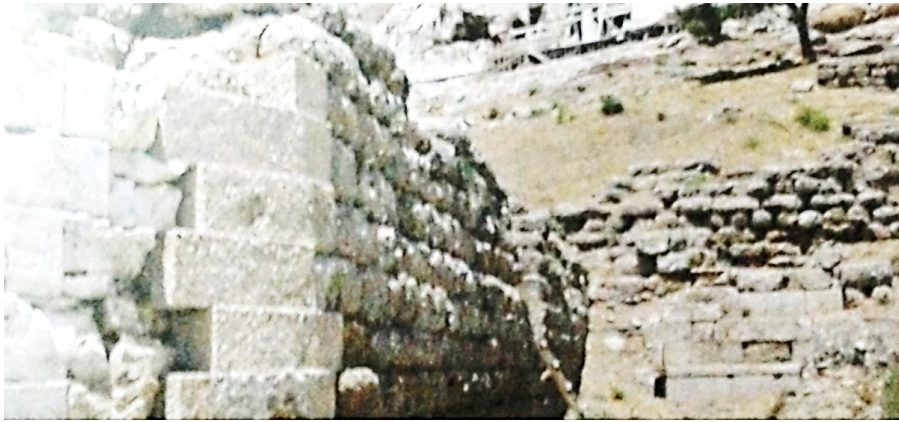

RETAINING WALLS



## PARASCENIA

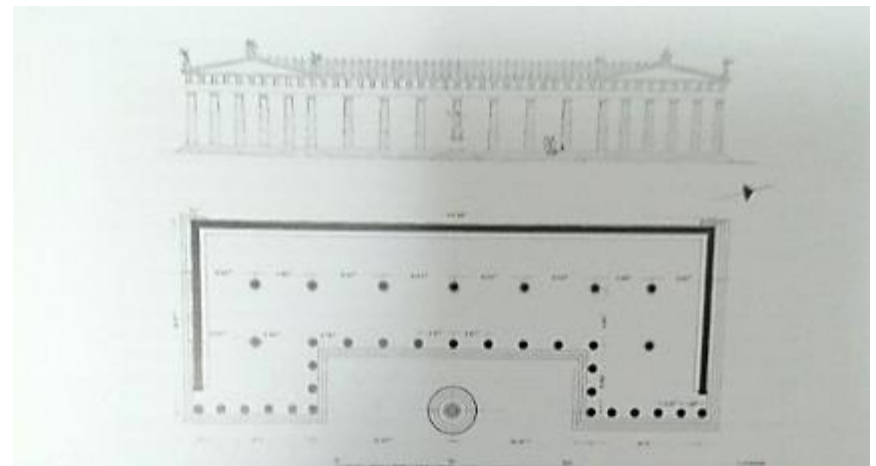
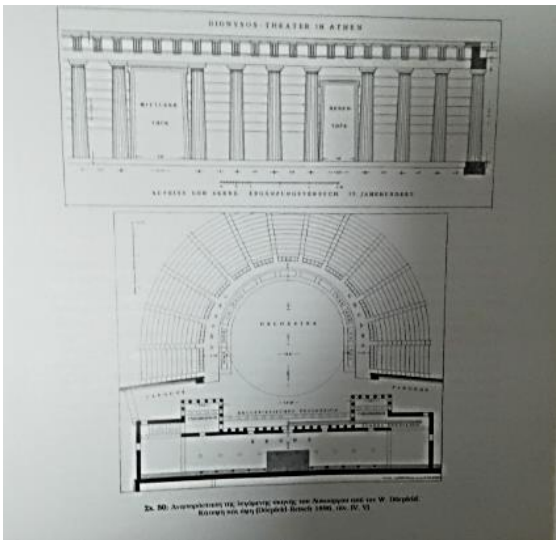

## STOA OF ZEUS, AGORA

# TYPE C

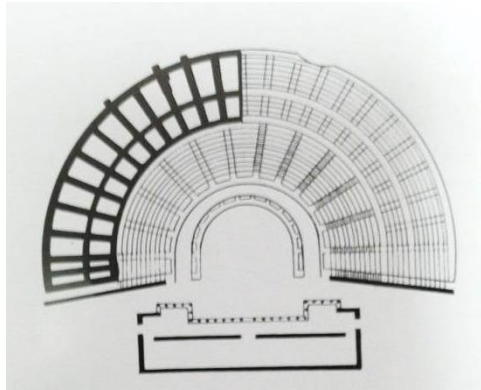
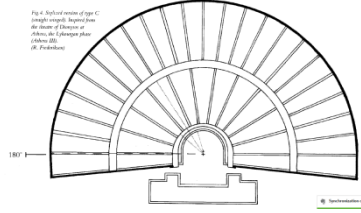

PIRAEUS

# ISTHMA

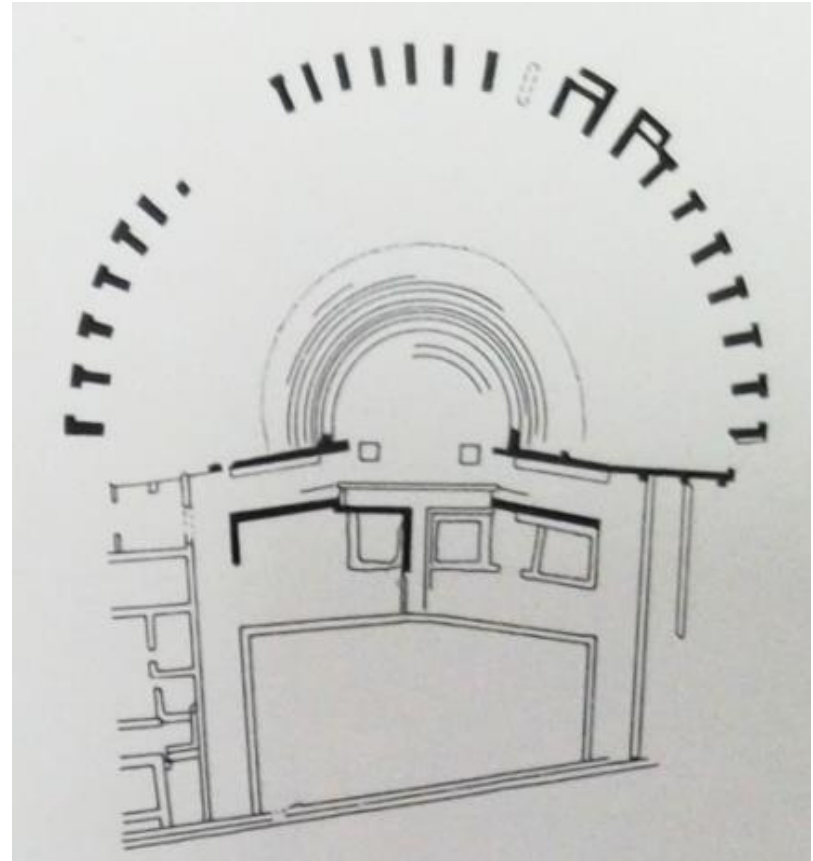



# TYPE E. EPIDAUROS

Fig. 5. Stylized version of type E  
(elliptical).  
(R. Frederiksen)

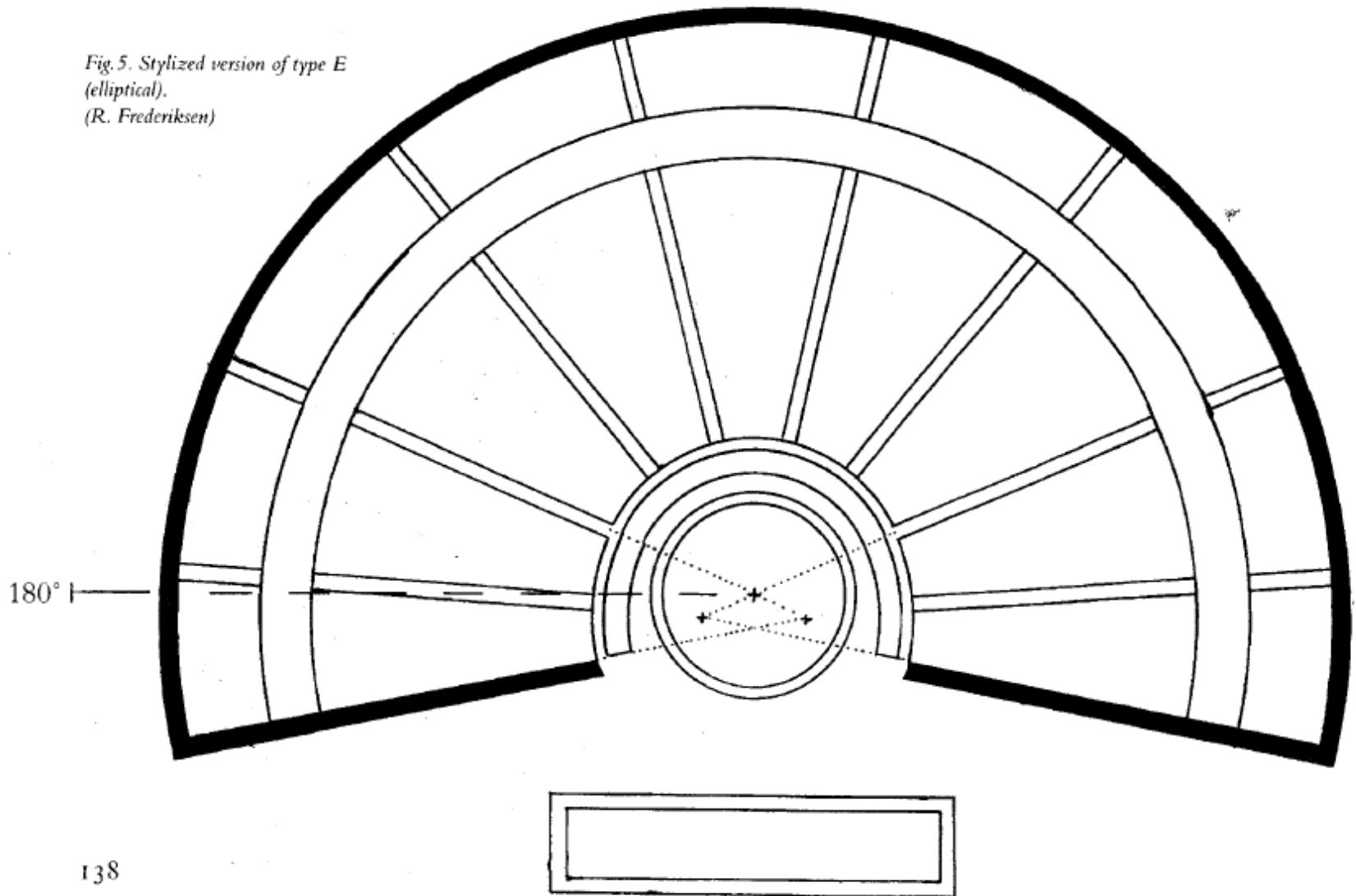





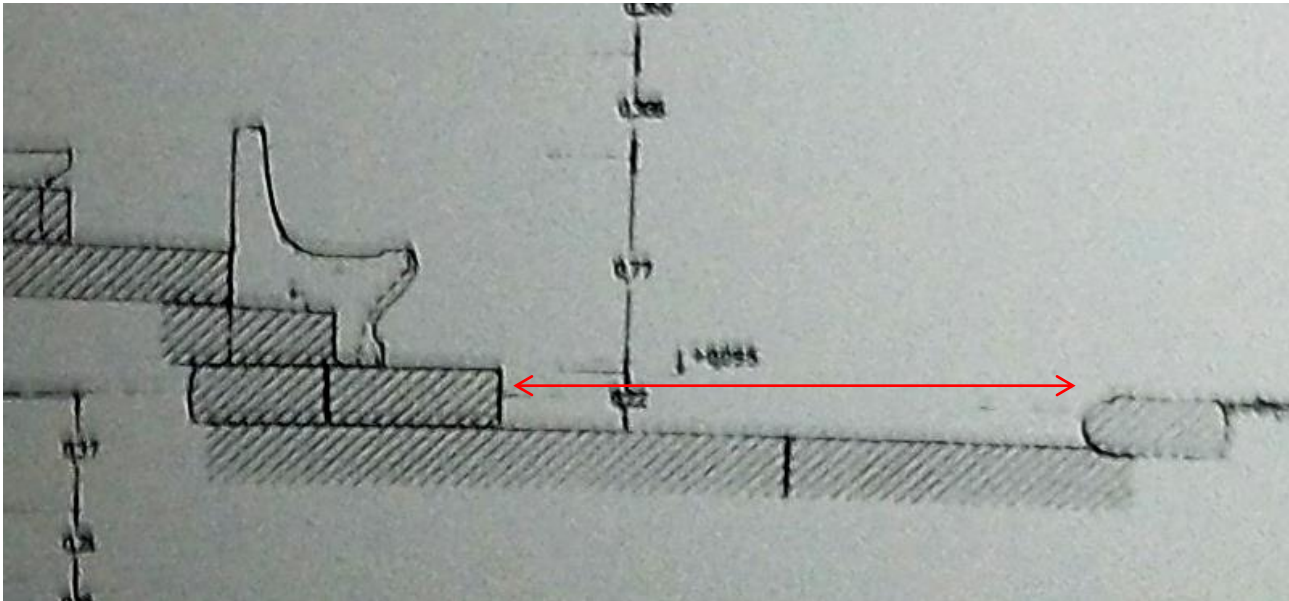

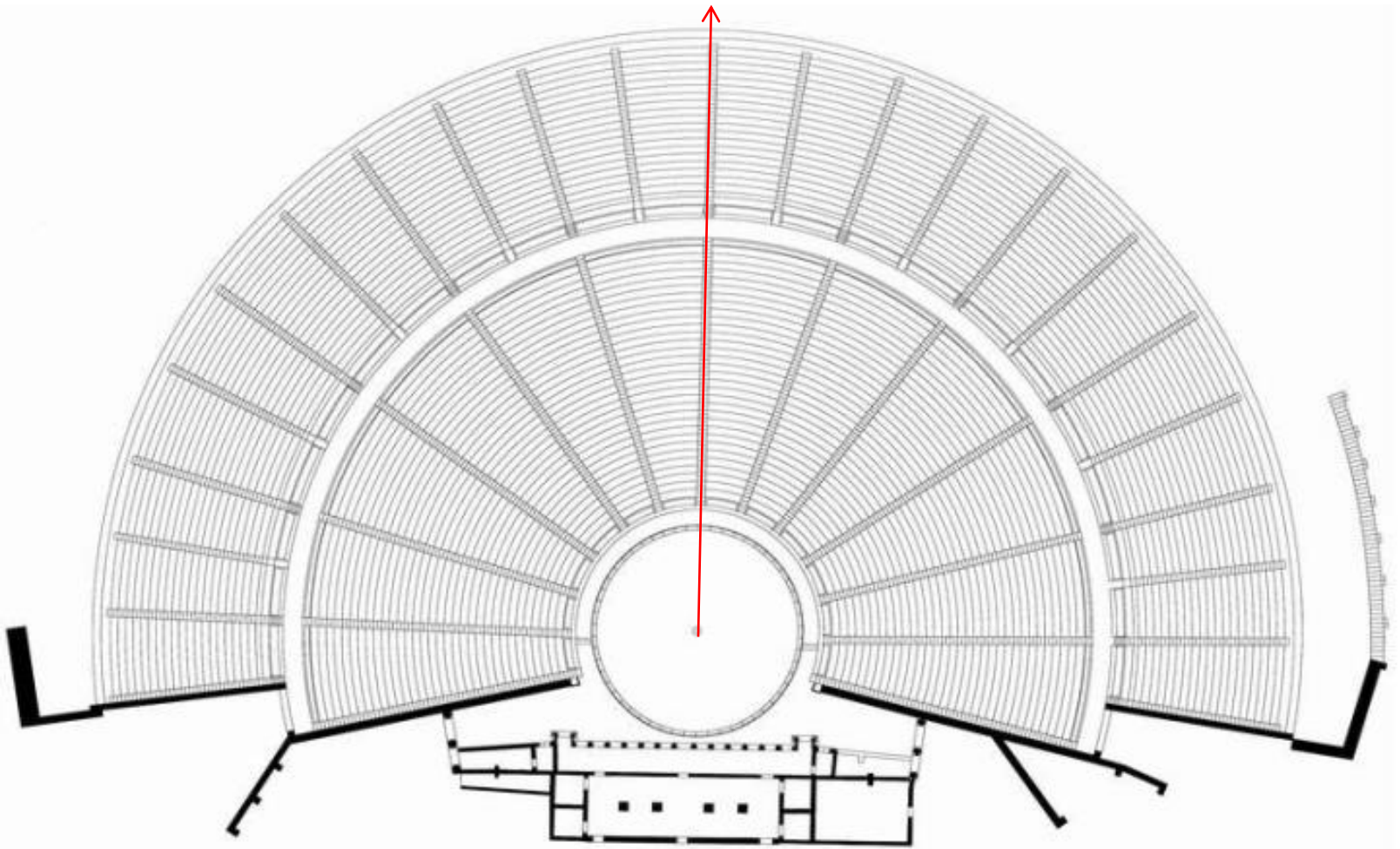

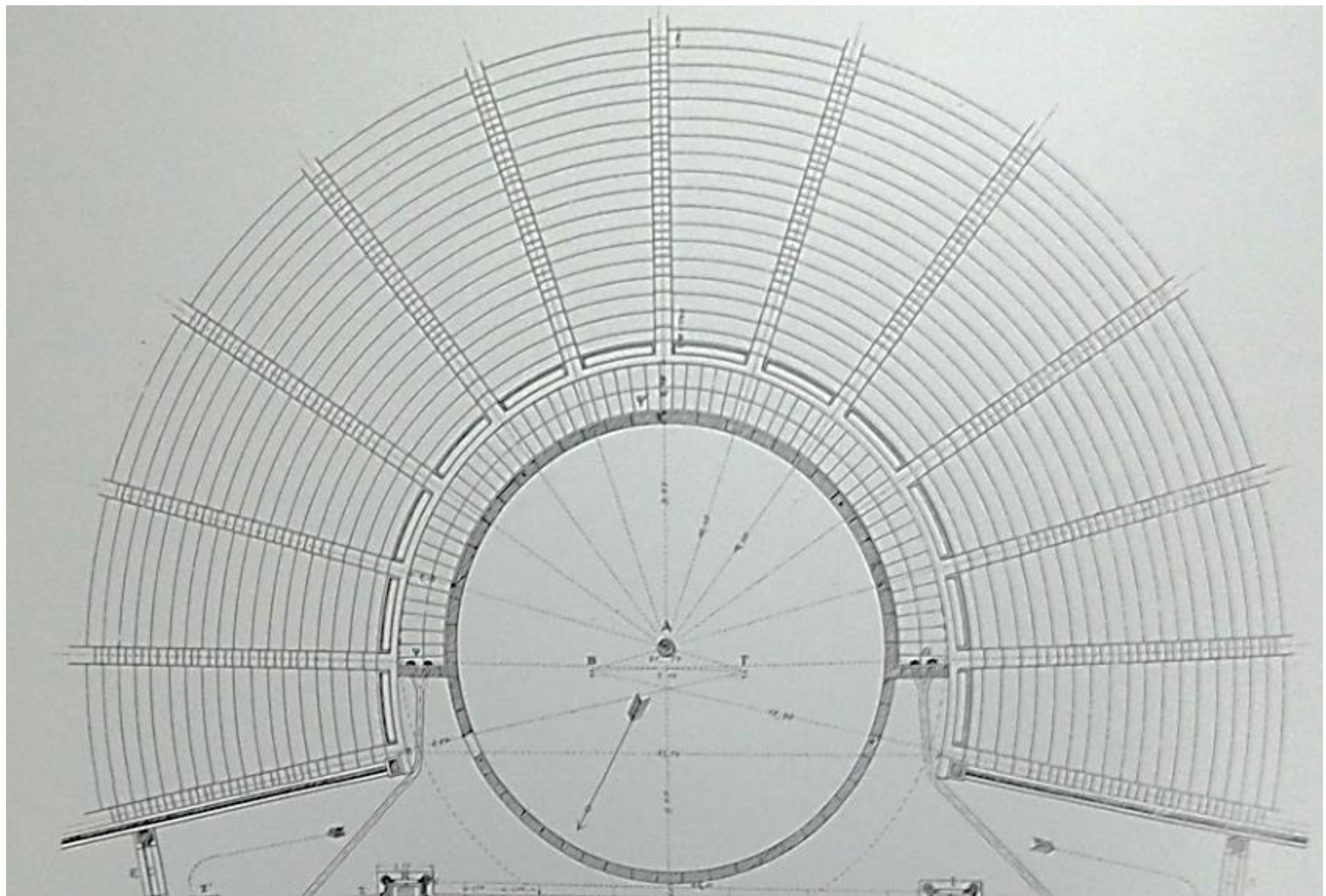

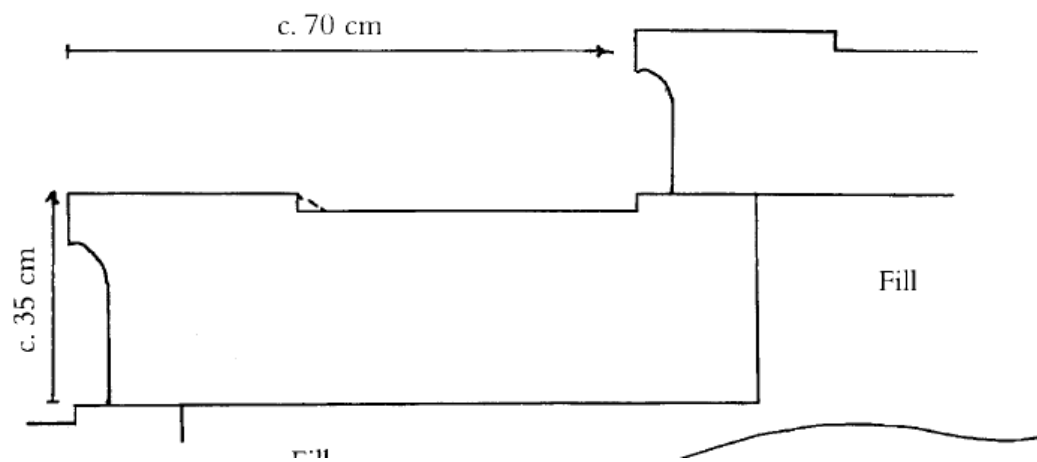

Εδώλια



# SCENE PROSCENIA PARASKENIA

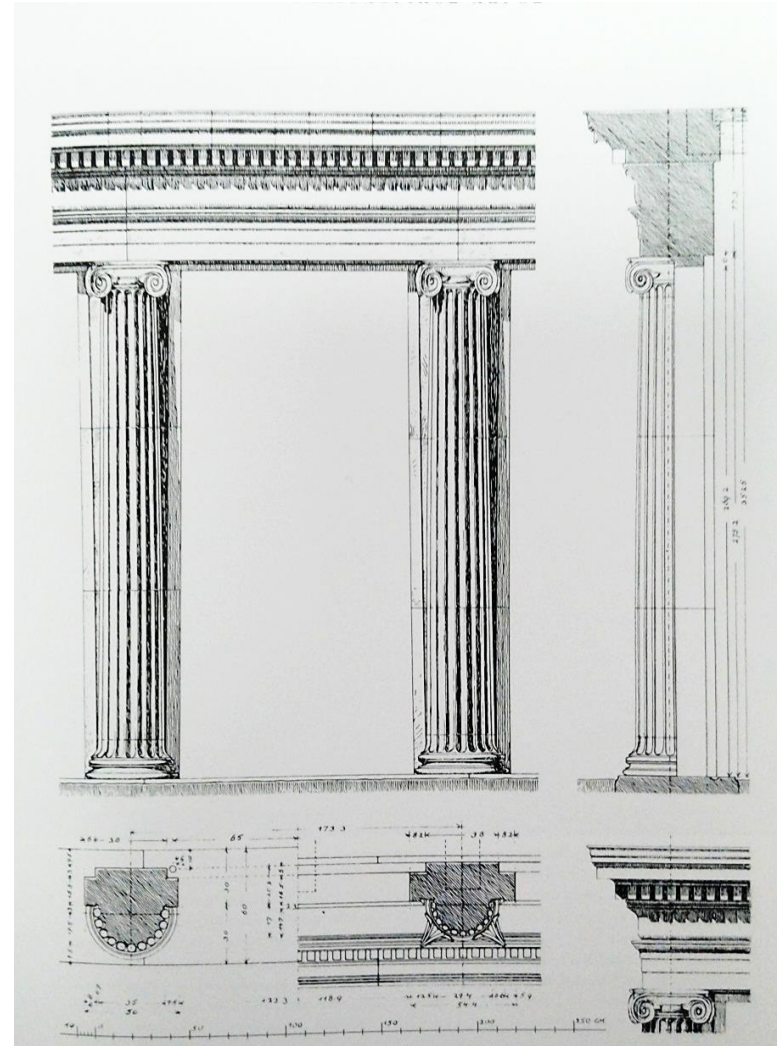
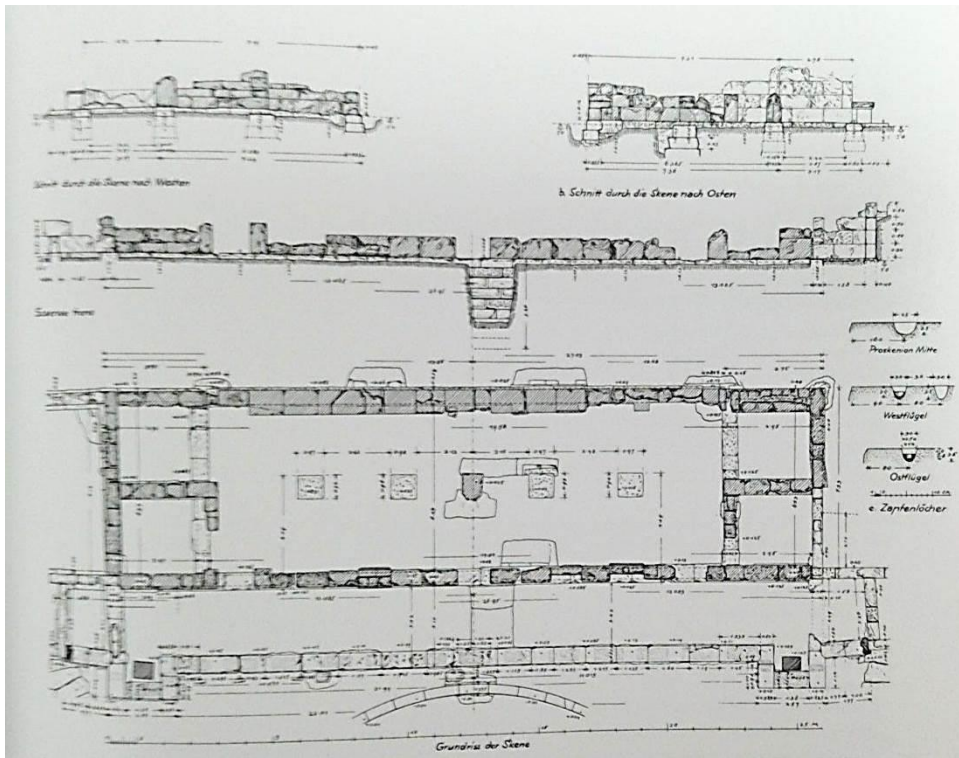



# Τύπος Ε

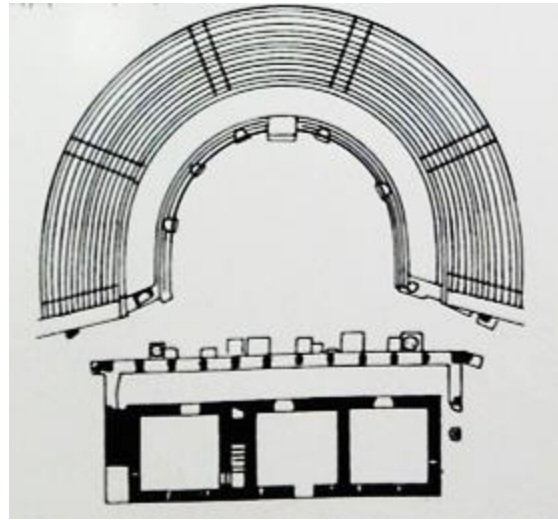
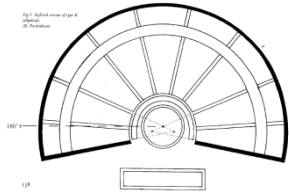

PRIENE



# Τύπος Ε

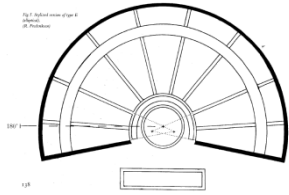

## EPHESOS

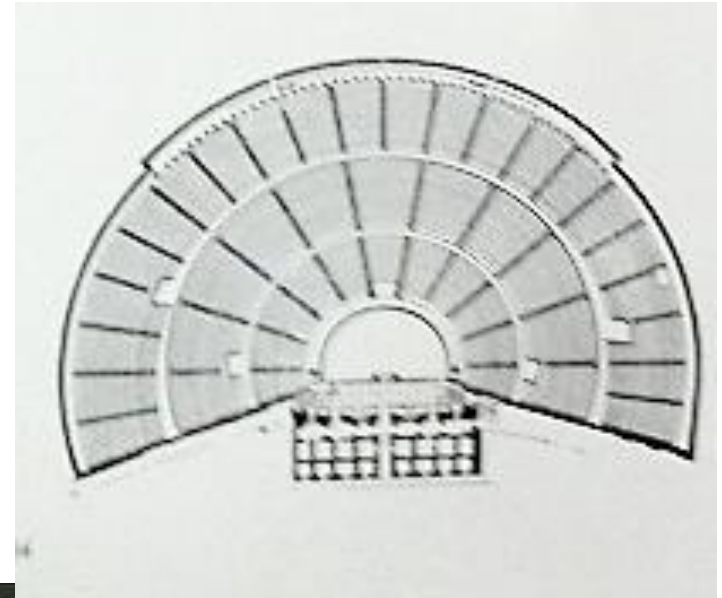

# Τύπος Ε

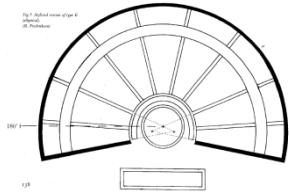

## LINDOS

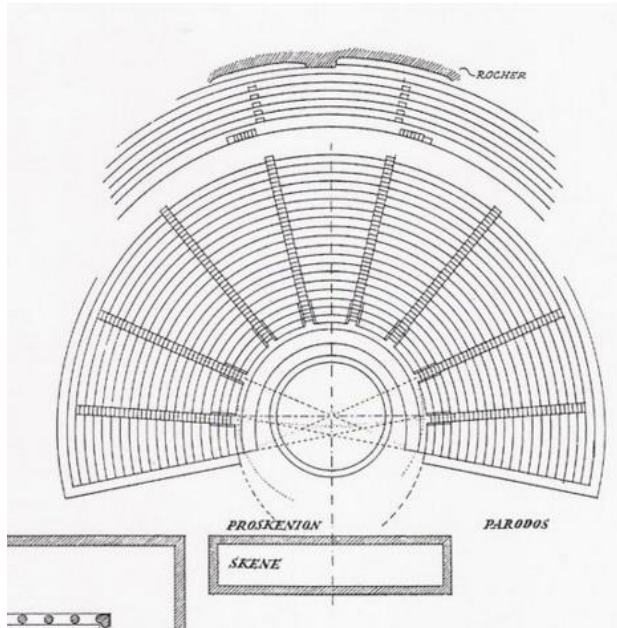

# Τύπος F

*Fig.6. Stylized version of type F (pointed). Based on Kassope. (R. Frederiksen)*

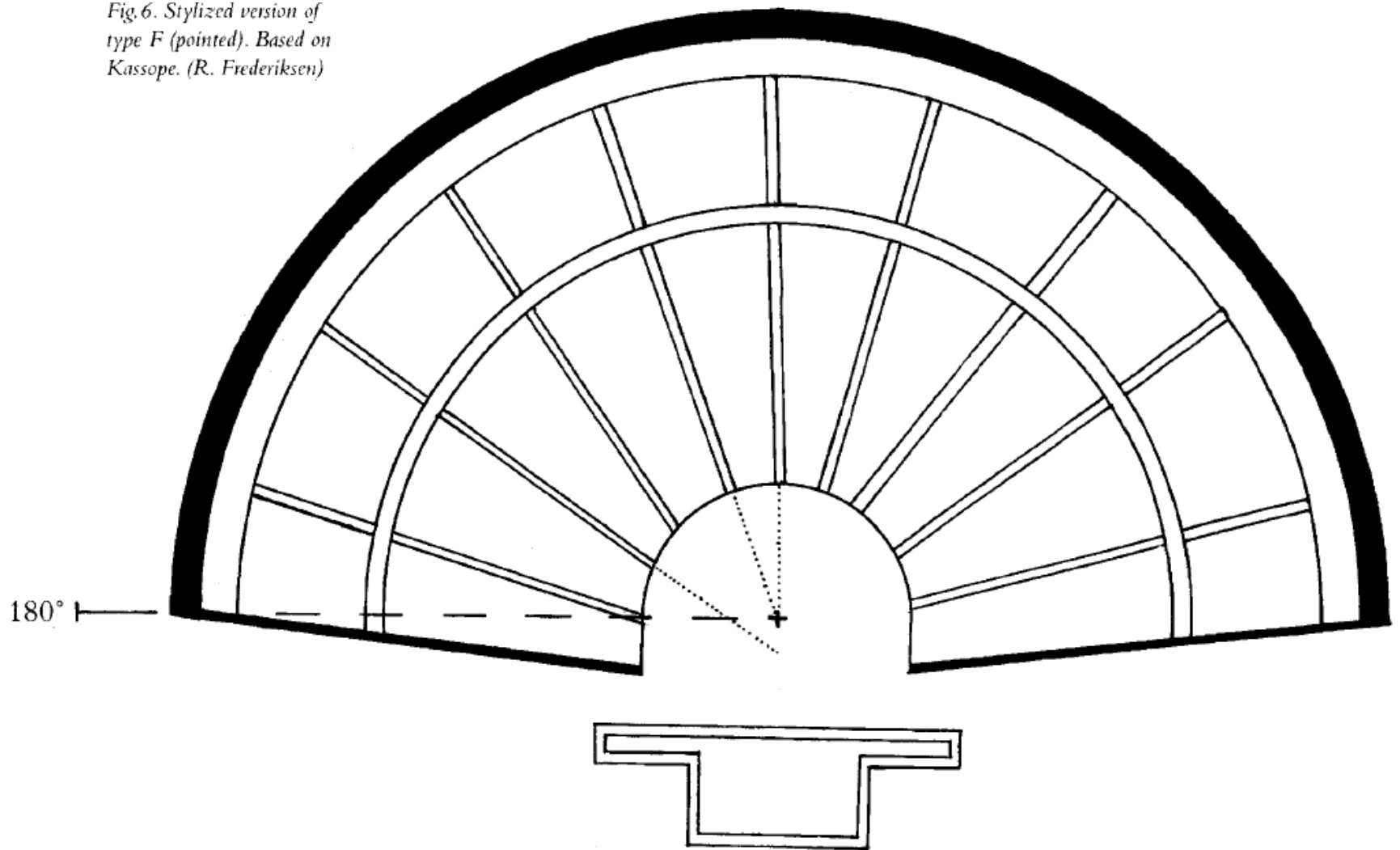

# Τύπος F

Fig. 6. Stylized version of type F (pointed). Based on Kassope (R. Friederksen)

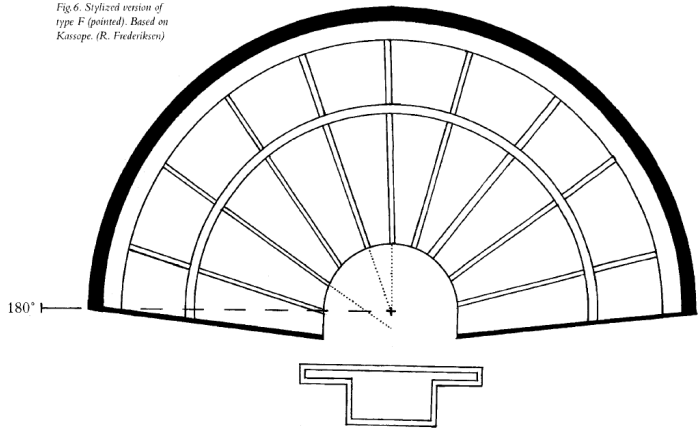

## THASOS

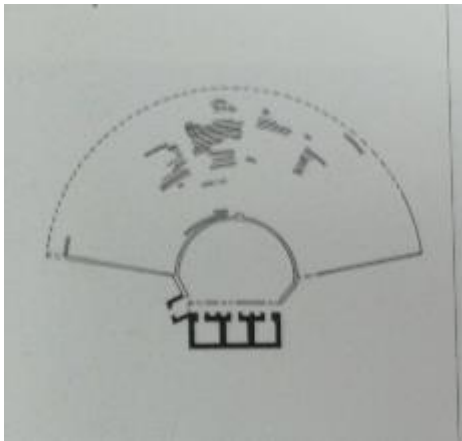

# Τύπος F

*Fig. 6. Stylized version of type F (pointed). Based on Kassope (R. Frederiksen)*

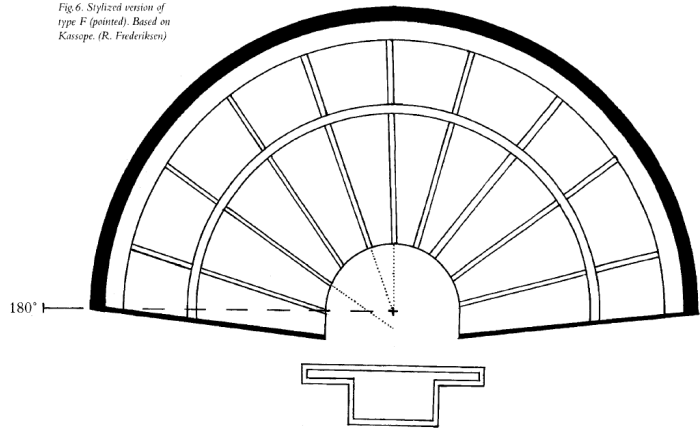

## CASSOPE EPIRUS



# Τύπος G

Fig 7. Stylized version of type  
G (Pergeion-type).  
(R. Fredericksen)

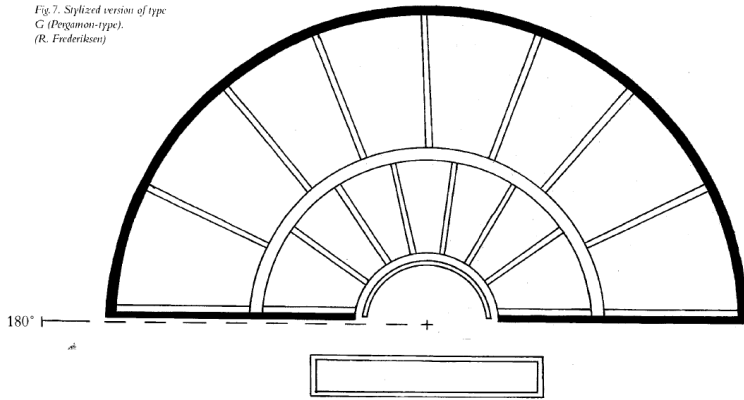

## Θέατρο Περγάμου

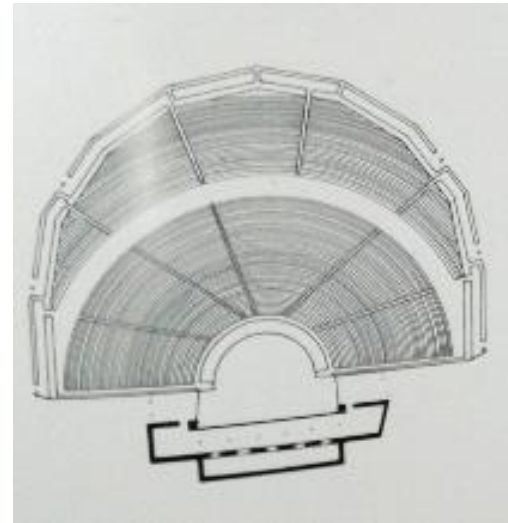

## Θέατρο Μεταποντίου

# BIBLIOGRAPHY

- Anti, C, 1947 *Teatri greci arcaici*
- Γεωργουσόπουλος, Κ. – Σ. Γώγος. 2003. *Επίδαυρος. Το Αρχαίο Θέατρο, οι Παραστάσεις*
- Γώγος, Σ. 2005. *Το αρχαίο θέατρο του Διονύσου*
- Dilke, O.A.W. 1948. «The Greek Theatre Cavea», *BSA* 43:125 κε
- Frederiksen, R. 2000. «The Greek Theatre. A Typical Building in the Urban Centre of the Polis?», στο T.H. Nielsen, *Even more Studies in the Ancient Greek Polis. Papers from the Copenhagen Polis Centre 6 (Historia Einzelschriften 162)* 65-124
- Gebhard, E. 1974. «The Form of the Orchestra in the Early Greek Theatre», *Hesperia* 43: 428 κε.
- Kanta, A. 2013. *Minoan Crete and the Origins of Ancient Greek Theatre. A Perspective from the Theatre of Gortys*, Heraklion
- Moretti, J.C. 2011. *Θέατρο και κοινωνία στην Αρχαία Ελλάδα*. Αθήνα: Πατάκης
- Μποσνάκης, Δ., Δ. Γκαγκτζής 1996. *Αρχαία θέατρα*



# RUNE FREDERICKSEN 2002

- 1. URBAN THEATER
- 2. THEATER OUTSIDE THE CITY WALLS AND INSIDE A SANCTUARY
- 3. OUTSIDE CITY WALLS AND OUTSIDE A SANCTUARY

# INDEPEDENCE MEGALOPOLIS

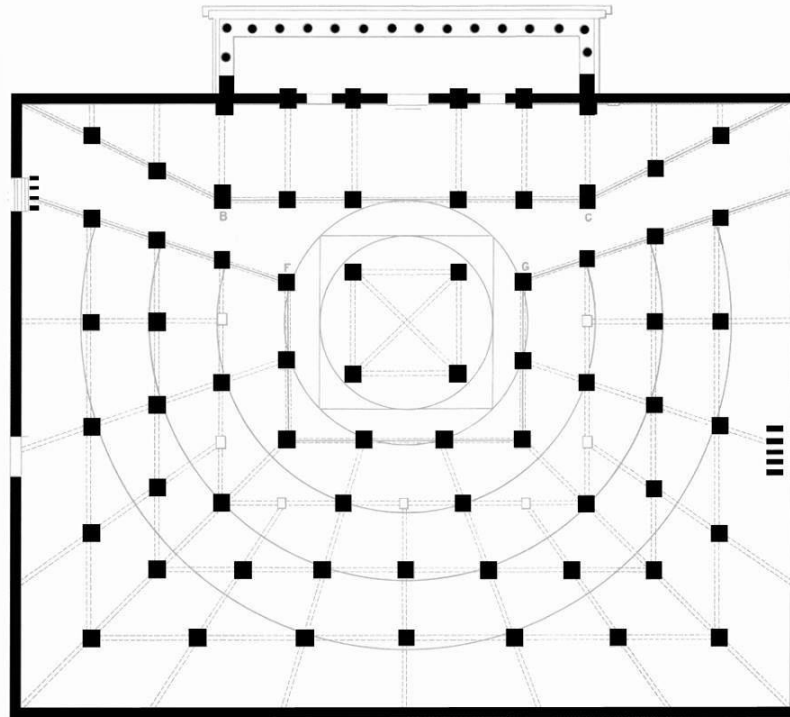

**THERSILION**

Assembly hall (bouleuterion) for 10.000 people /// Megalopolis, Arcadia, Greece /// 371 BC



# CEREMONIAL THEATERS CABEIROI

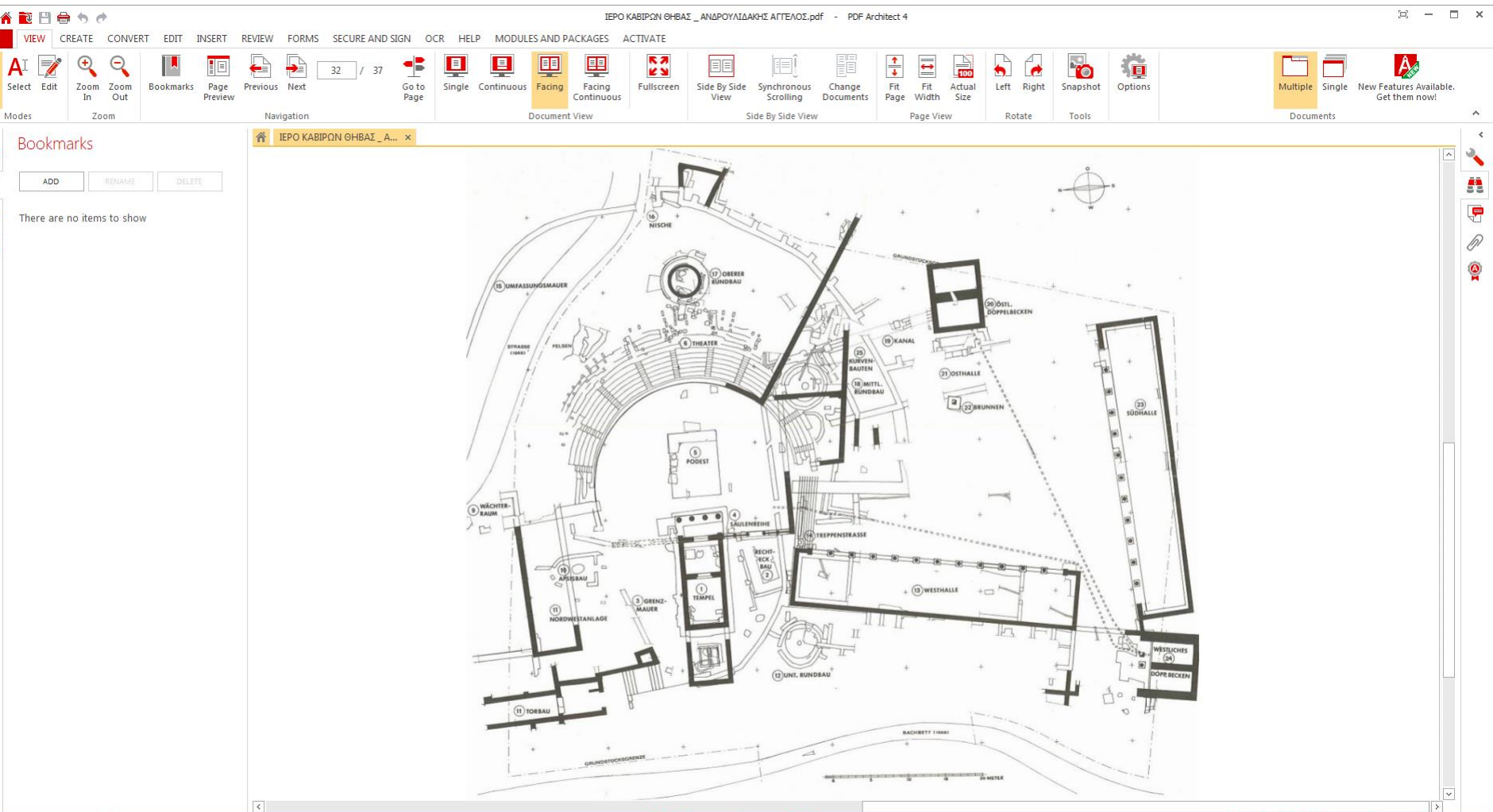

# SANCTUARY OF ARTEMIS, SPARTA, 570 π.Χ.

*Διαμαστίγωσις*

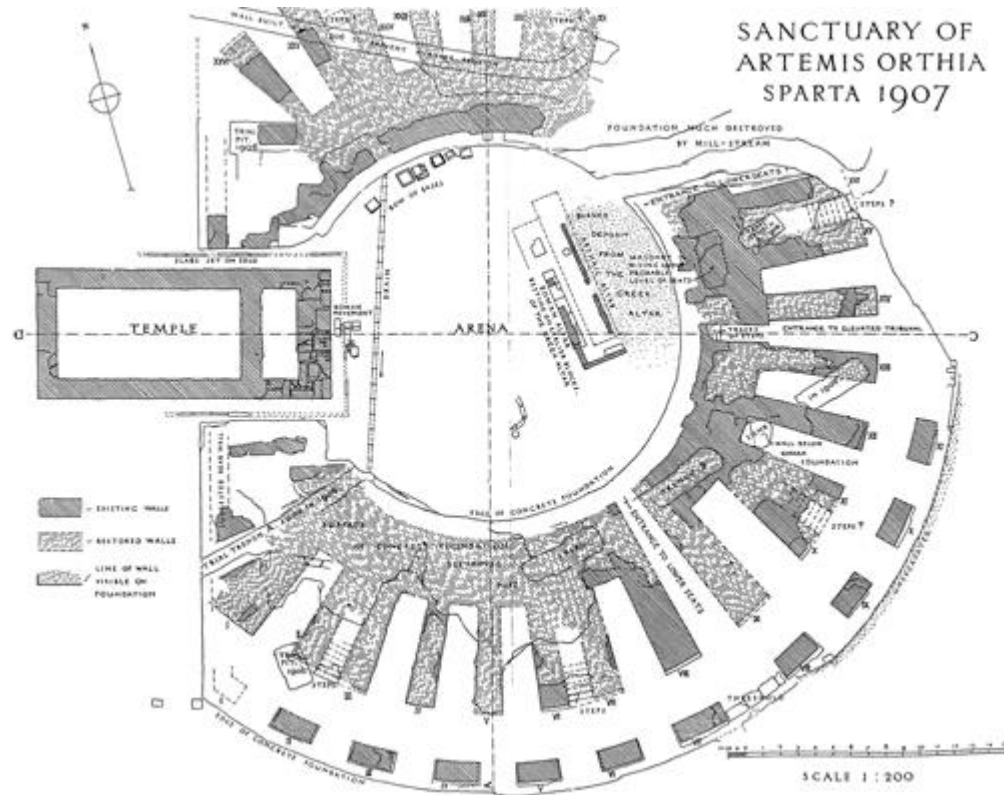

# PRIENE

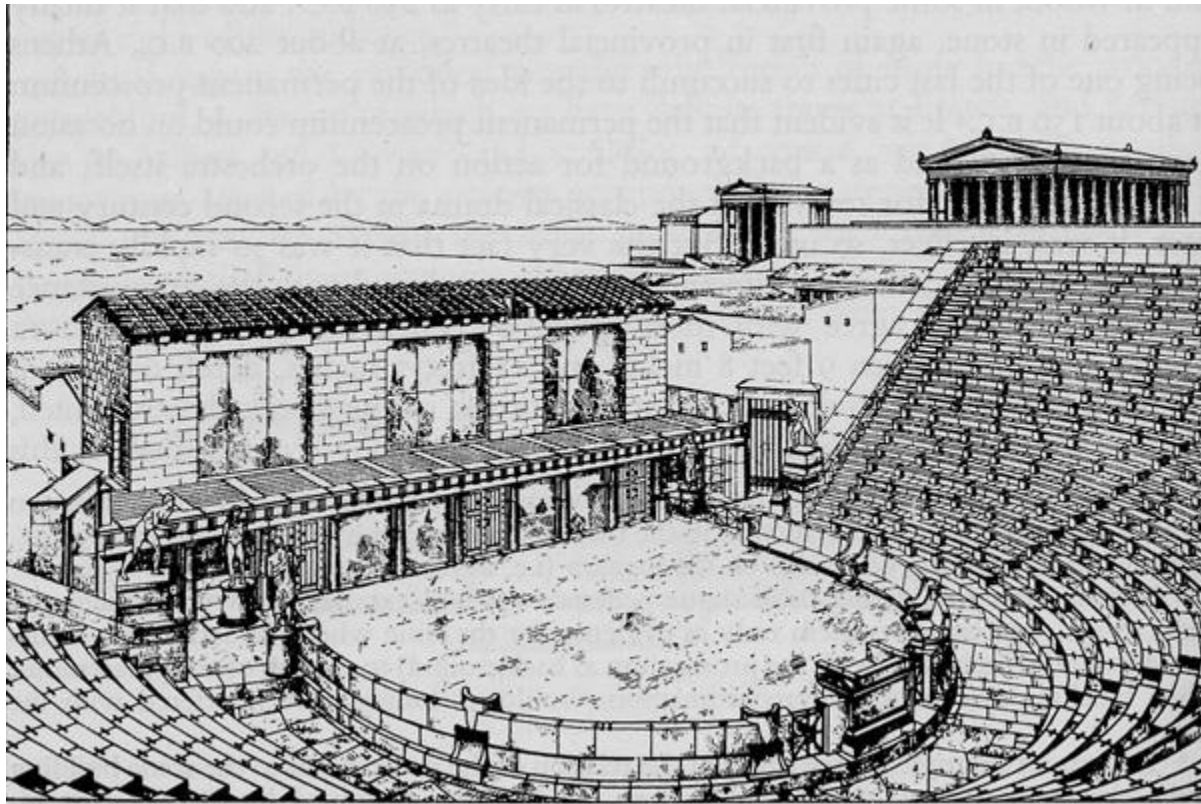

# OROPOS

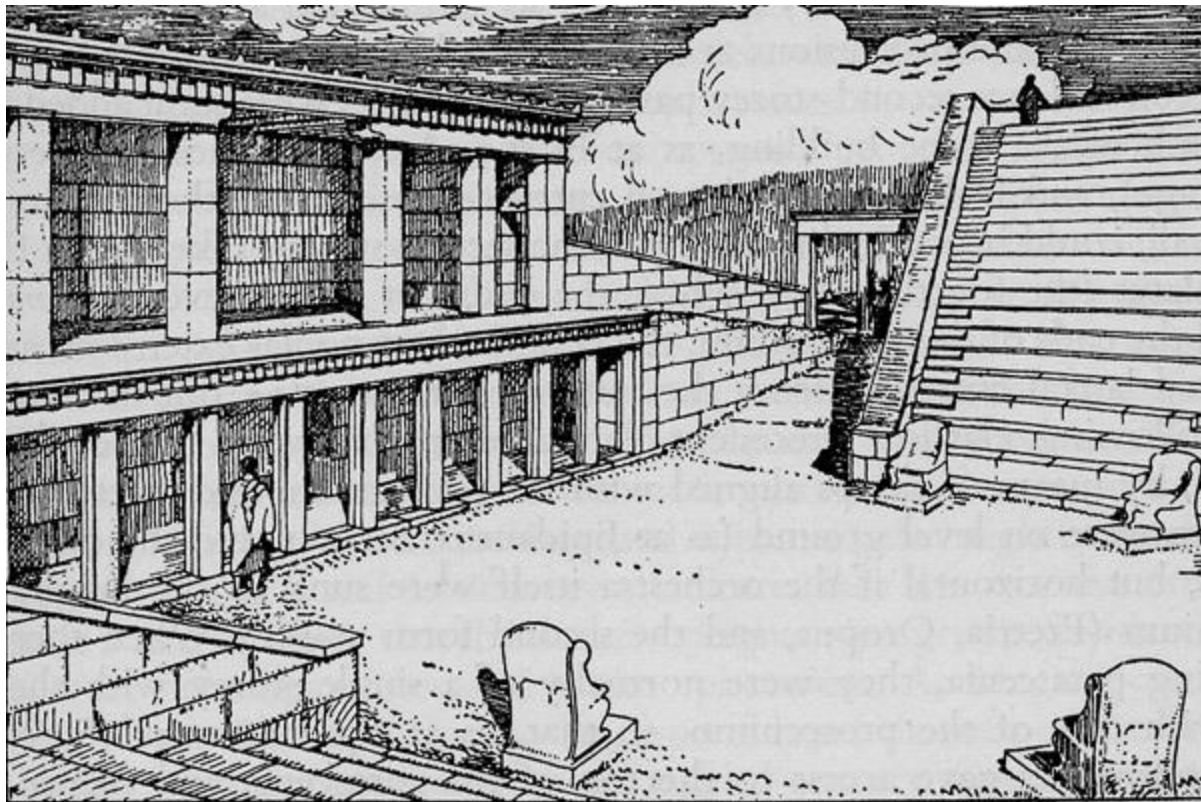

# VESSEL FROM ITALY WITH AEYRIPIDES' PLAY IN A THEATER



# LINDOS, RODOS / RHODES. 250 BC.

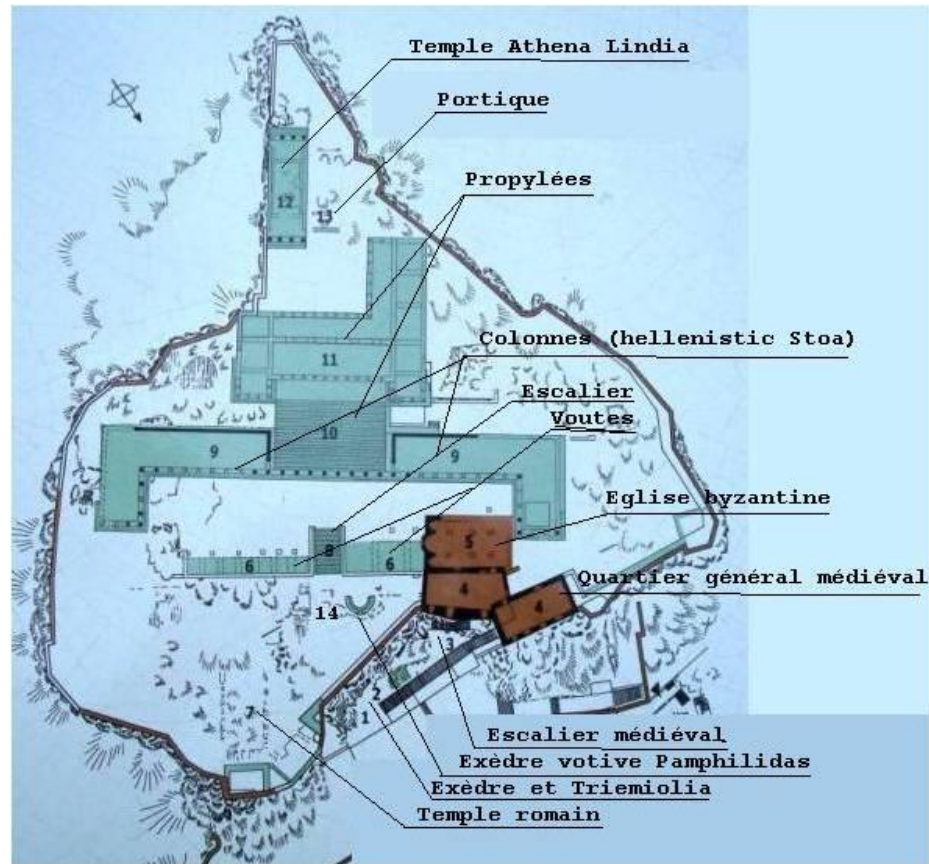



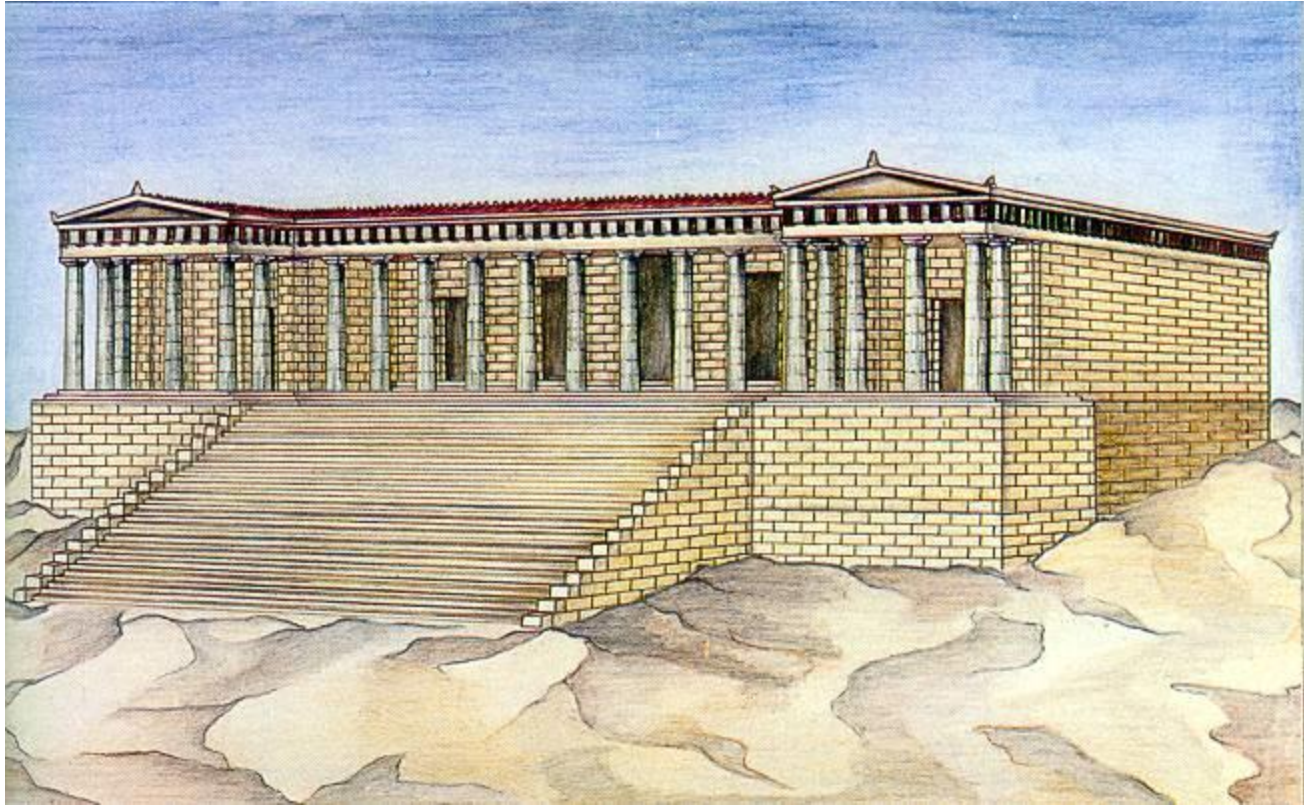

# TOMB FACADES AS THEATER SCENES

THE EARLIEST ALEXANDRIAN MONUMENTAL TOMBS AND THEIR ANTECEDENTS

29

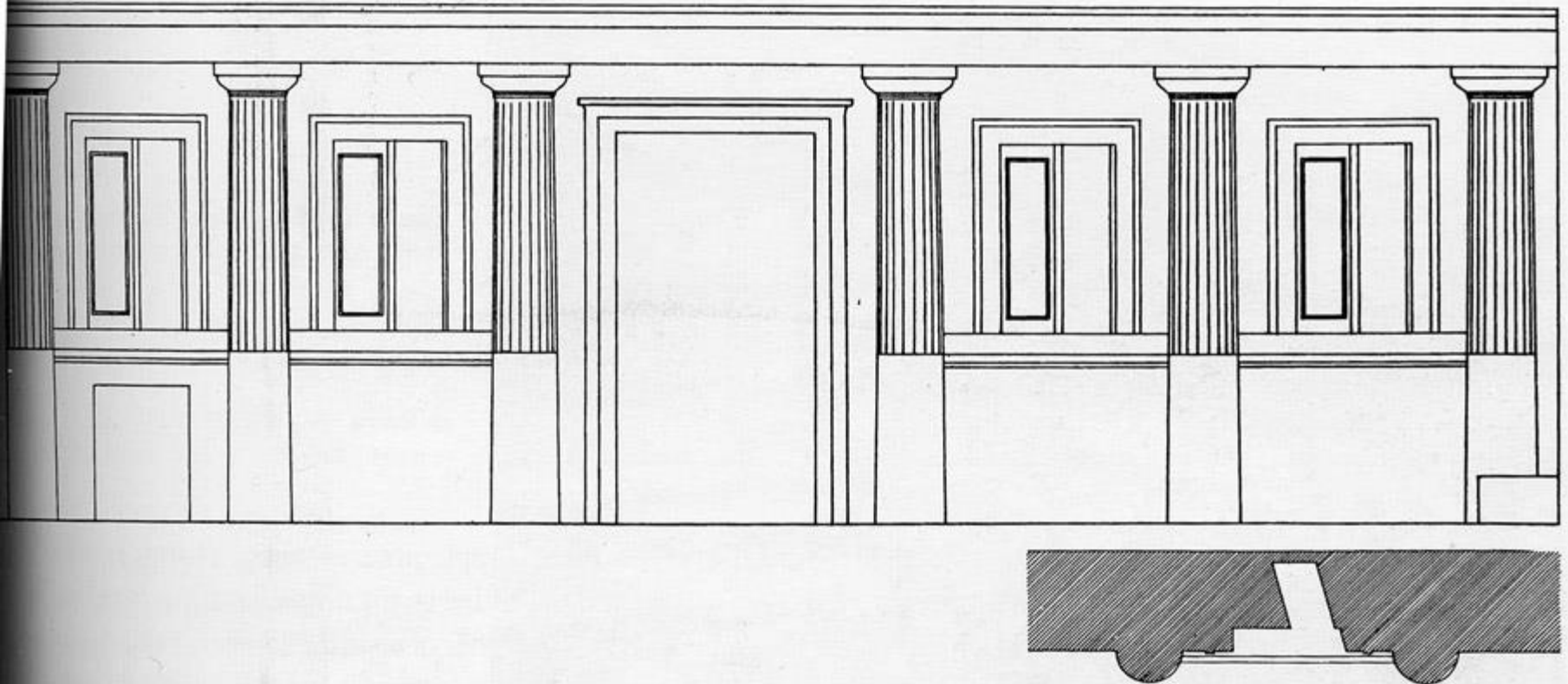

Figure 12. Hypogeum A: reconstruction of the south wall of the anteroom (after Adriani 1966, pl. 45, fig. 171).