



ΕΛΛΗΝΙΚΗ ΔΗΜΟΚΡΑΤΙΑ

Εθνικόν και Καποδιστριακόν
Πανεπιστήμιον Αθηνών

— ΙΔΡΥΘΕΝ ΤΟ 1837 —

Συγκρότημα Ευρίπου
Γενικό Τμήμα

Πρόγραμμα Μεταπτυχιακών Σπουδών
Σχεδίαση και Κατασκευή Συστημάτων Αγωνιστικών Οχημάτων

ΜΣΚ 21 – CAD/CAM/CNC

ΣΗΜΕΙΩΣΕΙΣ ΜΑΘΗΜΑΤΟΣ

ΜΕΡΟΣ 3. ΣΥΣΤΗΜΑΤΑ ΚΑΤΕΡΓΑΣΙΩΝ

Αγαθοκλής Αν. Κριμπένης, Δρ. Μηχανολόγος Μηχανικός
Επίκουρος Καθηγητής

2020

Περιεχόμενα

Ενότητα Δ: Συστήματα Κατεργασιών

- Group Technology
- Cellular Manufacturing

Group Technology

Introduction to Group Technology (GT)

- ① **Group Technology (GT)** is a manufacturing philosophy in which similar parts are identified and grouped together to make advantage of their similarities in design and production.
- ② Similar parts arranged into part families, where each part family possesses similar design and/or manufacturing characteristics.
- ③ Grouping the production equipment into machine cells, where each cell specializes in the production of a part family, is called **cellular manufacturing**.

Implementing Group Technology (GT)

- There are two major tasks that a company must undertake when it implements Group Technology.

1. Identifying the part families.

If the plant makes 10,000 different parts, reviewing all of the part drawings and grouping the parts into families is a substantial task that consumes a significant amount of time.

2. Rearranging production machines into cells.

It is time consuming and costly to plan and accomplish this rearrangement, and the machines are not producing during the changeover.

Benefits of Group Technology (GT)

- ⦿ GT promotes *standardization* of tooling, fixturing, and setups.
- ⦿ *Material handling is reduced* because parts are moved within a machine cell rather than within the entire factory.
- ⦿ *Process planning and production scheduling* are simplified.
- ⦿ *Setup times are reduced*, resulting in lower manufacturing lead times

Part Families (1)

- **A part family** is a collection of parts that are similar either because of geometric shape and size or because similar processing steps are required in their manufacture.
- The parts within a family are different, but their similarities are close enough to merit their inclusion as members of the part family.

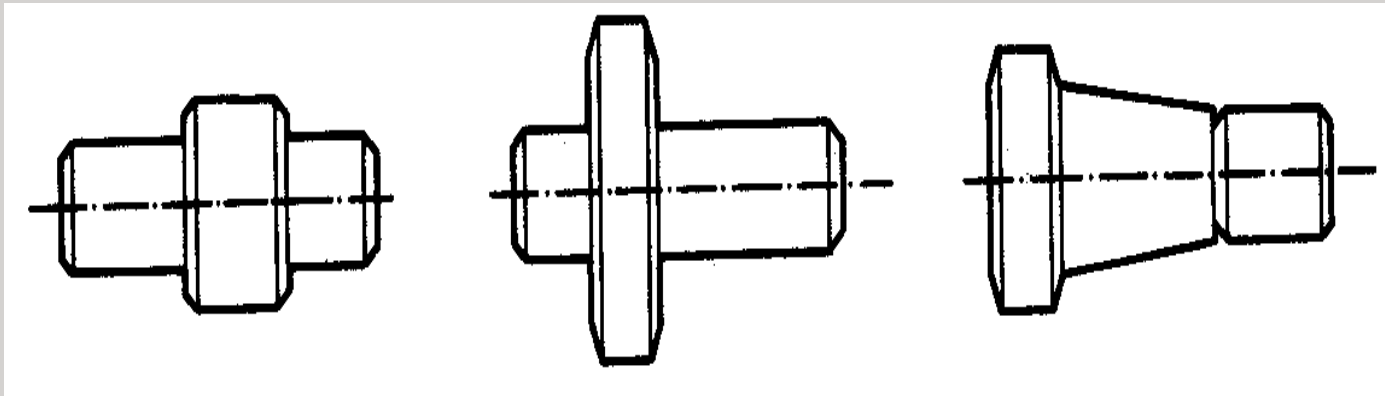

Rotational part family requiring similar turning operations

Part Families (2)

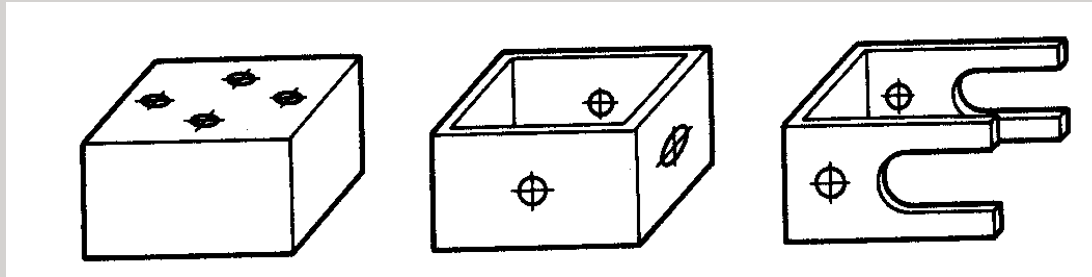

Similar prismatic parts requiring similar milling operations

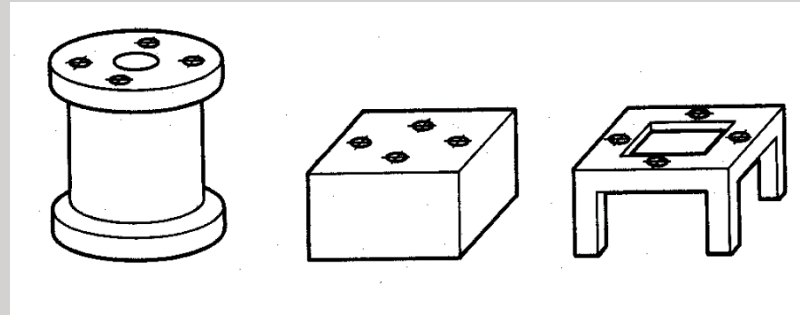

Dissimilar parts requiring similar machining operations (hole drilling, surface milling, etc)

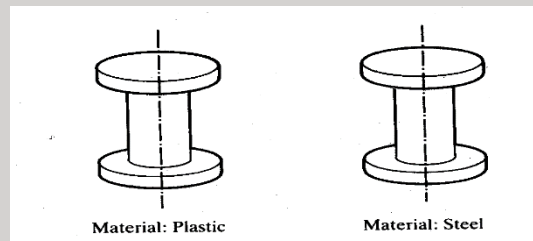

Identical designed parts requiring completely different manufacturing processes

Part Family Machining (1)

- One of the important manufacturing advantages of grouping workparts into families can be explained with reference to figures below.

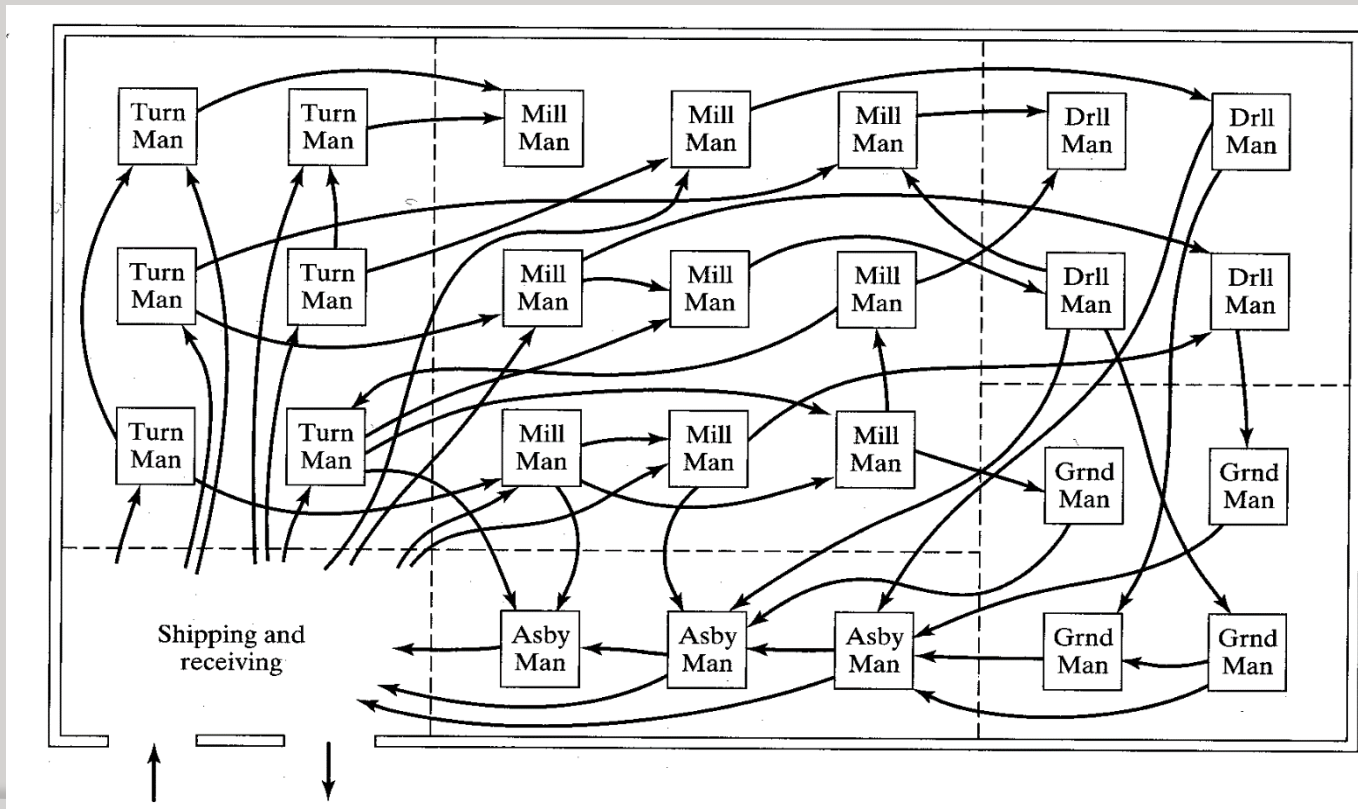

Part Family Machining (2)

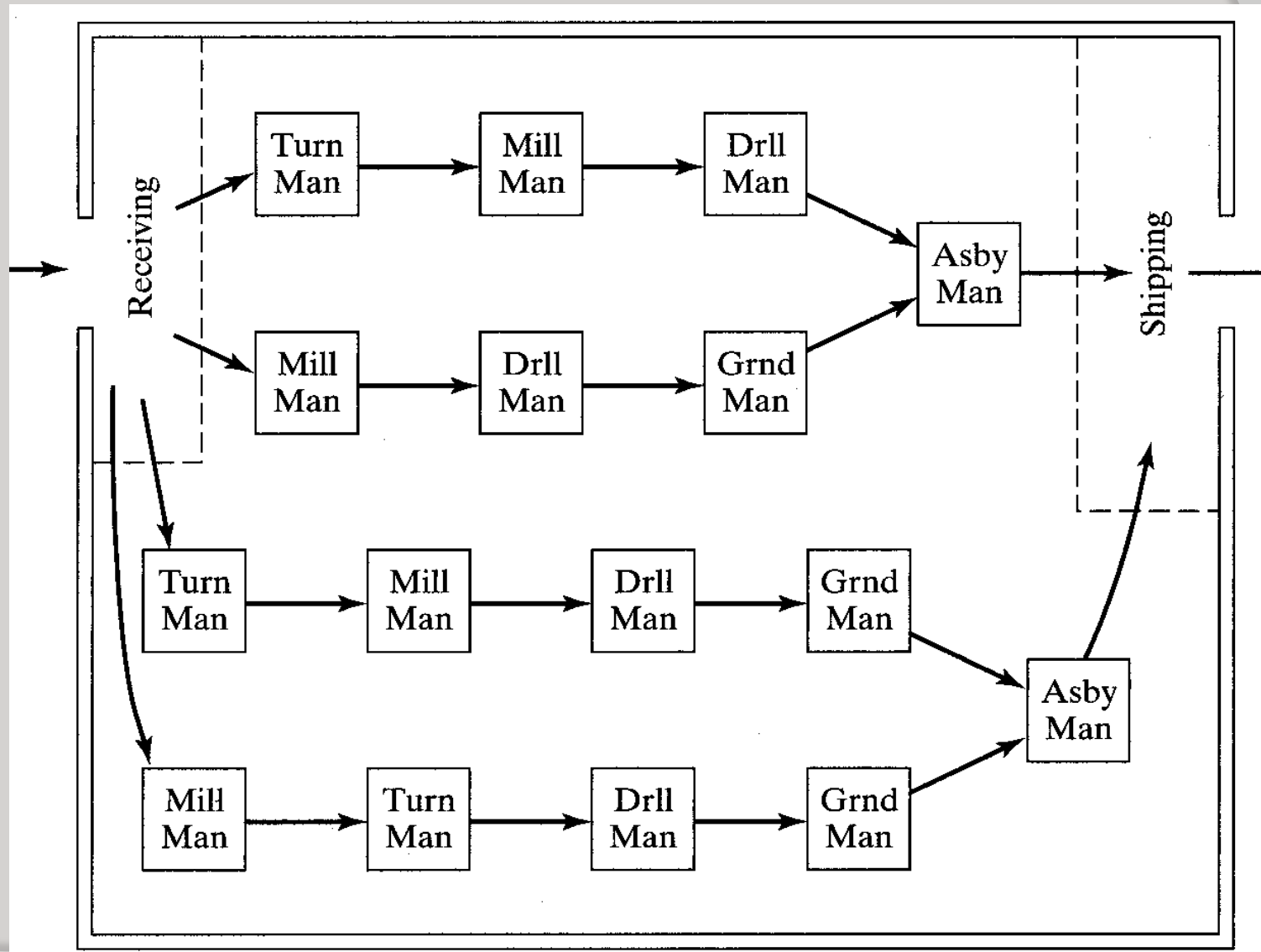

Grouping Part Families

- ⦿ There are ***three general methods*** for solving part families grouping. All the three are time consuming and involve the analysis of much of data by properly trained personnel.
- ⦿ The three methods are:
 1. *Visual inspection.*
 2. *Parts classification and coding.*
 3. *Production flow analysis.*

1. Visual Inspection Method

- The visual inspection method is the ***least sophisticated*** and ***least expensive method***.

It involves the **classification** of parts into families by looking at ***either the physical parts or their photographs*** and arranging them into groups having similar features.

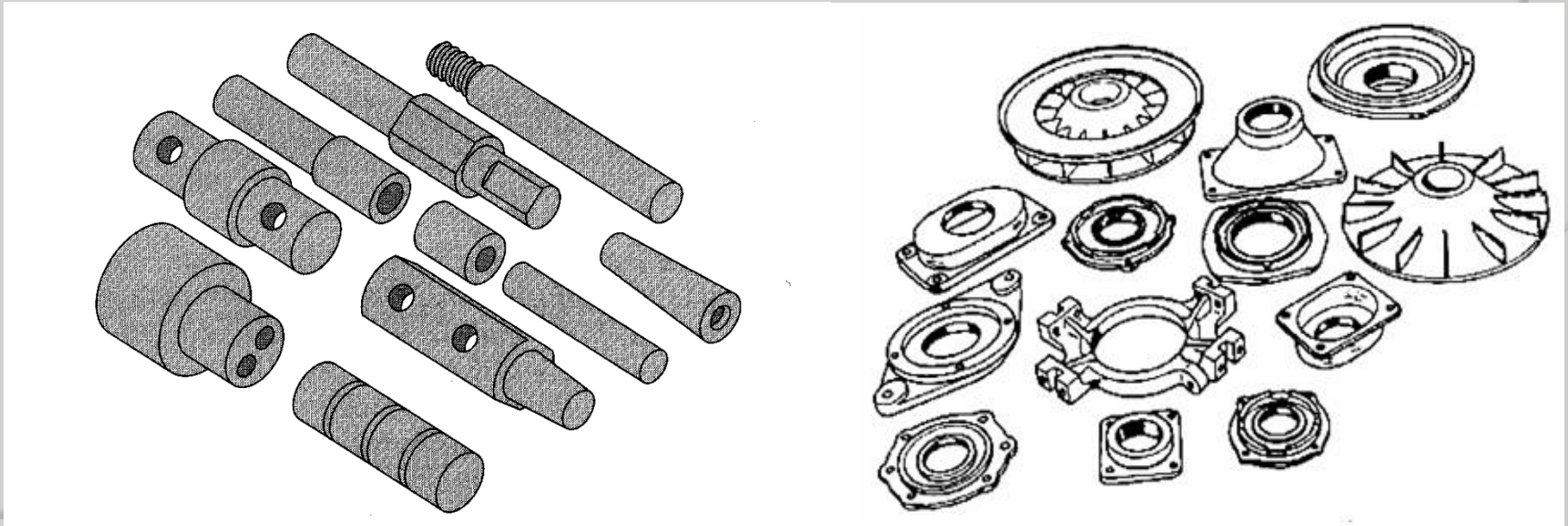

2. Parts Classification and Coding (1)

- ⦿ In parts classification and coding, similarities among parts are identified, and these similarities are related in a coding system.
- ⦿ Two categories of part similarities can be distinguished:
 1. ***Design attributes***, which concerned with part characteristics such as geometry, size and material.
 2. ***Manufacturing attributes***, which consider the sequence of processing steps required to make a part.

2. Parts Classification and Coding (2)

- Reasons for using a classification and coding system:

- 1. Design retrieval.**

A designer faced with the task of developing a new part can use a design retrieval system to determine if a similar part already exist. A simple change in an existing part would take much less time than designing a whole new part from scratch.

- 2. Automated process planning.**

The part code for a new part can be used to search for process plans for existing parts with identical or similar codes.

- 3. Machine cell design.**

The part codes can be used to design machine cells capable of producing all members of a particular part family, using the composite part concept.

2. Parts Classification and Coding (3)

- **A part coding system consists of a sequence of symbols** that identify the part's design and/or manufacturing attributes.
- The symbols are usually **alphanumeric**, although most systems use only numbers.
- **The three basic coding structures are:**
 1. **Chain-type structure**, also known as a **polycode**, in which the interpretation of each symbol in the sequence is always the same, it does not depend on the value of the preceding symbols.

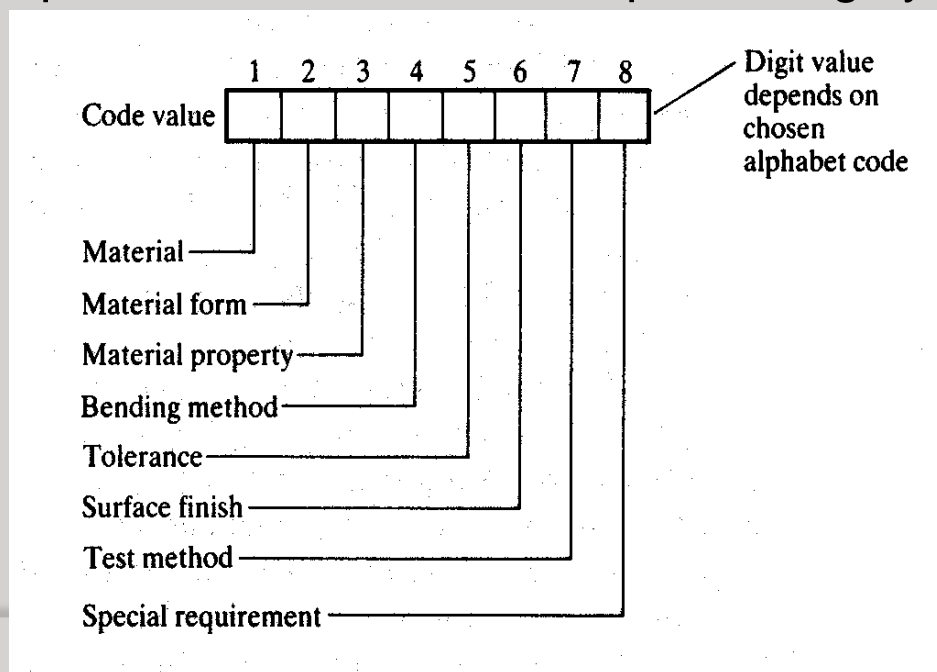

2. Parts Classification and Coding (4)

2. **Hierarchical structure**, also known as a **monocode**, in which the interpretation of each successive symbol depends on the value of the preceding symbols.

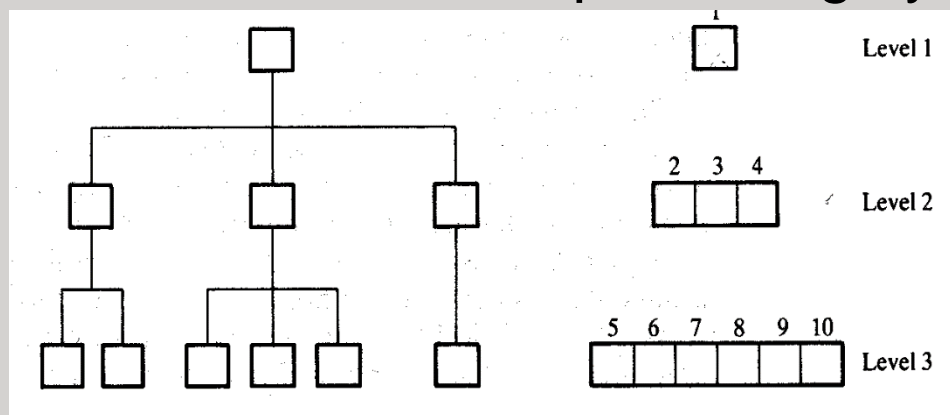

3. **Hybrid structure**, a combination of hierarchical and chain-type structures.

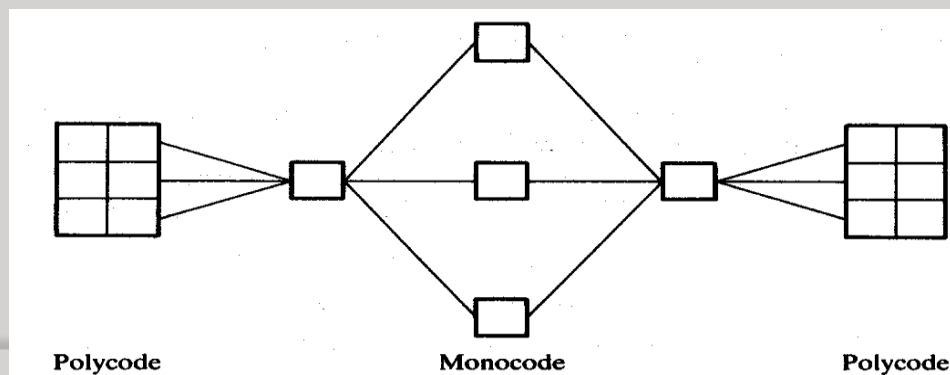

Opitz Classification and Coding System (1)

- It is intended for machined parts and uses the following digits sequence
 - Form Code** **1 2 3 4 5** *for design attributes*
 - Supplementary Code** **6 7 8 9** *for manufacturing attributes*
 - Secondary Code** **A B C D** *for production operation type & sequence*

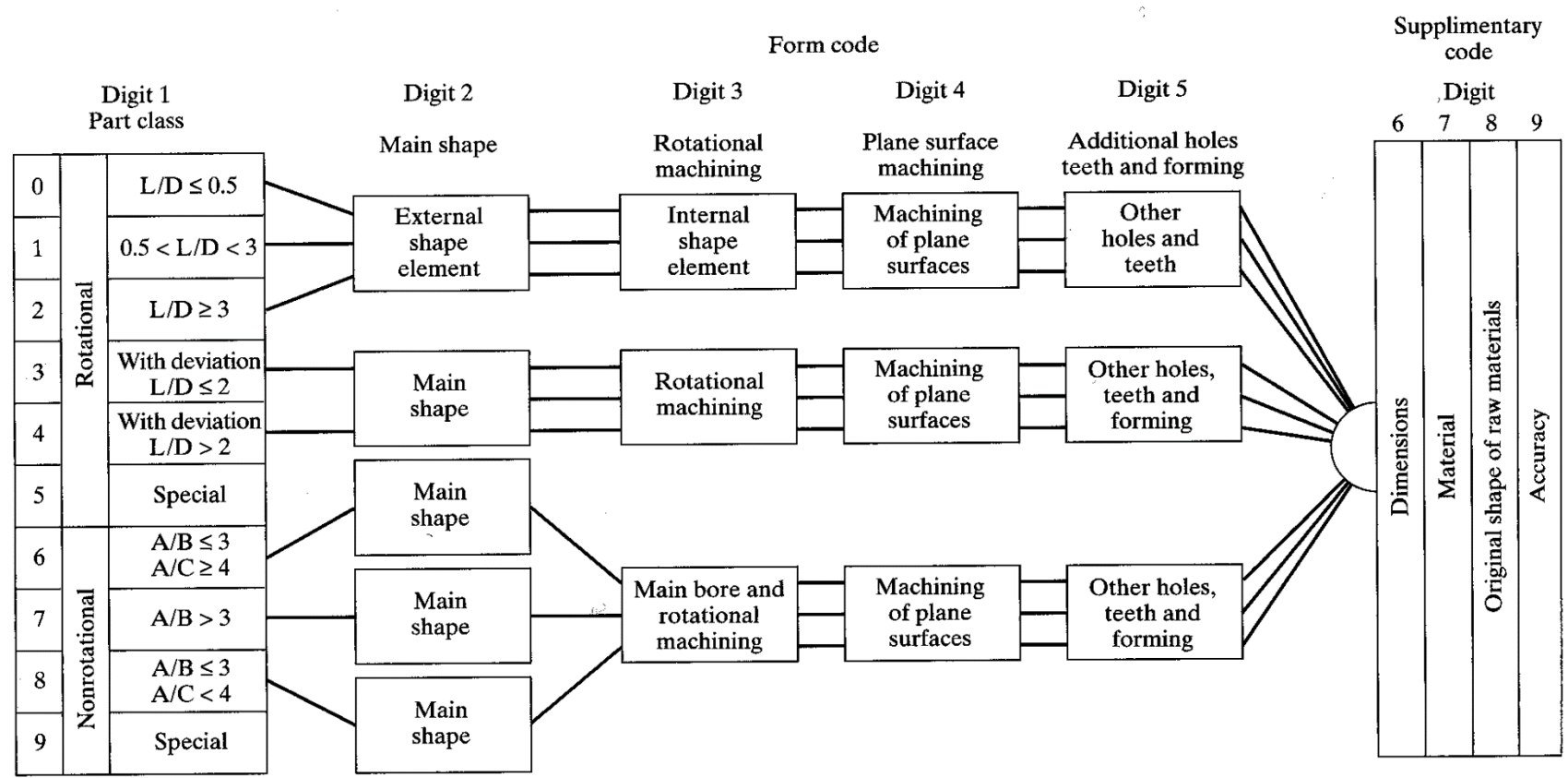

Opitz Classification and Coding System (2)

○ Digits (1-5) for Rotational parts in the Opitz System

Digit 1		Digit 2		Digit 3		Digit 4		Digit 5			
Part class		External shape, external shape elements		Internal shape, internal shape elements		Plane surface machining		Auxiliary holes and gear teeth			
0 1 2 3 4 5 6 7 8 9	Rotational parts	0	$L/D \leq 0.5$	0	Smooth, no shape elements	0	No hole, no breakthrough	0	No surface machining	0	No auxiliary hole
		1	$0.5 < L/D < 3$	1	No shape elements	1	No shape elements	1	Surface plane and/or curved in one direction, external	1	Axial, not on pitch circle diameter
		2	$L/D \geq 3$								
		3		3	Functional groove	3	Functional groove	3	External groove and/or slot	3	Radial, not on pitch circle diameter
		4									
5		5	Thread	5	Thread	5	External plane surface and/or slot, external spline	5	Axial and/or radial on PCD and/or other directions		
6										6	Functional groove
7		7	Functional cone	7	Functional cone	7	Internal spline (polygon)	7	Bevel gear teeth		
8		8	Operating thread	8	Operating thread	8	Internal and external polygon, groove and/or slot	8	Other gear teeth		
9		9	All others	9	All others	9	All others	9	All others		

Opitz Classification and Coding System (3)

◎ Example.

- Given the rotational part design below, determine the form code in the Opitz parts classification and coding system.

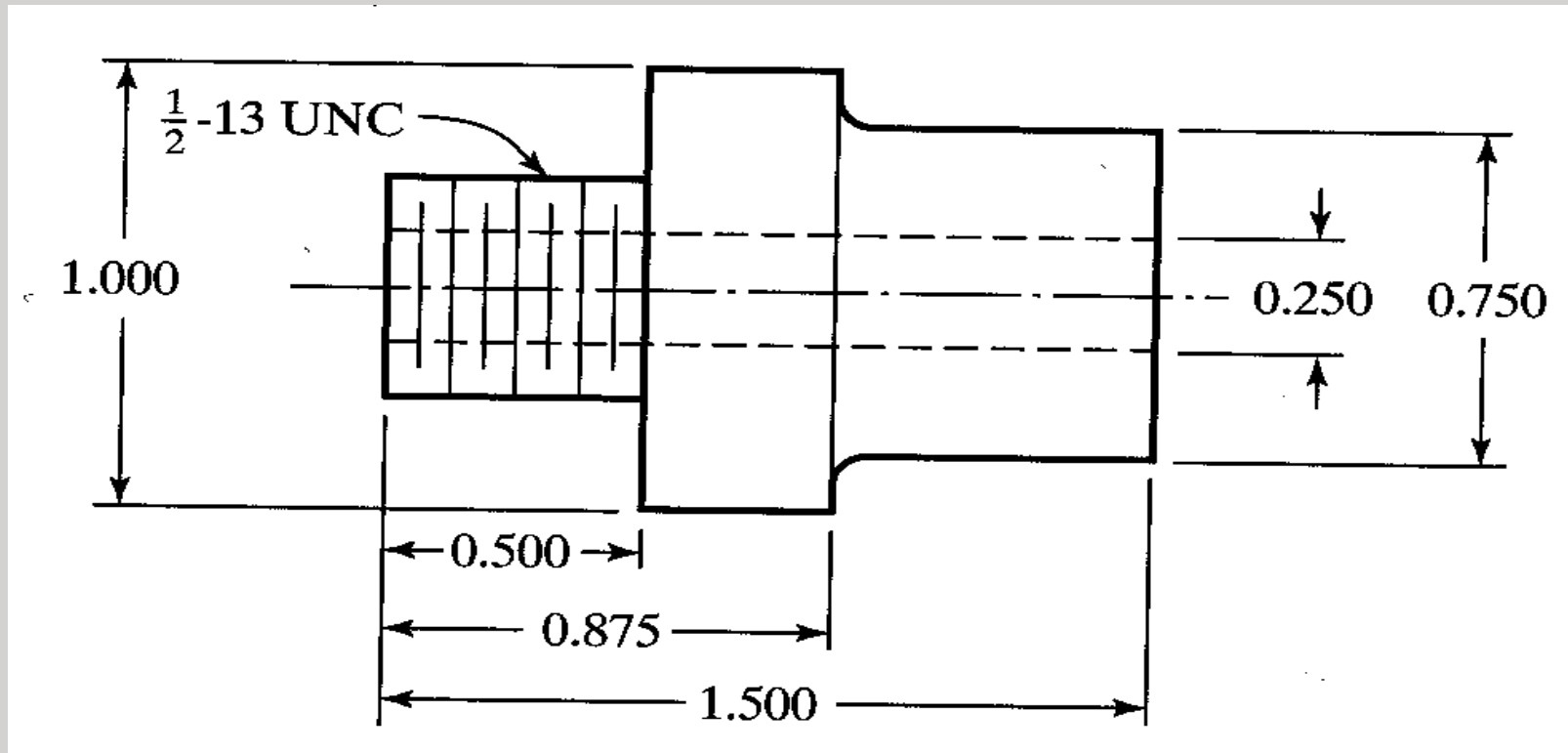

Opitz Classification and Coding System (4)

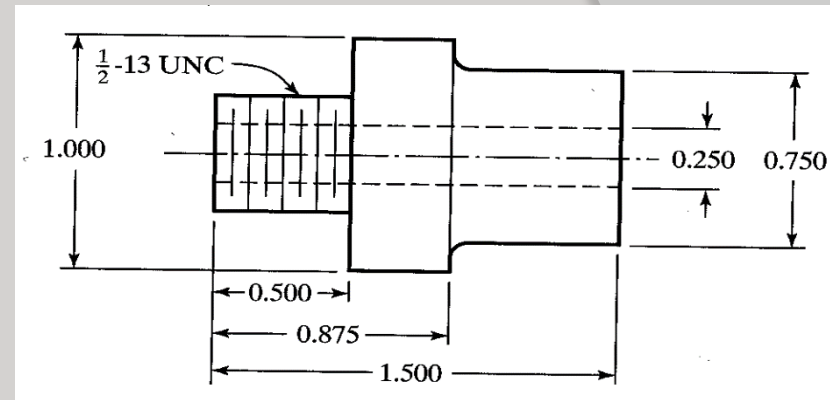

◎ Solution

- *Length-to-diameter ratio:* **L/D = 1.5** **Digit 1 = 1**
- *External shape:* **both ends stepped with screw thread on one end** **Digit 2 = 5**
- *Internal shape:* **part contains a through hole** **Digit 3 = 1**
- *Plane surface machining:* **none** **Digit 4 = 0**
- *Auxiliary holes, gear teeth, etc.:* **none** **Digit 5 = 0**

◎ The form code in the Opitz system is **15100**

3. Production Flow Analysis – PFA (1)

- ⦿ **Production flow analysis (PFA)** is a method for identifying part families and associated machine groupings that uses the information contained on process plans rather than on part drawings.
- ⦿ Workparts with identical or similar process plans are classified into part families. These families can then be used to form logical machine cells in a group technology layout.
- ⦿ The procedure in production flow analysis must begin by defining the scope of the study, which means deciding on the population of parts to be analyzed.

3. Production Flow Analysis – PFA (2)

- ◎ The procedure of Production flow analysis (PFA) consists of the following steps:
 1. **Data Collection.** The minimum data needed in the analysis are the part number and operation sequence, which is obtained from process plans.
 2. **Sortation of process plans.** A sortation procedure is used to group parts with identical process plans.
 3. **PFA Chart.** The processes used for each group are then displayed in a PFA chart as shown below.

Machines	Parts								
	A	B	C	D	E	F	G	H	I
1	1			1				1	
2					1				1
3			1		1				1
4		1				1			
5	1							1	
6			1						1
7		1				1	1		

3. Production Flow Analysis – PFA (3)

- ⦿ The procedure of Production flow analysis (PFA) consists of the following steps (contd):

4. **Clustering Analysis.** From the pattern of data in the PFA chart, related groupings are identified and rearranged into a new pattern that brings together groups with similar machine sequences.

Machines	Parts								
	C	E	I	A	D	H	F	G	B
3	1	1	1						
2		1	1						
6	1		1						
1				1	1	1			
5				1		1			
7							1	1	1
4							1		1

Cellular Manufacturing

Introduction to Cellular Manufacturing

- ◎ **Cellular Manufacturing** is an application of group technology in which dissimilar machines or processes have be aggregated into cells,
 - each of which is dedicated to the production of a part or product family or a limited group of families.
- ◎ **Benefits of Cellular Manufacturing**

<i>Rank</i>	<i>Reason for Installing Manufacturing Cells</i>	<i>Average Improvement (%)</i>
1	Reduce throughput time (Manufacturing lead time)	61
2	Reduce work-in-process	48
3	Improve part and/or product quality	28
4	Reduce response time for customer orders	50
5	Reduce move distances	61
6	Increase manufacturing flexibility	
7	Reduce unit costs	16
8	Simplify production planning and control	
9	Facilitate employee involvement	
10	Reduce setup times	44
11	Reduce finished goods inventory	39

Composite Part Concept (1)

- ◎ **A Composite Part** for a given family, which includes all of the design and manufacturing attributes of the family.
- ◎ In general, an individual part in the family will have some of the features that characterize the family but not all of them. The composite part possesses all of the features

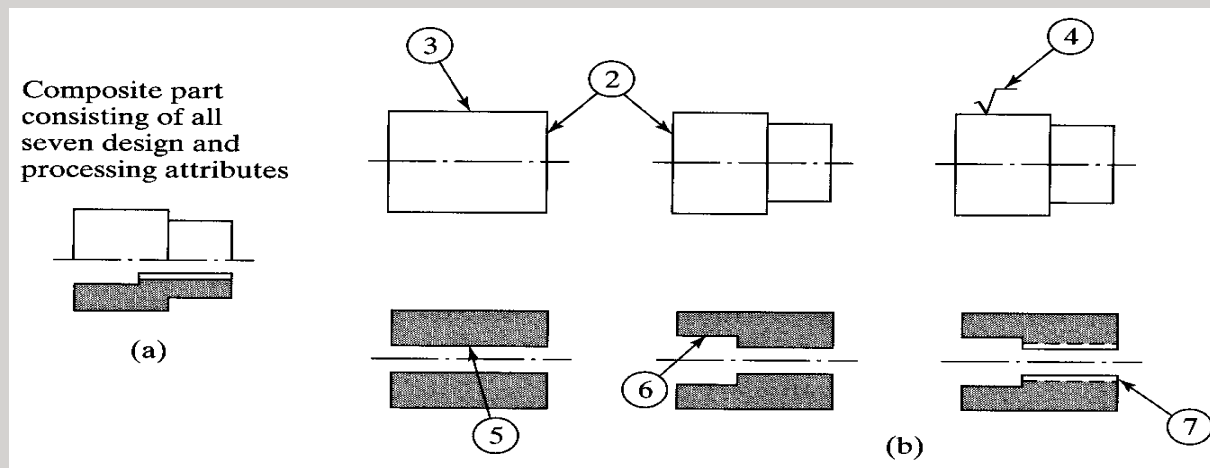

Composite Part Concept (2)

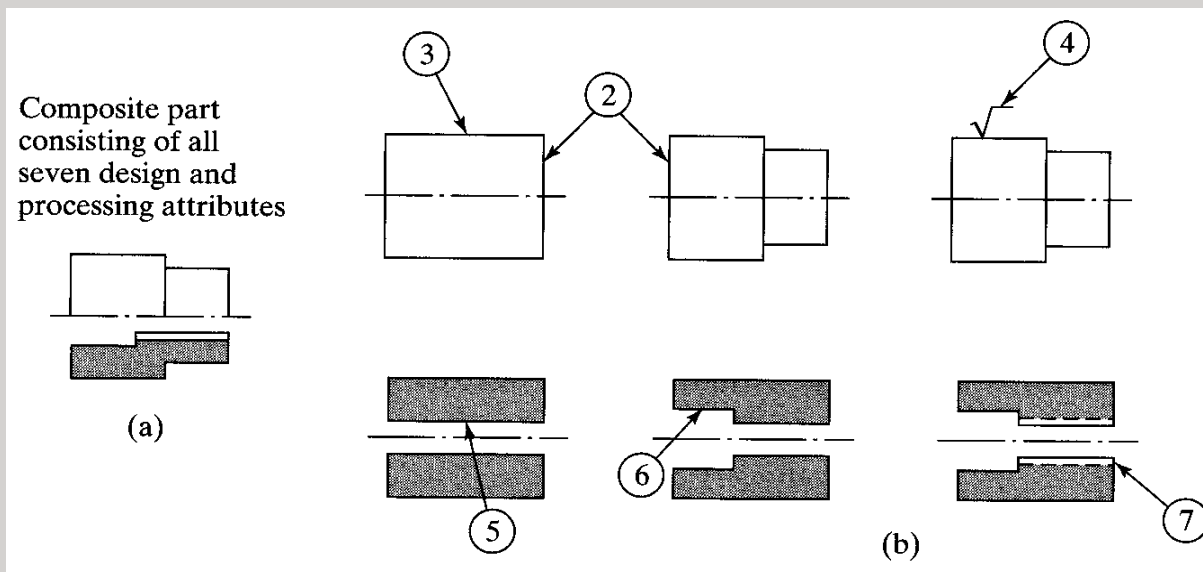

<i>Label</i>	<i>Design Feature</i>	<i>Corresponding Manufacturing Operation</i>
1	External cylinder	Turning
2	Cylinder face	Facing
3	Cylindrical step	Turning
4	Smooth surface	External cylindrical grinding
5	Axial hole	Drilling
6	Counterbore	Counterboring
7	Internal threads	Tapping

Machine Cell Design (1)

- Design of the machine cell is critical in cellular manufacturing. The cell design determines to a great degree the performance of the cell.

1. Types of machine cells and layouts

- GT manufacturing cells can be classified according to the number of machines and the degree to which the material flow is mechanized between machines.
- Four common GT cell configurations:
 - Single machine cell (Type I M)
 - Group machine cell with manual material handling (Type II M generally, Type III M less common)
 - Group machine cell with semi-integrated handling (Type II M generally, Type III M less common).
 - Flexible manufacturing cell or flexible manufacturing system (Type II A generally, Type III A less common)

Machine Cell Design (2)

- ⦿ **Single machine cell** consists of one machine plus supporting fixtures and tooling.
- ⦿ This type of cell can be applied to workparts whose attributes allow them to be made on one basis type of process, such as turning or milling.

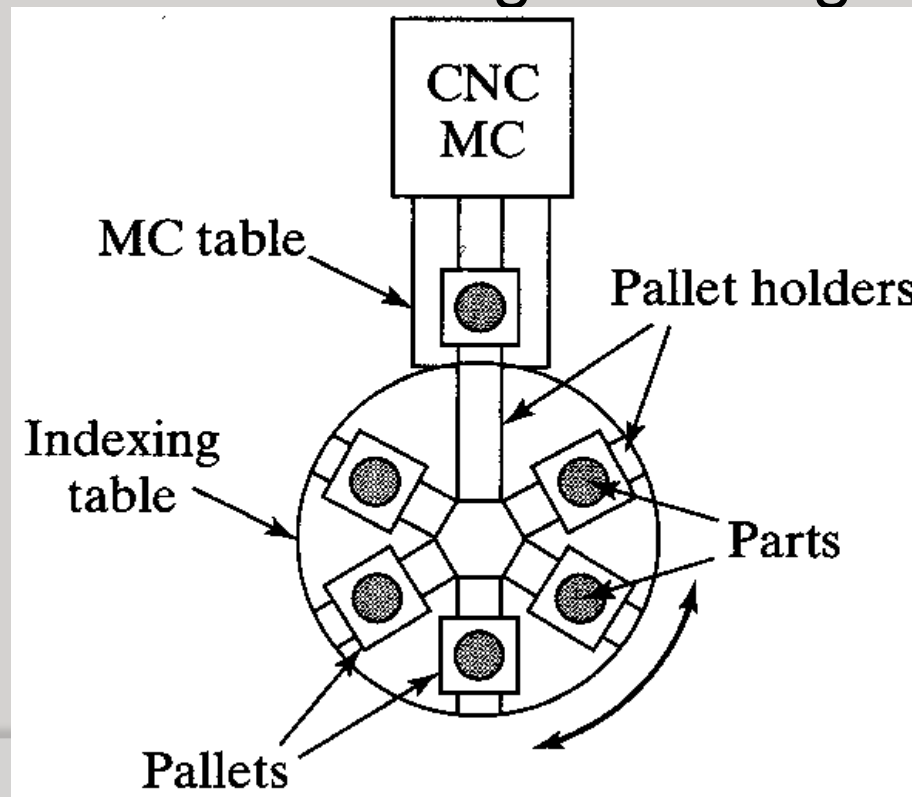

Machine Cell Design (3)

- **Group machine cell with manual handling** is an arrangement of more than one machine used collectively to produce one or more part families.
- There is no provision for mechanized parts movement between the machines in the cell. Instead, the human operators who run the cell perform the material handling function. The cell is often organized into a U-shaped layout.

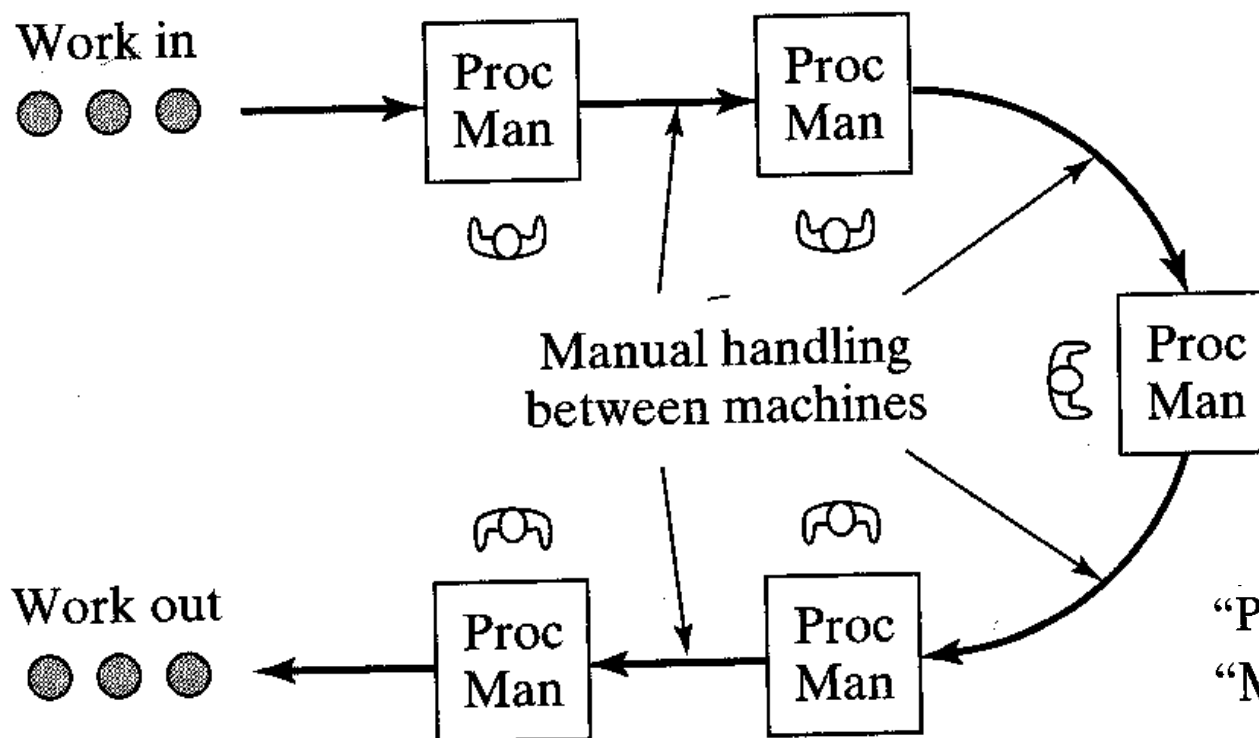

**U-shaped
Layout**

Machine Cell Design (4)

- Group machine cell with semi-integrated handling** uses a mechanized handling system, such as a conveyor, to move parts between machines in the cell.

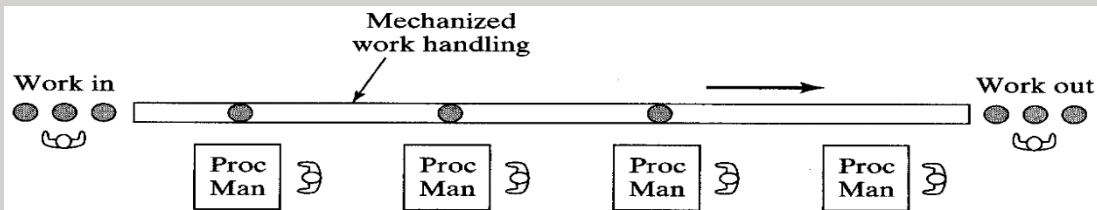

(a)

In-line Layout

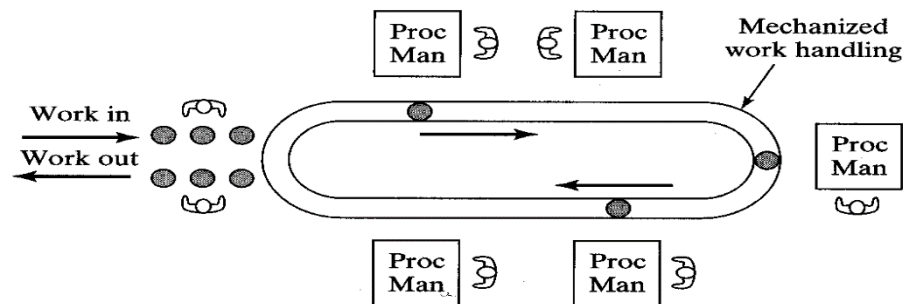

(b)

Loop Layout

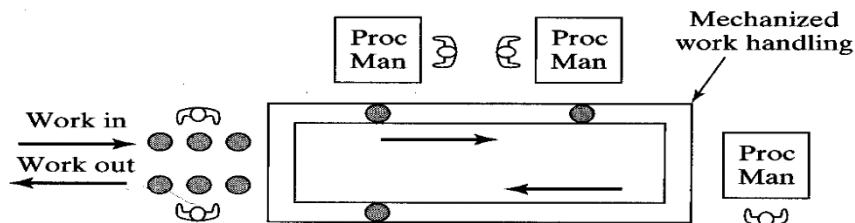

(c)

Rectangular Layout

Machine Cell Design (5)

- **Flexible manufacturing system** combines a fully integrated material handling system with automated processing stations.
- The FMS is the most highly automated of the Group Technology machine cells.

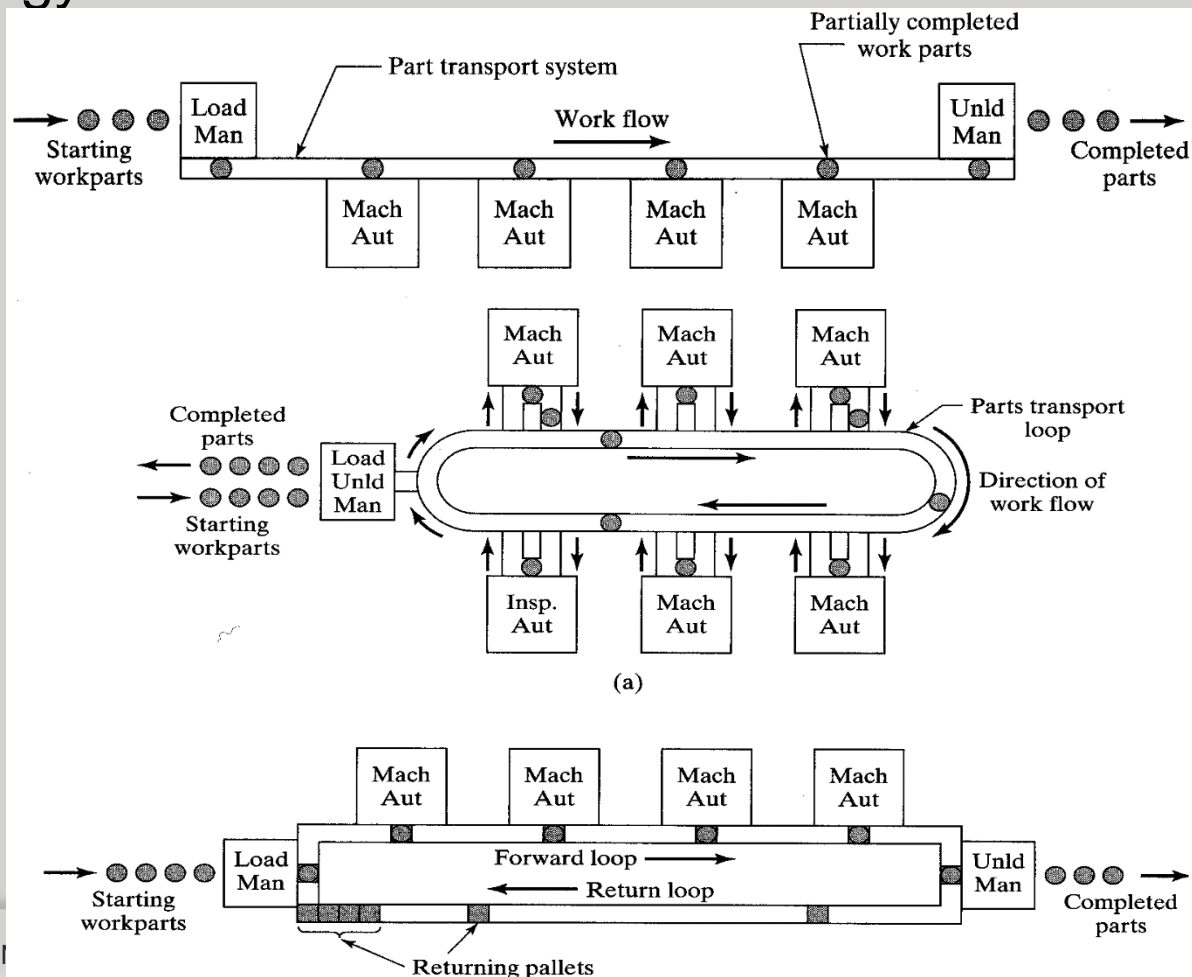

Machine Cell Design (6)

2. Types of part movements

- Determining the most appropriate cell layout depends on the routings of parts produced in the cell.
- Four types of part movement can be distinguished in a mixed model part production system.

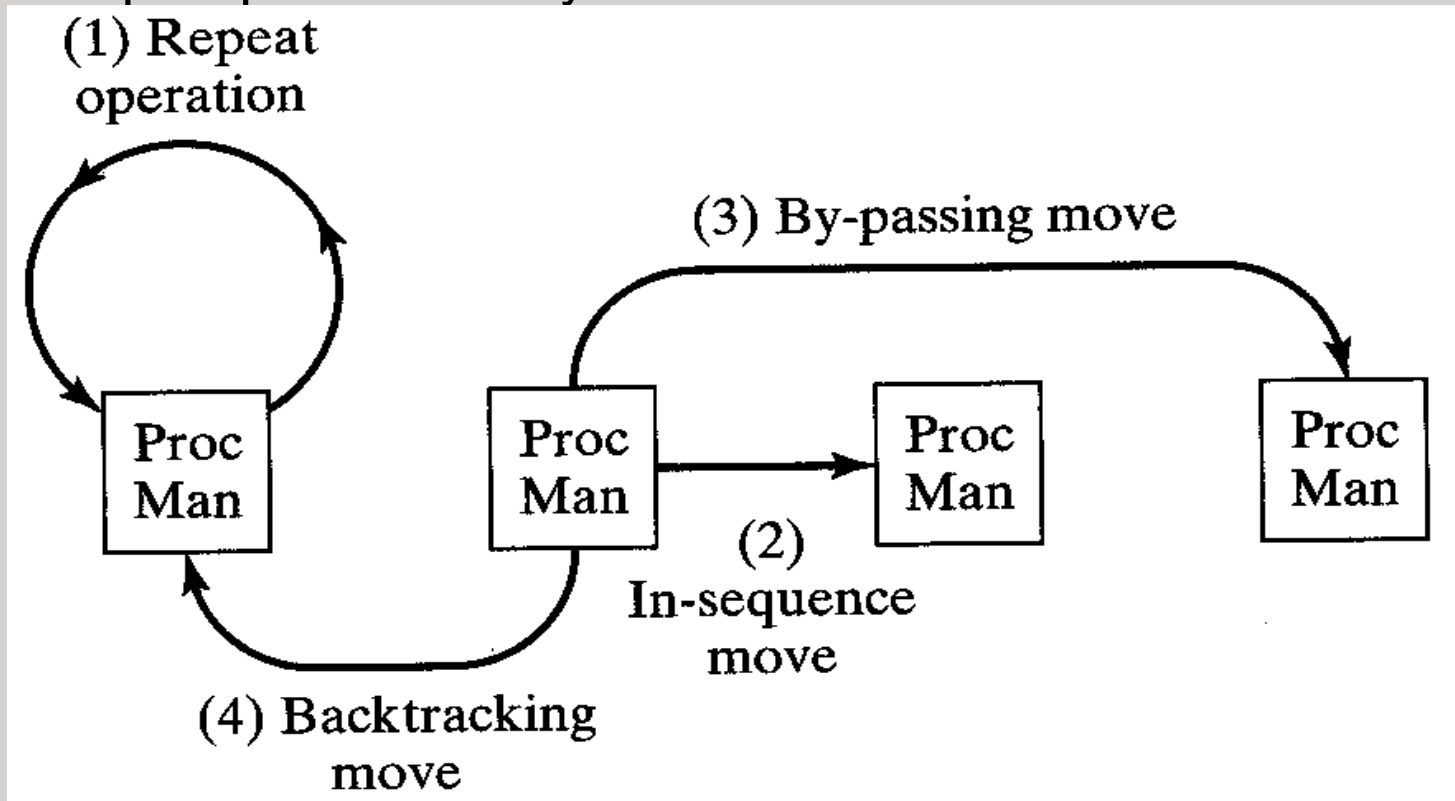

The forward flow of work is from left to right.

Machine Cell Design (7)

2. Types of part movements

1. **Repeat Operation**, in which a consecutive operation is carried out on the same machine, so that the part does not actually move.
2. **In-sequence move**, in which the part move from the current machine to an immediate neighbor in the forward direction.
3. **By-passing move**, in which the part moves forward from the current machine to another machine that is two or more machines ahead.
4. **Backtracking move**, in which the part moves from the current machine in the backward direction to another machine.

Machine Cell Design (8)

2. Types of part movements

In-sequence moves



In-line layout
U-shaped layout

Repeated operations



Multiple stations

By-passing moves



U-shaped layout

Backtracking moves



Loop or rectangular layout

Quantities Analysis in Cellular Manufacturing

- ◎ A number of quantities techniques have been developed to deal with problem areas in group technology and cellular manufacturing.
 1. Grouping parts and machines into families.
 2. Arranging machines in a GT cell.

- ◎ The two problem areas have been and still active research areas.

Grouping Parts and Machines by Rank Order Clustering (ROC) (1)

- The **Rank Order Clustering (ROC)** technique is specifically applicable in production flow analysis. It is an efficient and easy to use algorithm for grouping machines into cells.
- The algorithm, which is based on sorting rows and columns of the machine-part incidence matrix, is given below.
 1. Assign binary weight and calculate a decimal weight for each row using the formula

Decimal weight for row

$$i = \sum_{p=1}^m b_{ip} 2^{m-p}$$

where:

m is the number of row and

b is a binary number (0 or 1)

Grouping Parts and Machines by Rank Order Clustering (ROC) (2)

- Rank the rows from top to bottom in order of decreasing decimal weight values
- Assign binary weight and calculate a decimal weight for each column using the formula

Decimal weight for column

$$j = \sum_{p=1}^n b_{pj} 2^{n-p}$$

where:

n is the number of column and b is a binary number (0 or 1)

- Rank the column from left to right in order of decreasing decimal weight values
- Continue preceding steps until there is no change in the position of each element in each row and column

Grouping Parts and Machines by Rank Order Clustering (ROC) (3)

◉ Example

- Apply the rank order clustering technique to the part-machine incidence matrix shown below.

	Parts								
Machines	A	B	C	D	E	F	G	H	I
1	1			1				1	
2					1				1
3			1		1				1
4		1				1			
5	1							1	
6			1						1
7		1				1	1		

Grouping Parts and Machines by Rank Order Clustering (ROC) (4)

Example Solution

- First Iteration (Step 1)

Binary Values	2^8	2^7	2^6	2^5	2^4	2^3	2^2	2^1	2^0		
	Parts									Decimal	
Machines	A	B	C	D	E	F	G	H	I	Equivalent	Rank
1	1			1				1		290	1
2					1				1	17	7
3			1		1				1	81	5
4		1				1				136	4
5	1							1		258	2
6			1						1	65	6
7		1				1	1			140	3

Grouping Parts and Machines by Rank Order Clustering (ROC) (5)

Example Solution

- Second Iteration (Steps 2 & 3)

Machines	Parts									Binary Values
	A	B	C	D	E	F	G	H	I	
1	1			1				1		2^6
5	1							1		2^5
7		1				1	1			2^4
4		1				1				2^3
3			1		1				1	2^2
6			1						1	2^1
						1			1	2^0
Decimal Equivalent	96	24	6	64	5	24	16	96	7	
Rank	1	4	8	3	9	5	6	2	7	

Grouping Parts and Machines by Rank Order Clustering (ROC) (6)

Example Solution

- Final Solution (Steps 4 & 5)

Machines	Parts								
	A	H	D	B	F	G	I	C	E
1	1	1	1						
5	1	1							
7				1	1	1			
4				1	1				
3							1	1	1
6							1	1	
2							1		1

Arranging Machines in a GT Cell (1)

- After part-machine grouping have been identified by rank order clustering, the next problem is to *organize the machines into the most logical arrangement.*

- **Hollier Method.**

This method uses the sums of flow “From” and “To” each machine in the cell. The method can be outlined as follows

1. ***Develop the From-To chart from part routing data.*** The data contained in the chart indicates numbers of part moves between the machines in the cell.
2. ***Determine the “From” and “To” sums for each machine.*** This is accomplished by summing all of the “From” trips and “To” trips for each machine.
 - ❑ The “**From**” sum for a machine is determined by adding the entries in the corresponding row.
 - ❑ The “**To**” sum is found by adding the entries in the corresponding column.

Arranging Machines in a GT Cell (2)

◉ Hollier Method (contd).

3. **Assign machines to the cell based on minimum “From” or “To” sums.**
The machine having the smallest sum is selected.

- ❑ If the minimum value is a “To” sum, then the machine is placed at the beginning of the sequence.
- ❑ If the minimum value is a “From” sum, then the machine is placed at the end of the sequence.

Tie breaker

- ❑ If a tie occurs between minimum “To” sums or minimum “From” sums, then the machine with the minimum “From/To” ratio is selected.
- ❑ If both “To” and “From” sums are equal for a selected machine, it is passed over and the machine with the next lowest sum is selected.
- ❑ If a minimum “To” sum is equal to a minimum “From” sum, then both machines are selected and placed at the beginning and end of the sequence, respectively

4. **Reformat the From-To chart.** After each machine has been selected, restructure the From-To chart by eliminating the row and column corresponding to the selected machine and recalculate the “From” and “To” sums.

5. **Repeat steps 3 and 4 until all machines have been assigned.**

Arranging Machines in a GT Cell (3)

Example.

Suppose that four machines, 1, 2, 3, and 4 have been identified as belonging in a GT machine cell. An analysis of 50 parts processed on these machines has been summarized in the From-To chart presented below. Additional information is that 50 parts enter the machine grouping at machine 3, 20 parts leave after processing at machine 1, and 30 parts leave after machine 4. Determine a logical machine arrangement using Hollier method.

From-To Chart

		<i>To:</i>			
		<i>1</i>	<i>2</i>	<i>3</i>	<i>4</i>
<i>From:</i>	<i>1</i>	0	5	0	25
	<i>2</i>	30	0	0	15
	<i>3</i>	10	40	0	0
	<i>4</i>	10	0	0	0

Arranging Machines in a GT Cell (4)

○ First Iteration.

	To:	1	2	3	4	"From" Sums
From: 1		0	5	0	25	30
2		30	0	0	15	45
3		10	40	0	0	50
4		10	0	0	0	10
"To" sums		50	45	0	40	135

Arranging Machines in a GT Cell (5)

- Second iteration with machine 3 removed.

<i>To:</i>	1	2	4	"From" Sums
<i>From:</i> 1	0	5	25	30
2	30	0	15	45
4	10	0	0	10
"To" sums	40	5	40	

Arranging Machines in a GT Cell (6)

- Third iteration with machine 2 removed.

	<i>To:</i>	<i>1</i>	<i>4</i>	<i>"From" Sums</i>
<i>From:</i>	<i>1</i>	0	25	25
	<i>4</i>	10	0	10
<i>"To" sums</i>		10	25	

- The resulting machine sequence **3 → 2 → 1 → 4**

Arranging Machines in a GT Cell (7)

- ⦿ The flow diagram for machine cell in the Example is shown below. Flow of parts into and out of the cells has also been included

