



**Παρουσιάσεις για το Μάθημα
Ασύρματων και Κινητών Τηλεπικοινωνιών
του ΔΜΠΣ στο ΕΚΠΑ**

Δρ. Χάρης Μ. Στελλάκης
hstellakis@gmail.com

Αθήνα, 2024



CDMA Systems



Multiple Access Techniques

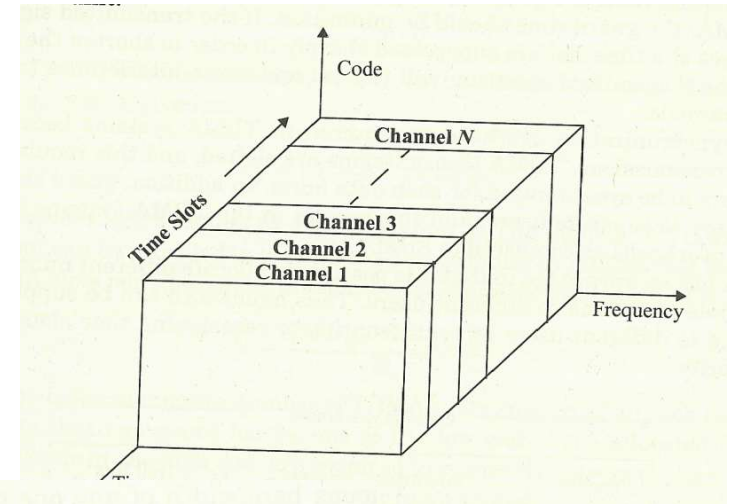
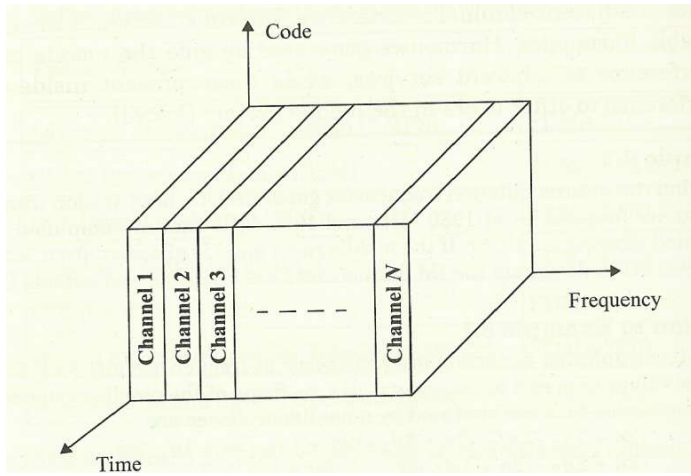

The party effect

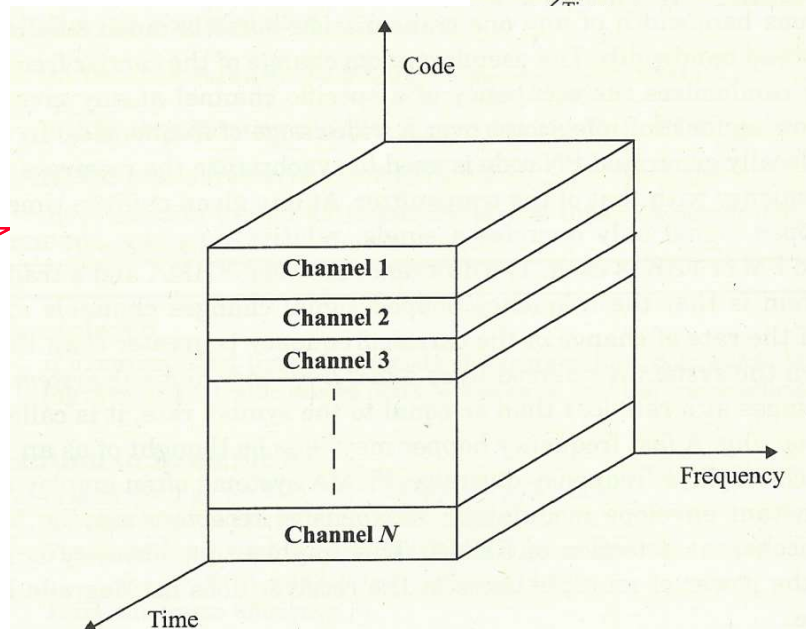



FDMA/TDMA vs CDMA

FDMA / TDMA

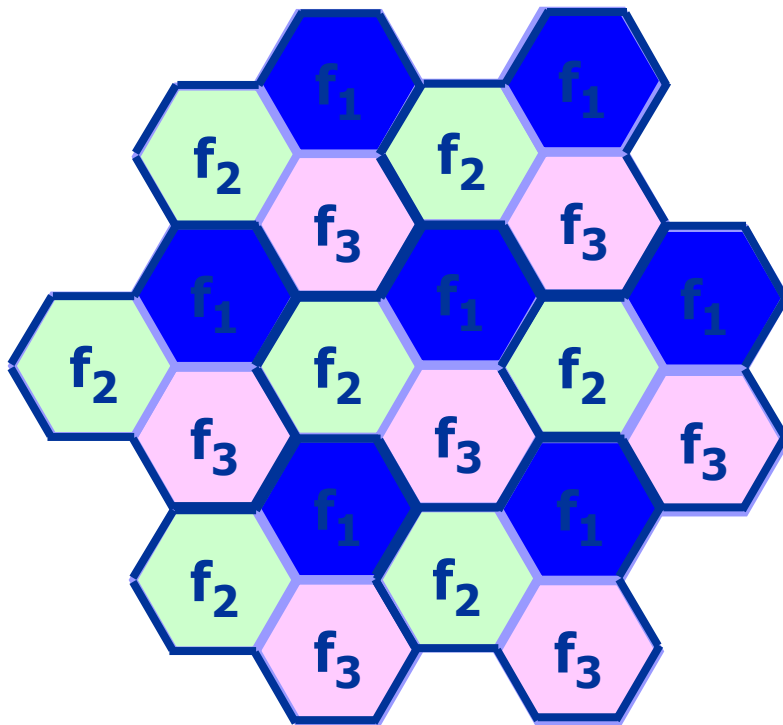

In case of 3 cell repetition
Design objective is
frequency allocation.

CDMA

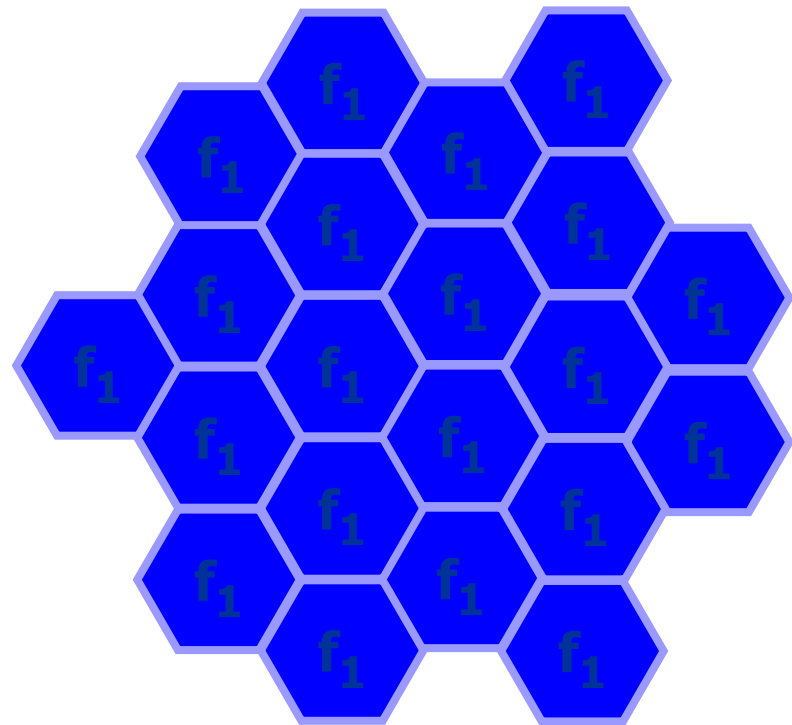

Same frequency in all area.



QoS Network Specifications

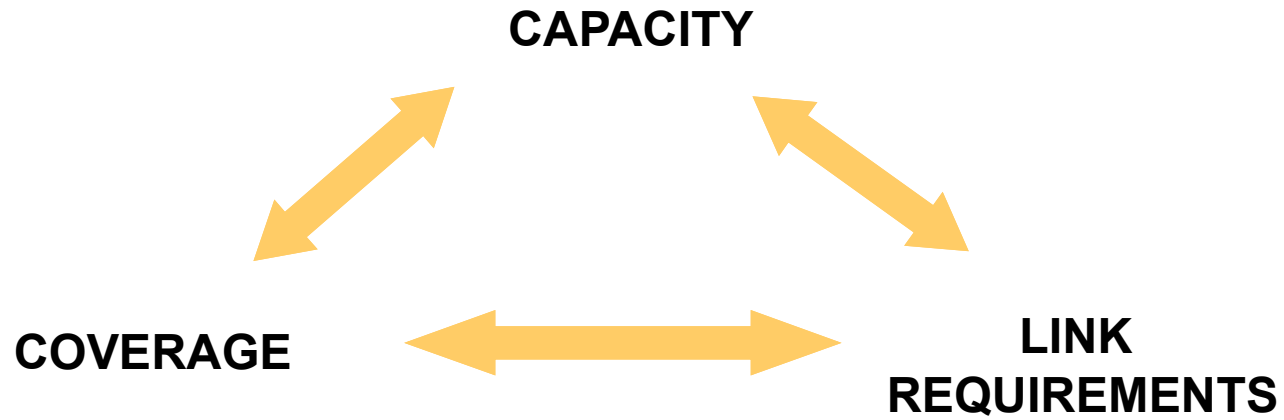



Code Divison Multiple Access Schemes

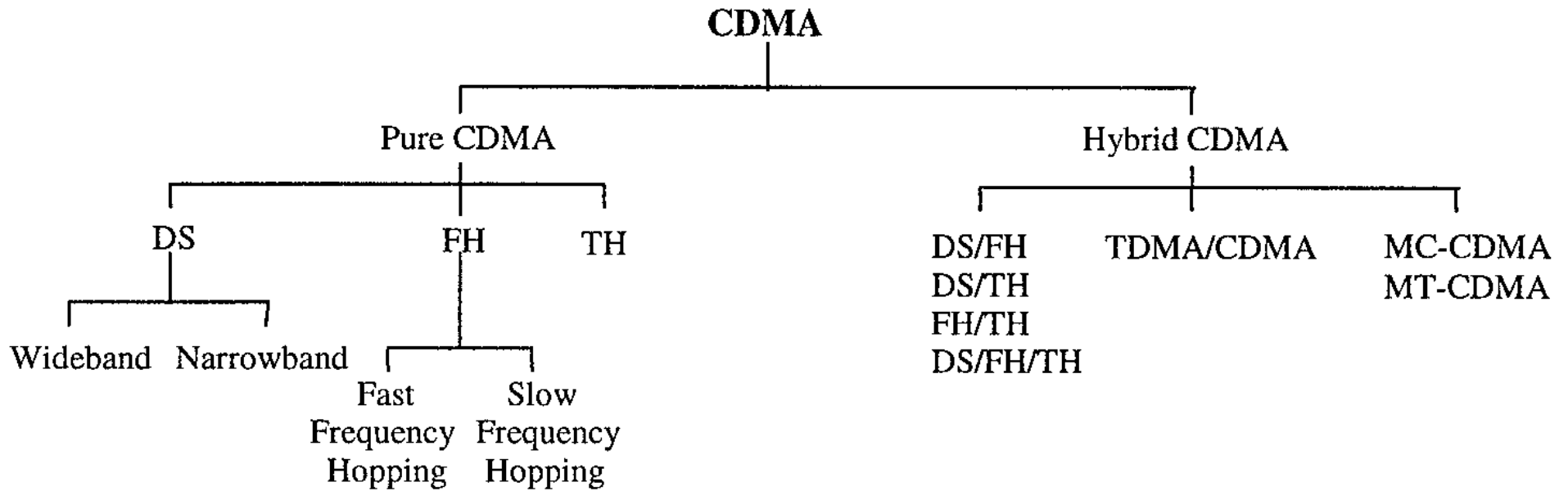



DS-CDMA System

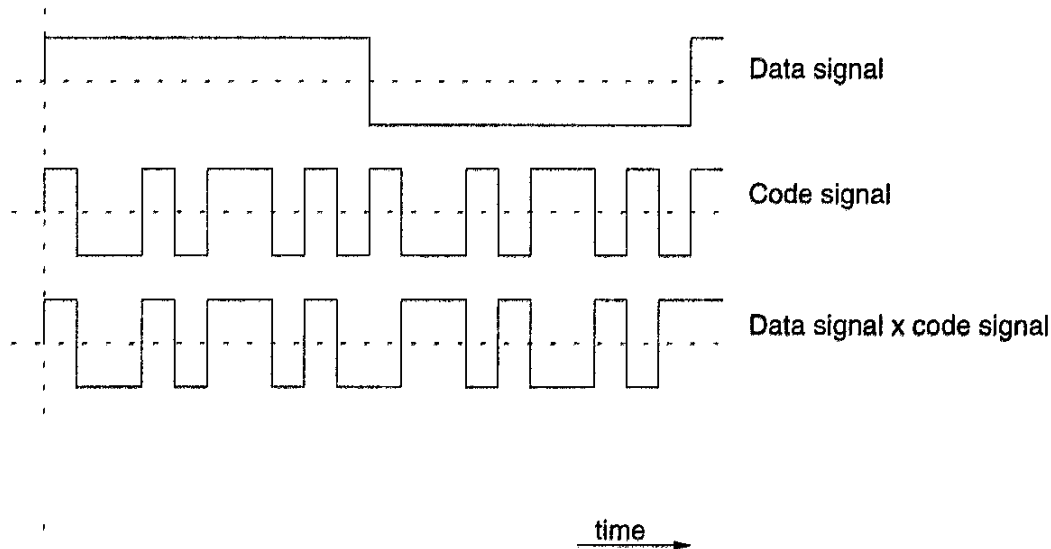
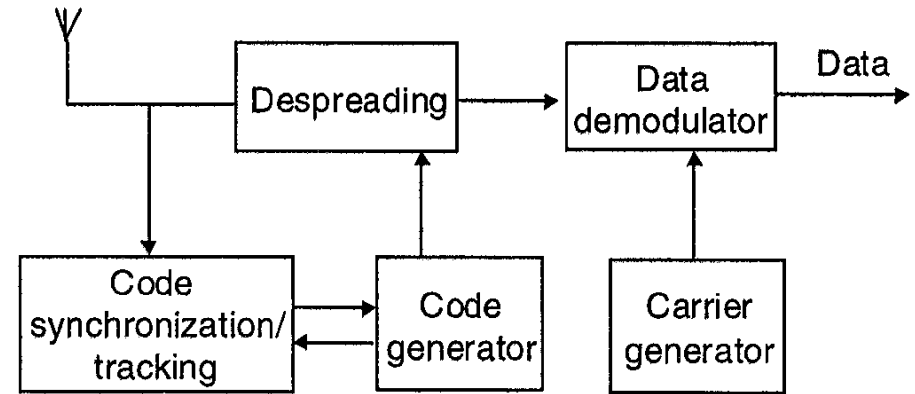
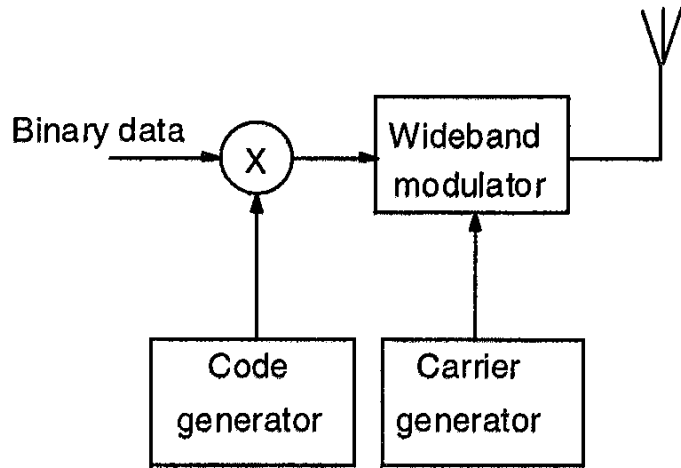

$$\left(\frac{S}{N} \right)_{user} = \frac{E_b * R}{N_0 * W} = (E_b / N_0) / G_p$$

Processing Gain



Data Spreading & Recovery

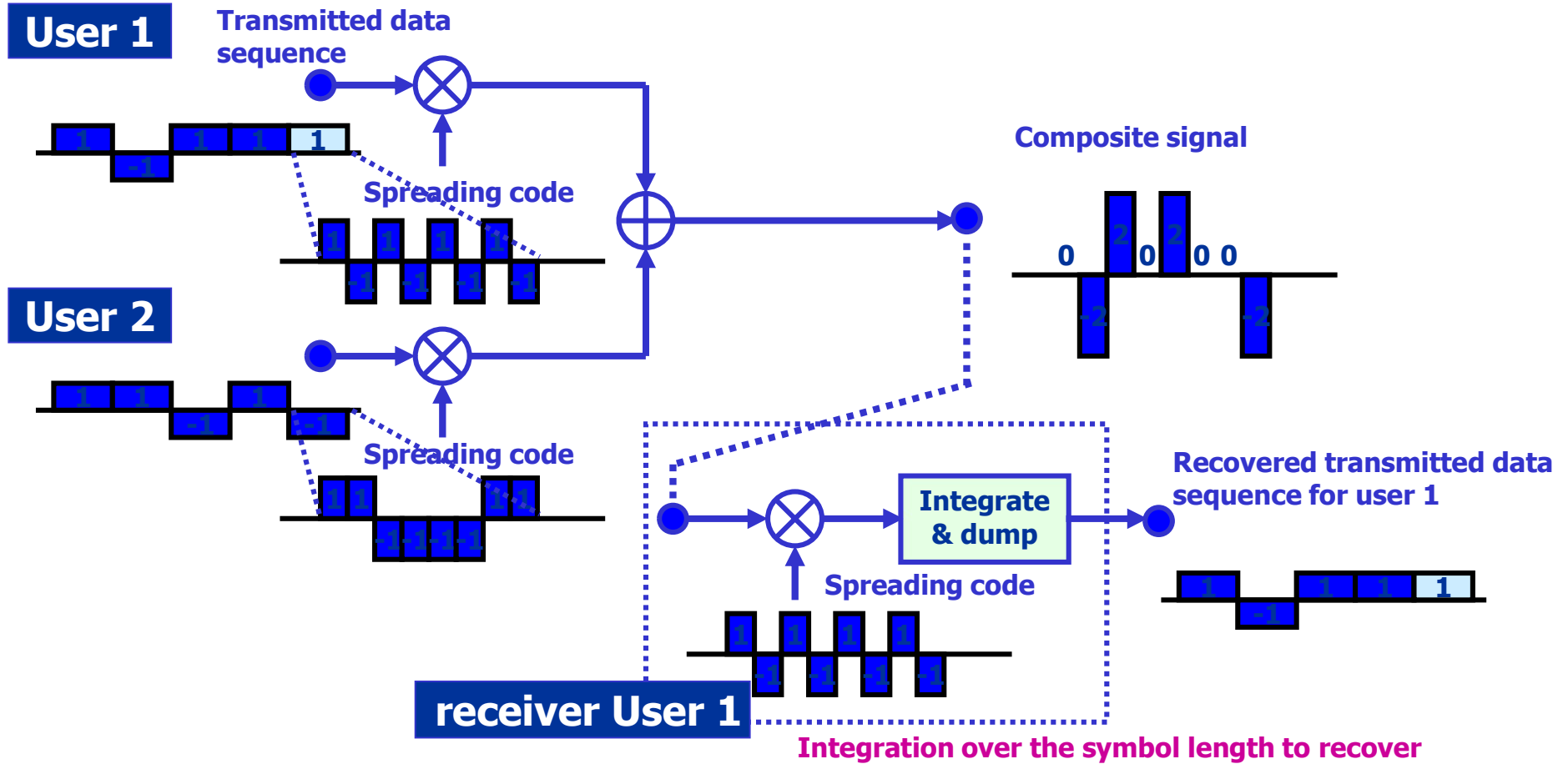



Signal Handover

- ❖ **Handover (or handoff) facilitates «make before break» calls**
 - Soft between different BSs
 - Softer between same BS but different sectors
 - Hard between different frequencies
- ❖ **It comprises an essential attribute that leads to other-user interference reduction (due to macro diversity)**
- ❖ **At the expense of system resources**

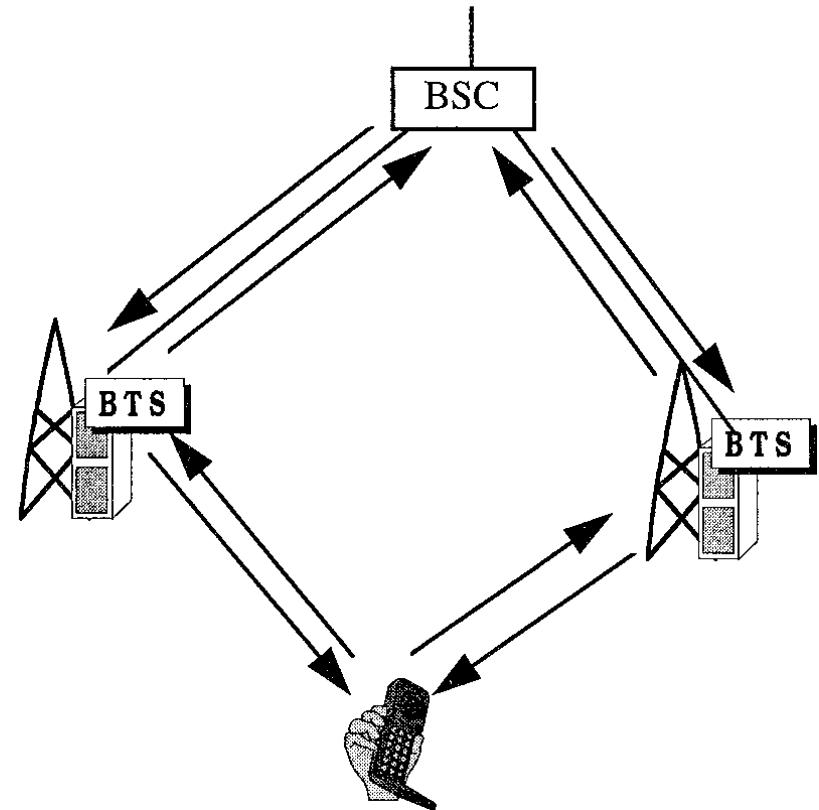



Macro Diversity

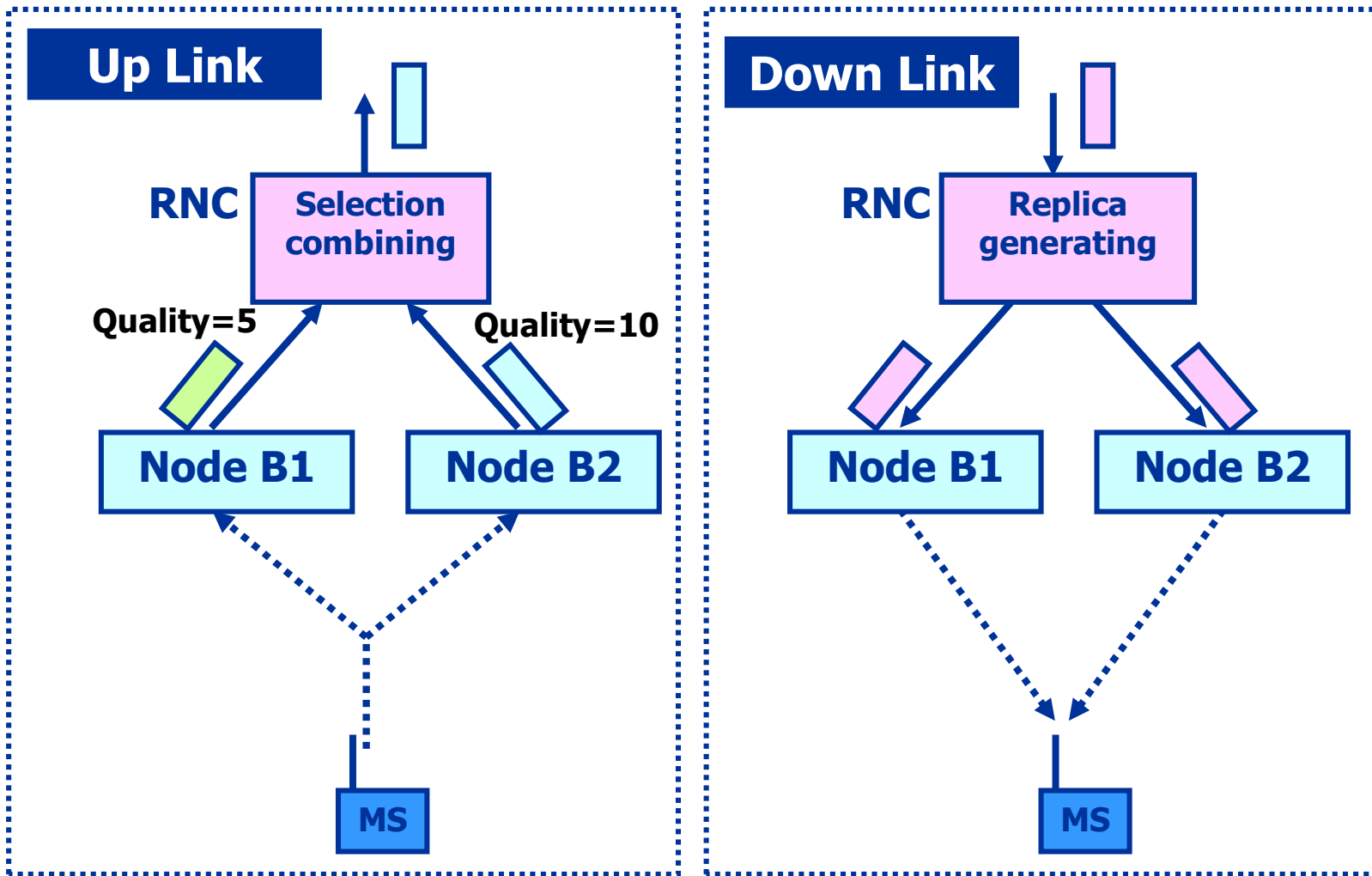



Handover Statistics

From field trials

Handoff Type	Mean, percent	Standard Deviation, percent
Softer	62.80	19.14
Two-way soft	6.52	19.05
Soft-softer	4.42	7.90
Three-way soft	0.40	0.82
Three-way softer	0.20	0.42
No handoff	25.66	10.80

$$Avg Channels_{user} = 1 + (2 - 1) * (6,52\% + 4,42\%) + (3 - 1) * 0,4\% = 1,12$$

12% handoff resource overhead



Channel Element “Pooling”

CHANNEL ELEMENT CALCULATION

Example

	Speech 8 Kbps	Data 144 Kbps
Erlang/sector	30 Erl	8 Erl
Soft handover overhead	30%	30%
Total traffic (3 sectors)	117 Erl	31.2 Erl
Number of channel elements/sector from Erlang B table, pooling taken into account	44	14
Channel elements for pilot and common control channels	2	2
Total number of channel elements	46	16

❖ Required CE / sector (without HO):

— 90 Erl (@ 2% blk) → 102,9 CE → 34,3 CE / sector

❖ Required CE / sector (with HO):

— 117 Erl (@ 2% blk) → 130 CE → 43,3 CE / sect

❖ No CE pooling (with HO) :

— 39 Erl / sect (@ 2% blk) → 49 CE / sect

26,2% CE overhead
due to HO

11,6% CE reduction
due to Pooling



Primary Server Handover

- ❖ **Primary server (BS) is selected with respect to minimum Tx required by MS to close the link**

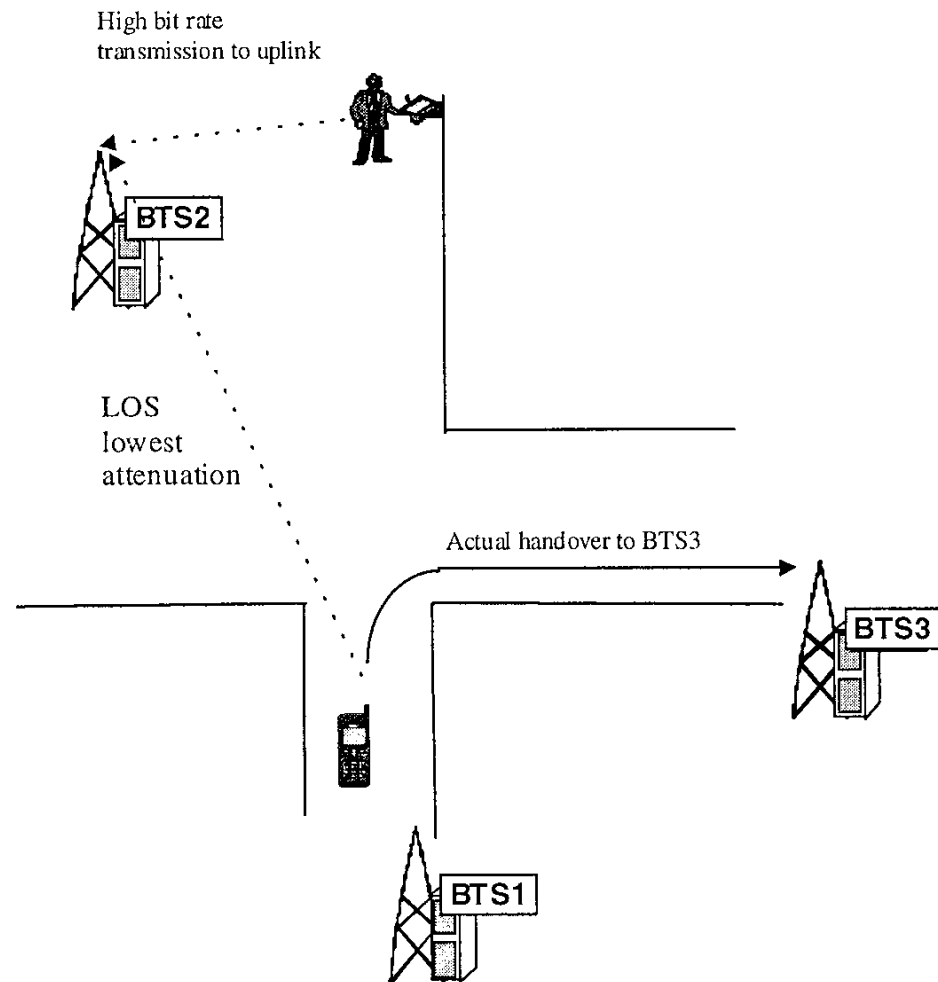



RAKE Receiver turns multipath into diversity

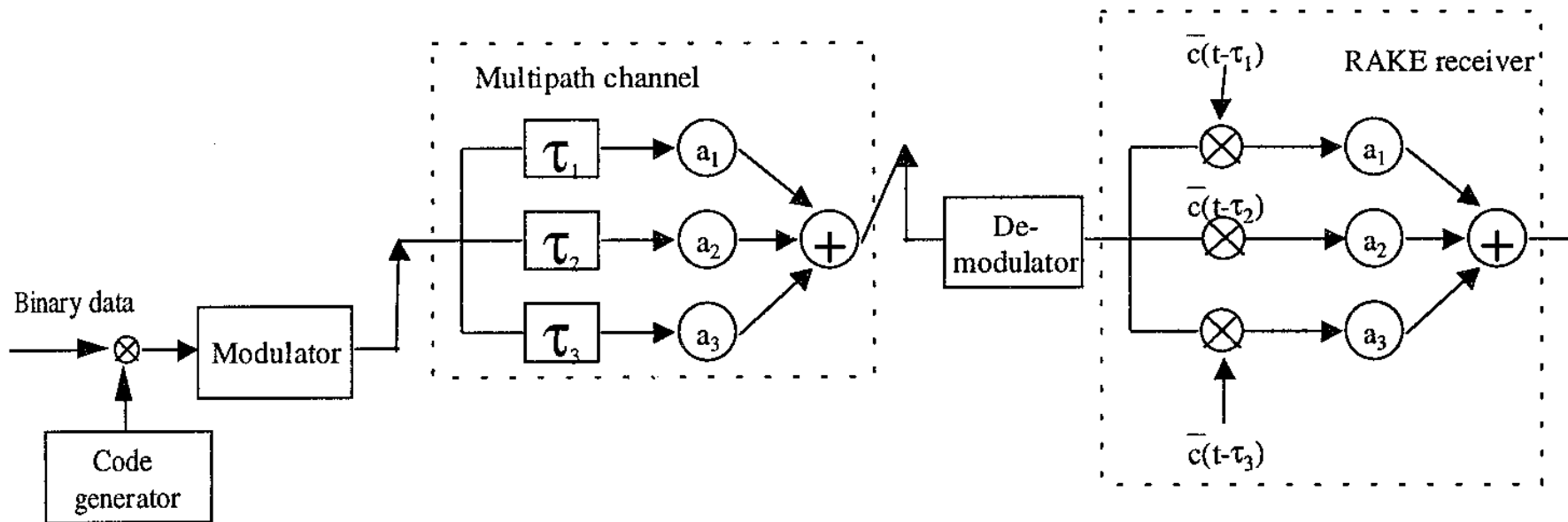



Power Control

- ❖ **Power control is applied to both links to reduce *other user interference***
- ❖ **At the Up-link**
 - All signals should arrive at the BS with the same mean power to mitigate the «near-far effect»
 - Power control info is transmitted through the Forward (Down-) link
 - The MS adjusts its Tx power accordingly
- ❖ **At the Down-link**
 - The MS (especially those at the cell edge) suffer from other-cell interference
 - Quality of signal received (BER/ FER) is transmitted back to the BS to adjust the Tx power accordingly
- ❖ ***The performance of the power control mechanisms dictates system capacity***



Power Control

Near – far problem

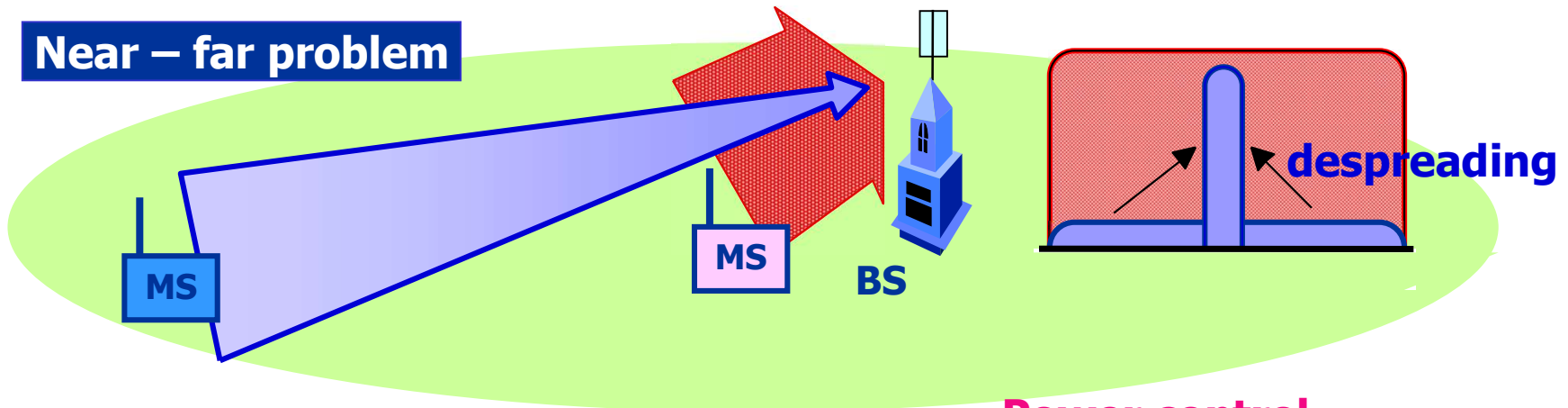

Power control

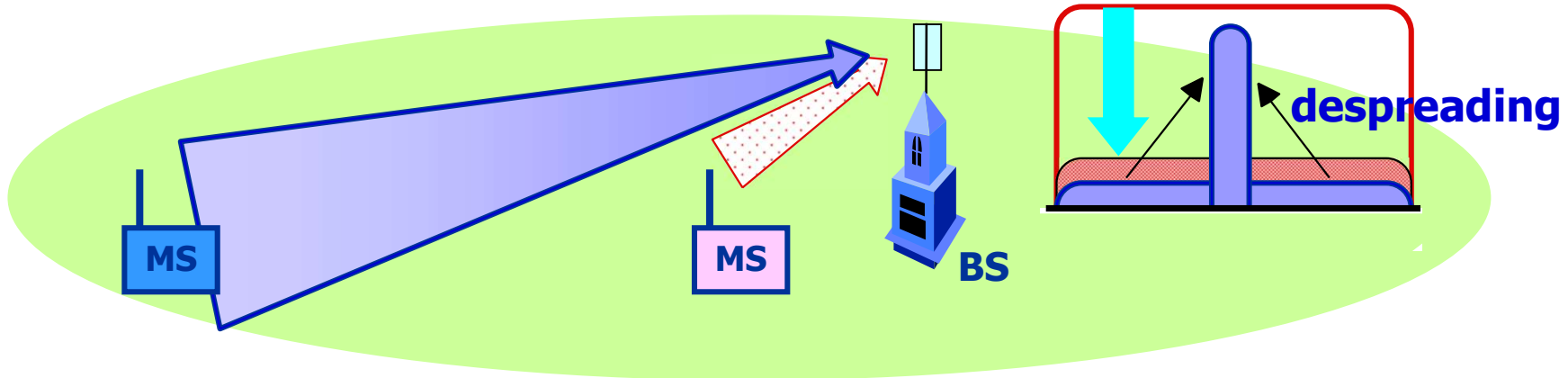

PC
is essential



**Minimizes
the Tx power**



**Increases
the system capacity**



Handover Procedure

It determines the BSs that serve each mobile

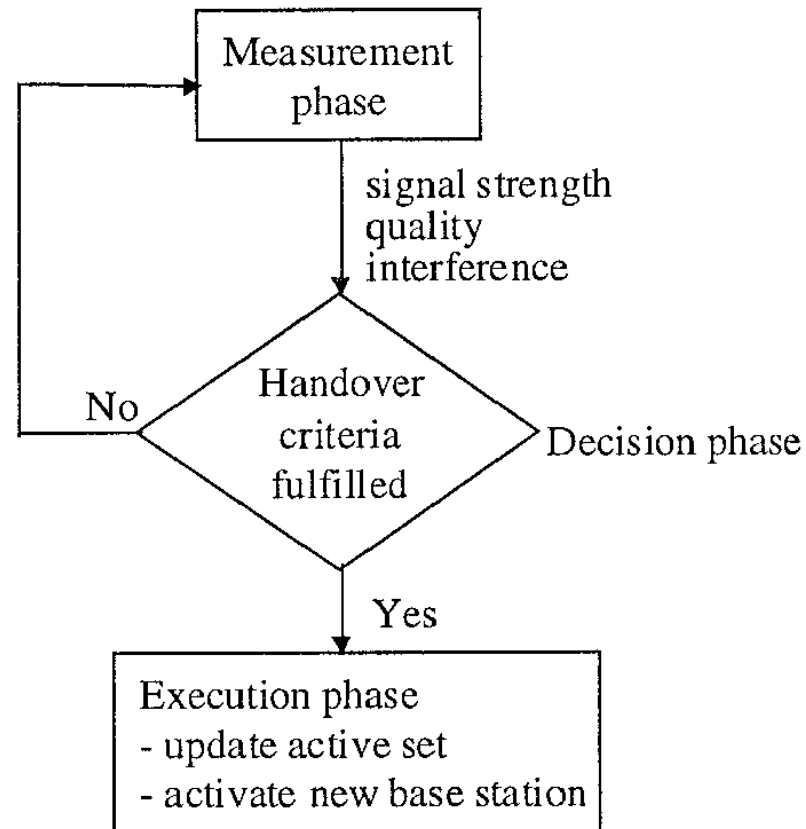



Handover Decision Mechanism

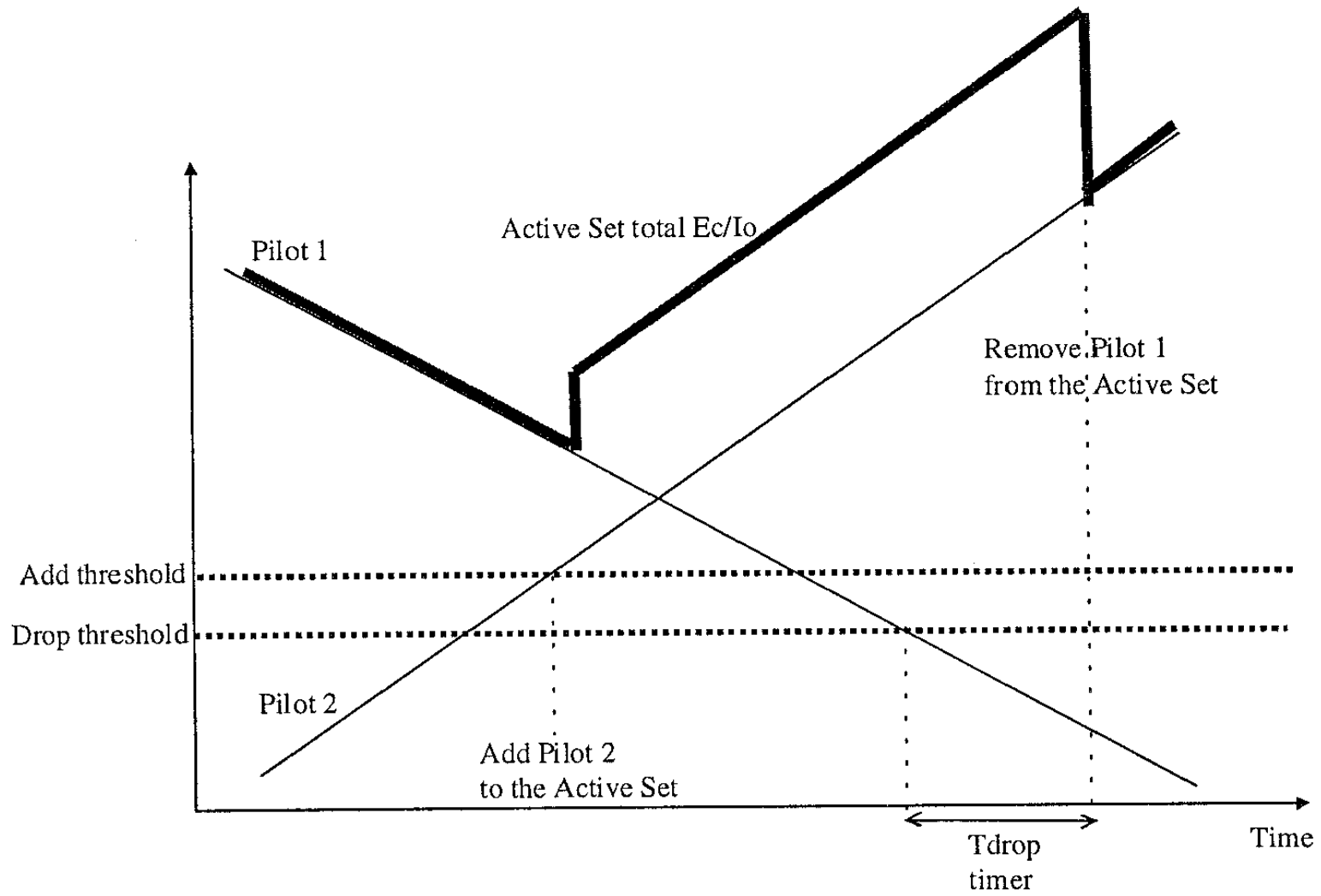

Active Set: The set of BS's in HO mode



System Coverage

- ❖ **Coverage is not just a matter of max path loss between the BS and MS**
 - It is a different issue at both links
- ❖ **At the Uplink:**
 - A MS is covered as long as its max Tx power can «close the link»
 - A highly loaded system results to a high Other-Cell Interference at the receiving BS → Reduced Coverage
 - Increase of the MS Tx power increases the Other-Cell interference
- ❖ **At the Downlink:**
 - A MS is covered as long as it can clearly detect a BS over the interference
 - A highly loaded system results to a high interference at the DL → Reduced Coverage
 - Increase of the BS Tx power increases the interference to other users
- ❖ **Systems may be UL- or DL- limited**
- ❖ **System coverage is attained when both links are closed, so ...**
 - *link balancing is very important*



Cell Breathing

- ❖ **As the loading within a cell is increased, the BS receiver Noise Floor appears to rise**
- ❖ **The MS must transmit at higher power to overcome the increased interference**
- ❖ **At some point, the MS Tx power reaches its max limit and the MS cannot reach the BS**
 - *the cell shrinks*
- ❖ **MS at the cell boundary are connected to other neighboring cells**



Cell Breathing

Lightly Loaded
Central Cell

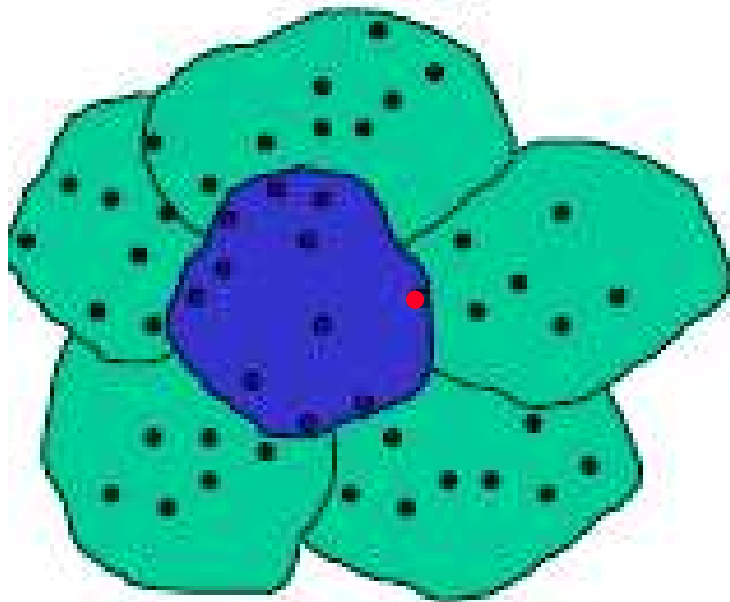

Heavily Loaded
Central Cell

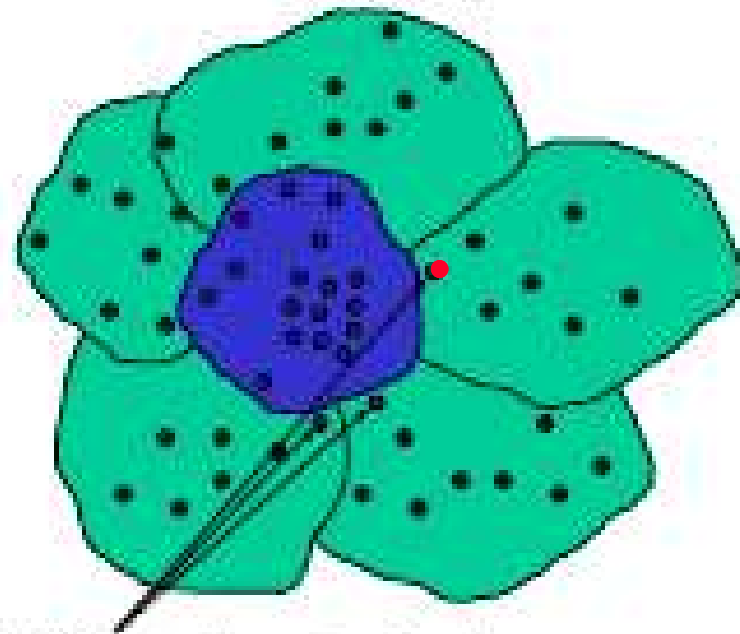

Mobiles on the cell perimeter are shed to neighbouring cells



UpLink Capacity

$$C = \frac{(1 - \eta) F_r (W / R_b) F(P_B, \sigma_p)}{\rho (E_b / I_0)}$$

1/Rise above Thermal

System Loading

$$Freq\ Reuse = \frac{I_{in}}{I_{in} + I_{oc}}$$

Service Activity Factor

Dependency on Pb and Power Control



System Loading

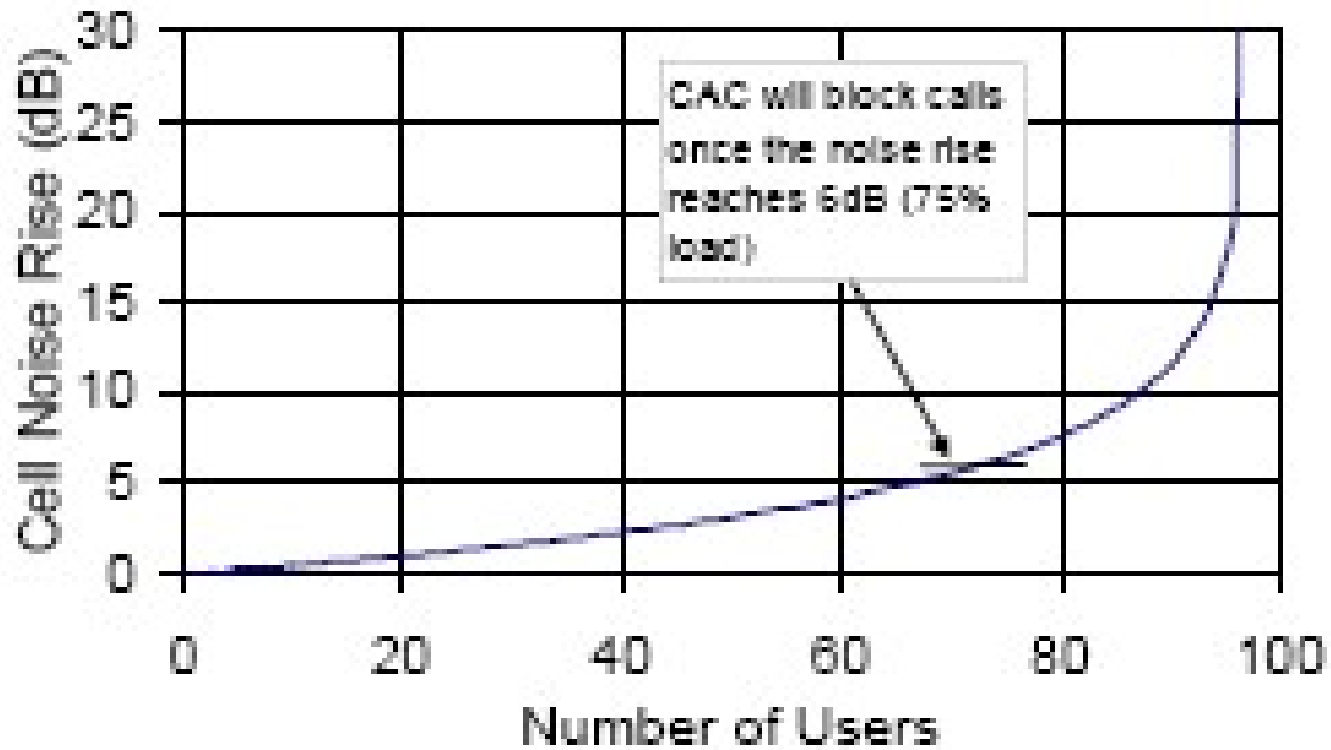



Frequency Reuse

$$F_r = \frac{\sum_{\text{all users } i} I_{i0}}{\sum_{\text{all users } i} I_{i0} + \sum_{\substack{\text{all users } k, \\ k \neq i}} \sum_{\substack{\text{all cells } j, \\ j \neq 0}} I_{kj}}$$

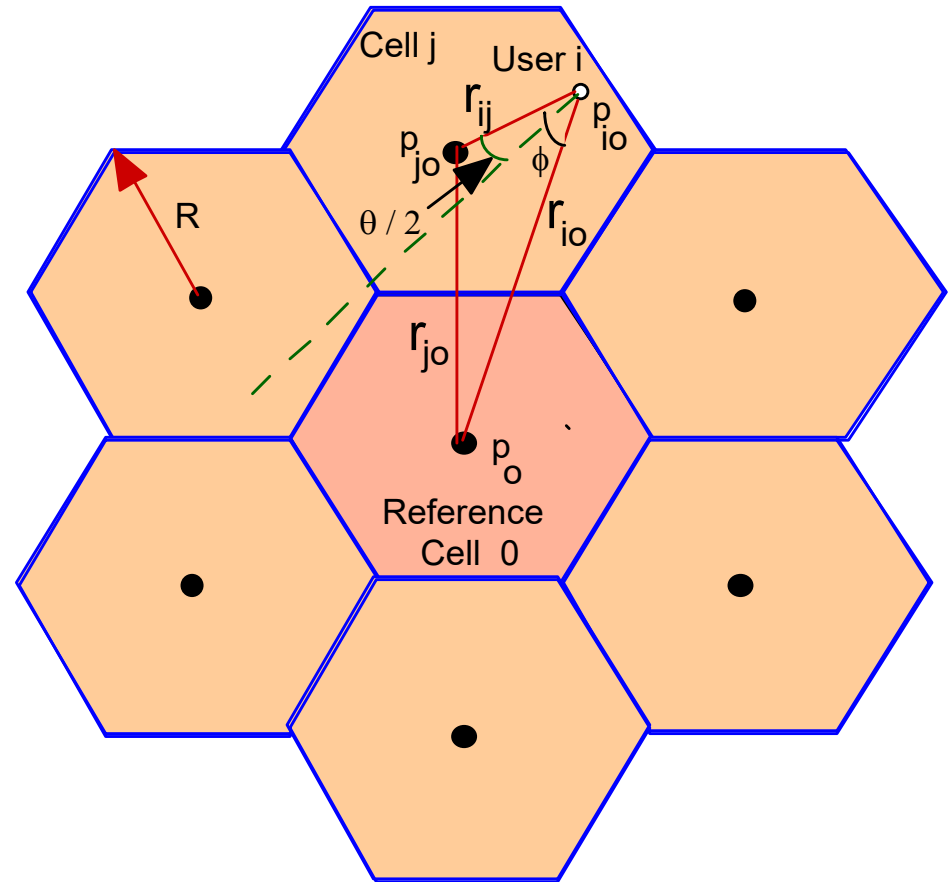



Downlink Performance

❖ Capacity is determined stochastically based on

- Outage Probability
- Link requirement
- Maximum Tx power

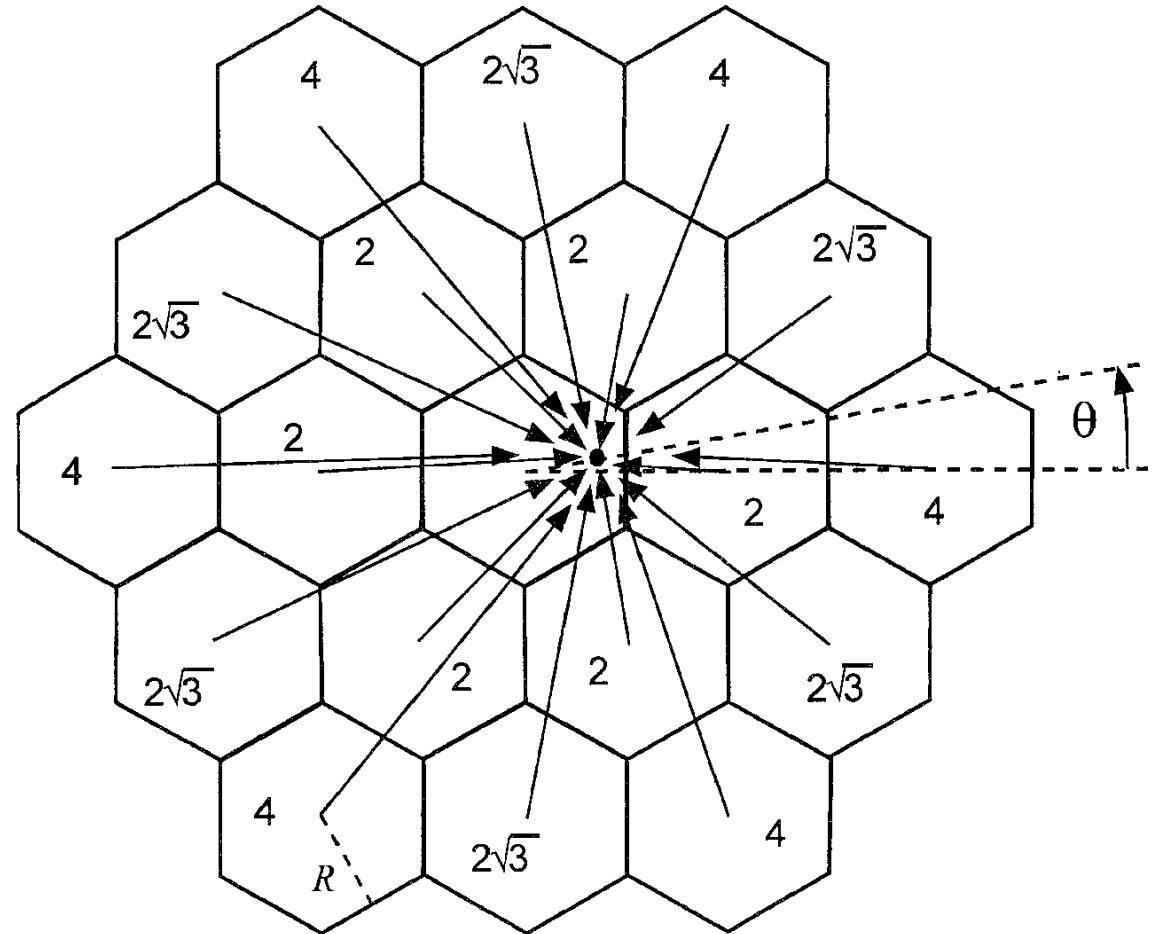



Link Balancing

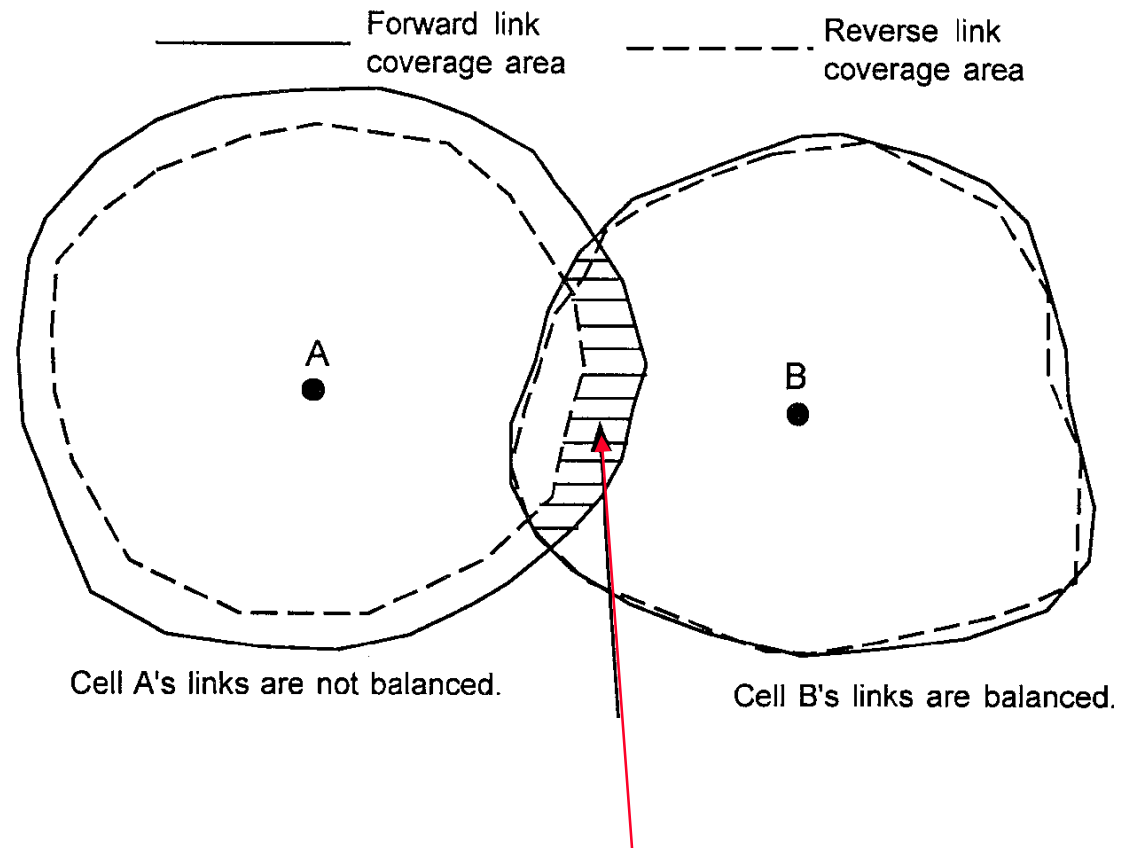

- Handovers may occur from B to A but
- A's Uplink cannot support a call



Link Balancing

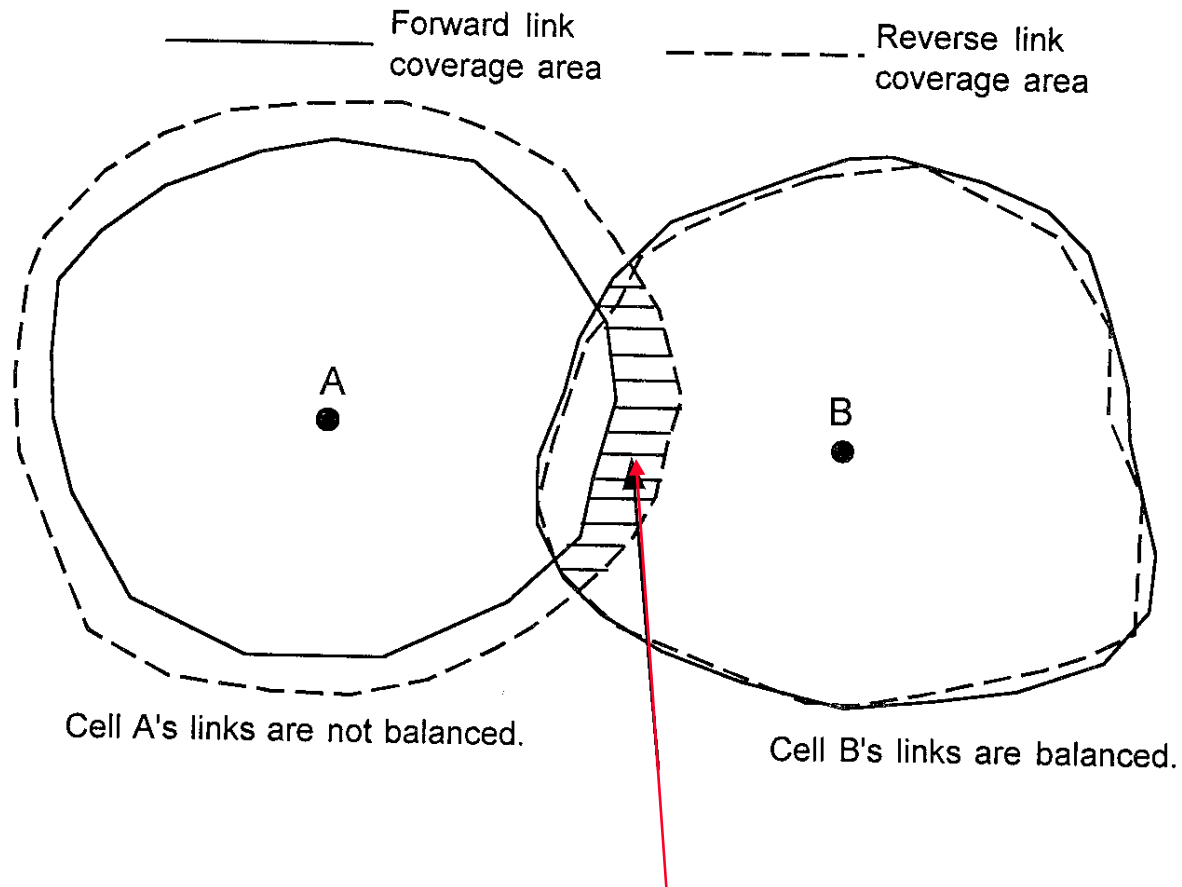

- Handovers do not occur from B to A so
- The MS generate interference to cell A



Βιβλιογραφία

- ❖ T. Rappaport, *Wireless Communications – Principles & Practice*, Prentice Hall PTR
- ❖ R. Freeman, *Radio System Design for Telecommunications*, Wiley Series in Telecommunications
- ❖ M. Clark, *Wireless Access Networks*, Wiley
- ❖ J. Laiho & A. Wacker & T. Novosad, *Radio Network Planning and Optimization for UMTS*, Wiley
- ❖ A. Viterbi, *CDMA – Principles of Spread Spectrum Communication*, Addison-Wesley Wireless Communications Series
- ❖ J. Sam Lee & L.E. Miller, *CDMA Systems Engineering Handbook*, Artech House
- ❖ V. Garg & K. Smolik & J. Wilkes, *Applications of CDMA in Wireless / Personal Communications*, Prentice Hall PTR
- ❖ S. Glisic & B. Vucetic, *Spread Spectrum CDMA Systems for Wireless Communications*, Artech House
- ❖ T. Ojanpera & R. Prasad, *Wideband CDMA for 3rd Generation Mobile Communications*, Artech House
- ❖ W. Webb, *Introduction to Wireless Local Loop*, Artech House
- ❖ D. Roddy, *Satellite Communications*, Mc Graw Hill
- ❖ S. Ohmori & H. Wakana & S. Kawase, *Mobile Satellite Communications*, Artech House