

The South Stoa at Corinth
Design, Construction and Function of the Greek Phase

David Richard Scahill

A thesis submitted for the degree of Doctor of Philosophy

University of Bath

Department of Architecture and Civil Engineering

2012

COPYRIGHT

Attention is drawn to the fact that copyright of this thesis rests with its author. A copy of this thesis has been supplied on condition that anyone who consults it is understood to recognize that its copyright rests with the author and they must not copy it or use material from it except as permitted by law or with the consent of the author.

This thesis may be made available for consultation within the University Library and may be photocopied or lent to other libraries for the purposes of consultation.



Table of Contents

Illustrations	v
Acknowledgements	xii
Abstract	1
Methodology	3
Part I: Introduction	11
History of the South Stoa Excavations	
Previous Scholarship on the South Stoa	
Discussion of Broneer's Reconstruction	
Part II: Documentation and Reconstruction of the Building	
Chapter 1: Materials and Techniques of Construction	36
Wood	
Metal	
Cross Wall Bonding	
Tools and Techniques of Carving	
Stucco	
Lifting and Setting Devices	
Setting Lines	
Clamps and Dowels	
Chapter 2: Foundations	50
Euthynteria Course of North Foundations	
Interior Column Foundations	
East and West End Foundations	
Foundations of Backrooms	
Euthynteria Course of Backrooms	
Backroom Dimensions at Foundation Level	
“Masons' Marks”	
Chapter 3: Krepidoma	69
Stylobate of Front Colonnade	
Toichobate	
Chapter 4: Exterior Doric Columns	85
Shafts	

Capitals	
Chapter 5: Interior Ionic Columns	118
Shafts and Bases	
Capitals	
Chapter 6: Orthostates and Wall Blocks	141
Wall Antae	
Prostyle Colonnade	
Chapter 7: Entablature	148
Architraves	
Frieze	
Exterior Doric Geison	
Geison without Mutules	
Chapter 8: Pediments	181
Chapter 9: Backrooms	183
Front Wall of the Backrooms	
Doorways	
Lower Floor Level	
Upper Floor Level	
Upper Floor Layout	
Chapter 10: Colonnade Staircase and Balcony	196
Piers and Parapet Slabs	
Pier Columns	
Chapter 11: Upper Ceilings and Rafters	209
Tie Beams	
Chapter 12: Roof	221
Horizontal Sima	
Raking Sima	
Pan Tiles	
Cover Tiles	
Sima Cover Tiles and Antefixes	
Ridge Cover Tiles and Saddle Tiles	
Chapter 13: Moldings	236
Soffit of the Lateral and Horizontal Geison	

Doric Geison Drip	
Doric Geison Crowning Molding	
Sima Moldings	
Chapter 14: Polychromy	245
Chapter 15: Refinements	247
Chapter 16: Well System	254
Part III: Design	
Chapter 17: Proportions and Metrology	262
Unit of Measurement	
Design Considerations	
Modular Proportions	
Frieze and Intercolumniation	
Column Spacing and Doric Proportions	
Design of the Backrooms	
Part IV Chronology and Function	
Chapter 18: Date and Function	286
Function of Backrooms	
Function of Wells	
Other Possible Functions for the Building	
Part V: Building Types and Precedents	
Chapter 19: Influences on the South Stoa	304
Multi-Level Stoas	
Precedents: Superimposed Storeys	
Stoa Size	
Macedonian Connections	
Appendix I: Vitruvius and Building Types	327

Illustrations

Fig. 1. Buildings underlying the stoa and stoa terrace (Williams 1972, Fig. 5).	20
Fig. 2. Broneer's section at east end showing reconstruction with staircase inside the first room (Broneer 1954, pl. XI).	22
Fig. 3. State plan view of Room I showing interior foundations for staircase. After Broneer 1954, Plan I.	24
Fig. 4. Plan of rooms XXXII and XXXIII showing offset doorways, the staircase and well with possible passageway between rooms. Note the cramped nature of room XXXIII if restored with stairs and well.	27
Fig. 5. (a) section, (b) upper and (c) lower floor plan of South Stoa, showing corridor of the upper level moved to the front (Coulton 1976 Fig. 13).	30
Fig. 6. Orthostate in west wall with cuttings for stairs. View from east.	31
Fig. 7. Photo and drawing of step cuttings in orthostate of west wall.	32
Fig. 8. Plan: West end of South Stoa, including Rooms XXXI-XXXIII. Elevation: West wall of Stoa colonnade (Williams 1980, 128, Fig. 5). ...	33
Fig. 9. Bonding of north-south cross wall with north wall of back rooms.	39
Fig. 10. 4 th century B.C. foundations for the Temple of Apollo at Delphi. Showing bonding of blocks similar in character to the South Stoa at Corinth. E. Hansen 1991, Fig. 4.	41
Fig. 11. Vertical tool marks left by flat chisel on inside face of krepidoma, showing difference in tooling between krepidoma and euthynteria course below.	43
Fig. 12. Showing final setting of stylobate block into place. Tong cuttings, mason's marks and setting line visible on interior surface of blocks.	45
Fig. 13. Cuttings for tongs in krepidoma blocks, showing protective bosses for lifting.	46
Fig. 14. Foundations of west end. Upper four courses restored. Showing system of headers and stretchers.	50
Fig. 15. Vertical cutting in euthynteria course.	52
Fig. 16. Slot cutting in euthynteria of north foundations possibly to hold wooden piece for setting line of krepidoma. Occurs approximately midway along length of building.	53
Fig. 17. Interior column foundations, illustrating technique to lower and set blocks: (a) Lowering the block into place. (b) Final positioning.	55
Fig. 18. West wall showing step cuttings. Toichobate cut back to accommodate original stair foundations.	57
Fig. 19. State plan showing west end foundations, with cut-back for staircase.	58

Fig. 20. Isometric view showing toichobate and euthynteria courses at intersection of front wall to the back rooms and dividing cross wall within rooms.....	60
Fig. 21. Interaxial dimensions of the exterior and interior colonnade vis a vis the backrooms with dimensions as built and theoretical units based on lining up the columns with the walls of the backrooms.	61
Fig. 22. Foundations for Room I at east end of stoa. The 10 cm. addition to the width of room one aligns the toichobate with the front half of the building. Note also block size changes for the foundations of the backrooms.	63
Fig. 23. Masons marks by distribution and type. After Broneer, 1954, Fig. 5.	67
Fig. 24. Setting line on Krepidoma at east end.	70
Fig. 25. West end of North façade showing setting line for stylobate course at the end.....	71
Fig. 26. Isometric view of a proposed normal stylobate block from north façade.....	72
Fig. 27. Corner contraction shown at the west end. Amount of contraction equals 0.225 m. (1/2 the triglyph width), leaving 2.115 m. for the interaxial distance at the corner.	75
Fig. 28a. West end state plan showing overlay of stylobate with alternating block lengths. Original stylobate blocks in grey; b. overleaf, Reconstruction of west end showing stylobate and interaxial dimensions based on stylobate blocks of 1.02 m. and 1.32 m.....	76
Fig. 29. Block alignment visible inside west corner, with proposed alternating stylobate block lengths.	78
Fig. 30. West end state plan showing overlay of stylobate blocks with theoretical length of 1.169 m. Original stylobate blocks in gray.	81
Fig. 31. Perspective of interior corner of northwest end showing foundations and toichobate where it turns the corner and begins running under the west wall.	82
Fig. 32. Toichobate bonding of Room I, east end.	83
Fig. 33. Perspective view of Doric column drum Northwest corner.	85
Fig. 34. Column height based on averaging column drum positions.....	94
Fig. 35. Column height based on wall height of room front wall and slope of roof as known factors.....	97
Fig. 36. Hypothetical reconstruction of column height based solely on height of wall blocks being 0.53 m.....	98
Fig. 37. Construction of flutes according to Broneer, using the tri-centric arc method (Broneer 1954, 31, Fig. 8).....	101
Fig. 38. Theoretical reconstruction of flute profile as intended with the construction of an ellipse. In the middle, the black line is the profile as reconstructed previously using three arcs. The red line is the ellipse. The ellipse would be created using a cord equal in length to the two long sides of triangles with sides 1 : $\sqrt{3}$: 2. Following method as outlined by Zambas (2002, 230-232).	102
Fig. 39. Sections of flute profiles from 1) Toward top of bottom drum. 2) Middle of second drum at west end. 3) Middle of top drum.	103
Fig. 40. Bottom drum flute section restored with ellipse profile.	103

Fig. 41. Column entasis magnified by reduction of the vertical scale 1:10. Showing maximum deflection of column taper. Column heights based on averages.....	105
Fig. 42. Hypothetical drawing showing the tilt problem incurred by the columns on a stylobate with curvature (curvature exaggerated).	106
Fig. 43. Theoretical adjustment in lowest drum to correct tilt effect of horizontal stylobate curvature on column.	107
Fig. 44. Doric capital from north façade.	109
Fig. 45. A preserved Doric capital illustrated in Broneer's publication (1954, Fig. 8).	110
Fig. 46. Doric capital elevation. Bottom and top views.....	111
Fig. 47. Restored profile of the Doric capitals from the north colonnade.....	112
Fig. 48. A selection of 4 th century BC Doric capital profiles in the Peloponnesos.	113
Fig. 49. South Stoa capital compared with Vitruvius' rules for design.....	117
Fig. 50. Reconstruction of Greek Ionic column base of interior colonnade. After Broneer (1954, 47, Fig. 25).	118
Fig. 51. Ionic column base from the Greek period of the stoa.....	119
Fig. 52. Interior flute profile bottom of Ionic column (after Broneer 1954, Fig. 25).	120
Fig. 53. Portico of Cotys at Epidauros. Ionic base profiles.....	121
Fig. 54. Ionic capital fragment. Two views showing abacus and volute.	125
Fig. 55. Ionic capital fragment. Bolster and neck from below.	126
Fig. 56. Interior Ionic capital (after Broneer 1954, Figs. 22 and 23).	127
Fig. 57. Restored plan view of Ionic capital (Broneer 1954, Fig. 24).	128
Fig. 58. Perspective model of a Greek Ionic capital from the interior of the South Stoa (Rhino model by G. Herdt).	128
Fig. 59. Ionic capital from the House of Dionysos, Pella (Makaronas 1989, Pl. 11).	131
Fig. 60. Type I and II forms of Ionic capitals from Oropos (Coulton 1968, 162, Fig. 11).	132
Fig. 61. Analysis of the volutes of the Ionic capitals from the interior. The arcs used to reconstruct the volute and the centers found are derived from ten circles which are not justified by physical evidence, nor do they represent the way the volutes were originally created, but are the way the volute was reconstructed in Autocad.....	133
Fig. 62. Hypothetical reconstruction of Ionic column. Column diameter to height ratio of 1:7.5.	137
Fig. 63. Proportional analysis of the interior Greek Ionic columns compared with the exterior Doric columns. 1. Greek phase according to Broneer. 2. Greek phase with new column heights 3. Roman phase.	138
Fig. 64. Elevation of west end showing principal dimensions affecting the anta. Hypothetical restoration with frieze turning the corner and ending over anta.....	145
Fig. 65. Isometric view of anta condition showing transition from corner column to wall.	146
Fig. 66. Section showing principal dimensions of the Doric order of the façade.	148
Fig. 67. Joining fragments of architrave (Broneer 1954, Fig. 10).	149
Fig. 68. Isometric of architrave of the north façade with backer restored.....	151

Fig. 69 Perspective showing architraves meeting at the corner and returning to back edge of anta.	153
Fig. 70. Two separate fragments of Doric frieze. At top, view of front with missing triglyph. Bottom right, back view with taenia and rebate, shown in detail at left (Broneer 1954, Fig. 12).	155
Figure 71. Frieze block shown in Fig. 70 at top.....	155
Fig. 72. Doric frieze block of the façade with principal dimensions, restored.	156
Fig. 73. Restored perspective view of frieze block.	156
Fig. 74. Restored perspective of back of frieze block, showing rabbet along upper edge for wooden molding strip.....	158
Fig. 75. a) If the frieze is cantilevered as Broneer suggested. b) More probable scheme with frieze blocks offset above the architrave.	160
Fig. 76. Hypothetical reconstruction showing insertion of a block with two metopes and a triglyph in the middle of the north frieze after setting the normal frieze blocks starting from both ends.	162
Fig. 77 Perspective showing a proposed solution for frieze blocks at the N.W. Corner.....	163
Fig. 78. Frieze block state drawing (Broneer 1954, Fig. 17).	165
Fig. 79. Hypothetical reconstruction of position of frieze block at west end of stoa.	166
Fig. 80. Perspective of frieze block at termination of back edge of anta on west flank, abutting normal frieze on corner.	166
Fig. 81. Perspective of entablature with cutting on upper surface of frieze, showing dowel cutting for position of rafters and spacing of beams if without tie-beams. In this scheme rafters are ca. 0.46 m. in height.	168
Fig. 82. Perspective of alternative rafter system, showing dowel cutting for position of hypothetical horizontal tie member and spacing of beams. .	168
Fig. 83. Horizontal geison block from North entablature (after Broneer 1954, Fig. 14).	170
Fig. 84. Position of geison block in restored entablature.....	171
Fig. 85. Corner geison block state drawings and restored position at N.E. corner of building (Broneer 1954, Fig. 15).	172
Fig. 86. Restored perspective view showing setting line and resting surface for the raking geison and front pediment slope.	174
Fig. 87. Corner geison reconstructed, with beginning of raking geison, showing problem of the sloping front surface for the front lip of the raking geison.	174
Fig. 88. Cornice without mutules (Broneer 1954, Fig. 33).	175
Fig. 89. Back of stoa showing possible position of cornice string course.	177
Fig. 90. Hypothetical reconstruction of geison above interior colonnade.	178
Fig. 91. Hypothetical reconstruction of geison without mutules used for the continuation of the horizontal geison on the side walls.	180
Fig. 92. Propylaia at Athens. Condition at N.E. corner of central building where Doric frieze and cornice stops on side wall (Tanoulas 1997, Fig. 4).	180
Fig. 93. Reconstructed corner geison showing slope of raking geison indicated in red according to new measurements.	182
Fig. 94. Reconstruction of pediment showing possible scheme for blocks. .	182

Fig. 95. Back rooms of stoa at west end. At both ends of the building the last room extends to the full depth of the building, while the rest of the rooms stop before this depth. Note the wells, which are not centered in the rooms with any degree of consistency.	183
Fig. 96. First doorway at east end showing east jamb in situ and cuttings for the doors (Broneer 1954, Fig. 26. See Broneer <i>ibid.</i> p. 48, 49, for discussion of its finding).	185
Fig. 97. Doorway wall block from second course, east side (Broneer 1954, Fig. 27). This block was found in the Cryptoporticus of the South Basilica (see Broneer <i>ibid.</i> p. 50 for its finding).	186
Fig. 98. Doorway wall block from top of wall with hawksbeak molding partially preserved (Broneer 1954, Fig. 29).	186
Fig. 99. Two lintel block fragments and four short blocks belonging to the doorways (Broneer 1954, Fig. 28). The short blocks have dowel cuttings to hold the wooden door frame. The lintel is surmounted by a hawksbeak, restored in the drawing.	187
Fig. 100. Doorway in front wall of back rooms reconstructed with principal dimensions.	188
Fig. 101. Perspective showing back of lintel from inside room with hypothetical position of beams for ceiling.	189
Fig. 102. Necessary components of upper floor following Vitruvius.	192
Fig. 103. Perspective reconstruction of the North stoa on the Agora at Assos. Note the thickness of the upper floor, which is evidenced by the rough finish of the backs of the cornice and upper stylobate on which the parapet rests. Note also the thickness of the ceiling beams, evidenced by the back wall construction (Clarke, et al. 1902-21, 45).	194
Fig. 104. Reconstruction of staircase against west wall.	197
Fig. 105. Plan of upper floor level, showing hypothetical balcony layout.	198
Fig. 106. Elevation of staircase against west wall.	200
Figure 107. Preserved sections of piers and parapet slabs.	202
Fig. 108. Pier and parapet slab as restored.	203
Fig. 109. Fence posts for the Eponymous Heroes monument in Athens (W. B. Dinsmoor 1968).	204
Fig. 110. a. Pier column as preserved; b. as restored with parapet slabs.	205
Fig. 111. Example of small pier capital (Broneer 1954, 78, Fig. 55.)	206
Fig. 112 Upper storey balcony showing possible position and reconstruction of parapet fragments with the reconstruction of pier columns.	207
Fig. 113. Block with sloping taenia (Broneer 1954, Fig. 60).	210
Fig. 114. Reconstruction showing block with sloping taenia, rafters and ceiling boards fitted into slot on block.	210
Fig. 115. Position of block with sloping taenia (in grey) in pediment; showing how the block would work with rafters and battens running back down to the front wall of the backrooms. The block fits precisely into the hypothetical rhythm of the pediment blocks.	211
Fig. 116. Reconstruction using block with slanting taenia for lower roof according to Broneer (1954, 82). Showing problem of having to seal joint between tile and wall block.	213
Fig. 117. Corner block with sloping taenia (Broneer 1954, Fig. 21).	215
Fig. 118. Isometric of the corner block with sloping taenia restored to position at Southwest corner of Room 1. The corner block is in grey. The	

hypothetical block above would be sloped on top for the rafters to sit and continue the taenia.	215
Fig. 119. Perspective showing roofing system proposed by Broneer (Drawing by Piet de Jong, illus. frontispiece to Broneer 1954).	217
Fig. 120. Perspective of entablature with hypothetical restoration of horizontal tie-beams. Dowel on top of the frieze toward front is for the geison.	220
Fig. 121. Horizontal sima and antefixes.	222
Fig. 122. Section of the raking sima.	224
Fig. 123. Corner sima from a Hellenistic building at Corinth showing transition from plastic decoration to painted decoration (De Waele 1931, Fig. 10).	225
Fig. 124. Restored pan tile of the South Stoa.	226
Fig. 125. Hypothetical reconstruction of half-tiles with upturned edge along the inner raking edge of the roof for the two projecting wings at the back of the stoa.	228
Fig. 126. Perspective of original cover tile, showing dimensions	229
Fig. 127. Perspective showing roof tile system	230
Fig. 128. Terracotta roof tile with projecting ears.	231
Fig. 129. Perspective view of sima cover tile with antefix.	232
Fig. 130 Antefix attached to lateral sima cover tile.	232
Fig. 131. Perspective view of ridge cover tile with dimensions.	234
Fig. 132. Profile of triple banded drafting of krepidoma and toichobate blocks.	236
Fig. 133. Geison soffit Moldings comparison. a. Temple of Apollo, Delphi; b. Temple of Athena, Delphi; c. Thersilion, Megalopolis (raking); d. Temple of Athena Alea, Tegea; e Temple of Zeus, Nemea; f. L-shaped stoa at Perachora; g. South Stoa, Corinth (raking); h. South Stoa Corinth (horizontal).	237
Fig. 134. Doric geison drip. a. Temple of Zeus, Nemea. b. Temple, Stratos. c. South Stoa, Corinth. d. Choregic monument of Nicias, Athens. e. Asklepieion, Corinth, 2 nd half 4 th c. f. Stoa at Perachora.	239
Fig. 135. Comparison of Doric Hawksbeak. a. South Stoa, Olympia. b. Temple of Apollo, Delphi (4 th -century). c. South Stoa, Corinth (horizontal). d. South Stoa, Corinth (raking). e. Thersilion, Megalopolis. f. Asklepieion, Corinth. g. Stoa, Perachora.	241
Fig. 136. Elevation showing the profile of the lateral sima of the North façade.	243
Fig. 137. Raking simas, Corinth: a) South Stoa; b) Asklepieion; c) area of Temple Hill.	244
Fig. 138. Sima with lion head waterspout.	246
Fig. 139. Stylobate curvature as reconstructed, with three possible solutions for the curve represented. Datum point at both ends is assumed for this analysis to be at the same level.	248
Figure 140. Illustration of Parabolic curve established with horizontal coordinates multiplied. (Stevens 1934, 537, Fig. 4).	252
Fig. 143. Wells of the South Stoa with water channel from Peirene Fountain.	256
Fig. 144. Section showing Peirene tunnel and well shaft inside back room of stoa.	257

Fig. 145. West end showing underground water channel, well construction and lines of site for establishing the channel.	259
Fig. 146. Principal dimensions of the Doric Order of the façade.	270
Fig. 147. Romano's stadion length applied to the colonnade of the South Stoa.	272
Fig. 148. Rooms shown with addition of dining couches of standard size (0.82 X 1.80).	295
Fig. 149. Rooms with addition of dining couches using a modified length of 1.98 m. for couches	296
Fig. 150. South stoa I details and elevation as restored by Dinsmoor, Jr. (Thompson 1968, Fig. 2).....	307
Fig. 151. South stoa I, restored perspective. View from southwest. As restored by Dinsmoor, Jr. (Thompson 1968, Fig. 3).....	307
Fig. 152. View looking west inside the colonnade of the Stoa at Brauron (Orlandos 1961, Fig. 21).....	309
Fig. 153. E.W. section through the Asklepieion and Lerna at Corinth, showing central complex on two levels (Roebuck 1951).....	309
Fig. 154. Epidauros, Abaton Extension, section and elevation (Coulton 1976, Fig. 10).	310
Fig. 155. Pastas-type interior courtyard showing two-storey arrangement with balcony (Hoepfner 1999).	312
Fig. 156. The Dema House (Jones 1962).	314
Fig. 157. West wing of the Stoa by the Harbor, Miletos. Reconstruction by Coulton (1976, Fig. 37).	316

Acknowledgements

This study of the South Stoa was made possible with generous support from the 1984 Foundation. I would like to thank the Director of the Corinth Excavations, Guy Sanders, for permission to undertake this study and the staff of the Corinth Excavations, Ioulia Tzonou-Herbst and James Herbst for helping facilitate my research there. I would like to thank my advisor, Mark Wilson Jones, in the department of Architecture at the University of Bath, for his support and encouragement at all steps along the way. It was his work on Greek and Roman design issues which inspired me to delve into Greek design in stoas as I did. The need for a new study of the South Stoa at Corinth was first suggested to me by C. K. Williams II, Director Emeritus of the Corinth Excavations, to whom I can only extend my deepest gratitude in return for support and encouragement of my research. His own earlier work on the building and his willingness to share his knowledge on site helped me enormously. I also wish to thank John Camp, Director of the Athenian Agora Excavations, for unflagging support and wise council over the years that I spent as a trench supervisor at the Athenian Agora and my time there as an assistant architect. My research was carried out in Greece at and under the auspices of the American School of Classical Studies at Athens. I thank especially Director Jack Davis, former Director Stephen Tracy and Administrator, Maria Pilali, for their support. Among the ASCSA community, during my Regular Year and afterwards, I have benefited from the collegiality of a number of people, only a few of whom I can single out here: Richard Anderson, Judith Binder, Nancy Bookidis, Michael Djourjevitch, Brice Erickson, Georg Herdt, Yannis Lolos, Margie Miles, John Oakley, Lee Ann Riccardi, Molly Richardson, Peter Schultz and Jim Sickinger. They and others have all in one way or another helped me get to this point. I thank Paul Richens for valuable comments and criticism, especially concerning mathematical issues. Christopher Pfaff has helped guide my thinking about Greek architecture as it has developed. Jason Harris saved me from editorial mistakes. My

undergraduate advisors, Robert F. Sutton Jr. and Susan Sutton, sparked my initial interest in ancient and modern Greek culture and for that I am forever grateful.

Among the community in Athens, I would like to especially acknowledge two architects, Manolis Korres, whose time I have taken up on many occasions at the Polytechnic University and with whom I have enjoyed εκδρομές in the Greek countryside to learn about architecture and fish tavernas; and Tasos Tanoulas, who, besides offering me valuable advice, friendship and true φιλοξενία, allowed me to participate in the Propylaia Restoration Project, climb the scaffolding to inspect blocks and learn from the masons how to carve Pentelic marble as an apprentice of sorts. Finally, I dedicate this work to my parents, who have always given me unconditional support and encouragement to follow my interests wherever they might lead and to my wife, Maraia, and daughter, Ellie, who both inspire me beyond words.

Abstract

The focus of this dissertation is the design, construction and function of the South Stoa at Corinth in its initial phase. The South Stoa was first published in a monograph by Oscar Broneer in 1954.¹ In addition to dealing with the Greek and Roman phases of the building, Broneer's study also dealt with the "pre-stoa" remains. Certain aspects of the architecture of the stoa, however, were either treated only briefly or were entirely left out of the publication. While it was one of the first attempts at a full study of a secular Greek building, several conclusions deserve re-evaluation, including the date of construction and the design of the building in its initial phase, which has an impact on subsequent phases of remodeling, the function of the building, as well as its place in the historical development of stoas.

Re-evaluation of the in situ remains of the stoa combined with newly identified architectural fragments of the building, particularly from the superstructure, provide important evidence to suggest an alternative reconstruction to that previously put forward. This new reconstruction is presented as the most likely solution, in awareness of the possibility that future finds may give rise to modification. As will be shown, the staircases inside the first and last front rooms of the stoa do not belong to the initial building phase as previously thought, but instead date to the Roman period, while evidence in the form of foundations and cuttings for a staircase inside the colonnade at the west end of the stoa, dated prior to 146 B.C., belongs to

¹Broneer 1954.

the initial phase of the building and calls for an entirely different interior reconstruction.

The date of the stoa, which has fluctuated from sometime after the middle of the fourth century B.C. (340-320 B.C.) to the early decades of the third century B.C., can now be more precisely determined in view of recent examination of pottery deposits from beneath the stoa terrace, which was built prior to the stoa's construction. These deposits have been dated between 300-290 B.C., which would push the date of the stoa's construction to the beginning decades of the third century B.C. This has considerable bearing on the early development of Hellenistic stoas and on the stylistic chronology of several other buildings built around the end of the fourth century B.C.

Having resolved aspects of the reconstruction and situated the stoa chronologically, the focus of this study moves on to design considerations, including examination of the proportions and of the ancient foot unit used in the design of the building. Construction and statics of the building are also considered.

Methodology

The study of Greek architecture as a discipline within the field of archaeology has recently been criticized by Robin Osborne for the lack of any new comprehensive treatments to speak of. Regarding recent work on architecture in archaeology he states,

The absence of standard or exemplary architectural analyses that delve into every aspect of the building, including the moldings, seriously hampers teaching the subject (it is currently effectively impossible to teach Greek theatre architecture at all).²

While this assessment might be exaggerated, as there are quite a few recent exemplary architectural analyses that do comprehensively treat buildings, Osborne has a point with respect to the number of buildings which have been uncovered in excavation and the number that have been published fully. Those studies that are made often take many years to produce due in part to the enormity of the task at hand.³ In fact, one might ask if it is not better to have a team rather than one researcher working on individual structures. In any case, this is one reason for the lack of published studies. Another reason is that the discipline as a whole lacks a coherent program to educate students in analysis of ancient architecture. Training in archaeology and art history does not lend itself to studying aspects of architecture such as design and structure, which are a field in and of themselves. Architects, on the other hand, are not usually trained to deal with the archaeological and historical implications associated with buildings. A middle ground was the German

² Osborne 2004, 96.

³ See for example Bankel 1993 on the late archaic Temple of Aphaia on Aegina; Pfaff, 2001, on the Classical temple at the Argive Heraion 2001; or more recently Hansen 2010, on the fourth century temple of Apollo at Delphi, to name just a few.

system of Bauforschung or Baugeschichte, which trained architects in field archaeology.⁴ This system is now all but defunct, and it was not emulated anywhere else as a way to train students of architecture within archaeology. One notable exception is in Greece, where a few architecture students are trained to deal with ancient architecture, largely in a kind of apprenticeship system, deriving ultimately from training on Greek monuments undergoing reconstruction and conservation under the auspices of the Greek Ministry of Culture. In any event, there are still those who manage to attain sufficient training in both fields, but it seems doubtful that in the near or medium future we will see the plethora of researchers that one sees working with other aspects of material culture.

Despite these problems, there is still research and lively debate in the field. Of these debates, a major one concerns the design process, but reconstructing the design process and the final resulting building or structure prove difficult in even the best cases where the material evidence is relatively well preserved. Speaking about Greek temple design, the study of which has received more coverage than any architectural form from ancient Greece, Mark Wilson Jones states:

“Not only was [the Doric temple] the ultimate reference for other typologies (propylaea, stoas and miscellaneous civic buildings), it was also, especially in its fifth-century form, a highly influential source for the later practice of Classical architecture. Yet, the methods used to design the ancient Doric temple remain a largely unresolved question despite the considerable scholarly effort dedicated to its investigation.”⁵

⁴ The peak period of this system in the twentieth century was under the leadership of Gottfried Gruben in Munich in the 1960s and 70s.

⁵Wilson Jones 2001, 675.

For the majority of stoas in the Classical and Hellenistic periods the material is usually not very well preserved, nor as intensively studied. Reconstructions rely on comparison to known examples, when possible, where pieces of the puzzle are missing. Another guide is the architectural order used. While this can be helpful, each building does something different or new, defying the rigidity of the order and the false security that parallels can provide. Proportional relationships may help in the case of plan and elevation, but here too, any canonical relationships are undermined by experimentation and developments in each particular case. For interpreting the design of stoas and other buildings one of the biggest problems concerns measurements and their interpretation. Almost every study of the Parthenon, for example, offers a different set of measurements and a different interpretation of the data. This would be perhaps more tolerable if the results of a given study were not often reliant on milli-metric precision for issues such as design intentions or modifications and proportional relationships.⁶

The methodological approach employed in this dissertation seeks to position the South Stoa within the wider scope of design practice in Greek architecture. There are generally three ways in which architectural studies can be, or have been, approached. There is the monograph on a single building, which largely treats a building in isolation, preferring to describe the remains and posit hypothetical reconstructions based on parallels or comparisons when necessary for certain details. An inevitable shortcoming that occurs with this or any other method is missing data or lack of parallels. On the positive

⁶An especially good example is the recently published study of the Propylaia (Dinsmoor 2004), which presents a hypothetical design process dependent on converting modern measurements of millimeters into Doric feet.

side, it allows for a thorough and detailed description of the remains. Then there are comparative or diachronic studies which gather many buildings together for the purpose of finding trends or characteristics in design and function. On a general level, this sort of synthesis of the evidence can be useful. A criticism of this method is that almost all of the buildings surveyed are missing vital data, or the data they provide may have been misinterpreted in previous analysis and this kind of study inherently takes for granted that the data can be trusted. A third approach would be to take one building and, after describing it in detail, position it within its regional context and the overall scope of Greek architecture with which the building is contemporary. Keeping in mind the shortcomings of comparative material, this approach is more sympathetic to trends across building types, which arguably better reflects the reality of the actual practice of designing and constructing ancient Greek buildings.

The advantages of doing a study this third way are significant. It provides an avenue for discussion of previous hypotheses with respect to the building under study, for new hypotheses to be put forward within the overall context of Greek architecture, and for greater transparency regarding the interpretation of the evidence since the building can be covered in more detail. And perhaps most importantly it forces us out of the all too comfortable idea that Greek architecture must fit a pre-defined pattern of design and construction. The shortcomings of this kind of treatment will become apparent to the reader in the following analysis of the South Stoa. When parallels are not forthcoming, recourse to other types of buildings only sometimes provides an answer. When it does not, the hypothetical reconstruction that is posited is

supported or weakened depending upon the level of probability. This, however, brings the discussion back to the beginning, as probability in Greek architecture is a slippery slope given the nature of design possibilities. Given that the focus has been on temple design at the expense of other building types, stoa design was for the most part of marginal concern to archaeologists and historians of architecture.

The study of stoas began to increase, however, in the 1960s. Previously, stoas usually received only cursory treatment in the form of preliminary or excavation reports, and, at most, were included marginally in wider, general works on Greek architecture. This changed dramatically with the publication in 1976 of Coulton's book, in which he discussed the development of stoas from the context of known examples. Coulton's study included a catalog of the stoas known up to that time, making clear how ubiquitous stoas were in city-states throughout the Greek world. It also brought to light the fact that most lack full documentation.⁷ The present study is intended in part to add to our knowledge concerning stoa design and construction, particularly at the point in the late fourth and early third centuries B.C. when monumental stoas begin to flourish and attain a larger presence within the fabric of Greek city-states, foreshadowing later Hellenistic building activity. The study also examines the wider importance of the South Stoa at

⁷Overall, only a handful of stoas have received the kind of attention that temples have. Besides the South Stoa at Corinth, the stoas in the agora at Thasos were dealt with in depth by Martin (1958). See Coulton (1964; 1967) on the Stoa at Perachora and the Amphiaraion at Oropos (1968) and his book *The Architectural Development of the Greek Stoa* (1976). See also Bouras' 1967 study of the Stoa at Brauron. Otherwise, information must be gleaned from preliminary reports, or very early publications, most of which are from the early twentieth century. The study of the Agora Stoas at Assos by Clarke, Bacon and Koldewey published in 1902 is an example of an excellent study for its time. Also see Seddon 1987, for an in depth analysis of Attalid connections with stoas in Asia Minor.

Corinth within the development of the stoa as a building type and its relationship with other forms of architecture, especially monumental civic buildings.

Late Classical and Hellenistic stoas reveal a standardized process of construction in terms of modular design, arguably even more rigidly so than temple architecture, where sculptural programs influence design considerations, in some cases to a high degree.⁸ Stoas constructed in the Doric order differ from temples in not having to deal with corner contraction, except in the few cases of stoas that have a prostyle arrangement for the colonnade, as in the South Stoa at Corinth. At the same time, stoas maintain a degree of tolerance and experimentation in form, not least of which is due to function, and flexibility of form is inherent from the beginning. The development of stoas with two or more levels also requires a different set of rules in terms of proportion and design. Although borrowing stylistically from temple architecture, Greek stoas had to accommodate a variety of public functions, which would have influenced the overall design perhaps more than the formal elements would. How this plays out in stoa architecture is somewhat elusive. Is it possible to see design issues influenced by what was needed in terms of the function or various functions of a given building, and did this in turn contribute to the overall development of design in Greek architecture? Formal qualities like proportion and scale, or technical problems such as the use of the Doric frieze when there is a re-entrant angle are obvious examples of the types of design issues which would be affected by

⁸ For example, the Parthenon (see especially Korres 1994, 95, Fn. 29), in which the planning of the architectural design must have taken place with the sculptural program in mind.

the form that the building took to accommodate different activities.⁹ The whole issue cuts across the dividing lines of building types. As J.J. Coulton puts it,

“Sometimes the transition from temple to secular building was effortless, but more often the requirements of the new situation made some sort of adjustment necessary, and this process of transference stimulated many of the formal innovations of later Greek architecture.”¹⁰

To add to Coulton’s remark, it is not just secular buildings that form a new or different horizon distinct from temple construction, as stoas could serve a religious and/or secular function.

The wider significance of this study is its contribution to a more nuanced understanding of Greek building practice in antiquity, whereby sacred and secular Greek monumental architecture can be seen as intrinsically bound, influencing one another within a building tradition that was relatively consistent in terms of design principles, but flexible in application.

While the main focus of this dissertation is the initial phase of the South Stoa, an attempt has been made to look diachronically at the building as a monument with a long history, from the early third century B.C. to the 6th century A.D., although a full study of the later phases represents a separate enterprise. Only after the initial phase is reconsidered, can a detailed study be made of the extensive alterations that took place during the Roman period up to the final destruction of the building in the Late Antique period.

⁹ See Coulton 1966, 132-146.

¹⁰ See Coulton 1977, 125ff.

Over a half a century has elapsed since the initial publication of the South Stoa at Corinth. The time seemed right for a re-evaluation of the building. Any contributions presented here to furthering its understanding are due in large part to the accumulation of developments in scholarship on ancient Greek architecture that has been amassed in the intervening years.

What follows is an attempt to unravel design issues affecting the South Stoa that have been problematic since the initial excavation and publication of the building and then to reassemble it from the ground up, positioning it within its wider context architecturally and historically.

INTRODUCTION

Stoas could serve a number of different functions. J. J. Coulton has compiled an extensive list of uses to which stoas were put, but it is useful to summarize the evidence.¹¹ First and foremost the colonnade, itself, served as a promenade and provided shelter in the most basic sense. Stoas were constructed in both sanctuaries and civic spaces and their purpose essentially crossed all lines of human activity whether religious or secular. Stoas in sanctuaries could serve a number of practical functions related to religious activity, or they could be a repository for votives. For instance, the Stoa Basileos in the Athenian Agora served a dual religious and political function and points to the fact that stoas in public spaces could still serve a religious function. Aside from their use in sanctuaries, or other religious contexts, stoas could, among other things, be constructed to have a commercial, political, or some other public function; or they could also combine these functions. Another function that stoas served is associated with facilities for athletic training, as witnessed by stoas attached to Gymnasium complexes, such as at Olympia. A particular kind of stoa attached to gymnasia functioned as a covered running track (*Xystos*) the best preserved being the long stoa at Delphi. For most stoas, however, there is a lack of evidence for definite activities that took place within them and our knowledge of their function relies heavily on literary testimony. Generally it is assumed that function was tied to

¹¹ See Coulton 1976, 8-12, for a summary of different uses attested by ancient literary testimony, since no stoa, to my knowledge, has been ascribed a function based solely on archaeological evidence with the exception of *xystoi* that have starting lines (see below).

public utility of some kind and the stoa form was adaptable to a multitude of purposes.

All of the functions described above must be taken into account when considering the motivating factors that went into their construction, but there are other factors as well. Stoas could be built as a result of internal forces, such as in the case of a city raising the funds and constructing a building for a particular purpose, or external forces, such as when an outside benefactor pays for construction. The latter case is certainly seen in the Hellenistic period tied to dynastic interests, a good example being the stoas of Attalos and Eumenes in Athens. We cannot, however, rule out the possibility of a stoa being built by a combination of internal and external forces, such as if a city wanted to curry favor by dedicating a stoa in honor of a ruler and an external donation could match a need already identified.¹² Once the monetary investment was initiated the next step would be gathering the manpower required for construction. The infrastructure for a large building project such as the South Stoa at Corinth would not be a small thing. Quarrying and transport of the stone, digging out and laying the foundations, sizing and cutting the individual blocks, carving the details, producing the terracotta roof tiles, transporting, cutting and installing the timber for the roofing and floors, would all have required different significant levels of expense and manpower.

When it was constructed at the end of the fourth century B.C., the South Stoa at Corinth was one of the largest to be built and among the longest known examples to date, measuring just over 164 m. in length on its

¹² Such as may be the case for the stoa of Philip in Megalopolis, according to Pausanias 8.30.6. Another stoa in the same city testifies to buildings paid for by private individuals, in this case a certain local man named Aristander (Paus. 8.30.10).

stylobate and slightly over 25 m. in width from front to back on the stylobate.¹³

Plate 1 It defined the south side of the open area to the south of Temple Hill and in the Roman period dominated the south side of the Forum in its renovated configuration. The orientation of the stoa is nearly identical to that of the Archaic temple on Temple Hill and only slightly different from the orientation of the race course, or *dromos*, that extended across the open area just in front of the stoa. **Plate 2**

The building consisted of a single storied façade with 71 Doric columns. In the interior there were 34 Ionic columns in the lower storey that most likely carried a balcony with piers forming a parapet. At the back of the stoa was a series of 33 rooms, each with a rear compartment and rooms above on an upper storey. Apparently after the initial construction, each of the rooms, with the exception of the first and last, was given a service unit at the back.¹⁴ Each of the front rooms, with the exception of the first and thirty-second rooms, was also given a well, connected by an underground water channel to the extensive Peirene water system. In the early Roman period the building underwent a major refurbishment, altering the original layout of the backrooms and replacing the earlier columns of the interior colonnade. The alterations to the back rooms took place over an extended period of time. The colonnade and rooms of the stoa continued in use in some form into the Late

¹³ The overall length on the stylobate/toichobate is 164.38 m. (+/- 0.01 m). The axis of orientation of the stoa is 20 degrees east of North. The stoa at Kameiros, dated sometime in the Hellenistic period had a length of 207 m. and depth of 15 m. (Jacopi 1933, 241-9). The East Building in the South Market at Miletos, dated to the first quarter of the 3rd c. B.C., was 189 m. long (Knackfuss 1924, 31-47). See below for more discussion of these buildings.

¹⁴ For the date of the construction of the service units, see Williams 1980, 116. Also, Broneer 1954, 67-68.

Antique period before finally being destroyed and plundered for building material sometime after the sixth century A.D.¹⁵

For the South Stoa, a large, relatively flat area was set aside next to the Classical racecourse, making the stoa a southern boundary for the open area to the south of Temple Hill. Therefore, the site for the South Stoa appears to have been chosen partly as a means to enclose this space. The stoa would have provided a good vantage point from which to view the race course and any other activities taking place there. Before the stoa was constructed there were several buildings of differing character occupying the area.¹⁶ These were described by Oscar Broneer as being public buildings; including a shrine, a “tavern”, and also what was taken to be a complex of houses, all of which he thought might have some bearing on the location of the early Agora.¹⁷ **Plate 3 and 4** The preceding buildings received further attention in the early 1970’s when sections of four structures were excavated by Williams, who described them in preliminary reports.¹⁸ A full description of the area prior to the construction of the stoa is outside the scope of this dissertation, but these structures come into play in the discussion concerning the date of the South Stoa. What is important to note is that this area, with its temple, shrines and racecourse, plus an ample supply of water, had already been given over to public building in Classical times. The relationship of the South Stoa to other building activity in the surrounding area is relevant to an

¹⁵ Broneer 1954, 154. This refurbishment, which fundamentally altered the back rooms and roofline of the building, will be dealt with separately, but the evidence for alterations to the colonnade is discussed below.

¹⁶ Some of these remains were described by Broneer 1954, 7-17. See also Williams 1980.

¹⁷ Broneer 1954, 7-12.

¹⁸ Williams 1979, 125-136; 1973, 1-44; 1972, 143-184. For earlier publication of these remains see, Morgan, 1953, 131-140; 1939, 258.

understanding of this public space as the use of space in this part of ancient Corinth prior to the Roman period is not entirely clear. Beyond the knowledge that it was public space, evidence is lacking to say for certain whether the activities taking place there were commercial or administrative in nature. While there are signs of public use in the design of the South Stoa and material brought to light from excavation of the building, which will be discussed, the function of the building, at least initially, is an open question, although the possibilities can be narrowed down as will be discussed in the concluding chapters.¹⁹

During the period that the South Stoa was constructed there appears to have been an effort to reorganize the adjacent area, although whether this was a large program or piecemeal remains uncertain. At roughly the same time, that is, the late 4th to the beginning of the 3rd century B.C., two more stoas were constructed north of the racecourse at the foot of Temple Hill and a market/stoa was built along the north edge of Temple Hill.²⁰ Shops were already in place along the west side of the Lechaian Road and possibly on the east side also.²¹ In comparison to these other buildings, the South Stoa was arguably much grander and more elaborately designed and its length covered the entire south side of the area. This alone may indicate that the building served a special function in the city, in contrast to other less sophisticated or

¹⁹ The lack of public records or other signs of public administrative buildings prior to the Roman period led Williams to suggest that the area south of Temple Hill was not the site of either the Classical or Hellenistic agora. See especially Williams 1970, 32-39.

²⁰ A good general discussion of the monuments and buildings occupying the area in the fourth and third centuries is needed. For individual monuments and their relationship to the area, see Williams, 1968, 1972, 1979, 1980 with reference to earlier publications. For the Northwest Stoa (south of Temple Hill) see Stillwell 1941, 89-130. This building is discussed in more detail below.

²¹ For description and chronology of buildings along the Lechaion Road, see Stillwell 1932, 149-157.

less monumental public buildings in the area.²² The monumentality of the South Stoa is not a sure indication of status, however. Important buildings in Greek city-states were not always the most richly appointed.²³ Certainly the monumentality of the South Stoa testifies to the expenditure of substantial funds and effort. Whether or not the city provided for its construction or whether the funds were provided by a donor is also relevant and has a bearing on possible functions for which the building might have been intended. This question will be dealt with in more detail below.

The South Stoa belongs to the beginning of the Hellenistic Age, a period that inaugurated large scale building activity throughout the Greek world in which Greek city-states embellished public spaces with extensive colonnades, many of which were stoas of some form, along streets and open areas.²⁴ In large part these buildings appear to have been financed by donors, many of whom were among the political elite seeking regional influence and control in the Greek world at this time. This is especially true following the

²²Broneer 1954, 98-99.

²³ For example, South Stoa I in the Athenian agora, arguably an important public/civic building of the later fifth century, was constructed with a modest stone socle and mudbrick walls. Compare this situation with the more richly decorated Stoa Poikile in Athens (mid 5th c. B.C). A number of important functions have been proposed for South Stoa I, among them that the building served as a public dining facility for officials (Thompson 1968).

²⁴ A colonnade, itself, was not necessarily a stoa, but every stoa had a colonnade. The colonnades on the agora at Miletos are good examples of this distinction. The South Market comprises shops fronted by a single colonnade, which is part of a larger square of colonnades (see Coulton 1976, p. 7, on the South Market and *ibid.* pp. 1-17 generally for the terminology of stoas, both ancient and modern). The lack of a definite form compounds the problem of attempting to define stoas stylistically and in terms of function. Coulton (*ibid.*) would hesitate to define the Square Market as a stoa proper, but I would argue that if the other sides of the square had not been built there would be no question that it is a stoa. This is dealt with in greater detail below in the discussion on design issues and building types.

death of Alexander. The South Stoa at Corinth may be among the first of these extensive building projects, if not the first.²⁵

Since Broneer's publication of the South Stoa, much work has been done on Greek stoas in general, and with the South Stoa in particular, previous assumptions and conclusions have been questioned as a result of ongoing investigations in the area. Broneer's reconstruction of the building was questioned by Coulton in 1976 and later by Williams in 1980. Coulton proposed a different layout for the upper floor rooms and Williams showed that a staircase belonging to the Greek phase of the building existed against the west wall inside the colonnade. The present study brings together these arguments for the first time, along with my own re-evaluation of the stoa remains, permitting a more accurate restoration of the initial phase of the building, including the height and proportions of the colonnade and the design of the upper storey, and a re-thinking of the building's function in its historical context.

Furthermore, analysis of the design details and reconstruction, combined with newly established dates for the construction of the South Stoa, allows for reconsideration of the South Stoa in the architectural tradition of the 4th century B.C. and early 3rd century B.C. in Greece.²⁶

²⁵ Broneer postulated that the building was constructed for the League initiated by Philip after Chaironea (1954, 98). As will be discussed below, the date of the building is some thirty years later, which makes this attribution untenable. The later date, however, raises the possibility that a later incarnation of the league under Demetrios Poliorketes may have initiated its construction.

²⁶ This is especially due to the fact that the moldings of the South Stoa were used as one of the benchmarks for the chronology of buildings in the fourth century B.C. (see discussion below concerning the moldings).

History of the South Stoa Excavations

The South Stoa was excavated by the American School of Classical Studies at Athens in several campaigns beginning in 1896, continuing intermittently until 1950, and then again in the 1970's. The American School acquired permission to begin excavations at Corinth in 1896 under the leadership of Rufus B. Richardson, who began exploration of the areas around the hill on which the Archaic temple stood and in the area of the theater. One trench (number VIII) at the southeast corner of the excavations should have revealed part of the back foundations of the stoa, but in the published plans of 1907, no indication of walls is shown in this trench.²⁷ Rufus Richardson, however, does clearly state in 1897 that "this trench (Trench no. VIII) revealed a great many walls most of which appear to belong to buildings of the Hellenic period."²⁸ Then, in 1904, part of the front stylobate at the west end as well as part of the front wall of the backrooms were uncovered in separate trenches, so that it was possible to know the arrangement of the colonnades and intercolumniations.²⁹ This is as far as excavation went in the area until 1933. From 1933, until interruption by the Second World War in 1940, excavations continued on the south side of the forum under the direction of O. Broneer, during which time most of the length of the building

²⁷ For the published plan showing the north end of this trench, see Corinth I, I, plate III. The trench is partly cut off by the border on the bottom right side. Broneer (1954, 3) stated that Trench VIII revealed the full width of the stoa, but this is impossible as it starts south of the front line of the building.

²⁸ Richardson 1897, 471. Because of the imprecise surveying and measuring used for the drawings in the 1897 report, it is impossible to know which walls are shown and later reports do not clarify the situation. Not only were there walls, there were also four wells and two rectangular shafts as well as a marble group with Dionysos, a nymph and Pan, among other sculptural pieces, and painted terra-cotta "trimmings" (most likely sima fragments).

²⁹ Heermance 1904, 437.

was uncovered from front to back.³⁰ Excavations resumed again under Broneer after the Second World War from 1946 until 1953. Broneer published his study of the building in 1954.³¹ During this period, from 1946 to 1947, G. R. Edwards excavated the wells inside the rooms of the stoa, publishing the pottery in his *Hellenistic Pottery* volume from Corinth in 1975.³² In the late 1960's Williams excavated and published the remains of four buildings lying under the west end of the terrace and running partly under the stylobate of the South Stoa at the west end.³³ **Fig. 1** In the early 1970's excavations were conducted by Williams at the West end of the South Stoa, concentrated on the foundations and the service units at the back of the building.³⁴ Since the early 1970's, no new information from the building remains has come to light until the present study.

³⁰ See Broneer 1954, 3-6; For preliminary reports see Broneer 1935, 53-75; Stillwell 1936, 21-45; Morgan 1936, 466-484; 1937, 539-552; 1938, 362-370; 1939, 255-267; Weinberg 1939, 592-600; Broneer 1947a, 233-247; 1947b, 271-273; 1951, 291-300.

³¹ Broneer 1954.

³² See Edwards 1975.

³³ Williams and J. Fisher 1972, especially p. 153, 170, 171. These buildings are discussed below concerning the construction date of the South Stoa.

³⁴ See Williams 1980, with reference to earlier reports.

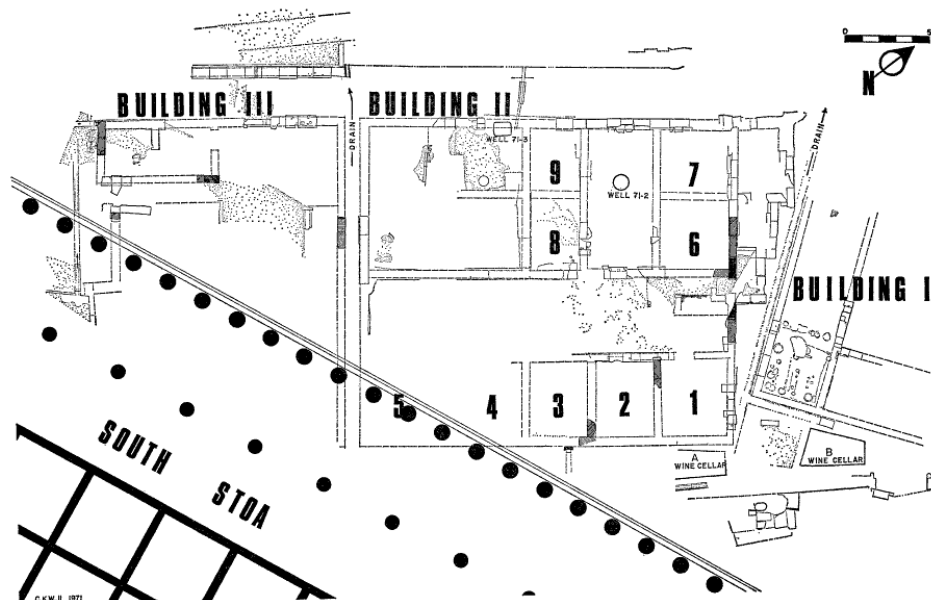

Fig. 1. Buildings underlying the stoa and stoa terrace (Williams 1972, Fig. 5).

Previous Scholarship: Discussion of Broneer's reconstruction

The first attempt to present a full study of the South Stoa occurred with Oscar Broneer's publication in 1954, *The South Stoa and its Roman Successors*. Broneer's publication focused on the Greek and Roman phases of the stoa as well as some discussion of building remains in the vicinity which predated the stoa. Broneer's study deserves merit for being an ambitious presentation of an important secular building, and his discussion of the remains synthesizes the excavations he directed within the stoa. At the same time, his method of discussing the evidence was selective and focused on those parts of the building which he found especially interesting. An example

of this is the great amount of detail put into the discussion of the foundations, nine pages worth, while the Doric capitals are treated in less than a paragraph. The unevenness of the coverage is heightened by the style of presentation, which emphasizes certainty even when it is clear the evidence is inconclusive.³⁵

Perhaps more problematic is the fact that most of the excavation of the stoa is discussed superficially and the location of material recovered is only identified in terms of general area in which it was found, while no indication is given as to the exact levels in which material was found; for example material at the east end of the building, or from fill in the shop wells.³⁶ This situation extends back to the recording practice in the notebooks for the excavations as well. Knowing the general area may provide some help in identifying the location of certain elements in the reconstruction, but in no case is this secure and additional information regarding the context layer would have been helpful, particularly in determining any of the phases of destruction and refurbishments to the building.

Due to work on the stoa done subsequent to Broneer's publication, several of his conclusions are called into question. First, Broneer proposed a single storied facade with a second floor above the shops at the back for the initial phase of the building, citing evidence for staircases in the first and last

³⁵ One example of this occurs in the discussion of the geison blocks (1954, 38), where a second set of dowel cuttings at the back top surface of the frieze blocks led Broneer to the conclusion that the cornice stretched to the back edge of the frieze depth in some places, meaning that "ceiling beams and rafters must have been fitted into cuttings at the rear edge of the cornice blocks." Alternatively, since no cornice blocks are preserved to this depth, it is entirely possible that the dowels at the back edge of the frieze secured the ceiling beams and/or rafters, as discussed below.

³⁶ For example, discussing the fragments of piers used in the second storey reconstruction, Broneer says these were found "in various parts of the building and in some of the wells" (1954, 70). See below for a discussion of these piers and their possible position in the building.

rooms at either end of the building as the main evidence for his reconstruction.³⁷ **Fig. 2**

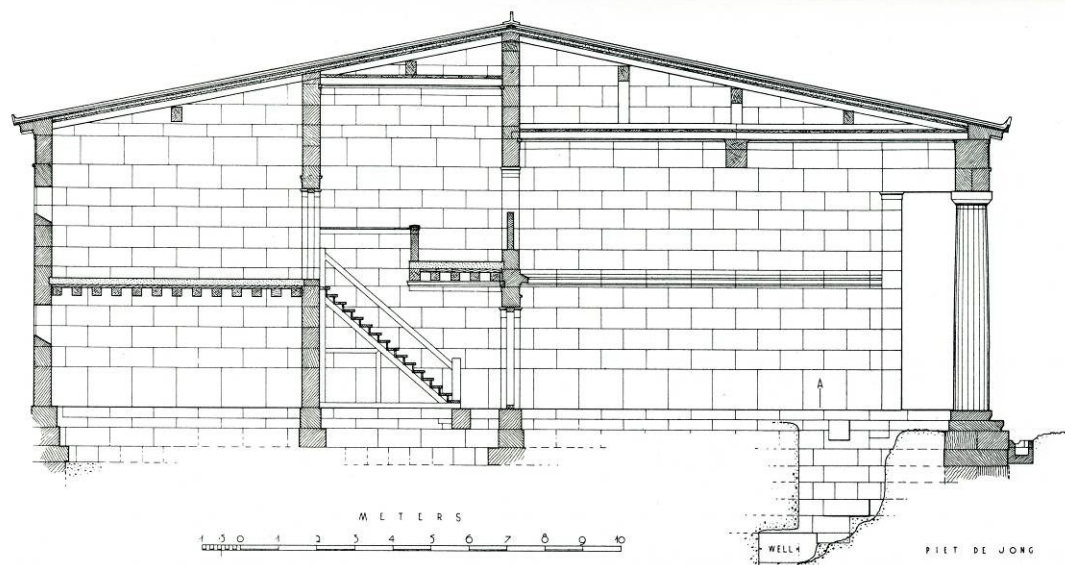

Fig. 2. Broneer's section at east end showing reconstruction with staircase inside the first room (Broneer 1954, pl. XI).

Broneer's reconstruction of the stairs in the rooms in the initial phase went unquestioned until Williams presented evidence from his excavations at the west end of the building, proving that a staircase existed in the colonnade prior to 146 B.C., and therefore most likely dating to the initial phase of the building, which went out of use probably just after the sack of Corinth by

³⁷ Broneer 1954, 68-70, 97. What at first would seem like an extremely low profile for the façade, with just one storey, is offset by the fact that the proportions of the order are enlarged to account for the height needed in the interior. There is no secure parallel for this split level design in monumental stoas before or later. The South Stoa in the Athenian agora, dated to the 5th c. B.C., was tentatively reconstructed with a second storey at the back and a single storied façade on the grounds that the road level behind the building would have been at the level of the first storey cornice (Thompson 1968, 46-8). This idea has since been challenged due to a lack of evidence and complications concerning the supporting mudbrick walls (Coulton 1976, 44). Stillwell suggested a similar arrangement of single storey façade with two-storeys of rooms behind for the North Building on the Lechaion road (1932, 212-28), but this was rejected by Coulton (1976, 52-53). These buildings are discussed in detail below concerning multi-levelled stoas.

Mummius.³⁸ **Fig. 5** The stairs in the colonnade would have given access to an upper floor, presumably in front of the north wall of the rooms and possibly indicating that the upper floor may have extended to the front colonnade. If this were the case, then the stoa would have had a two storied façade, making it among the earliest stoas in the Greek world to have one.³⁹ Re-examination of the foundations in Room I and XXXIII indicates that these foundations for stairs belong to a refurbishment of the building after 146 B.C.⁴⁰ At the east end in room I makeshift foundations of a different character from the original construction of the building have been inserted to support the stairs. These foundation blocks are not bonded to each other and do not bond with the front wall of the shops, as do all of the other cross-wall foundations for the rooms.⁴¹ **Fig. 3**

³⁸ Williams 1980, 127 and Fig. 5; also p. 130 for destruction date.

³⁹ See discussion of the stairs and alternative reconstruction below.

⁴⁰ Williams (1980, 130 n. 23) had already suggested the stairs inside the rooms were a later addition in the Roman period.

⁴¹ More problematic for Broneer's arguments regarding these stairs, a wall block with a slanting taenia used in the initial phase of the building was found imbedded in this cross wall (Excavation N.B. 183, p. 104). As will be shown below, this block was used in the stoa prior to the building's partial collapse and refurbishment when it ended up as spolia in the cross wall.

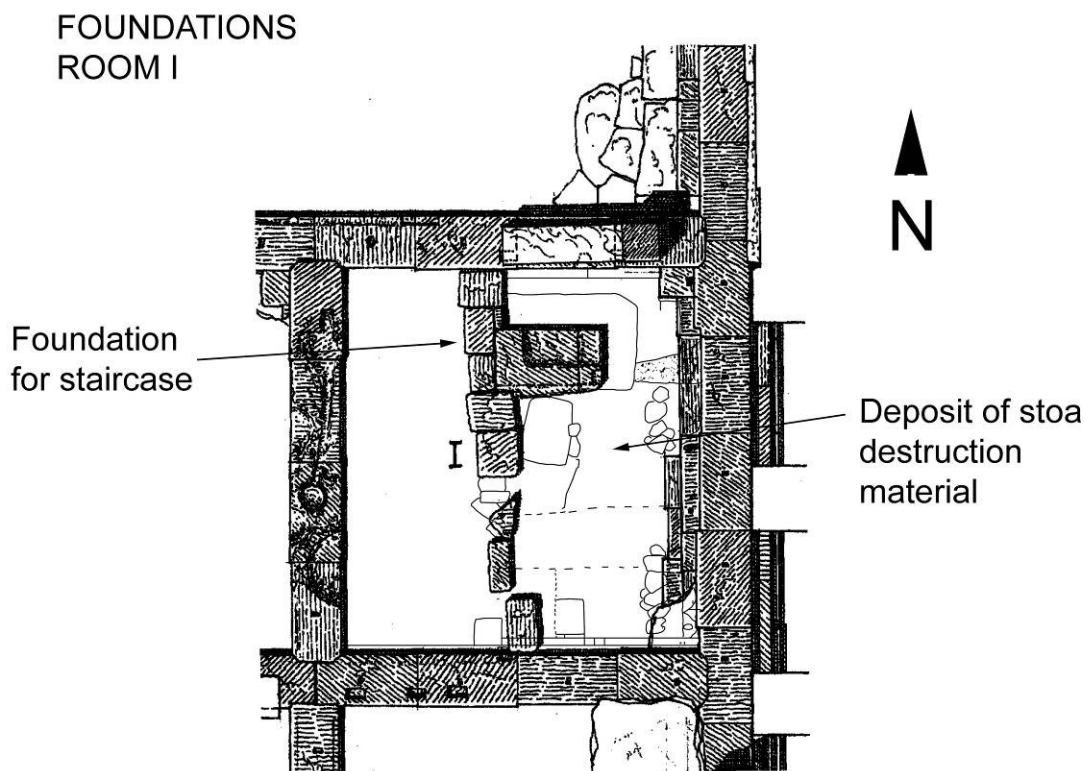

Fig. 3. State plan view of Room I showing interior foundations for staircase. After Broneer 1954, Plan I.

Additional evidence points to a disturbance in room I connected with the staircase. Inside this room, against the east wall foundations of the stoa and in the area beneath the staircase, was a “deposit” containing pottery and other material, the majority of which dates from the third century B.C. up to the time that the stoa was at least partially destroyed by Mummius in 146 B.C., and some material is said to date possibly after the re-founding of the Roman colony in 44 B.C.⁴²

That the fill was later than the construction of the stoa foundations is clear, since the footing trench for the east wall did not cut through the fill, but

⁴² For the date and character of the deposit see Edwards 1975, 224, no. 94. According to Edwards “the bulk of (the deposit) would seem to have gathered by the time of the destruction of the stoa by Mummius in 146 B.C.” Edwards goes on to say that it may indicate at least a partial destruction of the stoa at the time of Mummius and that some of the material in the deposit may date after 44 BC.

was cut by it, indicating the fill came later.⁴³ In the excavation notebook for this section Broneer also says that within this deposit was a layer of burned carbon over which was found “lime residue” mixed with Corinthian tile fragments of the type used for the roof of the stoa. This debris, in all likelihood represents a destruction layer of the roof. The tiles originally would have been bedded in or sealed with lime or some other type of mortar, such as marl, set on top of a wood framing (battens).⁴⁴ In addition to the roof tiles, among the debris of the burned layer was a lion’s head water spout of the same type used in the initial phase of the building.⁴⁵

The manner in which the foundations for the staircase were constructed and the disturbed nature of the deposit, which cut into the foundation trench, would suggest that the staircase was constructed after 146 B.C., during a refurbishment of the stoa in the early Roman period or after the re-founding of Corinth in 44 B.C. The debris from the roof is best interpreted as a result of a fire in the stoa during either the Mummian destruction of Corinth, or during the time period between 146 B.C. and 44 B.C. The foundations for stairs in room XXXIII, are also of similar makeshift character and should be seen as part of this later alteration to the building. The evidence associated with these staircases, therefore, indicates that they are most likely not part of the original construction of the stoa.

⁴³ Broneer stated in the excavation notebook that the fill should be dated after the initial construction of the stoa.

⁴⁴ See also Edwards 1975, 225. One of the Corinthian tiles (FS 654) joins a tile (FS 512) which comes from the fill of well II in the stoa. The well deposit is considered to be dumped fill of the cleanup from the destruction in 146 BC.

⁴⁵ The lion’s head waterspout appears in the card catalog of the museum inventory; however, as of 1990 it is listed as missing from the shelves and may have been used in the roof reconstruction on site.

While it might still be argued that the stairs inside these two rooms were a replacement for original stairs that needed extensive repair in the Roman period, evidence for another staircase inside the colonnade belonging to the Greek phase of the stoa obviates the need for stairs inside the rooms prior to 146 B.C.⁴⁶

Broneer's strongest argument for making the stairs in the first and last rooms part of the original design is the fact that the doorway between room XXXIII and the annex room behind is offset on the opposite side compared to the "normal" arrangement in the other rooms.⁴⁷ **Fig. 4**

⁴⁶Moreover, it is difficult to see such crude foundations as part of the original stoa design. Another scenario would be that originally there were better foundations which for some reason had to be replaced, or no foundations accompanied the original stairs. Both of these scenarios seem unlikely.

⁴⁷ Broneer 1954, 70.

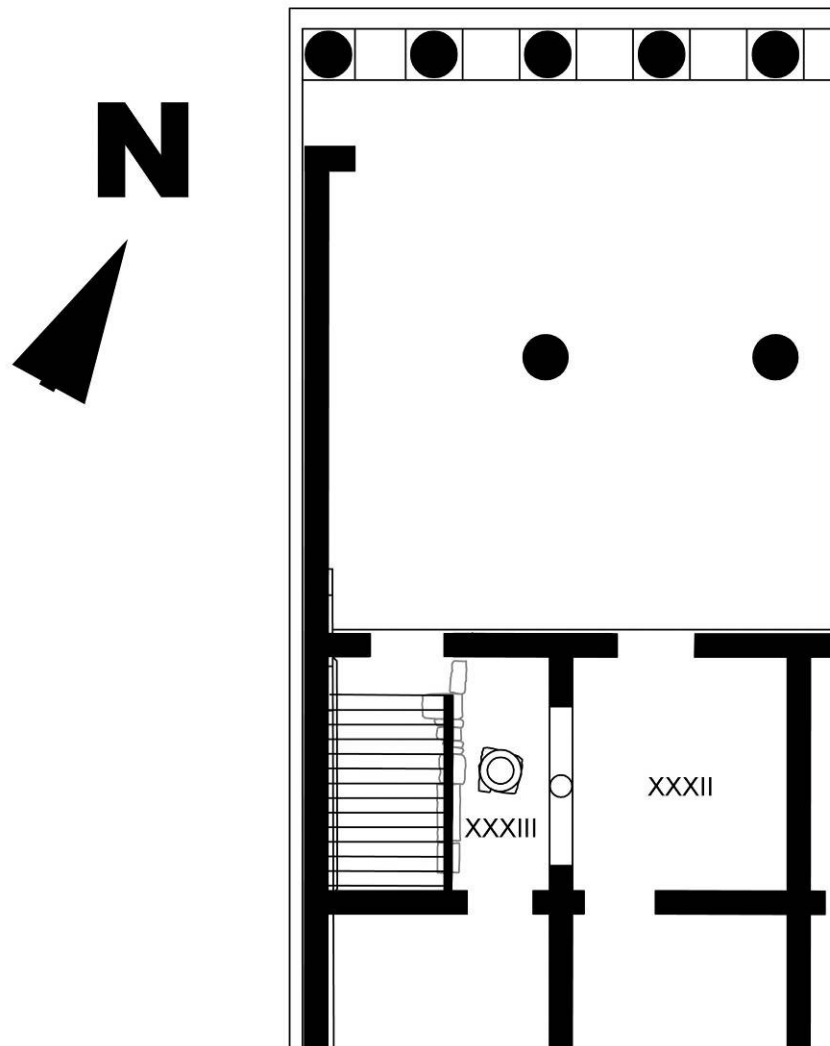

Fig. 4. Plan of rooms XXXII and XXXIII showing offset doorways, the staircase and well with possible passageway between rooms. Note the cramped nature of room XXXIII if restored with stairs and well.

The same condition, however, exists in rooms II to XXXII, where there is no staircase or feature that would require it. The offsetting of the door in Room I to the opposite side seems to be a means to add a measure of symmetry at the two ends of the building rather than for the purpose of accommodating a staircase. The wall in this position also provides more support for the side wall of the stoa, while if a doorway is closer to the sidewall it would reduce this supporting role. Broneer's other argument in favor of the stairs as original is that the well in room XXXIII is set opposite the stairs and is

excluded from room I.⁴⁸ The wells are not exactly centered inside the rooms, so its offset placement in relation to the stairs is of no significance in terms of planning.⁴⁹ The question as to why there is a well in room XXXIII and why it is directly in the path of foot traffic to the back room, or why this well was not placed in the adjoining room XXXII instead of the last room with the staircase, to match the condition at the opposite end of the building, was not satisfactorily addressed. If, however, the stairs in the back rooms were put in during the Roman reconstruction of the stoa, by which time the wells were out of use and covered over, then we can dispense with the problem of the cramped nature of the room. As a footnote, the passageway between rooms XXXII and XXXIII cannot be precisely dated and also may have been inserted after the well went out of use.

In addition to the above issues, the design layout of the upper floor is also problematic. At the back of the upper floor Broneer had put a hallway, or gangway, to facilitate passage between rooms.⁵⁰ **Fig. 2** Broneer's explanation as to why the passageway would be at the back instead of the front of the building is based on the evidence of anta capitals with slanting sides which he proposed to use as buttresses along the back wall of the stoa (see below).⁵¹

One major problem with this reconstruction is the fact that the rooms would be divided front to back by only piers and small columns along the buildings entire length, meaning that there would be little to no privacy between the front rooms and the passageway.⁵² Broneer's attribution of piers

⁴⁸ Broneer 1954, 70.

⁴⁹ This is dealt with further below in the section devoted to the construction of the well system.

⁵⁰ Broneer 1954, 75-76.

⁵¹ Broneer 1954, *ibid.*

⁵² Coulton, (1976, 57) points out the oddness of the arrangement concerning privacy.

and small columns in these positions was based on his assumption that this material had to go somewhere in the building, which while possible is not definitive.⁵³ Coulton suggested an alternative reconstruction for the upper floor rooms, moving the passageway to the front on the upper level, which would have facilitated passage into each of the rooms at the back through regular doorways and would also allow for placement of the piers on the front upper level overlooking the lower colonnade, therefore allowing more privacy in the rooms at the back.⁵⁴ While this might be an improvement on Broneer's reconstruction, it reduces the usable private space on the upper floor to just a fraction of the whole plan. **Fig. 5**

⁵³ This is dealt with in detail below in the discussion of the upper level of stoa.

⁵⁴ Coulton, *ibid.* As will be shown below, there is evidence for a gangway or balcony extending in front of the rooms of the upper storey, obviating the need for a passageway somewhere inside the rooms.

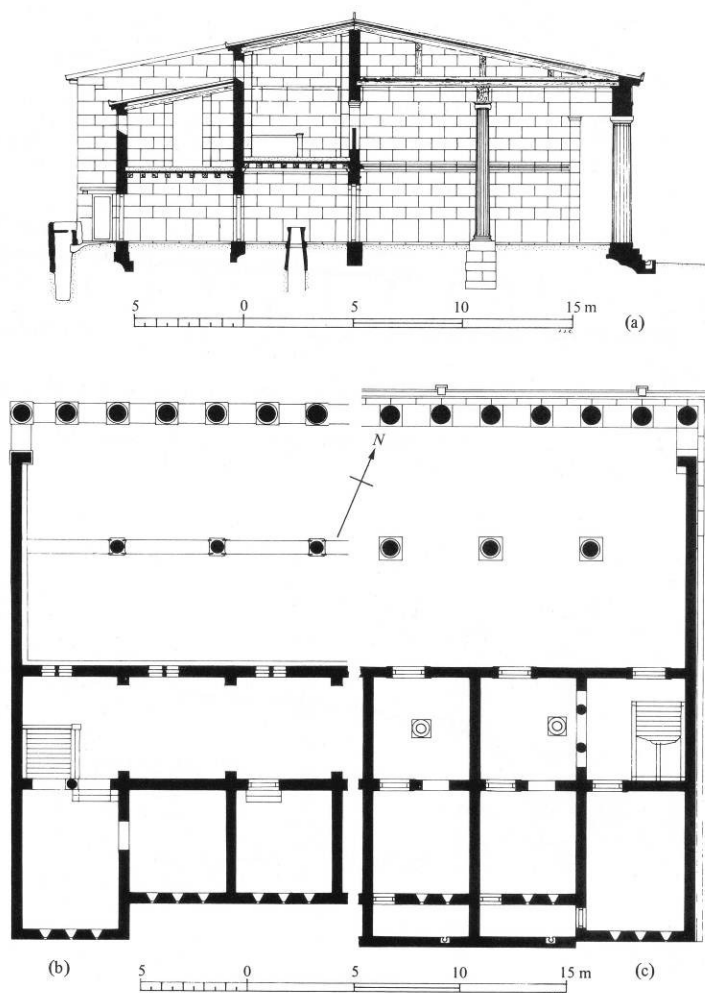

Fig. 5. (a) section, (b) upper and (c) lower floor plan of South Stoa, showing corridor of the upper level moved to the front (Coulton 1976 Fig. 13).

Evidence for Colonnade Stairs

In 1980, C.K. Williams' excavations at the west end of the stoa brought to light evidence proving that a staircase existed prior to 146 B.C. inside the colonnade against the west wall of the stoa. In the fifth orthostate of the west wall there are cuttings of two steps in the inside face of the block, ascending toward the north.⁵⁵ **Fig. 6 and Fig. 7** Foundations for a landing just to the

⁵⁵ Williams 1980. The cuttings in the west wall for a staircase can clearly be seen in the photograph, Plate 2.2 in Broneer 1954, but Broneer does not discuss them, nor,

south of the termination of the west wall anta indicate where a return should be. **Fig. 8**



Fig. 6. Orthostate in west wall with cuttings for stairs. View from east.

for that matter, were they ever mentioned in print before Williams (1980). It remains unclear why Broneer neglected to discuss the cuttings.

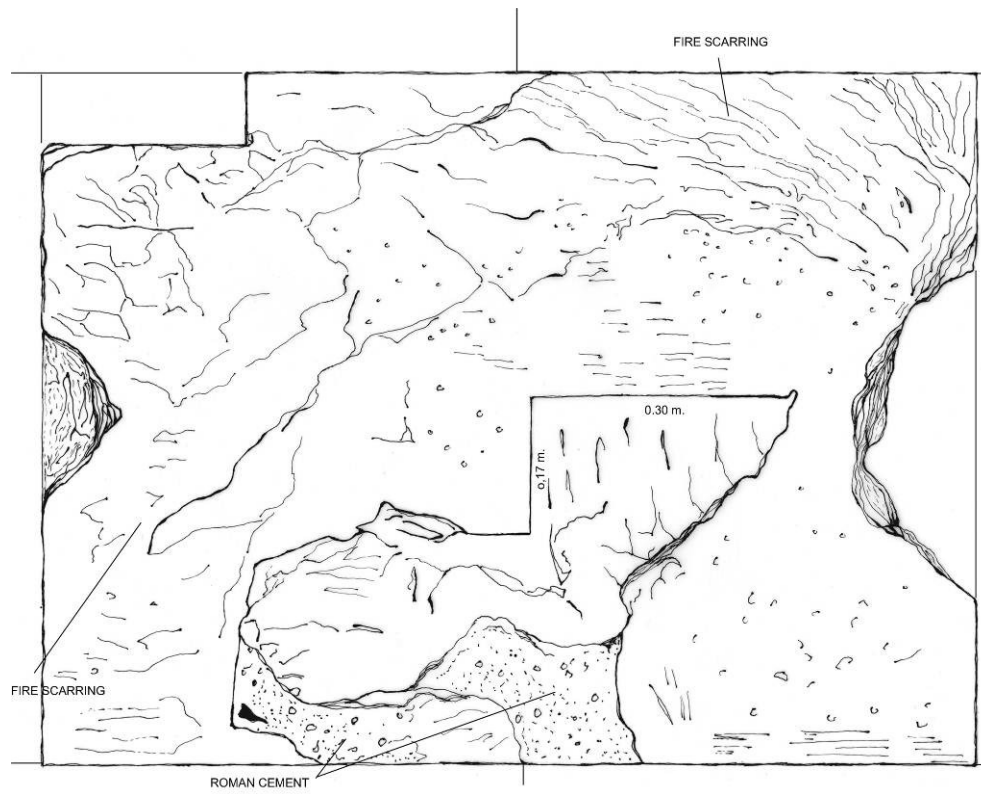

Fig. 7. Photo and drawing of step cuttings in orthostate of west wall.

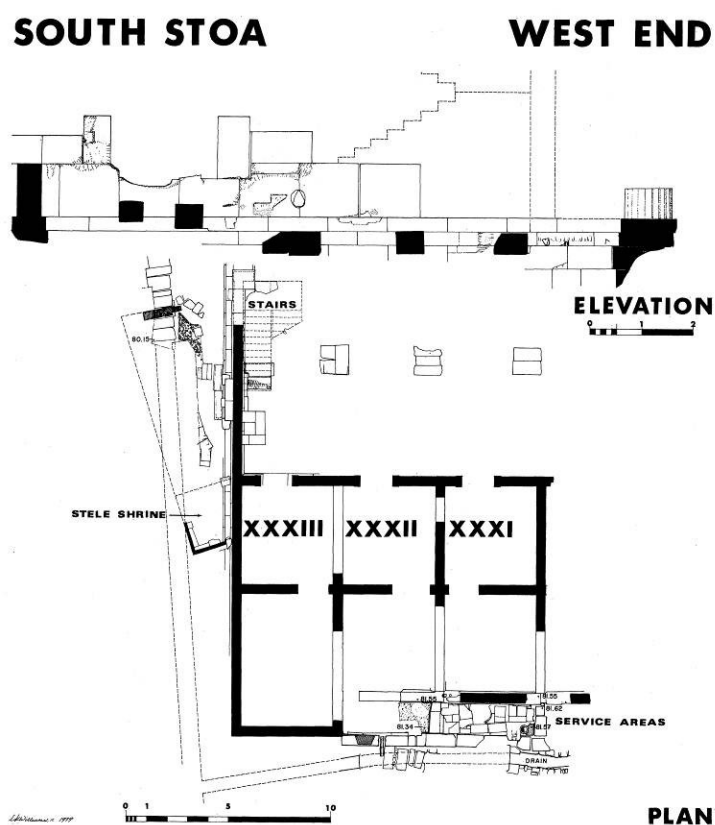

Fig. 8. Plan: West end of South Stoa, including Rooms XXXI-XXXIII. Elevation: West wall of Stoa colonnade (Williams 1980, 128, Fig. 5).

Based on pottery evidence, Williams stated that this stairway was constructed before the sack of Corinth in 146 BC and that the stairway foundations were out of use and covered in the Roman period when manhole 1952-1 of the Peirene system was re-opened.⁵⁶ This manhole is under the foundation of the west wing wall of the portico.

A staircase against the west wall in the colonnade suggests that the second floor should extend in front of the backrooms on the upper level, since, as reconstructed by Williams, the staircase itself would require an upper floor in front of the backrooms as a landing. This has considerable implications given that relatively few stoas of the late 4th or early 3rd centuries

⁵⁶ Williams 1980, 127 and Fig. 5; also p. 130 for destruction date.

B.C. had an upper storey.⁵⁷ In view of this evidence, Broneer's reconstruction, including the height of the upper floor as well as the heights of the exterior façade columns and interior Ionic colonnade, deserve re-examination.

New evidence has also come to light that corroborates Williams findings regarding the staircase and design of the interior of the stoa. Pier column fragments, found in the forum, suggest a new arrangement for the internal colonnade. A re-evaluation of the Ionic column height shows that the internal colonnade was probably lower than previously thought and, in fact, low enough that it may have had a balcony above on which the pier columns rested.

In addition to the above issues, Broneer's restoration of the roofline at the back of the building is also problematic. He restored a break in the roof at the back so that the roof above the rooms inside the two end wings is at a lower level.⁵⁸ The only evidence for this lower roof is a single block with a slanting taenia and one roof tile with an upturned side. It is shown below that the block with slanting taenia possibly belongs in the pediment. The roof tile with upturned edge could go on the back wing of the stoa or on another building altogether. These issues are discussed below regarding the roof construction.

It is fair to say that some of Broneer's proposals for the design of the building cannot be supported, given that evidence and comparative examples are lacking and that other evidence shows the possibility of a different reconstruction. The evidence, however, does support a split level design in

⁵⁷ So far, only the East Stoa in the Asklepieion at Athens and the L-shaped Stoa by the harbor at Perachora had upper storeys extending to the front colonnade before the third century B.C.

⁵⁸ Broneer 1954, 82-83 and see Plate XIVb.

the interior, which makes the stoa unique with the exception of possibly one other known example, South Stoa I in the Athenian Agora, from the 5th century B.C. What follows is a detailed presentation of the building from foundations to superstructure with a re-evaluation of the evidence for a restoration of the stoa.

Part II

Chapter 1

Materials and Techniques of Construction

The South Stoa appears to have been constructed of local Corinthian limestone, which is often referred to as poros limestone.⁵⁹ It is impossible at this point to say where exactly the limestone came from as there are several locations in the Corinthia from which blocks were quarried in antiquity.⁶⁰ Two of these quarries, both of which seem to have been used mainly in the Roman period, exist within the forum itself or nearby; one at the east end of Temple Hill and one in the area from which the Fountain of Glauke was constructed extending north to the cavea of the Roman Odeon.⁶¹ The next closest limestone quarries are near Examilia, 4.5 km ENE of ancient Corinth.⁶² The

⁵⁹ In modern scholarship the term “poros” limestone is often used to identify a variety of soft limestones. For the use of the term πῶρος in antiquity see Orlandos 1955-1958, 2, 68-70; also Burford 1969, 168-171. In modern Greek πῶρος λίθος refers to porous stone in general. Broneer referred to the stone used as “soft grey poros” and noted that “all public buildings of pre-Roman era” at Corinth are of this stone (1954, 6). The scientific term for “poros” limestone from many of the quarries in the Corinthia is oolitic according to Hayward, (1996 and 2003), but so far no samples from the ancient buildings at Corinth have been taken to determine for certain whether or not their material makeup includes oolites.

⁶⁰ See Hayward, 2003, especially p. 32; and 1996. Also for the Corinthian quarries see Wiseman 1978, 68, Figs. 71, 76; Freyberg 1973, 112-116. In the future, analysis of limestone samples from the building compared with samples from the Corinthia may indicate the source with more precision.

⁶¹ See Robinson 1976, 254; Broneer 1932, 142-143.

⁶² Other nearby quarries exist at Kleonai, Sikyon and Aigina. Kleonai, excavated by the Greek Archaeological Service, seems to have been the source for limestone used at the sanctuary of Zeus at Nemea (see Pfaff 2003, 28 n. 5). For another limestone quarry in the northern Corinthia, which has evidence of being under public ownership, see Lolos 2002, 201-207. For quarries on the north coast of Aigina, see Paton, Stevens 1927, 350.

type of limestone used for the stoa is relatively soft and easy to work.⁶³ The softness of the stone does not lend itself to fine details, however, and very fine stucco mixed with marble dust was used for finishing work on the surface of the blocks and columns. Where stucco was applied the surface of the stone would have been prepared with a flat chisel.

For the krepidoma, toichobate and superstructure one might expect a harder limestone to be used than for the lower foundations, but there seems to be no distinction in the fabric of the limestone used throughout the South Stoa.⁶⁴ Although Corinthian limestone might be considered insufficient for carving details due to its softness, the final surface would have been given a fine coat of stucco which would allow it to be used for such purposes. As soft limestone of this kind is more susceptible to weathering than harder stones due to its porosity, applying stucco to the exposed surfaces would have provided the surface with some degree of protection.

Wood

Wood was used for roof timbers, ceilings and door frames of the stoa as well as *poloi* and *empolia* of the columns.⁶⁵ Wood was also used presumably for the interior epistyles, the stairs and for the balcony along the

⁶³ The specific weight of limestone varies considerably for any given quarry due to differences of porosity and makeup of the sediment. Oolitic limestone similar to that in the Corinthia has a general specific weight of around 2000 kg/m³. By comparison, Portland Jurassic Oolitic stone has a weight of 2307 kg/m³; The Bulk Specific Gravity for Bath stone 1-4 ranges between 1988-2126 kg/m³.

⁶⁴ Buildings constructed in limestone at Corinth before the Roman period do not appear to have any discernable distinction in fabric between foundations and superstructure, as opposed to buildings which use a variety of limestone with different grades of hardness or color. For instance, see Pfaff (2003, 27-30) for the different limestone used in the Temple of Hera at the Argive Heraion.

⁶⁵ For varieties of wood used in Greek architecture see Meiggs, 1982, pp. 201-202, 423-457.

front wall of the back rooms. No wood has survived, but evidence in the form of cuttings exists for empolia and poloi of the column drums and for the door jambs. Special rebates were cut in the back of the frieze blocks and interior blocks at the ceiling level to receive wooden molding strips. The size and placement of roof timbers and ceiling beams can be extrapolated from the evidence of the cuttings in certain of the wall blocks.⁶⁶ The Doric column drums have empolia cuttings on both top and bottom and cuttings exist on top of the Doric capitals, but the bottom, or lowest, drum was not secured to the stylobate in this way.⁶⁷ The Doric architrave also appears to have a dowel cutting which would correspond to the empolion in the top of the capital.⁶⁸ The interior Ionic column bases also have evidence of an empolion in the top surface, but not the bottom.⁶⁹

Metal

Evidence for the use of metal for clamps and dowels can be deduced from cuttings and it is assumed that the iron clamps were seated in lead, though no traces of either exist. The type of clamps used in the initial construction were Π-clamps and these were placed sparingly only in certain parts of the superstructure, including upper wall blocks, the architraves and the cornice.⁷⁰ No clamps or dowels were used to fasten the frieze blocks, as it

⁶⁶ This is discussed in detail in the section on the roofing below.

⁶⁷ Cuttings for empolia and poloi to secure the lowest drum to the stylobate were employed in buildings of the 4th century (see Pfaff 2003, 91, note 23). Those noted by Pfaff are the tholoi at Delphi and Epidauros, the Temple en calcaire at Delphi, the Temple of Athena Alea at Tegea, the Temple of Zeus at Nemea and the Temple of Zeus at Stratos. To what extent this was common practice in the fourth and third centuries remains a question.

⁶⁸ See discussion of the architraves below.

⁶⁹ See below on the Ionic base.

⁷⁰ See Orlandos 1955-1958, 2, 178, 179, 191-192, 196; Martin 1965, 239, 283-287.

must have been thought that since these blocks were equal to the thickness of the architrave and backers the frieze did not need to be secured.

Cross Wall Bonding

The foundation blocks of the stoa are abutted one to another without the use of clamps, but where the foundations are visible the joints are still very tight. On the corners of the building the joints are angled and the toichobate blocks of the back rooms are joined by means of a peculiar system of jointing that deserves attention. The blocks are interlocked with chamfered ends set into the intersecting blocks which have a negative cut-out to receive them.

Fig. 9

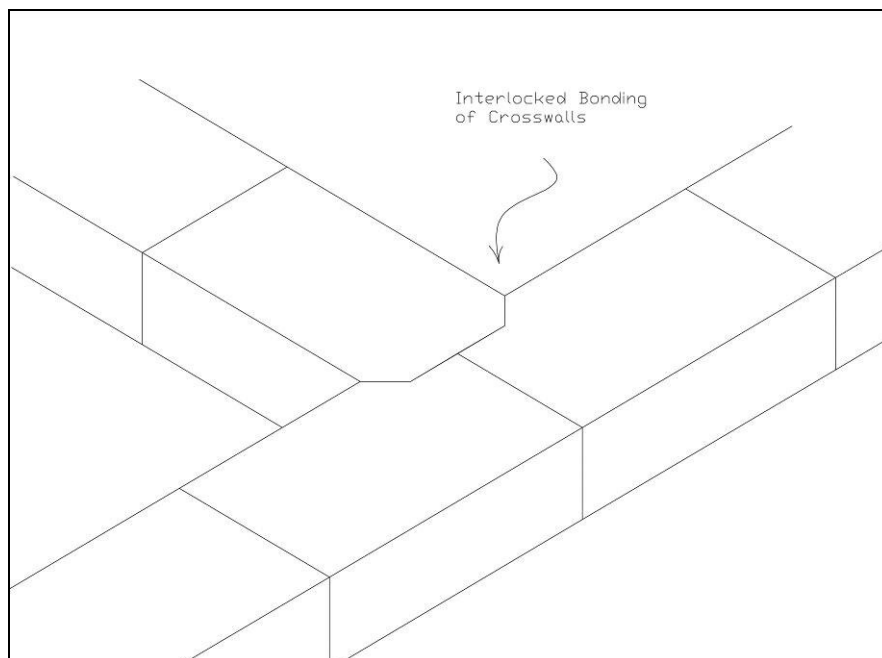

Fig. 9. Bonding of north-south cross wall with north wall of back rooms.

This interlocking system in the foundations provides a degree of stability without the use of clamps, which are absent in all blocks other than

parts of the superstructure. Interlocking or otherwise bonded foundation blocks are not uncommon in Greek architecture, but this particular type of bonding with carefully cut, or beveled, edges does not seem to have been repeated elsewhere except at Delphi in the 4th century foundations of the Temple of Apollo. At Delphi, the foundations employ rows of blocks, spaced a few meters apart, with single blocks interlocked at both ends between two rows.⁷¹ **Fig. 10** The purpose would seem to be for the same reason as in the South Stoa, that is, an attempt to add stability to the foundations in the event of seismic activity.⁷² Both the angled joints at the corners of the building and the mitered joints of the backrooms are reminiscent of carpentry.

⁷¹ Courby 1927, Figs. 21-23. Hansen 1991, p. 75, Fig. 4. See also Martin p. 466-68 and Figs. 203-205 for a discussion of how this system is reminiscent of carpentry. The connection between Corinth and Delphi regarding the use of this construction method is already substantiated by the fact that inscriptions from Delphi mention the employment of Corinthian stone cutters and Corinthian limestone for the rebuilding of the Temple of Apollo at Delphi in the second half of the 4th century. In addition the temple was said to have been constructed by a Corinthian architect, Spintharos, though later two more architects are mentioned, Xenodoros and Agathon, while Praxias and Androstheneas were named as responsible for the sculpture. For the inscriptions, see Bousquet 1989, no. 31, lines 98, 101-102; no. 56 III, lines 15-19; no. 59; no. 62 IIA, lines 1-2. Since this particular construction method seems to occur only in these two buildings and was not repeated again elsewhere, as far as can be determined, it raises the question whether or not it is a particular Corinthian construction technique used during the second half of the 4th century. Furthermore, if this technique is only used at Delphi and Corinth, it raises the possibility that the two projects were carried out by the same team of architects and/or masons. This would mean that the construction date for the temple of Apollo should be relatively close to that of the South Stoa. A possible scenario would have the Temple of Apollo beginning construction in the mid 4th century, continuing down to the last quarter of the century, and the South Stoa beginning construction sometime around 310 B.C. Since the foundations must be the first part of the refurbishment to be completed, it would mean that the technique was used around 350 B.C. and then again around 310 B.C., some forty years later. Traditionally the refurbishment of the Temple of Apollo is dated 366-326 B.C. For the date of the pedimental sculptures of the 4th century temple see Bousquet 1984, 695-98.

⁷² In other parts of the Peloponnesos a similar but less sophisticated form of this bonding exists, for example, in the cross-wall foundations of the Stoa by the Bouleuterion at Sikyon and in the Leonidion at Olympia. To my knowledge, this type of bonding is not attested for buildings outside the Peloponnesos other than Delphi, but this does not preclude the possibility of its existence.

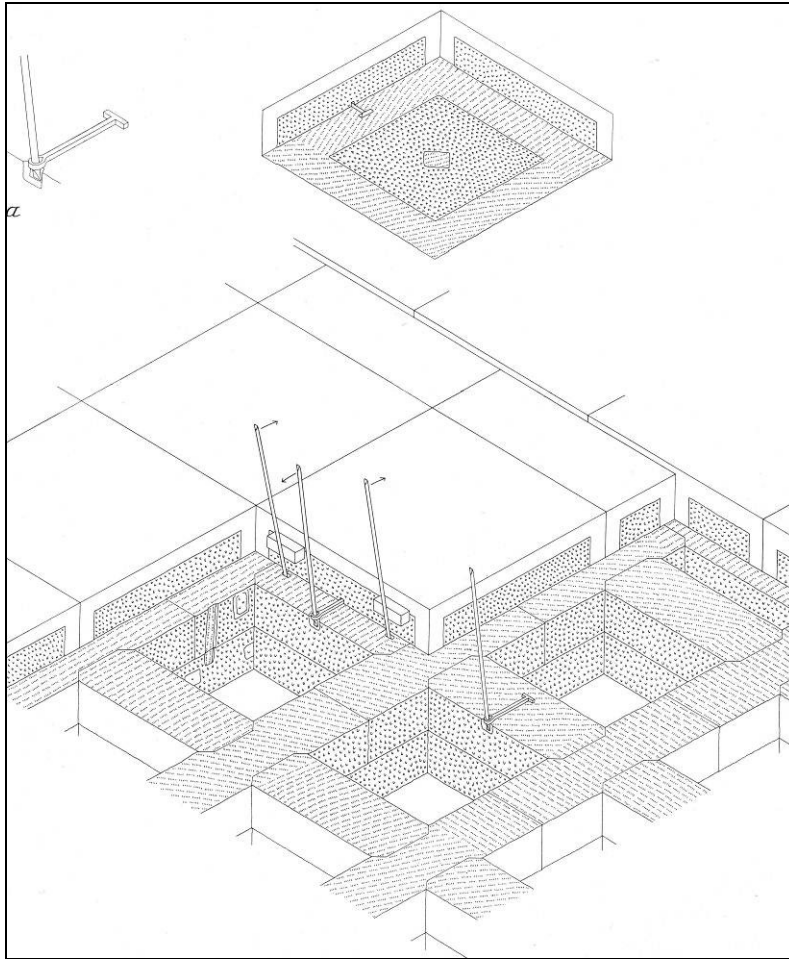

Fig. 10. 4th century B.C. foundations for the Temple of Apollo at Delphi. Showing bonding of blocks similar in character to the South Stoa at Corinth. E. Hansen 1991, Fig. 4.

Tools and Techniques of Carving

For carving the soft limestone of the South Stoa in the Greek period, flat chisels of various sizes would have been used.⁷³ These include narrow flat chisels for the clamp cuttings and other fine details, broader flat chisels for the

⁷³ Stillwell (1952, 18 and 35) noted that the contact surfaces (where visible) of the blocks for the Hellenistic gutter of the orchestra and the surfaces of the front wall of the skene in the theater at Corinth are very similar to the South Stoa. It is not clear what Stillwell meant by this. He refers to the broad margins of the anathyrosis, but this would seem to be too generic for comparison. The material is Poros, and therefore similar to the South Stoa, but this is also typical of many buildings and phases at Corinth.

interior regions of anathyrosis, and even wider flat chisels for visible surfaces and contact joints.⁷⁴

The tool marks often leave vertical parallel grooves or furrows, which are not always uniform and overlapping occurs. On the inside facing surfaces of the krepidoma blocks vertical grooves are carefully cut in two zones. This tooling contrasts sharply from foundation courses below. One would presume the first step and at least part of the stylobate of the krepidoma would have been below ground level on the inside of the building, especially since these inside faces also contain mason's marks. **Fig. 11**

On surfaces which were intended to take stucco, the surface was smoothed. For exposed blocks, such as the interior wall surfaces and the top surface of the stylobate, an abrasive was probably used to smooth the stone.⁷⁵ Interior wall surfaces, columns and moldings would have been smoothed and then given a fine layer of stucco.

⁷⁴ Blocks used in the Roman renovations of the stoa were sometimes treated with a claw chisel. This can be seen on the blocks of a Roman installation at the west end of the interior colonnade against the west wall.

⁷⁵ On sanding and polishing, see Orlandos 1955-1958, 2, 148.



Fig. 11. Vertical tool marks left by flat chisel on inside face of krepidoma, showing difference in tooling between krepidoma and euthynteria course below.

Stucco

Many parts of the exposed surfaces of the stoa superstructure received a fine coat of stucco.⁷⁶ Exterior walls were apparently not stuccoed. Only a

⁷⁶ Stucco may have been applied as a protective coating for limestone surfaces and whether or not it was intentional, it had this effect, though the exterior walls do not appear to have been stuccoed, perhaps because they were more roughly finished. Since stucco was often composed of marble dust, it would have given the otherwise tan limestone surface a bright white hue, mimicking a white marble surface. There are cases in which the composition was other than marble dust (ie. In a 4th century temple (Temple B) on the acropolis at Selinunte, the stucco is composed of dolomite).

few small traces of the original stucco exist on fragments of the geison, Ionic capitals and on the one Ionic base from the original phase of the building.⁷⁷

Lifting and Setting Devices

On the krepidoma blocks of the north colonnade there is evidence for lifting devices. On the first course beneath the stylobate, there are cuttings on the south side of each block midway between the top and bottom. One block at the east end has both a boss and a cutting below on the inside face. If the bosses and cuttings were for lifting, the opposite sides of the blocks would also have had a corresponding boss or cutting. The opposite side of the blocks, however, forms the front step with a triple banded molding cut into the bottom edge, so any boss or cutting that might have been on the front side of the block would have had to be removed in the final trimming and finishing of the course. **Fig. 12**

⁷⁷ There is evidence that at least some if not all of the Greek column drums received re-stuccoing in the Roman period. The lowest drum at the west end, still in situ, has a layer of thick Roman stucco preserved inside the fluting. One Greek Ionic capital also has a layer of thick Roman stucco in the fluting. In general the Greek stucco is much finer and thinner than Roman stucco.

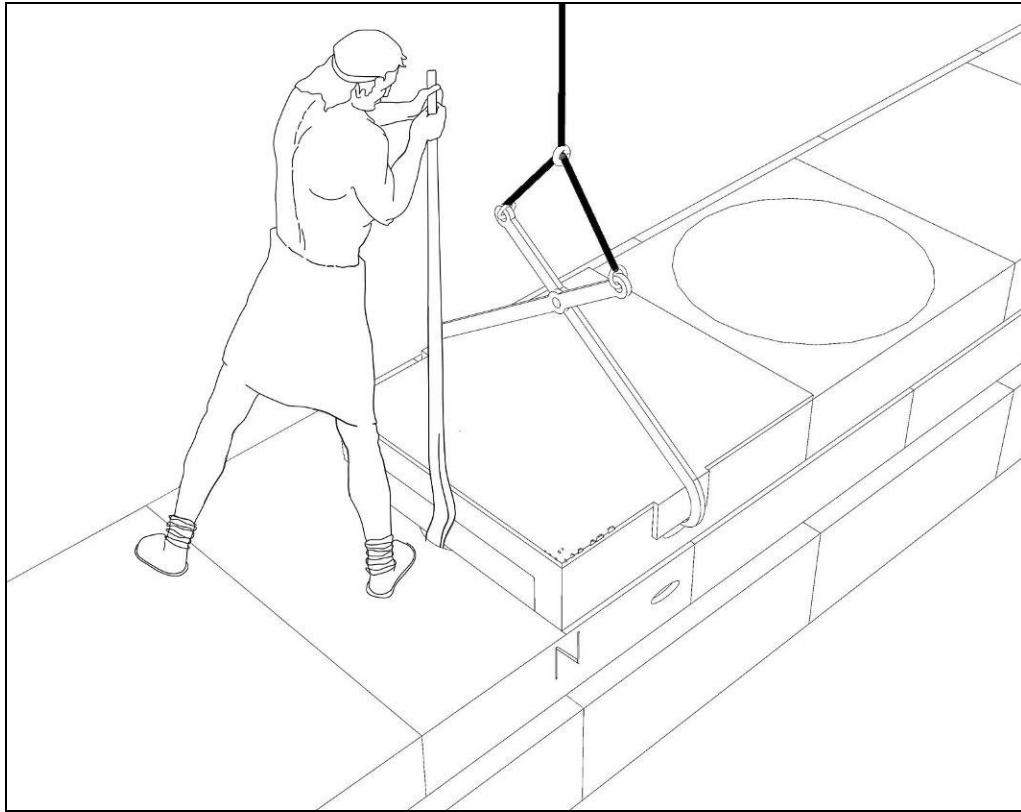

Fig. 12. Showing final setting of stylobate block into place. Tong cuttings, mason's marks and setting line visible on interior surface of blocks.

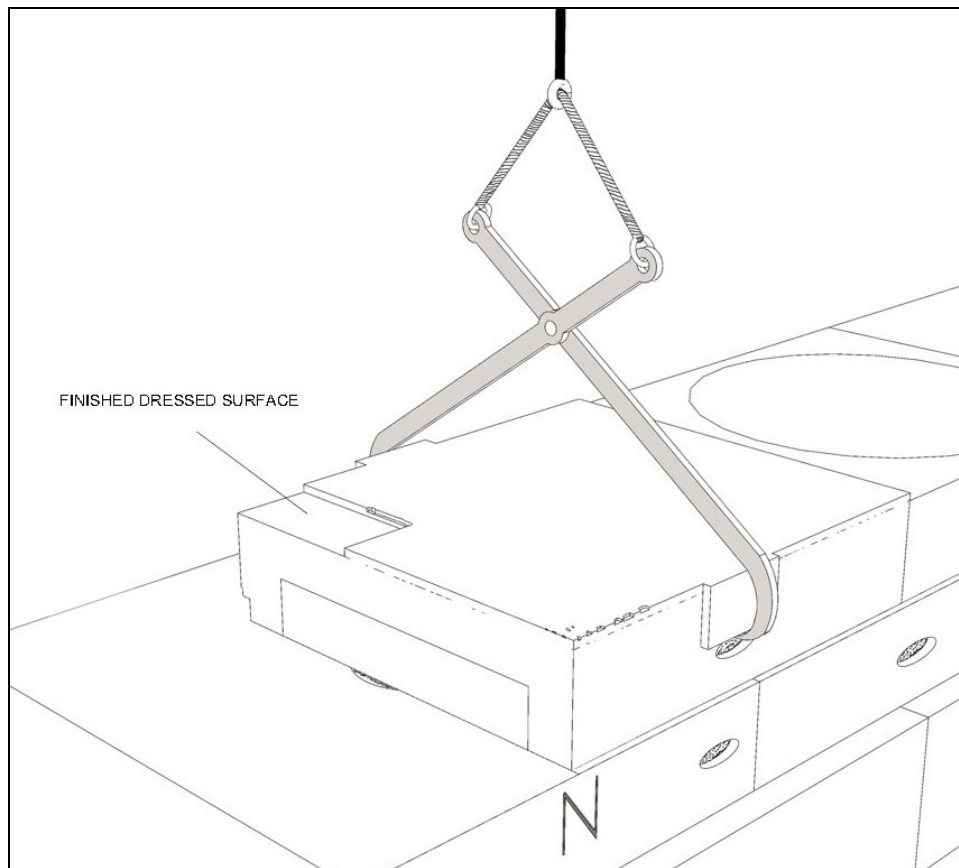

Fig. 13. Cuttings for tongs in krepidoma blocks, showing protective bosses for lifting.

The cuttings could have served to hold tongs pulled tight to the sides of the block when lifted from above.⁷⁸ **Fig. 13** Tong cuttings would be used in this position to allow the block to be set tight against the adjoining block. As the block is being positioned, a workman, pushing against the outside edge, could lever the block tight against the neighboring block using a crowbar. The cuttings are not always positioned in the middle of the block, which might suggest that they were used in the quarry before the block was cut down to specifications, but in that case they would have been part of the extra layer on the block that would be trimmed away. It is possible that, in addition to the

⁷⁸ For lifting tongs and lewis irons, see Orlandos, 170-175; Martin, 215-216, 218-219. That these cuttings are not just pry holes is certain, since they are midway up the sides of the block.

cuttings for tongs, ropes would be used for lifting and setting the blocks into position initially as a precaution, even on those blocks where the cuttings are centered. The ropes could then be pulled out before the block was set to rest.

It might be thought that setting blocks in this way would be excessive as a jib to hoist each block would have to be repositioned many times along the length of the building, but it is not beyond the realm of possibility and such a model for positioning blocks is shown in a Roman relief.⁷⁹

The lower courses of foundations of the inner colonnade have cuttings that employ a peculiar method used for lifting and setting blocks. The blocks were notched midway down on the four corners for the insertion of rope loops. This occurs in the foundations of the inner colonnade for the lower courses only.⁸⁰

No evidence of lewis cuttings exists on the blocks of the South Stoa.⁸¹ It might have been thought that lewis irons were not a safe way to lift the limestone blocks due to the softness of the stone. Moreover, for such a soft stone, the amount of carving necessary to make the lewis deep enough to safely lift the block might have prevented its use over other methods of lifting. Lewis cuttings do exist on blocks of similar stone elsewhere, however.

⁷⁹ Wilson Jones 2000, 28, Fig. 1.14 for a Roman relief showing a jib being used with tongs to hoist and set blocks.

⁸⁰ I know of no parallels for these cuttings. See discussion of inner foundations below.

⁸¹ Certain blocks would be more likely to have employed a lewis than others, such as geison blocks and other members of the superstructure. Since not all blocks of a particular course would necessarily have a lewis, this method cannot be ruled out for the South Stoa. We can only say that none have been preserved. If, for instance, the central metope of the frieze course was separately inserted, as in the Temple of Zeus at Nemea, which has a lewis cutting for slotting the middle metope into place after the other frieze blocks were apparently laid from both ends, it might be expected here too (see Hill and Williams 1966, 13-14).

The toichobate blocks, the wall blocks and some of the foundation blocks are beveled along the bottom edge on one side. For the wall blocks and orthostates, the beveled edge is on the outside lower edge. One possible reason for these beveled edges could be for setting the block along a setting line either incised or marked in chalk on the block below.⁸²

Setting Lines

Setting lines exist on the top surface of the second krepidoma step to indicate placement of the stylobate blocks and are visible on the upper surface of the orthostates. There are also setting lines on certain members of the superstructure. The frieze blocks of the lower storey have setting lines on their top surface to indicate the placement of the geison blocks. One corner geison block has a setting line for seating the raking geison. There are also at least two setting lines on the blocks of the first step of the krepidoma at either end of the building.⁸³

Clamps and Dowels

Clamps and dowels were used sparingly in the construction of the stoa, placed at key points of stress. The kind of clamps used in the initial construction was exclusively of the hook type, otherwise known as a Π -clamp,

⁸² Broneer 1954, 24, 40. As Broneer noted (*ibid.* 24), some of the lower foundations have a beveled lower edge. It is not possible to see all of these foundation courses now. There is no reason to bevel foundation blocks, which would be buried, for aesthetic reasons, so a functional reason is necessary. Perhaps it was employed as a means to check the line of the blocks intermittently as they were being set. Another possibility is that those foundation blocks with a beveled edge might originally have been meant for use elsewhere in the building, but I have found no supporting evidence to suggest that was the case.

⁸³ These are discussed in the section on the krepidoma.

evidenced by cuttings as no metal survives.⁸⁴ **Fig. 52** The architraves have hook clamp cuttings on their ends and a pair at the backs for joining to backers.⁸⁵ The frieze blocks have no evidence of clamps on their ends, but do have dowels on top for fastening the cornice.⁸⁶ One of the horizontal cornice blocks has a clamp cutting on one side for joining to the next cornice block and presumably both ends were clamped. The underside of the cornice must have had a dowel for fastening to the frieze course.⁸⁷ One block from the upper wall, with a taenia, has hook clamp cuttings on both ends.⁸⁸ Another block with a slanting taenia also has a hook clamp cutting on its preserved end.⁸⁹

The evidence might suggest that clamps and special bonding measures were used only for key parts of the building where additional stress might warrant an extra measure of safety and support, such as the intersection of walls and corners as well as certain blocks of the superstructure. One might suspect, however, that clamps were used more systematically throughout the entablature. Generally, clamps and dowels were used in the superstructure of the front colonnade and special jointing was used at corners.

⁸⁴ This type of Π -clamp is used in other Hellenistic construction at Corinth, including the Theater, while in the Theater H -clamps are also used.

⁸⁵ Broneer (1954, 33) noted that dowel cuttings existed on the bottom side of the architrave for doweling into the capital, but the preserved example appears to be a pry cutting.

⁸⁶ Broneer 1954, 36.

⁸⁷ Broneer 1954, 38, Fig. 14.

⁸⁸ Broneer 1954, 41-42. Broneer placed this block in the tympanum just above the horizontal cornice.

⁸⁹ Broneer 1954, 82, Fig. 60.

Chapter 2

The Foundations

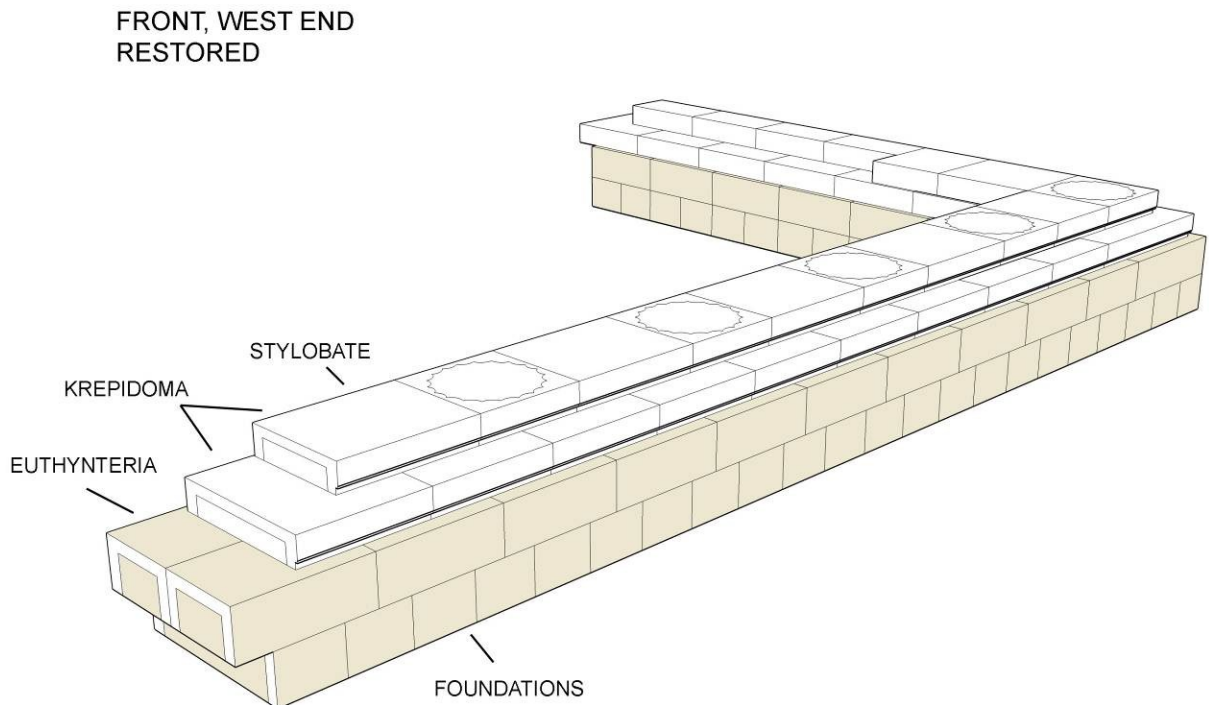

Fig. 14. Foundations of west end. Upper four courses restored. Showing system of headers and stretchers.

The foundations are constructed of limestone blocks in alternating courses of headers and stretchers. **Fig. 14** At the east end of the building there are four courses of headers and stretchers below the krepidoma, making the foundations 1.78 m. deep at this point. At the west end, there are eight courses, making the foundations ca. 3.50-3.60 m. deep at this point. This change in depth at the west end is due to the fact that the natural ground level slopes down from the southeast corner to the northwest corner of the

building. All the blocks have anathyrosis 0.15-0.18 m. wide on their contact joints.

In the sixth course below the stylobate, the headers are ca. 1.60 m. in length, 0.585 m. in width (one quarter the axial distance) and 0.47 m. in height. The fifth course below the stylobate is made up of stretchers ca. 1.17 m. in length, 0.80-0.82 m. in width and 0.43 m. in height. Course four is made up of headers like course six, but their height is ca. 0.43-0.44 m. Course three is made up of stretchers 1.17 m. in length, 0.79-0.80 m. in width and 0.445 m. in height. This top course of foundations, the eutynteria, on which the courses of the krepidoma and toichobate rest, is visible in several places along all four sides of the building, but is substantially robbed along the front façade on the north side. The eutynteria projects ca. 0.15 m. beyond the upper projection of the krepidoma on the front, and between 0.12-0.17 m. on the east and west sides.

Eutynteria Course of North Foundations

At eutynteria level, 14.70 m. west of the midpoint of the stoa along the north foundations, and almost in line with the middle of room XIV, there is a vertical cutting or slot that extends up to the full height of the back face of the eutynteria. **Fig. 15 and Fig. 16** The cutting is ca. 0.10 m. in width. The face of the block is rough and the depth of the cutting varies depending on where it is taken, but it is ca. 0.05 m. The back of the cutting is flat as though to take a vertical wooden piece. Since the back faces of all the eutynteria blocks are rough and therefore do not line up, it may be surmised that the cutting served to line up the next course above the krepidoma blocks. Indeed, the krepidoma

blocks are set back from the inside edge of the euthyneria in line with the back face of the cutting. The evidence of the cutting would suggest that a wooden block set inside the cutting could have held a string to establish a setting line. It is also possible that a wooden block in this position could have provided a survey line for checking straightness of the foundations.⁹⁰



Fig. 15. Vertical cutting in euthyneria course.

⁹⁰ Due to the length of the building, it would seem necessary to have several points where this was done. I have not noticed any other cuttings, but a large number of blocks from this course are missing. A parallel for these cuttings exists in foundations of the Roman Odeon at Corinth. See Broneer 1932, 19, Figs. 12 and 13, where he hypothesizes that the cuttings at the Odeon were for framework. It seems, however, that their purpose was probably similar to that proposed here for the South Stoa and that they were used as a gauge for setting the upper courses.

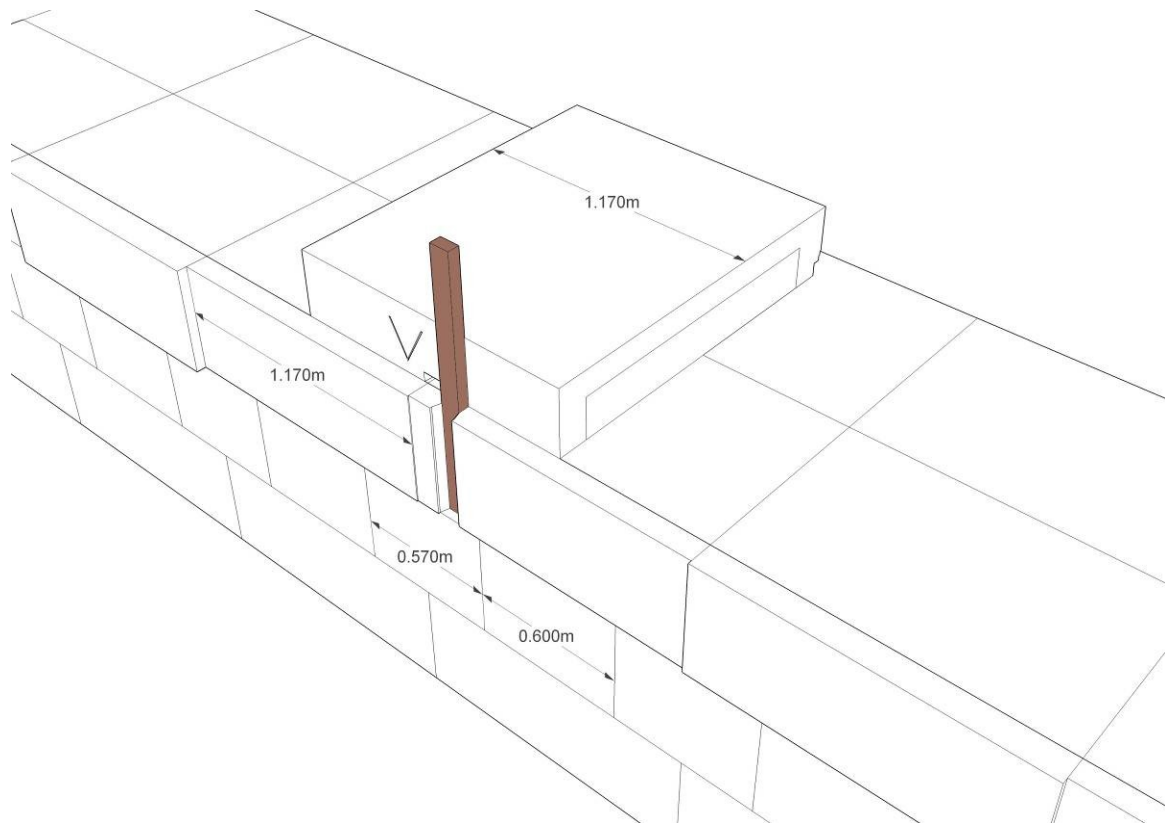

Fig. 16. Slot cutting in euthyteria of north foundations possibly to hold wooden piece for setting line of krepidoma. Occurs approximately midway along length of building.

This cutting is the only one preserved. Since much of the foundations along the front have been either partially or entirely stripped out, there may have been more such cuttings originally.

Interior Column Foundations

The interior column foundations consist of alternating courses of paired blocks forming piers, which, like the other foundations of headers and stretchers, would have been set in alternating rows for stability.⁹¹ Some blocks of the foundations have been robbed out completely, but the cuttings in the

⁹¹ The technique of using alternating pairs of blocks is not uncommon for interior column foundations in the Peloponnese. They occur in the interior column foundations of the Classical Temple and East Building at the Argive Heraion (Pfaff 2003, 62); also in the Hypostyle Hall at Argos (Bommelaer and des Courtils 1994, Pl. viii:d).

ground were visible when excavated, according to Broneer.⁹² Following his state plan and counting from the east, it appears that foundations 3 and 8 were excavated, but had been robbed; 9 appears to be unexcavated. The foundations for 10 are visible. The foundations for 11, 12 and 13 are not visible in the state plan. Interior columns 11 and 12 are directly in front of the monumental Roman entrance to the South Basilica. In Broneer's state plan these appear unexcavated. Foundations for 15 and 17 appear to be unexcavated with no visible stylobate blocks. Foundation 20 appears to be excavated, but did not have any blocks. Foundation 21 is partly cut away. Foundation 24 was excavated, but robbed. Foundation 25 has blocks but they appear to have been disturbed. From this it emerges that those with stylobate blocks still in situ are in positions 4, 5, 6, 16 and 31.

The foundations are as shallow as two courses at the east end. Heermance excavated one of the interior column foundations at the west end and exposed a total of six courses with a total depth of 2.73 m., but he did not specify which foundation. Broneer only excavated "a few" at the west end to the bottom.⁹³ The deepest of the interior column foundations during the excavations of the stoa was the foundation under the 28th column from the east end, which went down ten courses, due to the fact that it rests inside the east channel of the Great Reservoir.⁹⁴

⁹² Broneer 1954, 22.

⁹³ Broneer 1954, 22, n. 8. Broneer cites one foundation at the west end as five courses deep, but does not specify which one.

⁹⁴ Broneer 1954, 22. For the Reservoir channel under this column, *idem.* 12; also Plan VIII, section E1-W1.

The foundation blocks vary in length from 1.33-1.40 m. They are 0.66-0.70 m. in width, and as tall, or slightly taller in height than the stylobate blocks. The base slabs of the interior columns measure ca. 1.13 m. square, 0.42-0.46 m. in height, though it is not clear that these are original base blocks and not Roman period replacements. They are 0.10 m. above the level of the north stylobate. In the lower courses, the blocks have notches midway down along the corner edge on all four sides.⁹⁵ The notches are roughed out cuttings approximately 0.05-0.07 m. square used for lifting and setting the blocks into position within the narrow foundation trench cut for them. The cuttings would have served to hold ropes looped under them around each corner of the block. **Fig. 17**

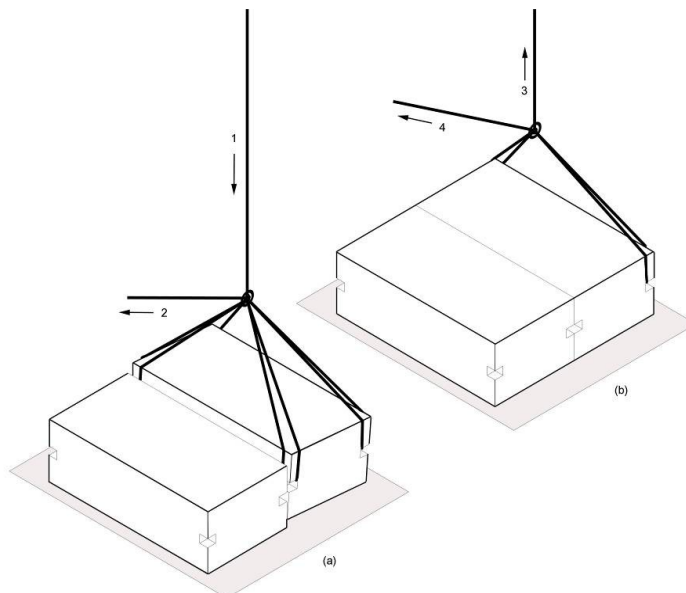

Fig. 17. Interior column foundations, illustrating technique to lower and set blocks: (a) Lowering the block into place. (b) Final positioning.

⁹⁵ See Broneer 1954, 22, Pl. 6₁.

After lowering the second block down into the foundation cutting, the ropes looped on the inside would have to be removed before the block could be positioned tightly against its neighbor. In order to facilitate this, a three step procedure would be needed; whereby the block was lowered at a tilted angle away from the first block until the outside edge rested on the ground and the inside edge was perched against the side of the first block. Once this was done, the inside ropes could be pulled out, leaving the outside ropes in place. By lifting the outside ropes slightly, the second block would slip into position, tight against the first block.

This method was chosen presumably because it was the fastest and most effective way to set the blocks, given the narrowness of the foundation trenches. Another possible solution would have been to use lewis cuttings, however this would have required carving out a substantial portion of the upper surface at the middle of the block. Moreover, a block suspended by its center would be harder to control from above without extra guidance by hand for final positioning.⁹⁶

⁹⁶ This type of lifting device, with cuttings on the corners, would only be necessary for lowering blocks into a narrow space where prying and shifting blocks would be nearly impossible and any maneuvering had to be done from above. I know of no parallels for these cuttings for lifting blocks. Lifting bosses can still be seen on blocks of the foundations for the columns of the ship sheds at the Zea harbor, where the foundation trenches are just wide enough for the blocks in some cases. Here, however, single blocks were used instead of pairs. Lewis holes are usually confined to blocks of the superstructure like the geison, which must be lifted high, but can be positioned from the sides with crow bars as the block is set. Another method would involve lifting bosses on the sides of the block, but bosses could not be placed on the contact sides in such an operation.

East and West End Foundations

The foundations beneath the toichobate of the side walls at the east and west ends of the building agree in dimensions and details with the front foundations, where they could be examined. The foundations of the east end cannot be seen, nor were they ever exposed in excavations. At the west end the foundations can be seen and at this end, just behind the anta foundations, the foundation blocks under the wall have been trimmed back against the wall for the purpose of accommodating stair foundations, extending back to the front wall of the backrooms. The trimming is not squared off at the corners and has a rough appearance. **Fig. 18** and **Fig. 19**



Fig. 18. West wall showing step cuttings. Toichobate cut back to accommodate original stair foundations.

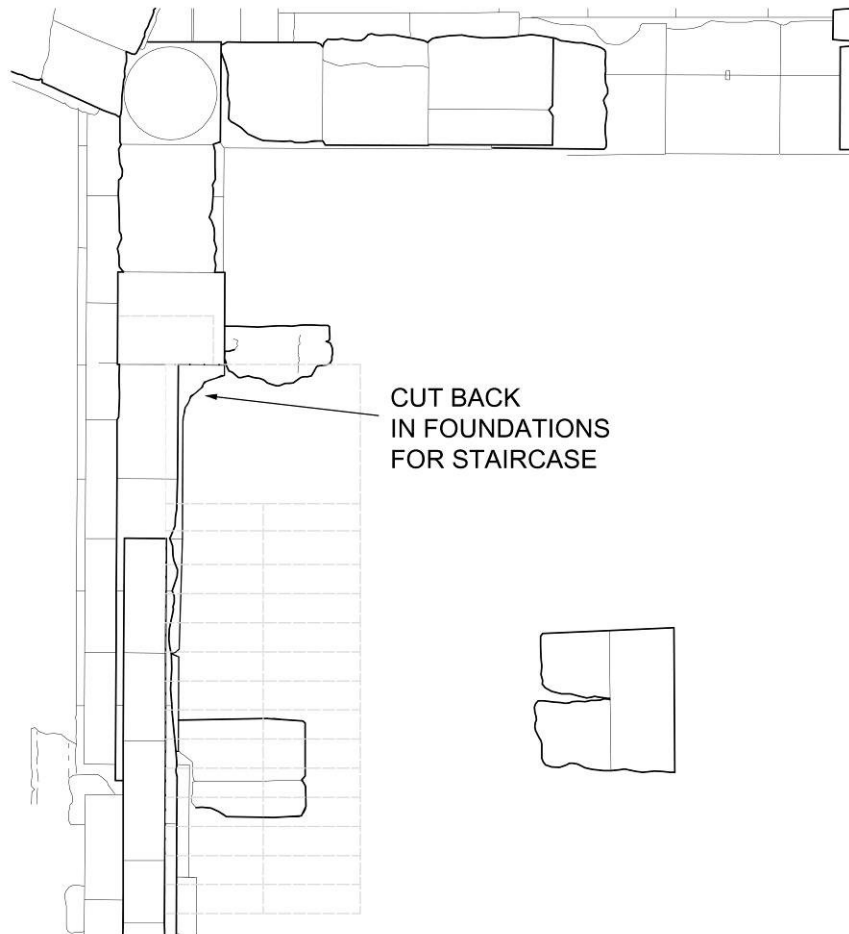

Fig. 19. State plan showing west end foundations, with cut-back for staircase.

Foundations of Backrooms

The foundations of the backrooms are visible in several places, although the lowest courses have only been exposed in a few places. The dimensions of these blocks deviate from the standard dimensions used for the blocks at the front of the building and along the sides, because the dimensions of the rooms were independent of the modular system set by the north colonnade. It could be that the builders deviated from the dimensioning system used for the front of the building, because they were intent on having a specific size and number of rooms within the overall length, independent of

the module used.⁹⁷ Another reason might have to do with the layout and use of the rooms, an idea explored in detail below. The east-west foundation blocks for the front wall of the backrooms, the interior east-west walls dividing the front and back rooms and the back wall measure ca. 1.24 m. in length as opposed to the modular system of 1.17 m. on the front of the building. There is some deviation in the dimensions of the blocks in the cross walls.

Euthyneria Course of Backrooms

The blocks of the euthyneria course measure 1.20-1.26 m. in length, 0.68-0.72 m. in width and 0.42-0.46 m. in height. At the east end of the building, the euthyneria course of the backrooms lacks foundations, whereas at the west end the foundations extend much deeper. In room XXXII, for instance, where the foundations overlay the Great Reservoir, there are two courses below the euthyneria course, consisting of two headers above the reservoir cover.⁹⁸

At the intersections of the east-west and north-south cross walls in the front and back rooms, larger blocks were inserted in the euthyneria course, which measure 1.64 m. (north to south) by 1.30 m. (east to west). Similar blocks of slightly smaller dimensions were set at the intersections of the cross walls with the back wall and front wall of the rooms. These blocks project from the toichobate course at the corners. **Fig. 20**

⁹⁷ The result is that the rooms do not line up with the colonnades. This is dealt with in more detail below concerning the design and function of the back rooms.

⁹⁸ Broneer 1954, 26.

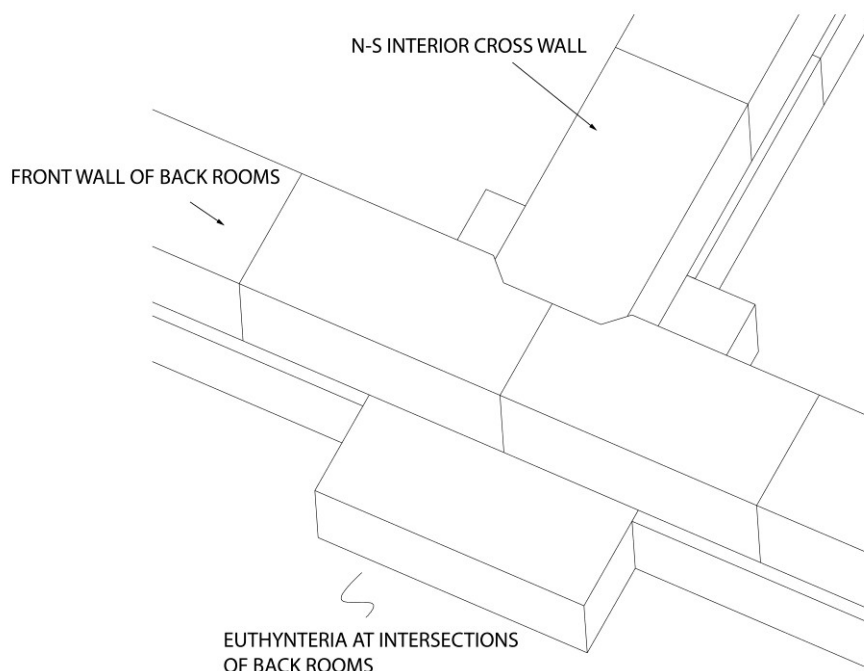

Fig. 20. Isometric view showing toichobate and euthynteria courses at intersection of front wall to the back rooms and dividing cross wall within rooms.

Broneer stated that the purpose of the larger corner blocks at the east end of the building was to provide “a firmer footing” since only one course of foundation is lying directly on stereo, while at the west end this was not necessary as there were two courses of foundations below the euthynteria, making the larger blocks in other parts of the building only for “consistency” in construction.⁹⁹ It would seem, however, that an even more important reason for the larger blocks at the intersections throughout all of the backrooms was to provide additional stability and support for the upper storey exactly at the corners of the rooms, where it would be most useful.

⁹⁹ Broneer 1954, 26.

Backroom Dimensions at Foundation Level

The normal east-west width for the backrooms is 4.95 m. center to center on the walls, except the first and last rooms. The interior width at the toichobate level is 4.48 m. This axial dimension of 4.95 is based on thirty-three room divisions within the overall length [164.38 minus 0.63 (the width from the center of the wall to the edge of the toichobate is 0.315) divided by 33 equals 4.96]. Interestingly this division of rooms contrasts with the modular rhythm used on the front and sides of the building **Fig. 21**.¹⁰⁰ The difference amounts to 0.13 m. per bay.

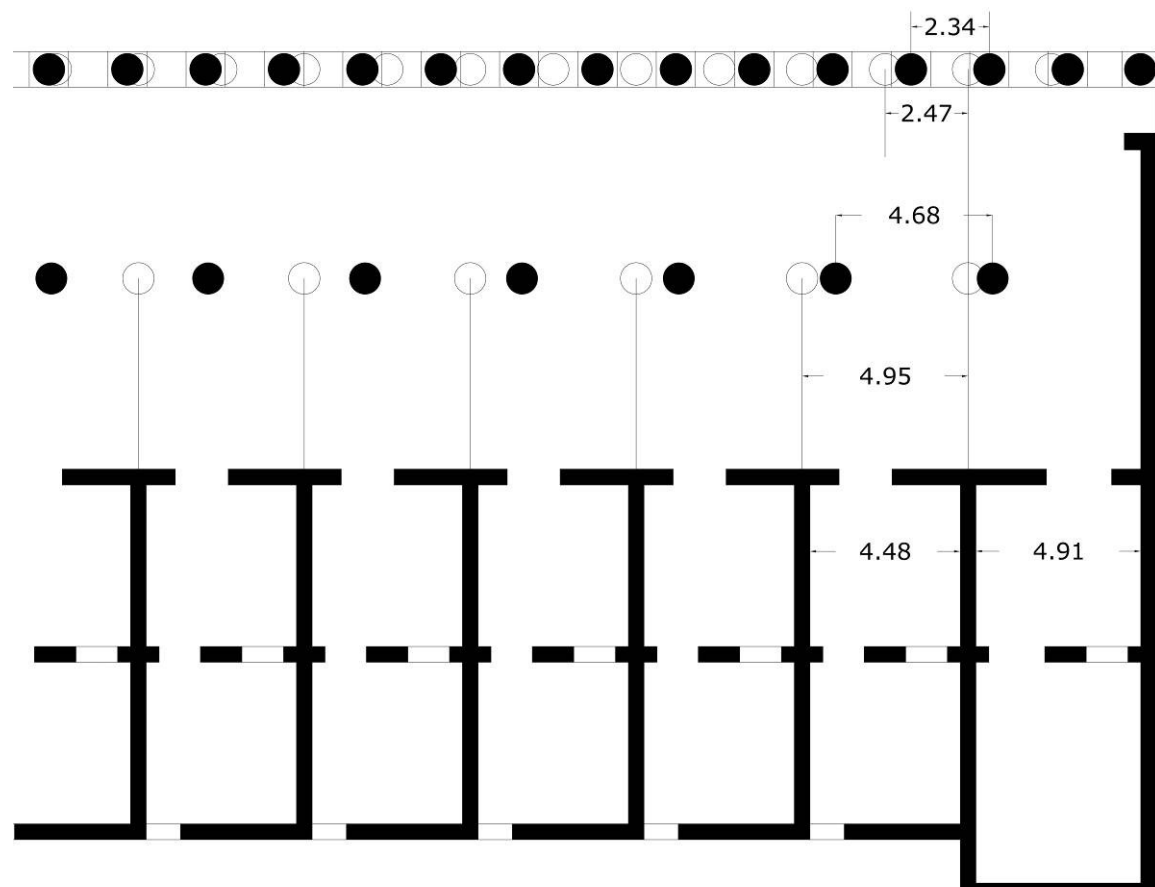

Fig. 21. Interaxial dimensions of the exterior and interior colonnade vis a vis the backrooms with dimensions as built and theoretical units based on lining up the columns with the walls of the backrooms.

¹⁰⁰ Broneer (1954, 24) made similar calculations based on a length of 164.47 m.

A simpler process would have been to make the number of rooms thirty-five, with the room divisions following the internal colonnade east to west. If there were thirty-five rooms, the interior width of each room would have been 4.35 m., only 0.13 m. shorter. It is difficult to see a reason why the builders opted for thirty-three instead of thirty-four rooms, unless there was a need for exactly that number and size. In stoas with backrooms, however, more often than not the rooms do not line up with the colonnade.¹⁰¹ In many stoas, though, rooms are not so uniform in size, as they are in the South Stoa.¹⁰²

The front and back rooms at the east end of the building are 10 cm. wider than the rest of the rooms at the level of the toichobate. The foundations are irregular along the east wall in that the blocks below the euthynteria project toward the inside so that the euthynteria course hangs over the edge on the outside, which might reflect the 10 cm. discrepancy, since the line of the wall from the euthynteria up is aligned from front to back. **Fig. 22**

¹⁰¹ See discussion of stoas with rooms below.

¹⁰² On the development of stoas with two colonnades and rooms at the back, see Martin 1951, 454-458. Also see below.

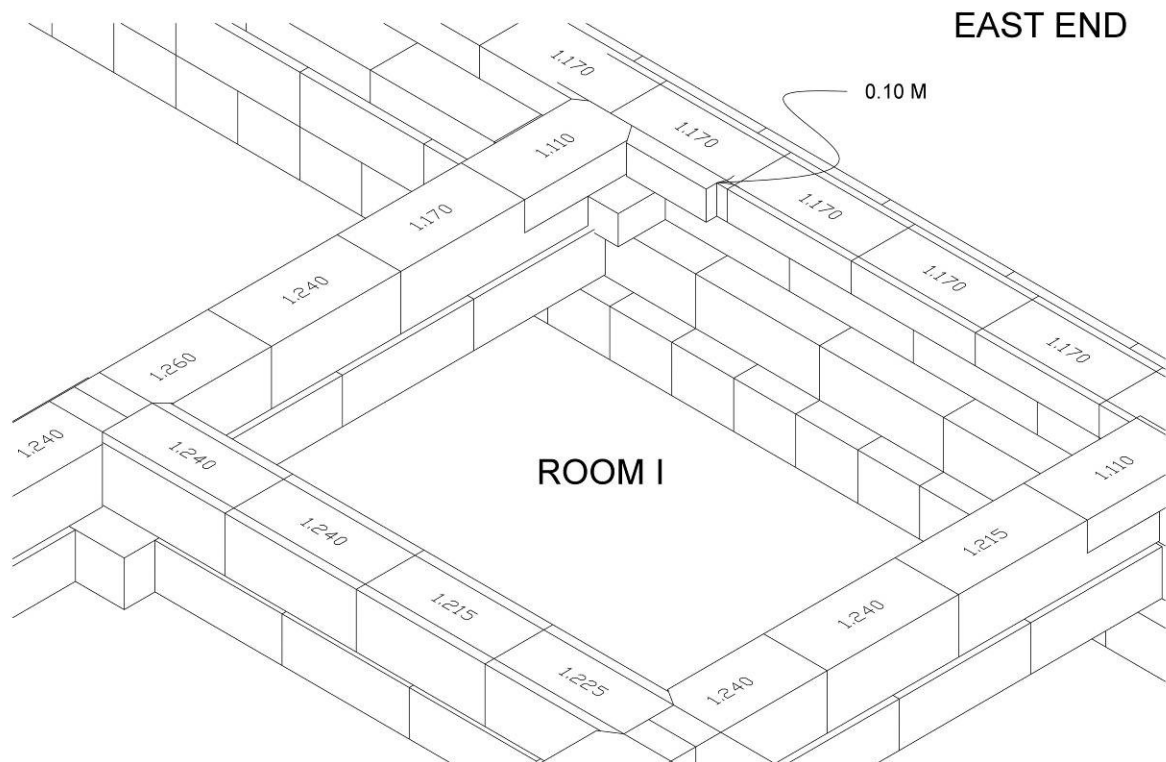

Fig. 22. Foundations for Room I at east end of stoa. The 10 cm. addition to the width of room one aligns the toichobate with the front half of the building. Note also block size changes for the foundations of the backrooms.

The discrepancy of measurements at the two ends of the building may reflect the way in which the colonnade and the backrooms were constructed. If the two parts of the building were separate projects running concurrently, then any difference in measurements could be accounted for as the construction reached the end if construction started at one end and proceeded to the other end. In some cases, at least in temple architecture, the colonnades are laid from both ends and meet in the middle.¹⁰³ In the South Stoa, a process of laying the foundation blocks from one end to the other end would account for the discrepancy in the backrooms. The extensive length of

¹⁰³ The fourth century Temple of Zeus at Nemea is an example (see discussion of the frieze below).

the building might preclude the possibility of working from both ends toward the middle, since it may have been thought that any creeping error over such a long distance would be almost impossible to correct in the middle of the building. It is probable that construction began either in the middle, working toward both ends, or from one end of the stoa to the other. Since the adjustment of the foundations appears at the east end, it seems more likely that the work began at the west end of the foundations and progressed toward the east end. In any case, the 10 cm. discrepancy in the width of the block of rooms was possibly merely the result of adjusting the overall length of the room dimensions to the front foundations, which must have held precedence from the beginning of construction.

“Masons Marks”

A total of sixty-three blocks with mason’s marks were compiled by Broneer.¹⁰⁴ No additional marks have been found. The marks occur on some of the lower foundation blocks, while most are on the sides of the stylobate, toichobate and krepidoma blocks. There are thirteen types of marks broken down by Broneer into five groups and of these five groups, four groups seem to belong to distinct places in the building.¹⁰⁵ **Fig. 23** No paint has been observed inside the cuttings.

¹⁰⁴ 1954, 26.

¹⁰⁵ These marks were documented by Broneer (1954 26-28, Fig. 5). I know of no other building for which a relationship has been attested between marks and position in the construction of the building with the possible exception of the fourth century temple at Megara Hyblaea (Vallet and F. Villard 1966, 9-10, Pls. 8 and 9). This is in distinction to later Roman examples that testify to marks for repositioning blocks (e.g. the Temple of Ares in the Athenian Agora). Examples of buildings in the Peloponnesos with documented mason’s marks include The Temple of Apollo Bassitas (Cooper 1996, 354ff); the Classical Temple and the South Stoa at the Argive Heraion; the Tholos at Epidauros; the Temple at Gortys in Arkadia (Martin

Group One, Stylobate blocks

1. Three vertical bars topped by a horizontal bar. The left vertical bar extends above the horizontal bar. Occurs one time below the second column from the west end.
2. Psi (?). Occurs two times on the rear of the stylobate at the east end. One falls directly behind a column center.

Group Two, Rear edge of the first step on the north façade

- 3b. Delta with a stroke. Occurs five times at the west end.
4. Upsilon (?). Occurs three times, in front of shops XXIV and XXV, right side up. One time opposite shop II, upside down. One on second block from east corner upside down.
- 5a. Nu. East end.
- 5b. Nu reversed. East end.
6. Alpha lambda. East end. Upside down.

For the second group, fourteen out of twenty-one blocks have marks. Broneer notes that the remaining seven without marks on the rear side could have been marked on the front side, which would have been removed in the final dressing of the front of the blocks.

1965, Pl.xxii:5). For mason's marks in general, see Martin 1965, 222-231; Orlandos 1968, 84. Also see the discussion of mason's marks in Guarducci 1974, 377-393, where she divides marks by type. The distinction between marks by contractors versus those by masons is the crucial point that makes them more difficult to decipher.

Group Three, Toichobate for front wall of backrooms

7a. Cross (Chi?) with an alpha.

7b. Alpha with cross (Chi?). Both 7a. and 7b occur at points along the toichobate six times, four on the front side and two on the rear side of the block.

8. Mu, Nu, Theta combination. Occurs four times at west end in front of rooms XXVII, XXVIII, XXXII.

Group Four, Step course, east foundations (once in course three)

9a. Alpha, Nu, Epsilon ligature.

9b. Nu, Epsilon ligature.

9c. Nu, Epsilon ligature.

Occurs two times on the rear of the step course of the east foundations, once on course three, in room XXXII.

Group Five, Various places in the building according to Broneer¹⁰⁶

10. Three vertical strokes with a horizontal stroke across the middle. Occurs eight times.

11. Cross (Chi?). Occurs eight times.

12a. Three vertical strokes with a horizontal bar on top. Occurs six times.

12b. Three vertical strokes with a horizontal bar on top that extends to the right of the third bar. Occurs one time.

12c. Three vertical strokes. Occurs one time.

¹⁰⁶ These have not been located by me and their find spots are not located by Broneer.

13. Two converging strokes with a cross stroke. Occurs four times.¹⁰⁷

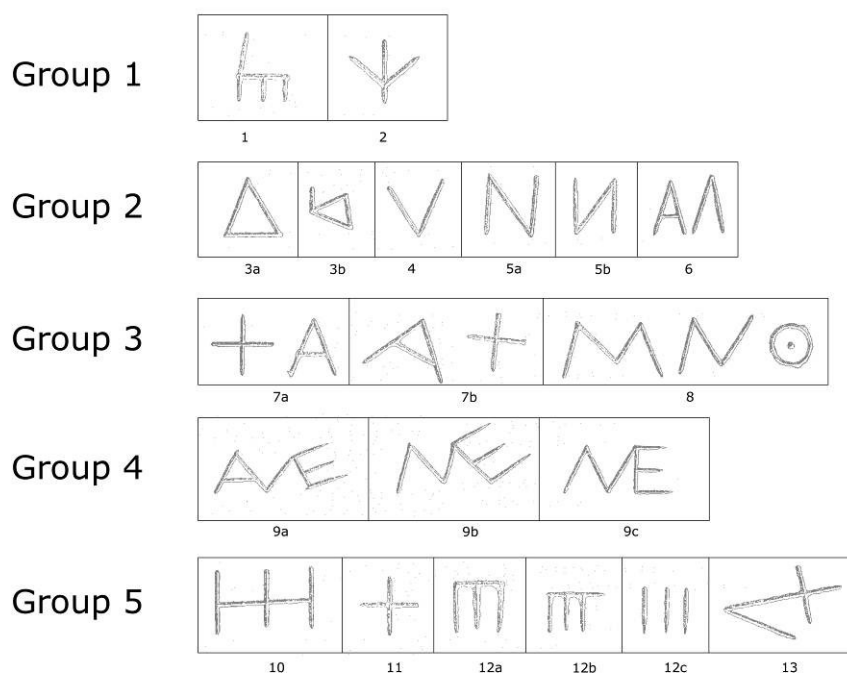

Fig. 23. Masons marks by distribution and type. After Broneer, 1954, Fig. 5.

Since, except for group five, the distribution of masons marks does seem to suggest that groupings exist within specific locations in the building, it is possible that the marks on the South Stoa represent evidence of contractors responsible for supplying and/or setting the blocks in various parts of the building. Alternatively, the marks have been interpreted as designating courses for the blocks.¹⁰⁸ Epigraphical evidence from Delphi and Epidauros would seem to suggest that the marks are connected to contractors

¹⁰⁷ Group Five no. 13. c.f. the **F** on a block from the foundations of the Hellenistic diazoma of the theater at Corinth (see Stillwell 1952, 22, Fig. 13).

¹⁰⁸ Broneer 1954, 28.

responsible for supplying blocks.¹⁰⁹ If the marks are for contractors, then it may not be a question of marks indicating position in the building as much as contractors responsible for specific sections of the building. It follows that if the marks on the toichobate of the front wall of the rooms are specific to that location, they may represent contractors engaged only for that section of the building.

A separation of material and labor for different parts of the stoa is supported by the fact that the dimensioning of blocks was not the same in all locations of the building. The blocks in the back half of the stoa were cut to different specifications dictated by an independent dimensioning system based on room divisions within the overall length. These dimensions were calculated separately from the modular spacing used in the front half of the building. This would be one reason why a separate contractor might be responsible for blocks in just this section of the stoa. It is also possible that due to the extensive length of the building, the contractors were given different sections, as reflected within Group two. Group five, however, shows that some marks could occur anywhere within the foundations of the building, indicating some contractors might supply blocks to be used in various locations.¹¹⁰

¹⁰⁹ At Delphi on the 4th century Temple of Apollo and the “monument en calcaire gris”, a relationship has been attested between marks and contractors listed in the building accounts, who were responsible for quarrying, transport and placement of blocks. For Delphi see Amandry 1981, 683, 686, 707; 1983, 854 and Bousquet 1989, 83-129. At Epidaurus, the inscriptions indicate that each section was contracted out for a price. Contractors’ responsibilities include employing men to quarry the supply of stone, or to employ masons to construct columns, for example (Burford 1969, 57).

¹¹⁰ Broneer (1954, 28) reached a similar conclusion regarding group five, but noted that numbers 10-13 of group five may indicate course designations. For masons marks on the Temple of Zeus at Nemea which are suggestive of block placement see Hill and Williams 1966, 43.

Chapter 3

Krepidoma

The krepidoma consists of two steps, of which the top step is the stylobate on the north front of the building. Both steps have a continuous triple banded, or recessed, compound molding at the lower, outer edge of the riser.¹¹¹ **Fig. 132** The blocks of the first, lower, step are ca. 1.17 m. in length, 1.40 m. in width originally and 0.27 m. in height.¹¹² The tread of the step is 0.325 m. on the front north side. Along the two lateral ends of the building the tread has a slightly greater projection of 0.355 m.

Counting from both ends of the building, the tenth block of the course below the stylobate has a setting line, mid length, on top of the block, perpendicular to and just at the south edge to mark the position of the stylobate block above. **Fig. 24**

¹¹¹ This compound molding is a feature common to Peloponnesian architecture of the 4th century B.C., seen as early as the end of the 5th century in the temples of Hera at the Argive Heraion and Apollo at Bassai. See Pfaff 2003, 76, 175 and Fig. 122.

¹¹² The depth was cut back to 1.05 m. in the Roman period, when a new drain was installed in front of the stoa. This will be dealt with in the publication of the Roman phases.

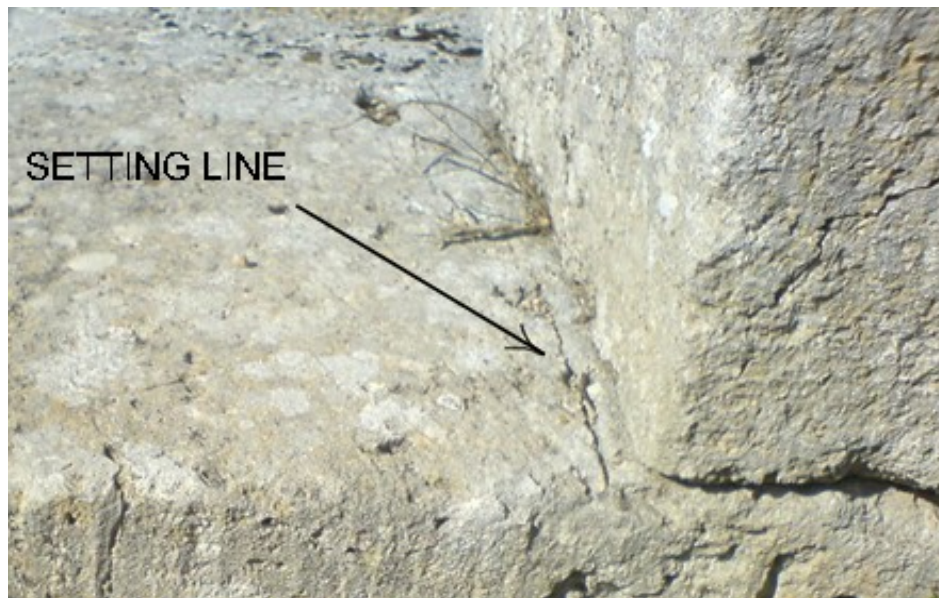

Fig. 24. Setting line on Krepidoma at east end.

This is unusual in that there do not appear to be any other setting lines on the other krepidoma blocks, of which there are a fair number. The distance is the same at both ends of the building from the inside edge of the first stylobate block to the setting line and amounts to 10.42 m. Between the inside corner of the foundations and the block with the setting line, there is one half block, which amounts to 0.585 m., seven full blocks with a normal length of 1.17 m., then one block 1.105 m., while the block that meets the west end is 0.54 m. in length to the edge of the side toichobate.¹¹³ **Fig. 25**

¹¹³ At the back of the stoa the eastern most block of rooms is 10 cm. wider than the corresponding rooms at the west end, but this did not affect the front foundations at all. One might have expected the east end at the front to reflect this additional 10 cm. difference, but it is not the case, since the rooms were divided into the overall length after the fact. Broneer (1954, 20) noted that the width of the first room at the east end is 10 cm. wider than that of the other rooms, but he did not discuss whether or not this would have affected the front of the building and he does not discuss the setting lines on the front krepidoma.

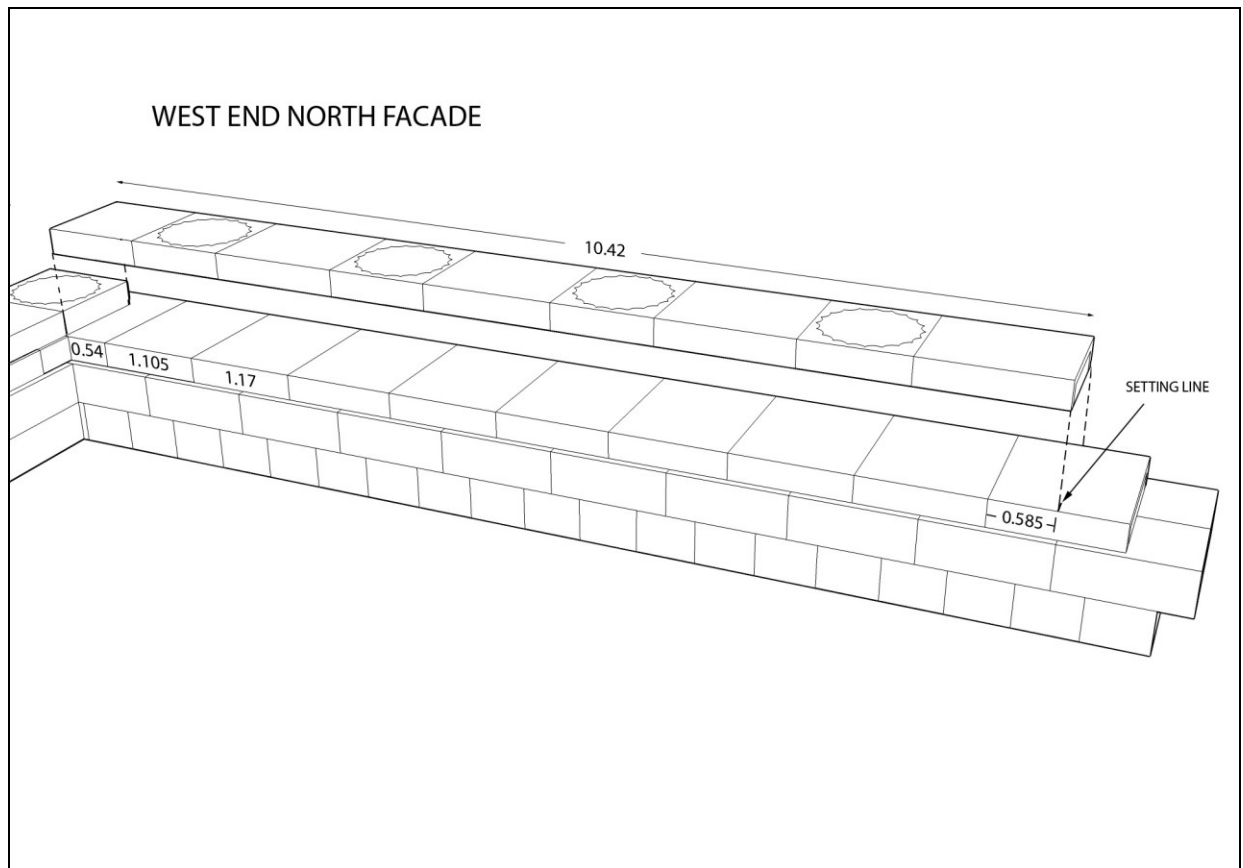

Fig. 25. West end of North façade showing setting line for stylobate course at the end.

A plausible reason for the setting lines just at these points on the krepidoma is that they served to make sure the corner contraction at the two ends of the building was correctly handled at stylobate level and the stylobate blocks in between were correctly positioned to take the regular spacing of the colonnade. This would seem to indicate that the stylobate was built in three sections so that the two ends would work out correctly with the normal blocks in the middle. With the setting lines fixed, the irregular blocks of the corner could be laid while the middle section was being laid, without worry that the ends would cause a problem.

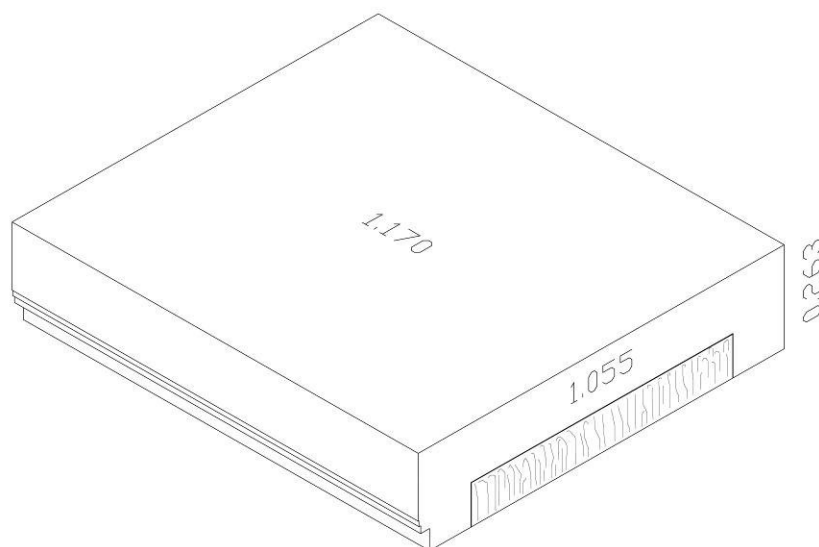

Fig. 26. Isometric view of a proposed normal stylobate block from north façade.

The normal length for the krepidoma blocks of the lower step, or second course down, is 1.17 m. This applies to all the krepidoma blocks of the second course that exist, with the exception of the last two blocks at both ends of the building as shown above. The length of 1.17 m. for this course is a standard length and is half the interaxial distance (2.34 m.). The blocks have anathyrosis on the joining ends.

Stylobate of Front Colonnade

Only one complete stylobate block exists. This is the first stylobate block at the west end of the building. It measures 1.08 m. in length, 1.055 m. in width, and 0.263 m. in height.¹¹⁴ The normal stylobate block is designed to

¹¹⁴ The first stylobate block at the east end of the building is a Roman replacement.

fit into the spacing of the interaxial distance of the colonnade, which if divided evenly would make each block almost exactly 1.170 m. in length, 1.055 m. in depth and 0.263-0.270m. in height, that is the stylobate blocks would be exactly the same as the second course down. **Fig. 26** In fact, however, the preserved evidence suggests that the stylobate blocks were not made to this modular length, but were spaced in alternating lengths that together added up to 2.340 m.

At the west end of the building the first stylobate block is preserved to its full length of 1.08 m. The second stylobate block at this end is damaged and accurate measurement of its length is not attainable, but the third stylobate block is preserved in its original position on its left edge. Therefore the distance between the first and third blocks, as preserved, provides the length of the second block which is ca. 1.04-1.05 m. The third stylobate block, although damaged, is ca. 1.02 m. in length.¹¹⁵ The fourth stylobate block is broken but the length of the two sections together works out to be ca. 1.30-1.32 m. If the correct length is 1.32 m., the combined total of the third and fourth blocks is 2.34 m., which is the normal interaxial distance. This would suggest that the normal blocks of the stylobate measure ca. 1.02 m. and ca. 1.32 m. respectively, so that the columns would rest on blocks 1.02 m. in length and the space between would be filled with a block 1.32 m. in length.¹¹⁶

¹¹⁵ Broneer (1954, 30) seems to indicate that only the first and last blocks reflect the corner contraction and thus they are 1.08 m. in length instead of 1.17 m. The blocks of the euthyteria and krepidoma, however, already indicate that the second stylobate block reflected the contraction as well, if the stylobate blocks are to line up on center with the blocks below.

¹¹⁶ Broneer (1954, 30) suggests that, except for the last block at each end, the stylobate blocks were 1.17 m. in length. I know of no local parallel for alternating block lengths of the stylobate. The North Stoa on the Agora at Assos employs similar alternating lengths for the stylobate of the first level (See **Fig. 103** below). A slightly different situation can be seen in Pergamon in the later Hellenistic period, where the

One question would be why the builders would go to the trouble of alternating the lengths of the blocks, since this would add to the labor time and means that blocks underneath would not line up as nicely.

The first and second stylobate blocks at both ends must take into account angle contraction.¹¹⁷ If the amount of contraction is one half the triglyph width the contraction would be 0.225 m. since the triglyph width at the corner is 0.45 m. as reconstructed from the corner mutule.¹¹⁸ This amount subtracted from the normal interaxial distance of 2.34 m. leaves 2.115 m. for the contracted inter-axial distance. **Fig. 27** A slightly larger triglyph width of 0.468 yields 2.106.¹¹⁹ **Fig. 28a** and **b** show the stylobate reconstructed with alternating lengths for the stylobate blocks, on top of the state plan. With this spacing, the corner contraction reduces the first interaxial distance to 2.09-2.095 m.

stylobates of the temple of Athena and the stoa of Athena have alternating lengths which are longer under the column and shorter between (Altertümer von Pergamon II, Pls. XII and XXI respectively). The issue of alternating stylobate block lengths versus regularized lengths deserves more attention.

¹¹⁷ See Coulton 1974, p. 73, where he states that Peloponnesian temples of the 4th century normally have an architrave thickness twice the width of the triglyph so that angle contraction is reduced to a simple formula of $\frac{1}{2}$ the triglyph width. This is the formula that Vitruvius gives (De Arch. iv. 3.2).

¹¹⁸ See the discussion of architraves and frieze course below for argumentation of this.

¹¹⁹ If the second and third stylobate blocks were both 1.08 m. in length respectively, then the interaxial distance would be 2.16 m., which is the length given by Broneer (1954, 21, Fig. 3).

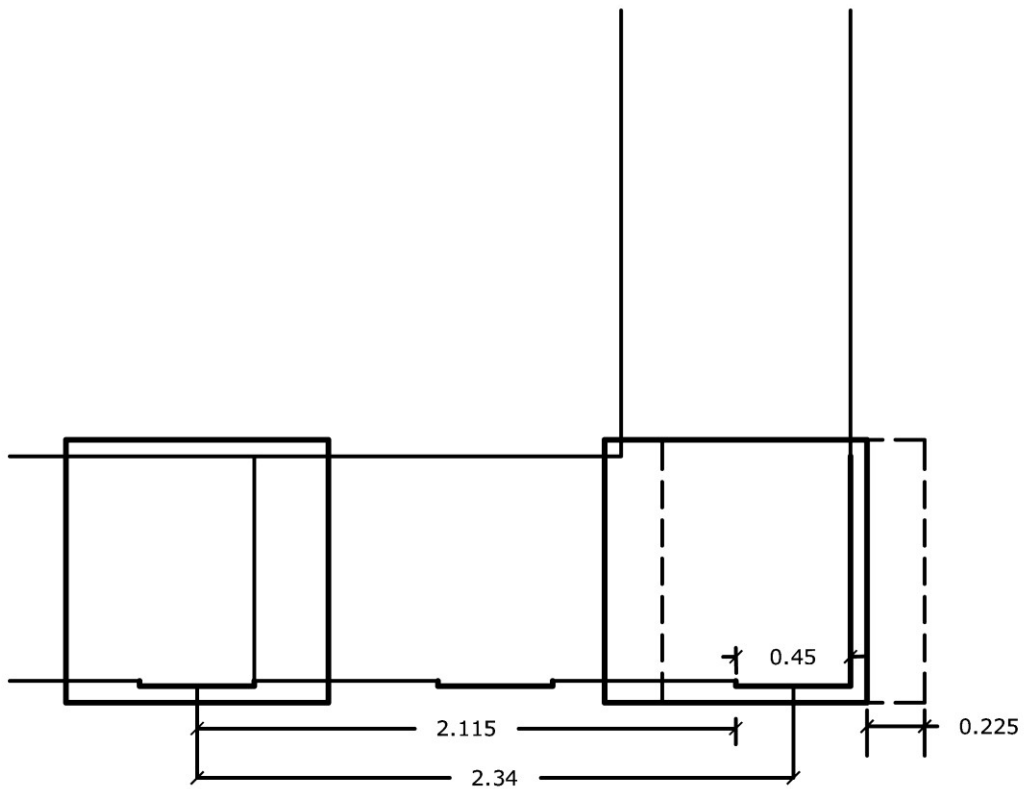
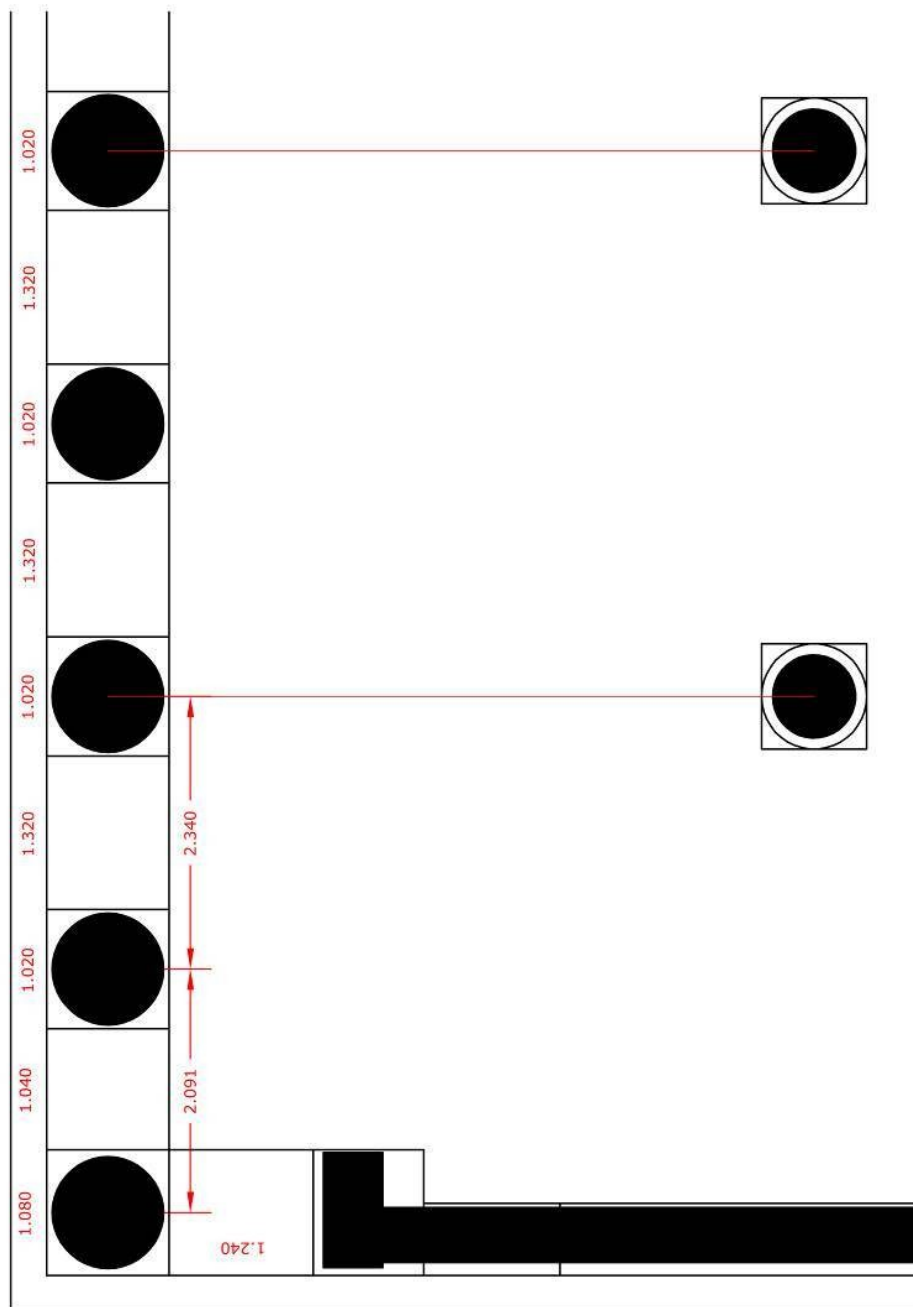

Fig. 27. Corner contraction shown at the west end. Amount of contraction equals 0.225 m. ($1/2$ the triglyph width), leaving 2.115 m. for the interaxial distance at the corner.

b.



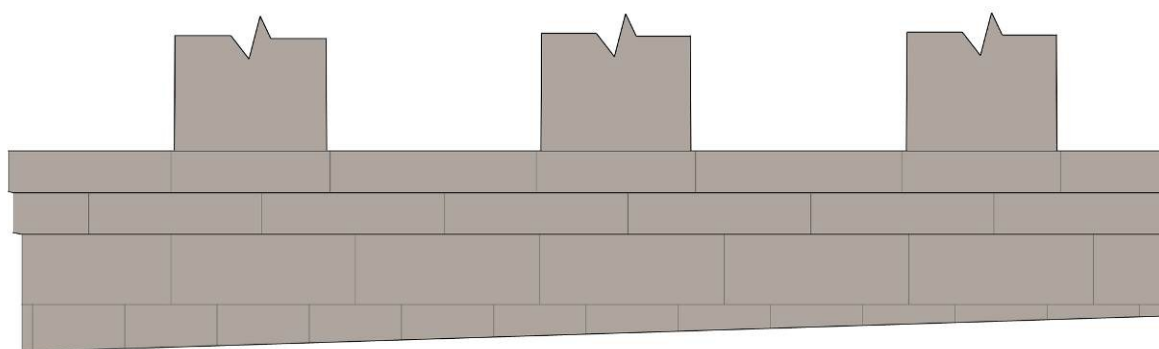

Fig. 29. Block alignment visible inside west corner, with proposed alternating stylobate block lengths.

Alternating stylobate block lengths would be an attractive option for the dimensioning of the stylobate blocks as it would underscore the column spacing and, by reducing the length to 1.02 m., it allows the stylobate block beneath the column to act as a kind of plinth. It means, however, that the stylobate blocks would not line up precisely with the middle of the joints of the krepidoma course below. **Fig. 29** There are also three partially preserved blocks in the stylobate course at the east end of the building, which argue against this spacing. One block is 1.17 m. in length and two others are slightly longer than 1.02 m. The full lengths of the shorter blocks are not preserved and it is not entirely clear that these three blocks are original to the building or whether they might be later replacements. The block which is 1.17 m. in length could, in fact, be a krepidoma block from the course below the stylobate, reused at stylobate level during a later refurbishment. It is possible, however, that based on this evidence the normal stylobate blocks are 1.17 m.

in length, while the first and second at each end are 1.08 m. and 1.04 m. respectively and the third block would be 1.02 m. in length.

Broneer states that the total length of the building is 164.47 m. on the stylobate and that the blocks were 1.17 m. (1.696 m.) in length except for the last blocks at both ends, which were 1.08 m. in length, and the second block which must be reduced to ca. 1.04 m. His calculation for the total length, however, is incorrect.¹²⁰ The total length of the stoa on the stylobate is actually 164.38 m.

If calculated based on total length of the stylobate, the normal interaxial distance would be 2.34 m. ($164.38 - [2 \times 0.54 + 2 \times 2.09] / 68 = 2.34$) and the theoretical stylobate block length would be 1.17 m. An overriding problem with this method of analysis is that it assumes linear consistency of block lengths based on fitting the blocks into the overall distance. A check on the dimensions derived this way can be achieved against the setting line between the tenth and eleventh stylobate blocks at both ends of the building, showing that the theoretical stylobate block length of 1.1689 m. does not work with the setting line length. The length from the edge of the stylobate to the setting line is 10.42 m. at the west end. The stylobate block theoretical lengths plus the first two blocks would equal 11.47 [$1.08 + 1.04 + (1.1689 \times 8)$] and therefore

¹²⁰ Broneer's calculations for the stylobate length appear to be incorrect (1954, 33). If the length were 164.47 m. and the two end blocks were 1.08 m., the axial distance end to end would not be 163.41 m. as he calculates, but would be 163.39 m. The theoretical block measurement of 1.1696 m. (Broneer *ibid*, 20) from end to end inside the two end blocks would be 0.2648 m. too long, but Broneer handles this by reducing the contraction on the corners to 2.16 m. That is, it is implied by Broneer that the second stylobate block at both ends was reduced from the theoretical length of 1.1696 m. to 1.0376 m. In any case the actual length of the stylobate, shot by the author with a total station on two separate occasions, is 164.38 m. Curiously, this is the length shown in Broneer's Plan X, a. I thank C. K. Williams and James Herbst for help with the surveying of the stoa length.

would not work well with the setting line without a block of longer length in the third position. **Fig. 30**

The previous analysis of the front stylobate illustrates the limitations imposed by the poor state of preservation. Both versions for the lengths of the stylobate are based in part on theoretical calculations tied to the frieze blocks and subsequent interaxial distances of the columns, discussed in more detail in their relevant sections below. If a frieze unit of 2.34 m. is imposed, it is clear that regular block lengths of 1.17 m. will work with the rhythm of the frieze, except at the ends where corner contraction is present.

Therefore, at both ends of the building the first block length is 1.08 m., the second is 1.04 m., after which it would be theoretically possible that the stylobate block lengths alternate between ca. 1.02 m. and ca. 1.32 m. It is unlikely that the lengths were ca. 1.17 m. since this length would only work with the setting line if the third block were larger.

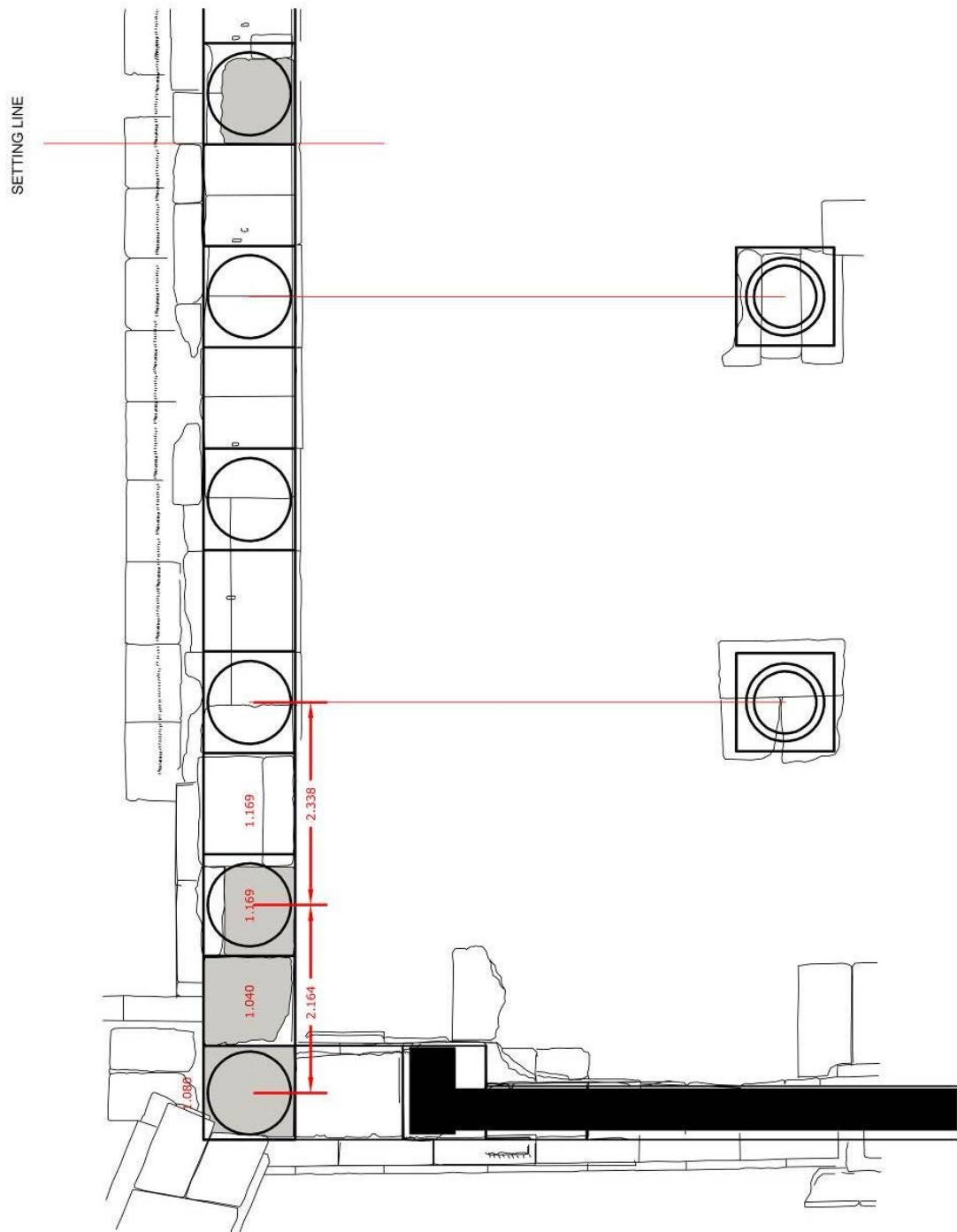

Fig. 30. West end state plan showing overlay of stylobate blocks with theoretical length of 1.169 m. Original stylobate blocks in gray.

Toichobate

Where the stylobate turns the corner at both ends of the building the toichobate continues back to the wall anta with the same width as the length of the stylobate block on the corner (1.08 m.). The second block on the west side is 1.24 m. in length and 1.08 m. wide. The third toichobate block is 0.97 m. in length, ca. 1.08 m. in width and runs under the anta. **Fig. 31**

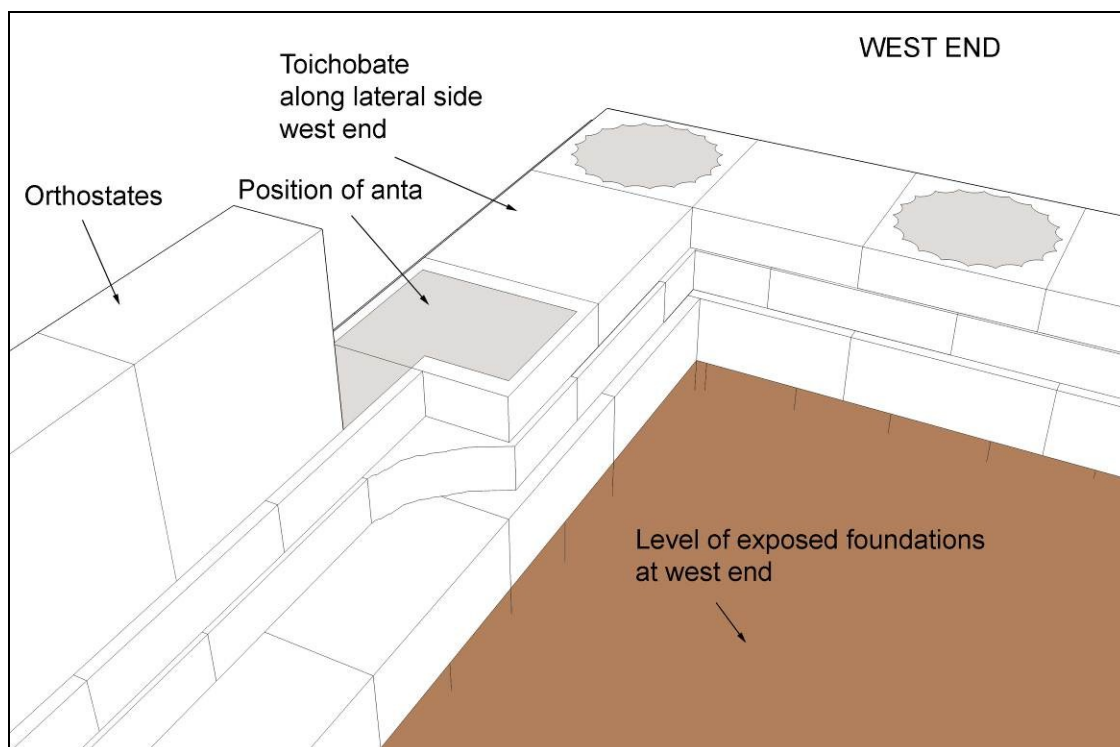

Fig. 31. Perspective of interior corner of northwest end showing foundations and toichobate where it turns the corner and begins running under the west wall.

The “normal” toichobate blocks for the east, west and south walls of the stoa measure ca. 1.17 m. in length, 0.60 m. in width and 0.27 m. in height, with some slight variations in dimensions. The dimensions of the toichobate blocks for the walls of the back rooms differ from the front of the building, determined as they are by the division of rooms within the overall length of the building. Here the blocks measure ca. 1.24 m., with occasional blocks of 1.17

m. also inserted. The dimensions of the N-S walls and E-W walls of the rooms are based on a different system than the outer foundations, because the blocks of the back rooms had to accommodate 33 room units, each roughly five meters square. The toichobate blocks of the rooms bond either between two blocks at the front and back walls or at the midpoint of blocks in the east and west walls, so the bonding is calculated to take into consideration the different dimensions of the room foundations and the outer wall foundations.

Fig. 32

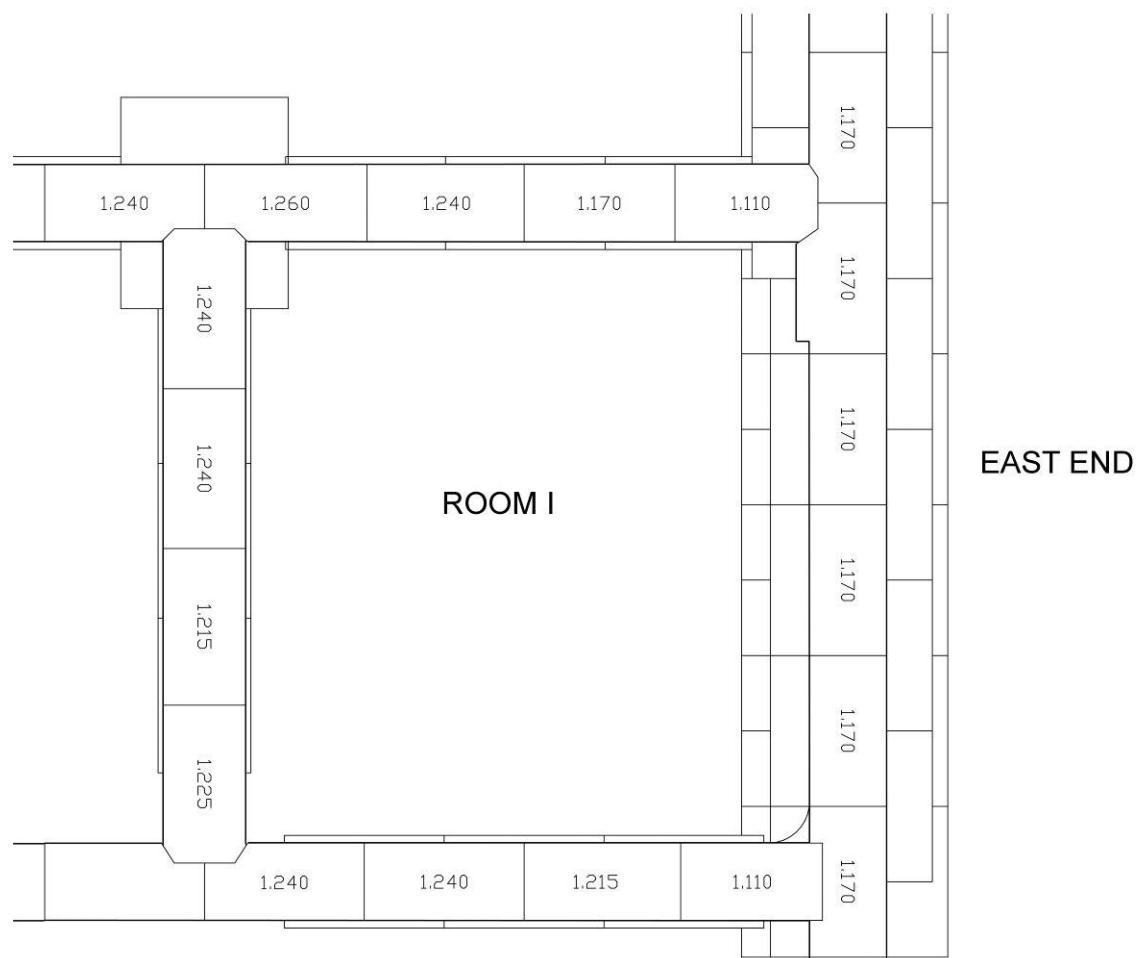

Fig. 32. Toichobate bonding of Room I, east end.

Along the west wall on the interior, the toichobate blocks, as well as the euthynteria below, were trimmed back to accommodate the stair foundation.

The east toichobate blocks are also trimmed back to some extent, but it is unknown whether or not the east wall foundations also accommodated foundations for a staircase as this section of the stoa has never been investigated below toichobate level.¹²¹

¹²¹ It would be necessary to excavate the eastern limits inside the east wall of the stoa in order to see whether or not a staircase existed at the east end of the building.

Chapter 4

Exterior Doric Columns

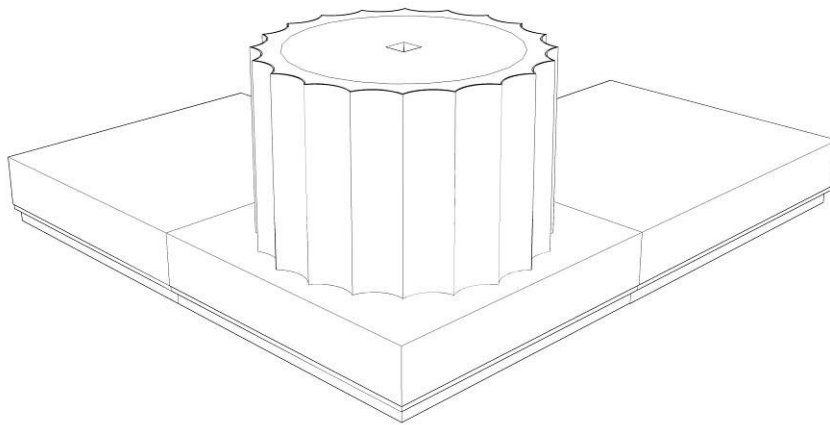

Fig. 33. Perspective view of Doric column drum Northwest corner.

Shafts

The exterior Doric columns are made up of a series of drums each with twenty flutes. Only the lowest drum at the west end of the building is preserved *in situ*. **Fig. 33** Thirty-seven South Stoa column drums have been located and recorded by Broneer. This accounts for approximately five to six percent of the total number, if each column had between nine to ten drums. The total height of the colonnade is unknown for certain, but an approximate height can be ascertained from a number of inferences, discussed below.

The lower diameter inside the flutes is 0.906 m. and the estimated diameter on the arrises is ca. 0.96 m. The drums have empolia in all top and bottom surfaces except the lowest bottom surface.¹²² The columns are spaced so that they are centered on every other stylobate block, with an interaxial distance of 2.34 m. as shown in the discussion of the krepidoma and based on other evidence, especially that of the frieze block lengths, discussed below. The columns exhibit corner contraction, evidenced by the lengths of the first, second and third stylobate blocks at west end of the building. If the building followed the Vitruvian method for contraction, the amount of contraction should work out to be one half the triglyph width since the frieze thickness is almost exactly twice the width of the triglyph, but this seems not to have been applied. The interaxial distance between the first and second columns at both ends of the building would be $2.34 - (0.45/2) = 2.115$ m. By contracting the column spacing the frieze does not have to change dimensions at all. The actual spacing seems to be slightly less (2.095 m.). (See **Fig. 27** and **Fig. 28** and discussion of stylobate above).

Determining the height of the columns is made difficult due to the small number of drums that exists.¹²³ Nevertheless, several methods are explored here that may provide some indication of the column height: determination of

¹²² See Pfaff 2003, 91, fn. 23, for reference to the fact that beginning in the 4th century B.C., it is common to have poloi and empolia in the bottom surface of the lowest drum. For example in the tholos at Epidauros (Roux 1961, Fig. 29); at Delphi in the tholos (Charbonneau and Gottlob 1925, Pls. II, IV) and "Temple en calcaire" (Michaud 1977, Figs. 41-43); the Temple of Zeus at Nemea (Hill and Williams 1966, 5); the Temple of Zeus at Stratos (Courby and Picard 1924, Figs. 7-8).

¹²³ Broneer's measurements, as recorded in the notebooks, are to the millimeter. After re-checking several drums it was determined that the heights and diameters were quite accurate and a decision was made to use the measurements as recorded in the notebooks. Any deviations would amount to millimetric discrepancies and the drum surfaces have only degraded in the intervening years, so that any error would not be resolved.

column taper from known bottom and top diameters, generation of average column drum heights and overall column height, calculation of the height of the columns based on the height of the ridge and slope of the roof.

One way to determine approximately how many drums per column are necessary is to analyze the taper of the drums against the overall column taper, given that the top and bottom diameters of the column are known. The lower diameter of the column is 0.96 m. on the arrises. Since the arrises are mostly damaged, this measurement has to be reconstructed, hence millimeters are excluded. The lower diameter of the column capital on the arrises is 0.794, making the total taper ca. 0.16-0.17 m.

Broadly speaking, there are two rates of taper evident (see tables below where upper and lower diameters on all the drums are tabulated). For the lower column drums the degree of taper per drum is ca. 0.01 m. The upper drums appear to have a slight increase in taper amounting to 0.02 m. per drum, but in no case does the taper appear to increase beyond 0.02 m. Two possible solutions would be ten drums (4 x 0.01 m. taper + 6 x 0.02 m. taper = 0.16 m. taper), or nine drums in total, if the heights of the drums are calculated slightly differently, as discussed below. If the rate of diminution truly does not increase beyond 0.02 m. per drum, in no case could there be fewer than nine drums.¹²⁴

The average height of extant drums measures 0.62 m., but this is only a rough estimation given the small percentage of drums. The tallest drum

¹²⁴ Broneer calculated a height for the Doric columns based on the maximum height that the interior Ionic column could reach without stretching the column beyond "normal" proportions in his restoration. His height for the Doric columns, 5.70 m., is calculated using eight average size drums of 0.595 m. plus one short drum of 0.55 m. and a capital (1954, 32).

measures 0.706 m. in height. There are only two drums with top diameters that could go at the top of the shaft and both are shorter than average, with heights of 0.552 m. and 0.565 m., so it is possible that the uppermost drums were slightly shorter than those of the rest of the shaft.¹²⁵ If all the drums are averaged, except the outliers (those which are extremes on the high side), then nine normal drums (0.62 m.) plus one short drum (0.56 m.) plus a capital of 0.40 m. (actual 0.395) gives a column height of 6.54 m. making the diameter to height ratio 1:6.8 (1:6.8125).¹²⁶ This is slightly less than the 1:7 ratio suggested by Vitruvius and is close to contemporary proportions.¹²⁷

If ten drums were used, the total height would be 6.595 m. (10 x 0.62 m. + 0.395 m.), or 6.87 times the lower diameter. If only nine drums were used per column, the total height would be 5.98 m. (9 times 0.62 m. (or [7 x 0.62] + [0.706 + 0.552] equals 5.58 m., plus a capital of 0.40 [actual 0.395 m.] equals 5.98 m.), or 6.23 times the lower diameter.

If, however, it is possible to separate the drums into groups by position in the column, this would provide a more accurate starting point to calculate the averages of the drums. In fact, the diameters can be divided into ten positions based on upper and lower extremes. This coincides with one of the possible solutions for the number of drums needed given a taper factor of between 1 and 2 cm. per drum. As can be seen in **Table 1**, five of the extant

¹²⁵ Broneer suggested this (1954, 32).

¹²⁶ If the shorter drum size is used as a pair with the larger size of 0.706 m., together they are just slightly taller than two average size drums of 0.62 m. (0.62 m. x 2 = 1.24 m.; 0.552 m. + 0.706 m. = 1.258 m.), indicating that perhaps the tallest and lowest drums, which would otherwise skew the average, should be left out since taken together they can be understood as equaling two normal size drums. Therefore, it is assumed to be better to calculate the height using only the average height per drum of 0.62 m. plus the capital.

¹²⁷ Vitruvius on 1:7 ratio. Roughly contemporary ratios are on the order of between 1:6 and 1:7. Temple of Zeus at Nemea (ca. 320 B.C.), 1:6.3421. Stoa of Attalos (mid 2nd c. B.C.), 1:7.0566.

drums provide no information for lower or upper diameters, so they have been omitted from the series. One of these represents the tallest recorded height (0.706 m.). By taking measurements of the diameters and heights of all the drums available, it is possible to divide the drums into groups based on position and find averages for the heights of each position. In this way an approximate height can be determined.

Table 1. Raw data from Doric Column Drums ordered by lower diameters. Values Expressed In Meters. Thirty-seven total column drums represented. Measurements for diameter taken inside flutes.

Height	Lower diam	Upper diam	Dimin	Empolia
0.552	0.762	0.755	0.007	2
0.580	0.763	0.752	0.011	
0.565	0.765	0.750	0.015	2
0.636	0.784	0.765	0.019	2
0.578	0.790	0.770	0.020	2
0.601	0.794	0.776	0.018	
0.606	0.808	0.796	0.012	2
0.650	0.811	0.788	0.023	2
0.563	0.813	0.790	0.023	2
0.595	0.822	0.806	0.016	2
0.595	0.824	0.814	0.010	
0.627	0.831	0.813	0.018	2
0.607	0.832	0.810	0.022	2
0.590	0.833	0.815	0.018	
0.623	0.834	0.815	0.019	2
0.590	0.835	0.820	0.015	2
0.608	0.835	0.820	0.015	
0.645	0.840	0.825	0.015	2
0.610	0.843	0.833	0.010	1
0.612	0.845	0.835	0.010	2
0.610	0.857	0.845	0.012	2
0.630	0.858	0.847	0.011	2
0.620	0.865	0.848	0.017	
0.630	0.873	0.860	0.013	
0.620	0.875	0.866	0.009	
0.616	0.857	0.846	0.011	2
0.614	0.875	0.867	0.008	2
0.640	0.887	0.877	0.010	2
0.641	0.895	0.888	0.007	
0.637	0.897	0.887	0.010	
0.601	0.906	0.897	0.009	
0.608				2
0.610				2
0.634				2
0.706				2
0.660				

Table 2. Averages: Calculated based on hypothetical groupings of diameters in elevation with averages. Values Expressed in Meters.

Height	Lower Diam.	Upper Diam.	Dimin.	Empolia
0.552	0.762	0.755	0.007	2
0.580	0.763	0.752	0.011	
0.565	0.765	0.750	0.015	2
0.5657				
0.636	0.784	0.765	0.019	2
0.578	0.790	0.770	0.020	2
0.601	0.794	0.776	0.018	
0.606	0.808	0.796	0.012	2
0.6053				
0.650	0.811	0.788	0.023	2
0.563	0.813	0.790	0.023	2
0.6065				
0.595	0.822	0.806	0.016	2
0.595	0.824	0.814	0.010	
0.5950				
0.627	0.831	0.813	0.018	2
0.607	0.832	0.810	0.022	2
0.590	0.833	0.815	0.018	
0.623	0.834	0.815	0.019	2
0.590	0.835	0.820	0.015	2
0.608	0.835	0.820	0.015	
0.6075				
0.645	0.840	0.825	0.015	2
0.610	0.843	0.833	0.010	1
0.612	0.845	0.835	0.010	2
0.6223				
0.610	0.857	0.845	0.012	2
0.630	0.858	0.847	0.011	2
0.620	0.865	0.848	0.017	
0.6200				
0.630	0.873	0.860	0.013	
0.620	0.875	0.866	0.009	
0.616	0.857	0.846	0.011	2
0.614	0.875	0.867	0.008	2
0.6200				
0.640	0.887	0.877	0.010	2
0.641	0.895	0.888	0.007	
0.637	0.897	0.887	0.010	
0.6393				
0.6010	0.906	0.897	0.009	

Using the raw data in **Table 1** it is possible to arrange the drums by lower diameter from smallest to largest. By ordering the drums by diameter, sets or groupings, can be established based on possible position. These

groupings would represent probable ranges for each drum in position from bottom to top. If these groupings are made based on 1-2 cm. increments, there are a total of ten groups. These ten groups then would represent the ten drum positions from bottom to top in a column. It is interesting that we should be provided with representative drums for all positions in a column given the percentage of extant drums.¹²⁸ Within each group there is a limited range of diameters. Some diameter fluctuation for each range might be due to normal expected fluctuation of the original diameters and from the fact that the drums are not exactly of a consistent height for each position, so the joints did not occur at exactly the same level in the columns. Some of the fluctuation might also be due to weathering or could also be due to variability in measurements taken on the drums.

Once the groups are established it is possible to average the heights for each drum position in the series (**Table 2**).¹²⁹ The average heights within each group might fluctuate perhaps by as much as a few centimeters or as much as the range represented, but this method would still provide more accurate results than averaging the entire series together. The major drawback to this method is that the drum diameters fluctuate within their positions by as much as a few millimeters, so that one drum might fit in one position by its lower diameter, but another based on the upper diameter. Therefore, this method can only provide a rough estimation of column height. The ten averaged drums have a total height of 6.082 m. plus a capital of

¹²⁸ Perhaps this reflects the way in which the columns were pillaged for use elsewhere. It seems probable that some of the columns remained with all of their drums nearby after the destruction of the building.

¹²⁹ Here the probability factor of having a representative sample of heights for each drum position would be a problem given the limited number of drums and the fluctuation present.

0.395 m. makes the total height 6.477 m., with a height to diameter ratio of 6.747 times the lower diameter.¹³⁰ **Fig. 34**

¹³⁰ The columns of the Temple of Zeus at Nemea (ca. 320 B.C.) are 6.3421 times the lower diameter (Hill and Williams 1966, 9). The Doric columns of the Stoa of Attalos (mid 2nd century B.C.) as restored are 7.0566 times the lower diameter (Travlos, 1971, 513, Fig. 645). In addition, the Stoa of Attalos columns are spaced every third triglyph, whereas in the South Stoa the columns are spaced every other triglyph, so they could be even more slender than they are.

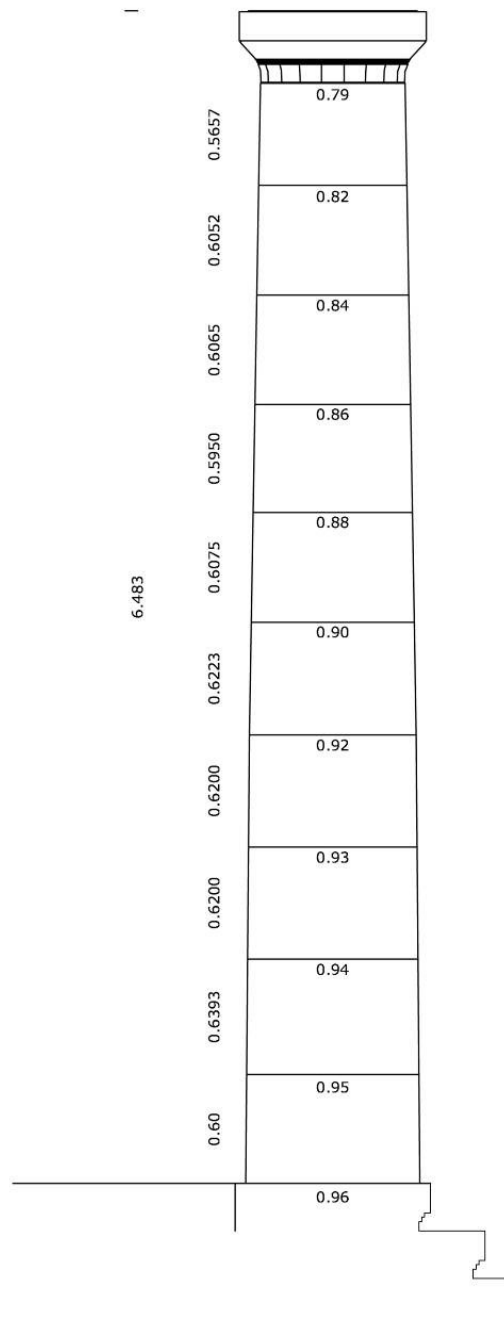

Fig. 34. Column height based on averaging column drum positions.

Another method that might be considered in an attempt to find the height of the columns involves undertaking a Classical statistical analysis of the data; however this requires a random sample from an original population with a normal distribution and a known population size, none of which is present for the drums of the South Stoa.¹³¹ Therefore, the next recourse would be to find a statistical model which allows for all of the above failings. One that has been used with some success is the bootstrap-t method.¹³² In bootstrapping, the existing sample can be used as a guide to population distribution since there is essentially no other option. By running a relatively high number of random re-samples based on the original sample it is possible to derive a more accurate range for the height of the columns than would be possible using a Classical statistical model, however, in cases where this method has been applied the estimate and the ranges produced have so far been a wider spread than can be achieved by other means, such as those employed here.¹³³ Using a bootstrap the average drum height is 0.614., so the column height would be 5.921 m. with nine drums and 6.539 m. with ten drums.

Another way to check the height of the exterior colonnade involves calculating the height of the columns based on the slope from the ridge of the roof. With the height of the center wall and the slope of the roof it should be possible to determine the necessary height of the Doric colonnade. The height

¹³¹ A random sample from an original population is impossible since the population in this case was depleted in a non-random manner.

¹³² See Pakkanen 1998.

¹³³ See for instance, Pfaff 2003, 84. Pfaff's own calculations for the height of the columns of the Temple of Hera at the Argive Heraion, without using the more sophisticated statistical method used by Pakkanen, provide a tighter range than Pakkanen's calculations.

of the wall and its coursing, however, cannot be determined independently with certainty because not all of the wall blocks are present to make up the full height and those that are extant have varying heights. The wall height has been determined for the first floor based on the reconstructed height of the doorways into the backrooms, plus evidence for the run of the staircase in the colonnade, which reaches to the second storey. The height of the second storey, however, is still left to determine.

One other piece of evidence exists from the Roman period remodeling of the stoa that potentially helps to provide a check against other means of determining the full height of the front wall of the backrooms. A monumental entranceway for the South Basilica was built over rooms X and XI, which utilized the line of the front wall of the rooms.¹³⁴ The entrance comprises two Corinthian columns in antis plus an entablature, the top of which would have been no higher than the top of the front wall of the backrooms. This would mean that in the Roman period, the height of the wall had to at least reach to the top of the entablature. Of the two columns, only one full drum, plus fragments of the capitals and the entablature survive. Since there exists only one drum whose height is known, the exact height cannot be determined, but an approximate height for the entrance can be achieved. The total height of the order to the top of the entablature has been posited to be 10.165 m, although this height was arrived at based on the assumption that the missing column drums were the same height as the one preserved.¹³⁵

¹³⁴ See below for a fuller discussion of the Roman entrance to the Basilica.

¹³⁵ See Weinberg 1960, 71.

The slope of the roof has been determined as approximately 1:5 based on evidence from the geison blocks and sloping taenia on two other blocks.¹³⁶ If the wall height is between 10-10.17 m. and the slope of the roof is 1:5, then the exterior colonnade would have to be approximately between 6.30-6.50 m. in height for the supporting structure of the roof to rest against the geison and on top of the frieze. **Fig. 35** If wall blocks of 0.53 m. are used the total height of the column would be somewhere close to 6.35 m. **Fig. 36**

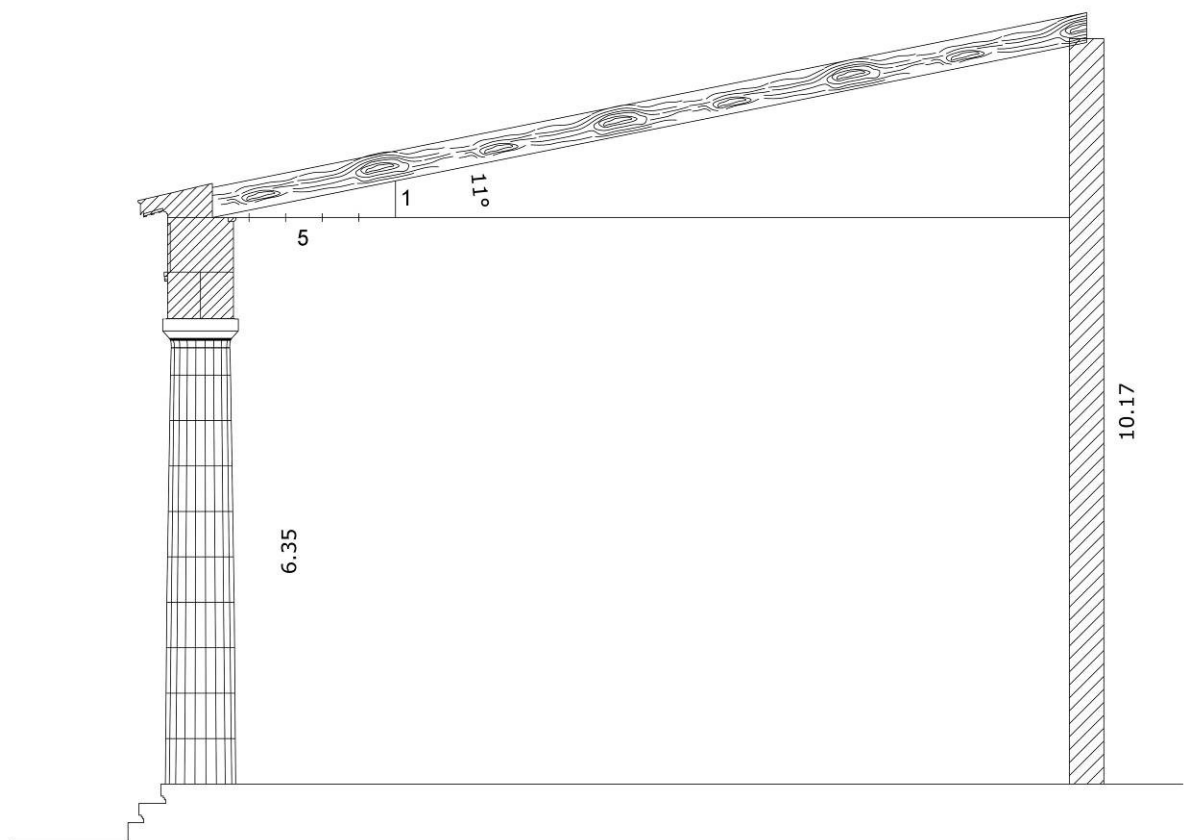

Fig. 35. Column height based on wall height of room front wall and slope of roof as known factors.

This determination of column height based on the slope of the roof and the height of the ridge can in no way be used as absolute, since the Roman entrance cannot be determined with accuracy and if the slope of the roof

¹³⁶ See Broneer 1954, 37, Fig. 13 and 14.

changed even slightly, it would alter the height of the exterior Doric column dramatically, but in all of these methods combined there is agreement that the exterior Doric column is not lower than ca. 6 m. and maybe as high as ca. 6.50 m.¹³⁷

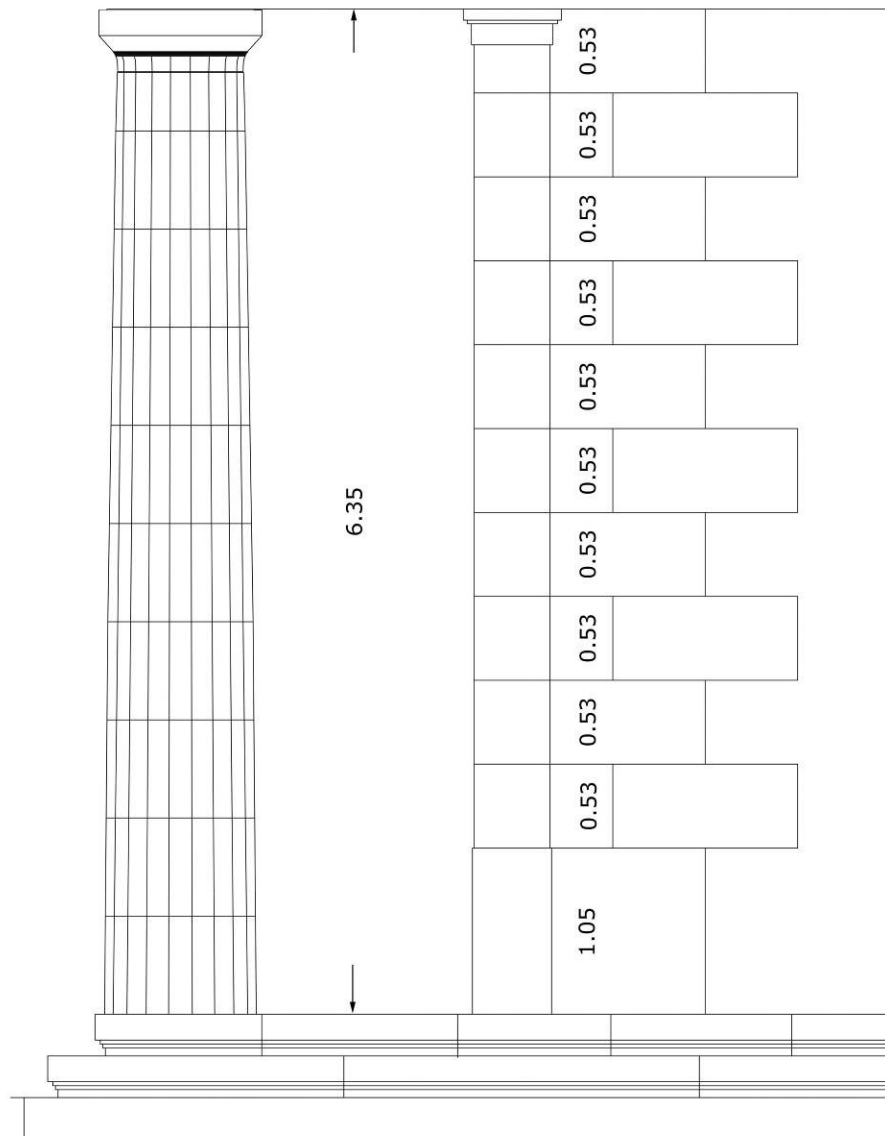

Fig. 36. Hypothetical reconstruction of column height based solely on height of wall blocks being 0.53 m.

¹³⁷ This is at least 30 cm. higher than Broneer's calculations of 5.70 m. (1954, 32).

The proportion of column height to interaxial spacing, if a column height of ca. 6.38-6.39 m. is used, is close to that of the contemporary Temple of Zeus at Nemea and, when compared with other contemporary buildings employing the Doric order, both have slightly greater ratios. For the temple at Nemea, this correlation may point to a connection in design implementation.

Table X. Comparison of Doric Column Proportions

<i>Building</i>	<i>A. Intercolumnnar ratio</i>	<i>B Bay ratio</i>	<i>C Slenderness</i>
Tegea, Temple of Athena Alea	ca. 2.311	ca. 2.669	ca. 6.169
Delphi, Temple of Apollo			
Façade	ca. 2.274	ca. 2.565	ca. 5.835
Flank	ca. 2.250	ca. 2.594	ca. 5.835
Nemea, Temple of Zeus	2.300	2.757	6.342
Stratos, Temple of Zeus	2.435	2.513	6.117
Corinth, South Stoa	2.4375	ca. 2.726	6.645

A=Ratio of interaxial spacing to lower diameter of column
 B=Ratio of height of column to interaxial spacing
 C=Ratio of height of column to lower diameter of column

Column Fluting

The columns have the normal twenty flutes. Previously it was thought that the curve of the fluting was made by joining three arc segments and generally this is the way that the design of Greek fluting has been understood.¹³⁸ **Fig. 37** The sweep of the curve, however, fits an ellipse closely

¹³⁸ Earlier study of the flutes had concluded that the curve was created by connecting three arcs (see Broneer 1954, 31, Fig. 8). Vitruvius posited that flutes could be represented by an arc of a circle. First Stuart and Revett, for the Thesion, and later, Penrose, for the Parthenon, suggested that the cross-section of flutes was created by connecting the arcs of three circles, with two smaller arcs flanking a larger middle arc, creating a tri-centric curve also known as a false ellipse. This tri-centric arc has since become the standard theoretical model for how Greek columns were fluted.

and it has been shown that as early as the 5th century B.C. architects could have worked out the curve using an ellipse.¹³⁹ The method is shown below.

Fig. 38 It can be seen that the preserved profiles of the flutes follow almost exactly the curve of an ellipse, only deviating where the edges of the arrises are broken at the outer edges, which could be accounted for by degradation due to weathering. Given the weathering of the flutes and the roughness of the profiles it is impossible to say for certain that the curve is an ellipse rather than an oval, but the former seems more likely in theory as it could be easily accomplished and the results are more subtle. **Fig. 39** **Fig. 40** Once the curve was achieved, graduated templates could then be made to use for the carving of the flute. Therefore, it is possible that the artisans who carved the fluting used a template based on a true ellipse. While the three segment arc system cannot be ruled out, in the case of the South Stoa it is entirely possible that the curve could have been created with an ellipse.

¹³⁹ It has recently been shown that the flutes of the Parthenon's Doric columns, as well as those of the Pre-Parthenon, were perhaps created by fashioning a template based on a true ellipse (Zambas 2002, 230-232 [English summary]). In practice a true ellipse would achieve a smoother curve and Zambas has shown that its effect on light and shadow would be greater than that produced by an arc of a circle (ibid. 232). See, however, Pfaff (2003, 85-86) who states that the flutes of the Temple of Hera at the Argive Heraion have an apparent circular profile for most of the shaft. Bouras (1967, 39) postulated that the lower flutes of the Stoa at Brauron were arcs of circles, while the upper flutes were false-ellipses.

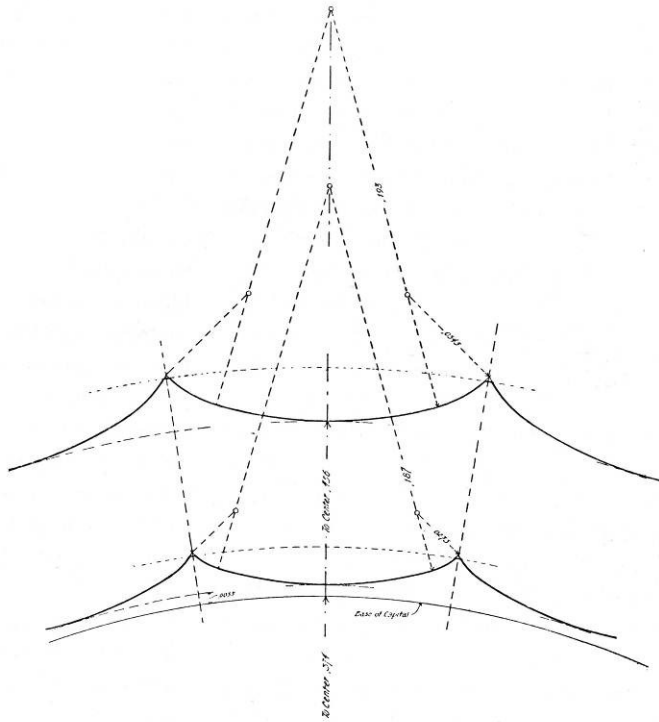

Fig. 37. Construction of flutes according to Broneer, using the tri-centric arc method (Broneer 1954, 31, Fig. 8).

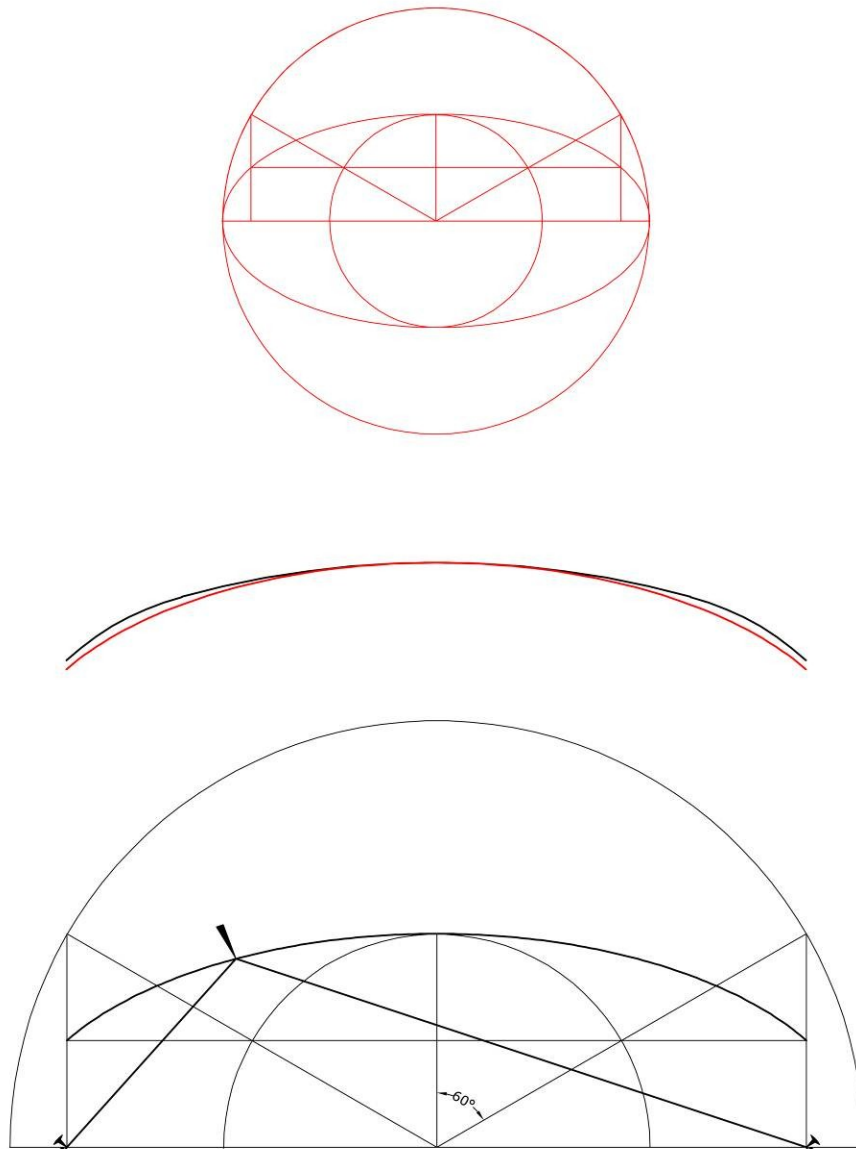

Fig. 38. Theoretical reconstruction of flute profile as intended with the construction of an ellipse. In the middle, the black line is the profile as reconstructed previously using three arcs. The red line is the ellipse. The ellipse would be created using a cord equal in length to the two long sides of triangles with sides $1 : \sqrt{3} : 2$. Following method as outlined by Zambas (2002, 230-232).

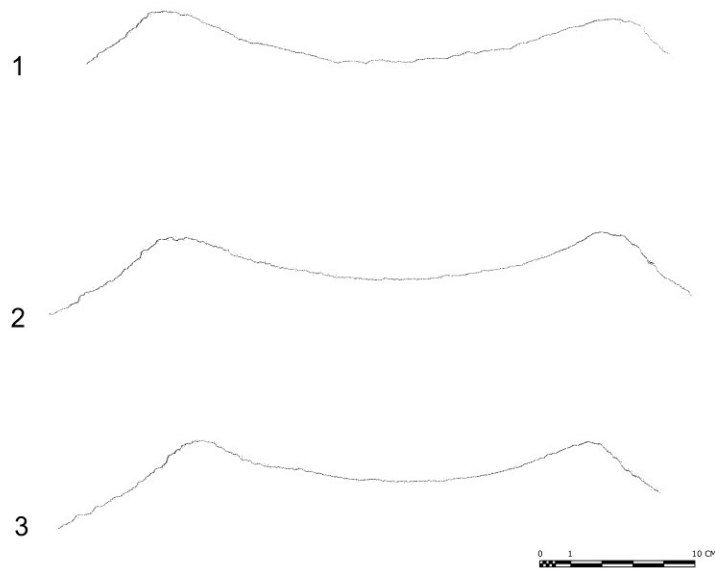

Fig. 39. Sections of flute profiles from 1) Toward top of bottom drum. 2) Middle of second drum at west end. 3) Middle of top drum.

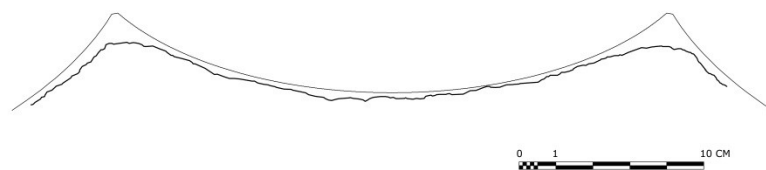

Fig. 40. Bottom drum flute section restored with ellipse profile.

In the South Stoa at Corinth, the column shaft tapers from bottom to top and, based on the preserved drums, the rate of diminution appears to

increase somewhere about the middle of the shaft.¹⁴⁰ If the taper of the shafts increases somewhere at or above the middle of the shaft, it proves that the columns have entasis.¹⁴¹

The nature of the entasis cannot be established with complete accuracy owing to the lack of data. Maximum deflection occurs just below the middle of the column shaft, according to the preserved diameters at the top of the fourth drum, and amounts to 0.0138 m. **Fig. 41**

¹⁴⁰ Broneer (1954, 30) noted that the shaft increased in taper above the middle drum. The measured taper can only be an estimate due to the weathering of the drums.

¹⁴¹ At Didyma the inscribed drawing on the cella wall shows that a single arc was used to create a shallow curve corresponding to an ellipse when elongated, so that each drum taper can be extrapolated correctly (Haselberger and Seybold 1991, 165-188). By tapering the drums in this way, it is possible to create entasis without recourse to extrapolating elaborate curves. In the Roman period there are column shafts that rise vertically to a certain height before tapering. This creates what has been called a "cranked profile". See Wilson Jones (2000, 127-130) on this phenomenon. It is attested for the Temple of Hadrian in Rome, ca. 140 A.D.

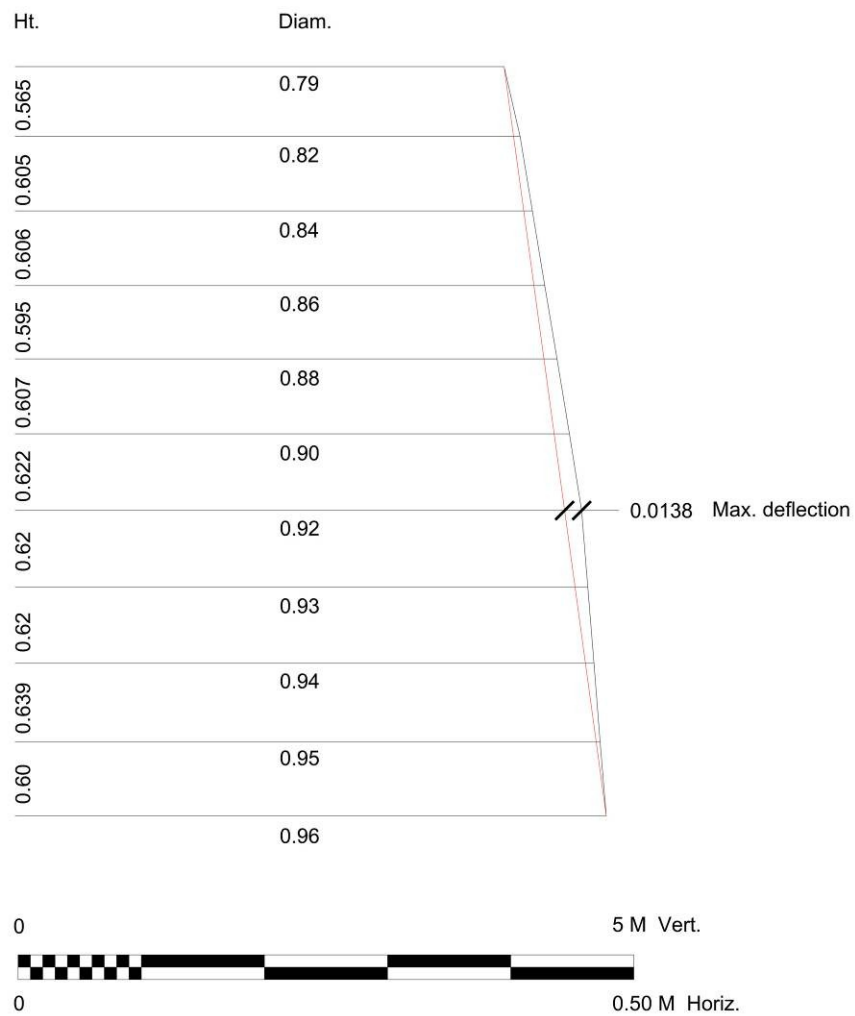

Fig. 41. Column entasis magnified by reduction of the vertical scale 1:10. Showing maximum deflection of column taper. Column heights based on averages.

After determining the taper of each drum, the shaft would only require finishing or smoothing out the transitions at the joints between each drum, if necessary, once all the drums were set in place and the flutes were carved. In practice, however, the junctions between drums would be so slight as not to require smoothing out. That the process of establishing diminution is not just a simple mathematical formula involving the difference of overall taper by the number of drums is proven by the fact that all the drums are not of equal

height, nor are the differences of taper simple fractions. A template such as that made for the Didyma columns could be used to check the diameter for each drum at the top and bottom, relative to its position in the shaft, no matter what the height of the drum.

Due to the tilt of the curvature attested for the front foundations, the lowest column drums should exhibit a slight correction in the top surface angles. **Fig. 42** The amount of tilt on the east and west end columns would be a maximum of 0.0035 m., which should be reflected in a difference in heights on the sides of the lowest column drums, so that the upper surface of the drum is horizontal. **Fig. 43**

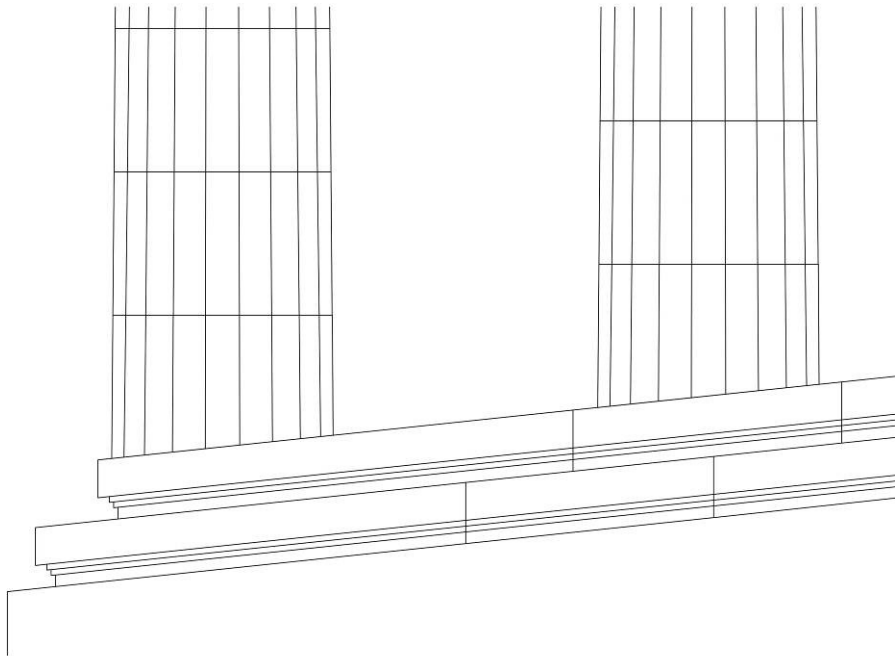

Fig. 42. Hypothetical drawing showing the tilt problem incurred by the columns on a stylobate with curvature (curvature exaggerated).

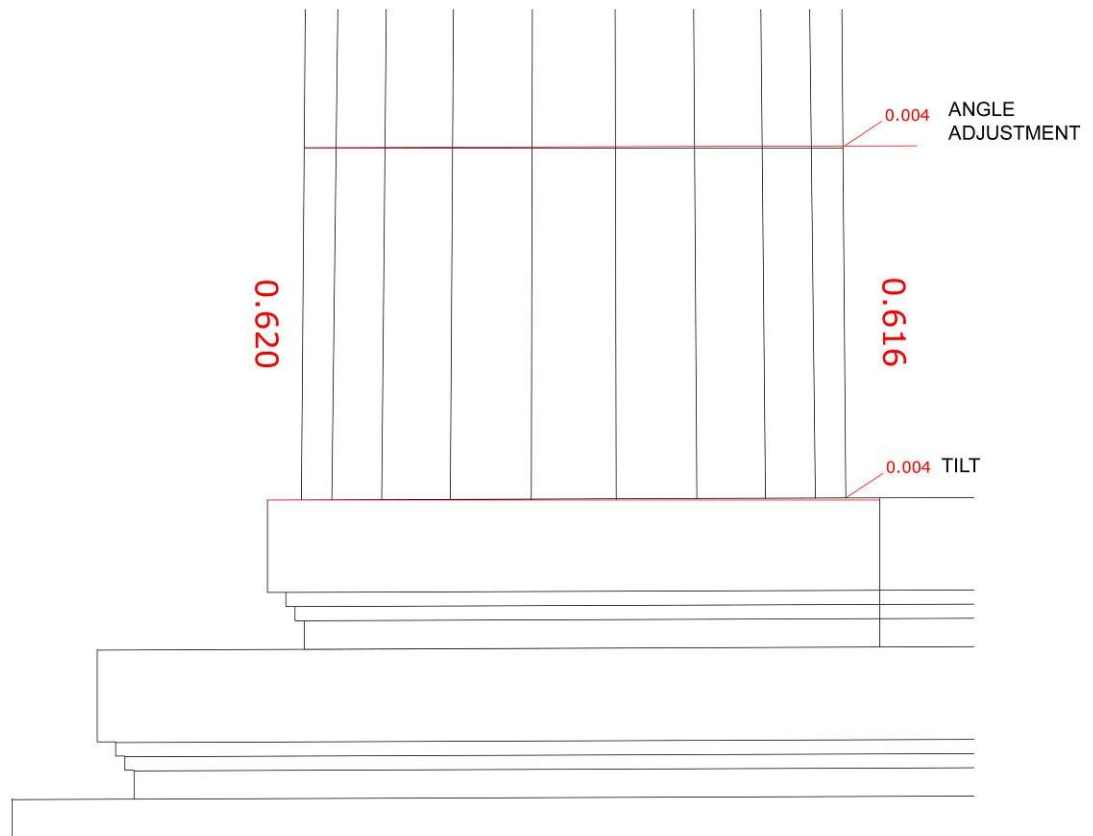

Fig. 43. Theoretical adjustment in lowest drum to correct tilt effect of horizontal stylobate curvature on column.

If horizontal curvature is steady along the stylobate, the tilt correction should be different for each position of a column and less toward the center. It is also possible that the curve rises steadily and then flattens out toward the middle, in which case the tilt correction would not be needed along the middle section. The only drum in situ happens to be the lower corner drum at the west end, but even here the difference is not apparent. Based on the preservation of the drums, it is not possible to measure the correction or its direction along the axis of the building.

Based on direct evidence from the drums, it appears that the columns were not inclined, but inclination cannot be ruled out owing to the poor state of surface preservation on the drums. Again, it should be expected that the

lowest column drum would exhibit angle correction, which, if there was inclination, should be more appreciable than tilt correction. The best evidence that inclination of the columns at the corners does not exist comes from the alignment of the frieze and the stylobate at the west corner, where the rhythm of the stylobate blocks indicate the frieze's position could not be moved inward toward the east to accommodate column inclination or the rhythm of the frieze and stylobate would be thrown off, if the present calculations set out above are correct.

Doric Capitals

There are three exterior Doric capitals partially preserved. **Fig. 44** The abacus measures ca. 1.028 m. on the sides and ca. 0.162-0.17 m. in height.¹⁴² The echinus to the annulets measures 0.10 m. in height. **Fig. 46** The echinus terminates in four annulets. The annulets are 0.286 m. in height. The necking is 0.098 m. high. At the base is a relieving surface 0.005 m. high, set back 0.02 m. and there is a relieving surface on top of the abacus ca. 0.93 m. in width, set back 0.05 m. from the edge, of similar height with chamfered edges. The diameter at the base of the fluted neck measures 0.748 m. inside the flutes and 0.794 m. on the arrises. The profile of the echinus is nearly straight, terminating at the top with a small curve running to meet the abacus. **Fig. 47** The top of the abacus of the capitals has a hole ca. 0.05 m. on its sides and approximately 0.05 m. deep, set in the middle. Based on the fact that the preserved architrave block does not have a dowel cutting in a position for doweling into the abacus, the cutting on the abacus must be for something

¹⁴² For the Doric capitals of the exterior façade see also Broneer 1954, 30, 32 and Fig. 8, reproduced here as **Fig. 45**.

else and it has been suggested that a cutting in this position on the abacus may be for securing the capitals to a lathe-type of device to aid in carving the circular forms of the capital.¹⁴³ The bottom surface of the capitals has an empolion cutting.¹⁴⁴ **Fig. 45** and **Fig. 46**.



Fig. 44. Doric capital from north façade.

The preserved capital illustrated in Fig. 45 has a dowel cutting on the upper surface of the abacus, which, if original, may mean that this capital belongs on the corner, where the architrave could be doweled at this point.¹⁴⁵

¹⁴³ See Pfaff 2003, 96 and n. 41 for a full discussion of this idea, first proposed by L. von Klenze; Hill and Williams 1966, 39; Orlandos 1955-1958, 2, 139-140. Also Pliny (*NH* 36.90) for the use of the lathe for carving stone.

¹⁴⁴ As Broneer noted, the smaller cutting is not centered inside the bigger cutting. The drums of the Temple of Hera at the Argive Heraion have empolion cuttings in which the larger cuttings themselves are not centered, although they do not have counter sunk holes inside Pfaff (2003, 91). Un-centered empolia are also found in the Temple of Apollo Bassitas (Cooper 1996, 231). This would seem to be an argument against the notion that empolia serve for grinding the drums into place. See Dinsmoor 1950, 390, on the definition of the terms *dowel* and *empolion*. In general an empolion is a wooden block between two column drums, inside of which there is usually, but not always, a center pin also of wood.

¹⁴⁵ I thank Chris Pfaff for pointing this out to me.

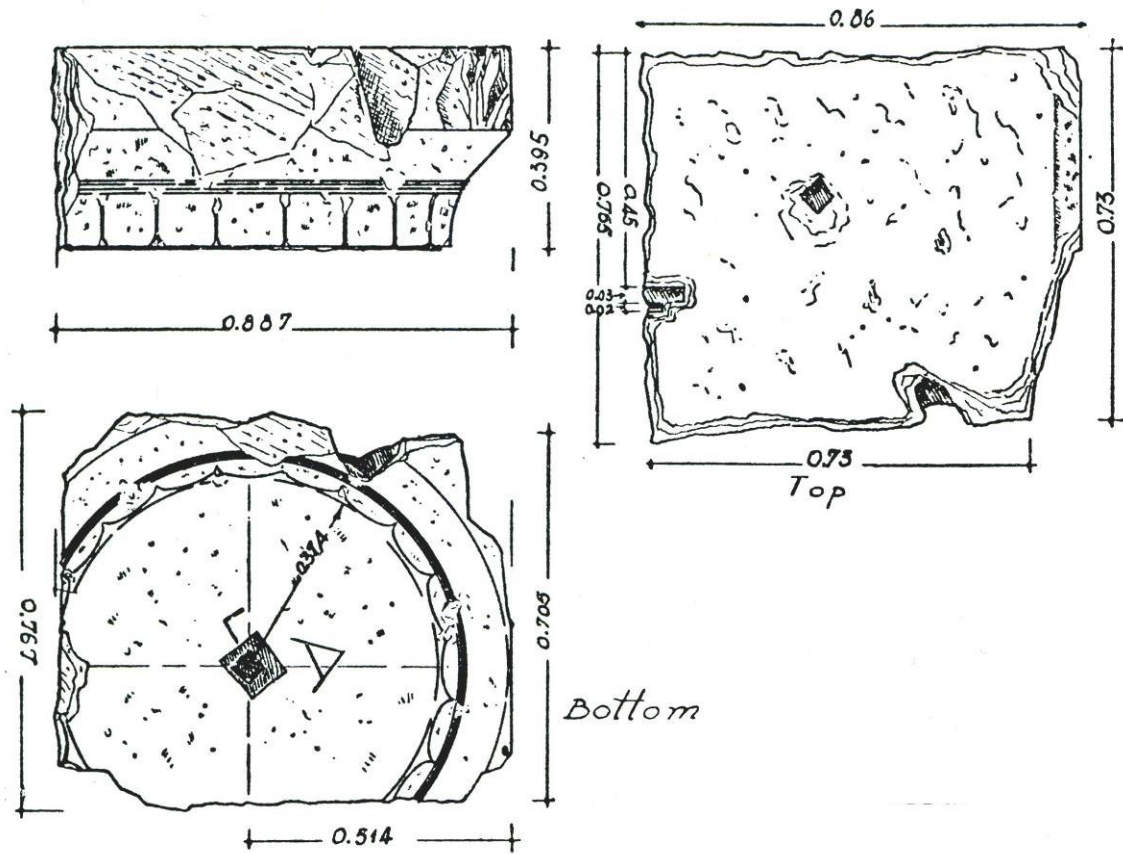

Fig. 45. A preserved Doric capital illustrated in Broneer's publication (1954, Fig. 8).

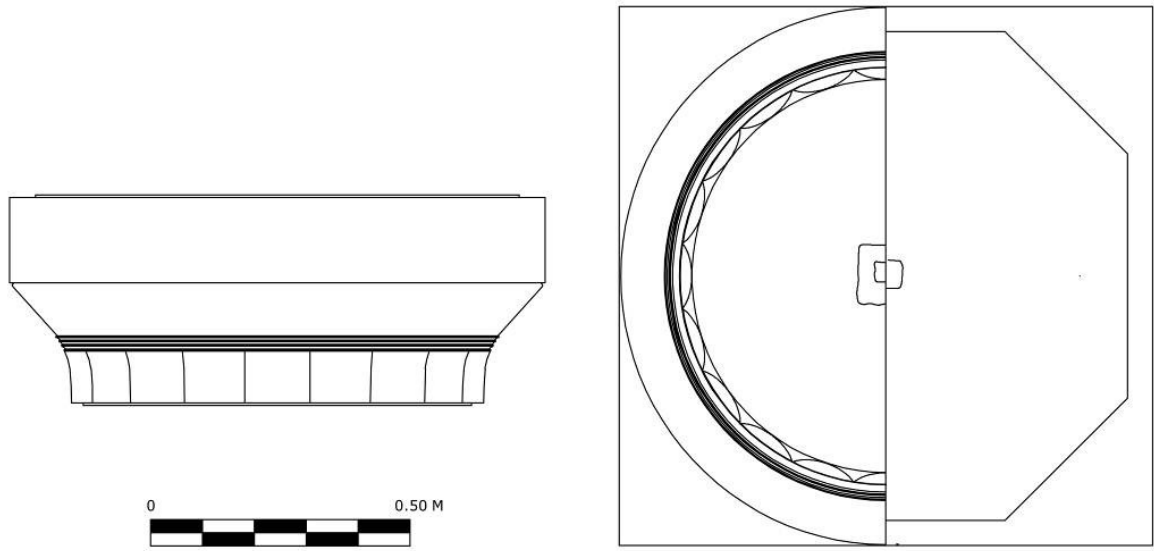

Fig. 46. Doric capital elevation. Bottom and top views.

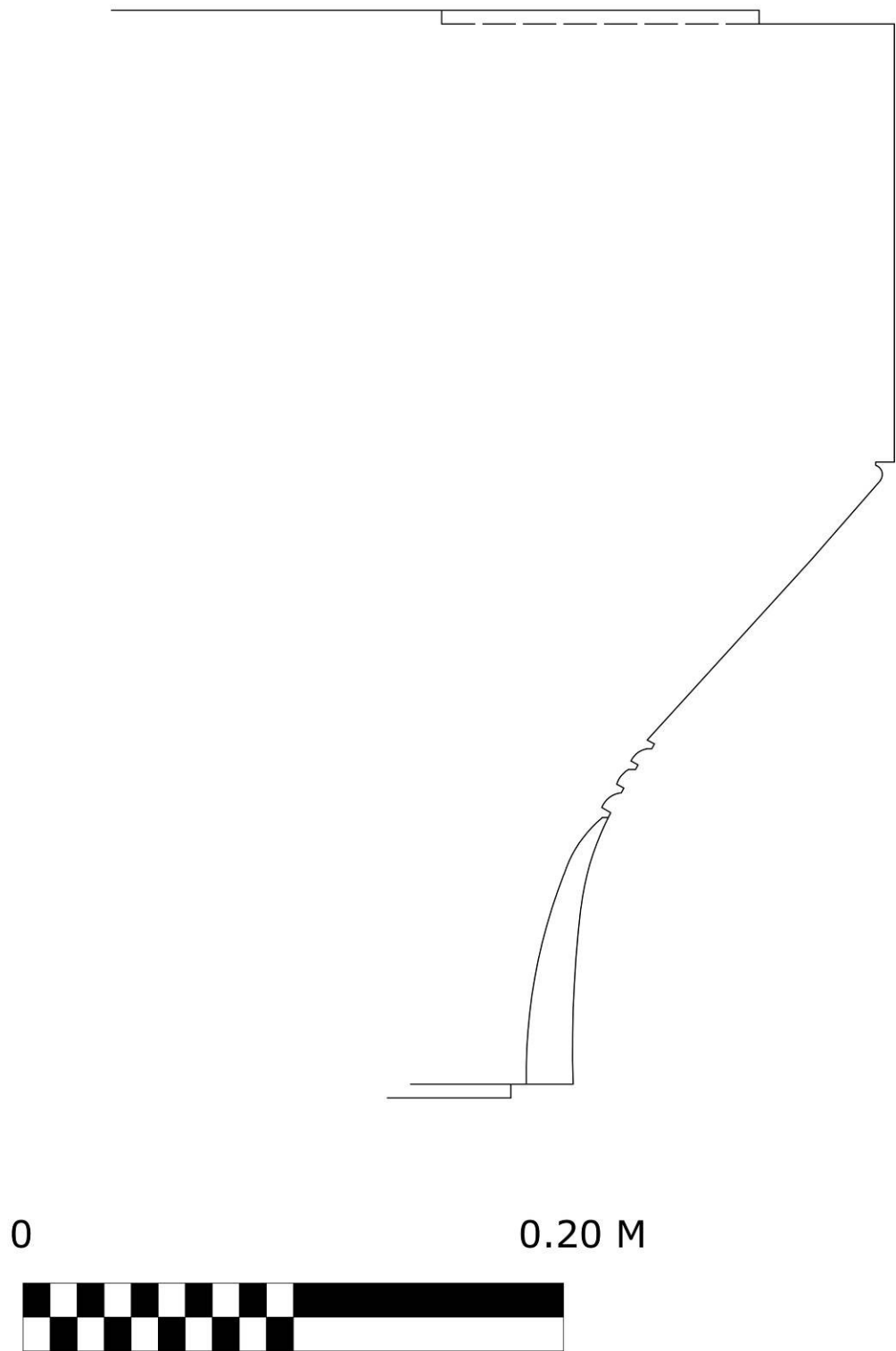

Fig. 47. Restored profile of the Doric capitals from the north colonnade.

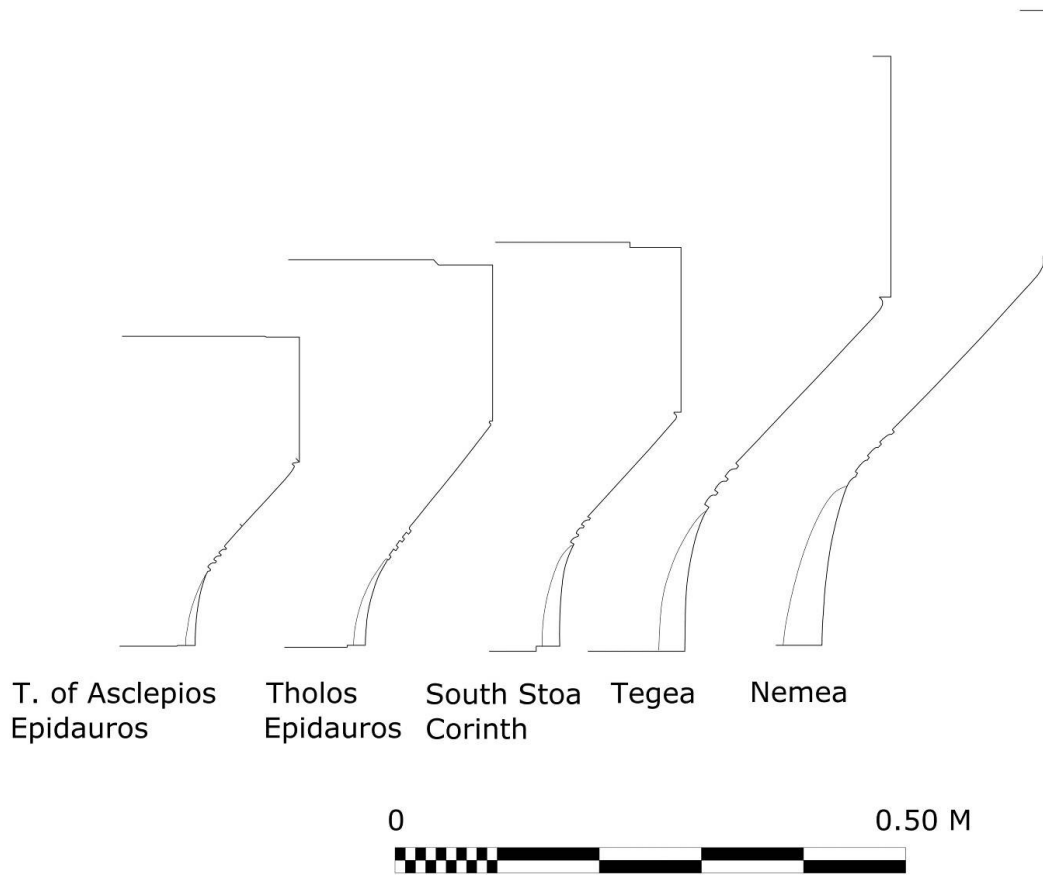

Fig. 48. A selection of 4th century BC Doric capital profiles in the Peloponnese.

The straightening of the echinus, so that it is essentially a truncated cone shape rather than a subtle curve, occurs in the second half of the 4th century B.C.¹⁴⁶ **Fig. 48** The carving of a small curve at the transition from the echinus into the abacus is typical before the 3rd century B.C. after which typically there is a vertical rise to the abacus.¹⁴⁷ That the South Stoa capitals have retained the earlier feature may be taken as conservative, or it may be

¹⁴⁶ See Roux, 92, Fig. 16 for the profile of the capitals of the Tholos at Epidauros dated to the mid-4th century. Compare the echinus of the capitals of the stoa at the Amphiareion in Oropos, which is slightly curved. (Coulton 1968, Fig. 8A). This stoa dates to the mid-4th century B.C. (ibid. 180-183).

¹⁴⁷ Compare this to the Doric capitals at Nemea and the Temple of Artemis at Epidauros, which terminate in a vertical line into the abacus, a feature that is common after the end of the 4th century B.C. Hill and Williams (1966, 11 and Fig. 10) regard the capitals of the Temple of Zeus at Nemea as transitional, since the date of the temple is thought to be in the 320s B.C. The date of the South Stoa is discussed in detail below.

that both types continue into the beginning of the 3rd century before the incurving lip disappears. In any case it is clear that both types exist in the Argolid and Corinthia from the late 4th to early 3rd centuries B.C.

The annulets of the capital are separated by a sharp groove, which is typical of annulets of the 5th and 4th centuries.¹⁴⁸ In the regional sphere of the Argolid and Corinthia this type is most comparable to the Temple of Asklepios at Epidauros.¹⁴⁹ The flutes of the capital fade into the annulets, following the normal practice of the 5th and 4th centuries.¹⁵⁰

In terms of proportional analysis of capitals, the traditional model has been to assign changes to stylistic development over time.¹⁵¹ As Coulton points out, however, the developments witnessed cannot be simply ascribed to smooth or gradual evolutionary changes, but advanced in relatively abrupt shifts alternating with static periods in what could be termed a steeped progression. In fact, it is the consistency of design during given periods and geographical areas which is more striking and allows for proportional rules to

¹⁴⁸ Contrast this with the capitals of the stoa at Oropos, which have annulets separated by semicircular grooves, paralleled apparently only at Thorikos. According to Coulton (1968, 170). Also, as Coulton points out (*ibid.*), later annulets become broader and the groove simpler. Compare for example the Stoa at Samothrace (Saviat 1962, 297, Fig. 25); the Stoa of Cotys at Epidauros (Roux 293, Fig. 89).

¹⁴⁹ For the capitals of the temples at Tegea and Nemea the curve of the annulets appears to be less smooth, but this could be due to how they were drawn in the restoration. Possible variations might also be due to the difference in limestone used and the degree to which stucco was applied to the capitals as well as variation of carving in limestone versus marble. The Tholos at Epidauros has a very distinct rectangular groove, which is paralleled in the Portico of Philo at Eleusis and, according to Coulton, possibly in the Palace at Vergina (1968, 171). For Eleusis see Noack, 126, Fig. 56.

¹⁵⁰ In the Argolid and Corinthia, this can be seen in the Temple of Asklepios and Tholos at Epidauros, the Temple at Tegea. After the 4th century B.C. flutes are sliced by the echinus well below the annulets (on this point see Coulton 1968, 171); however, in the Temple at Nemea (ca. 320 B.C.), the cone of the echinus extends below the last annulet.

¹⁵¹ Coulton 1979, 82.

be tested.¹⁵² The proportional rules established by Coulton for Doric capitals of the 4th century B.C. are based on results from comparison of a set of thirty-two capitals, and the rules that he established are as follows:¹⁵³

Coulton's Theoretical Proportional Rules for 4th Century Capitals

A. Abacus width =	$1 \frac{1}{16}$ x lower diameter of column
B. Diameter of necking =	$\frac{4}{5}$ x lower diameter of column
C. Capital height =	$\frac{3}{8}$ x abacus width
D. Abacus height =	$\frac{2}{5}$ x capital height
E. Echinus height =	$\frac{15}{32}$ x (capital height – abacus height)

South Stoa Doric Capital: Proportional Analysis

	Actual	Theoretical value based on Coulton's Scheme
A. Abacus width	1.028	1.02
B. Diameter of necking	0.794	0.768
C. Capital height	0.395	0.3825
D. Abacus height	0.162	0.153
E. Echinus height	0.129	0.107

As the above table shows, the South Stoa capitals differ slightly from the proportional values that would result if the theoretical values set out by Coulton for his group 8 (4th century) capitals were followed. The major differences are the actual abacus height, which is almost 0.01 m. taller than

¹⁵² Coulton *ibid.* 82. Coulton examined a total of 214 capitals ranging from Archaic to Hellenistic date.

¹⁵³ Coulton *ibid.* especially 99-103. The data displayed in histograms is examined for the highest coefficients of correlation between pre-defined relationships (eg. diameter/height). Coulton points out that discrepancies greater than 0.01-0.02 m. (ca. 1 dactyl) which do exist, are a problem, but may be due to any number of reasons from error to rounding, to modification of conventional rules by the designer.

the theoretical value, the slightly broader neck diameter and taller echinus height, while the total height is in fact less than expected. The broader neck reflects a stouter column that tapers less than expected. The taller echinus height, over 0.02 m. higher than Coulton's theoretical value for this group, might reflect a conservative proportion from earlier 5th century practice. It seems possible that these discrepancies might be explained by classifying the capitals as transitional, however, Coulton cautions against making assertions of this kind regarding development.¹⁵⁴ Alternative values might be imposed to achieve better results. For instance, the capital height is almost exactly half the upper diameter ($0.794/2 = 0.397$), which seems like a logical proportional rule.

A question still exists with respect to the derivation of the module used for the capital. What was the starting point on which the capital's proportions were based and its design executed? Vitruvius' rules for designing Doric capitals would divide the height of the capital into three equal parts and the full height would be equal to one module.¹⁵⁵ As Coulton points out, considering Vitruvius' sources, this may have only applied to capitals after the beginning of the Hellenistic period and indeed he shows one capital from the heroon at Assos which does seem to follow these rules with very slight discrepancies. The South Stoa capital does not follow Vitruvius' prescriptions.¹⁵⁶ **Fig. 49**

¹⁵⁴ Coulton *ibid.* 102. "Capitals with transitional proportions may well not be transitional in date, while changes from one proportional rule to another may well be abrupt."

¹⁵⁵ *Vitr.* iv. 3.4.

¹⁵⁶ Coulton 1979, 81; also *ibid.* note 5 for Hellenistic capitals from Delos that closely follow Vitruvius' rules.

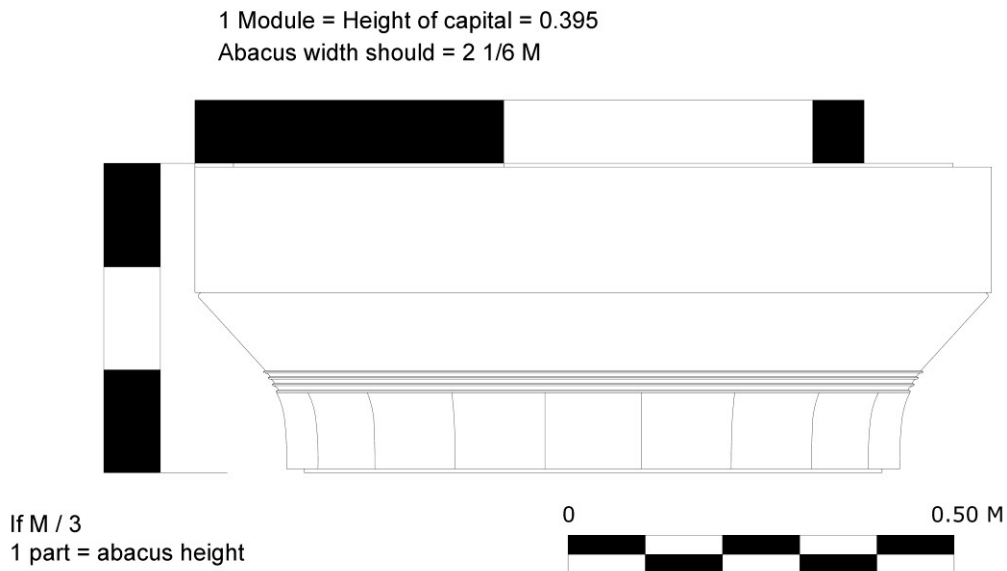

Vitruvian rules compared to actual design of South Stoa capital

Fig. 49. South Stoa capital compared with Vitruvius' rules for design.

Vitruvius gives precedence to the abacus, so that the division in height is based on one part being the height of the abacus.¹⁵⁷ Clearly in the case of the South Stoa capital, the height is not divided into three parts based on the height of the abacus, nor is the width of the abacus based on this height as a module. In addition, Vitruvius does not provide any clues as to an external measurement that could be used as a module for the capital's proportions.

Coulton gives precedence to the lower column diameter as an external measurement from which the module could have been derived. Not only can the upper column diameter be derived from this, but also the abacus width and in turn all the other parts.

¹⁵⁷ Vitr. iv. 3.4.

Chapter 5

Interior Ionic Columns

Shafts and Bases

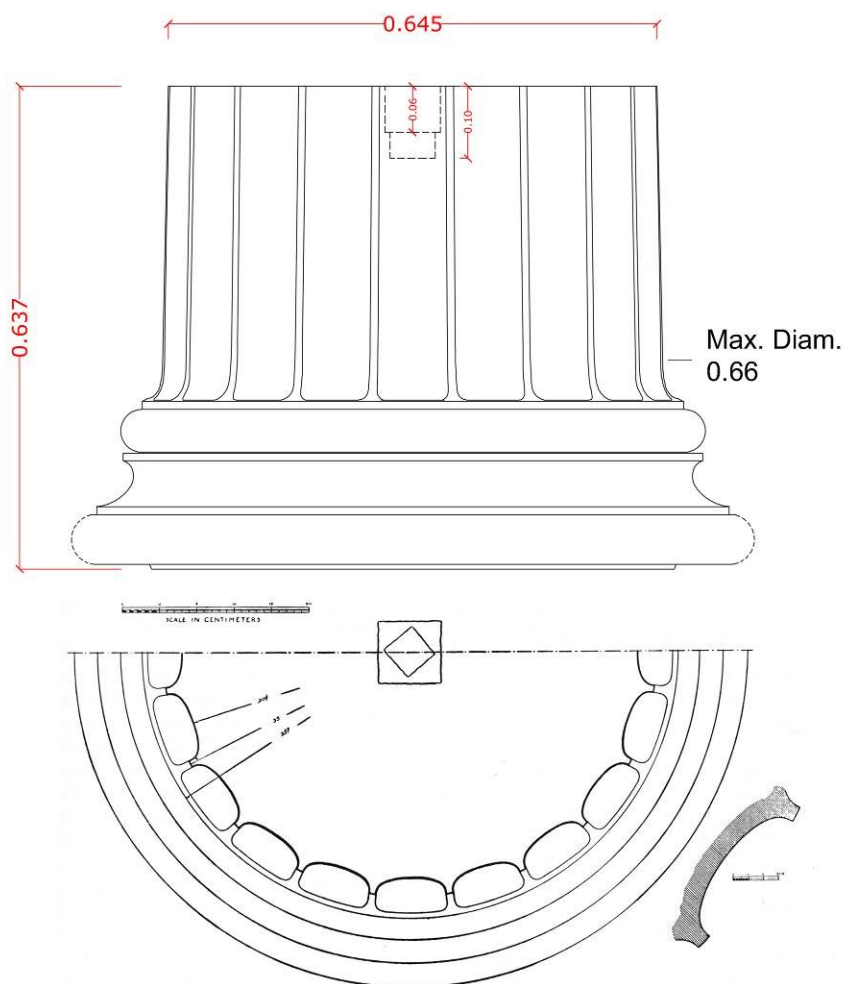

Fig. 50. Reconstruction of Greek Ionic column base of interior colonnade. After Broneer (1954, 47, Fig. 25).



Fig. 51. Ionic column base from the Greek period of the stoa.

There is one lower section of a shaft with a base preserved from the interior Ionic columns of the Greek period.¹⁵⁸ **Fig. 50** and **Fig. 51** Together, the shaft and base measure ca. 0.64 m. in height. The base measures 0.22 m. in height and has two toruses with a scotia between and a relieving surface on the bottom with a height of 0.005 m. There is an empolion cutting (0.084 m. square and 0.06 m. deep) in the top of the drum with another smaller cutting (0.044 m. square and 0.034 m. deep) inside set diagonally to the larger cutting. The shaft has twenty flutes 0.096 m. in width at the base with fillets 0.01 m. in width. This type of Ionic base, in which the top torus is slightly receded from the line of the bottom torus, is typical of the Classical and

¹⁵⁸ The base, along with the capitals, were originally assigned to the lower interior order by Broneer (1954, 45-48, and Figs. 23, 25). The size of the columns, with a lower diameter of 0.66 m. on the fillets, seems too small to work with the outer Doric colonnade if reconstructed to the height of the ceiling. The Roman Ionic columns (see below) with lower diameter of ca. 0.90 m. on the fillets, added as replacements in at least part of the building, are closer to what the normal proportions for the Greek period should be. See discussion below.

Hellenistic periods. It is an Attic type developed in the 5th century and it is the type most often used in the Peloponnesos in the 4th and 3rd centuries. The curve of the flutes is flatter than later Hellenistic and Roman fluting, when it tends to be nearly half a circle. Broneer noted the deep cavity of the fluting where it joins the base.¹⁵⁹ **Fig. 52** Comparable bases from the Peloponnesos tend to have a shallower interior flute cavity at the base, for example in the Portico of Cotys at Epidauros. **Fig. 53**

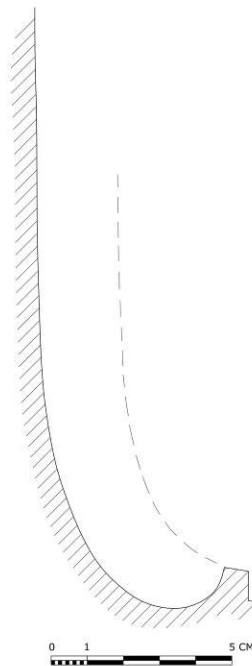

Fig. 52. Interior flute profile bottom of Ionic column (after Broneer 1954, Fig. 25).

¹⁵⁹ Broneer 1954, 46.

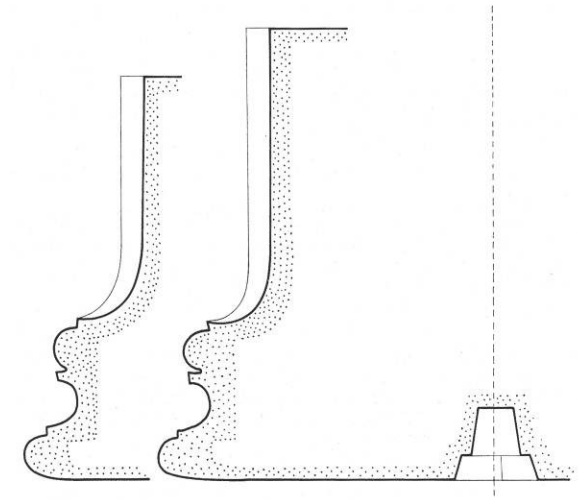

Fig. 53. Portico of Cotys at Epidauros. Ionic base profiles.

This technical detail is not usually dealt with in published descriptions of Ionic bases and it is only when the profile happens to be given that one can make a comparison. A close parallel for the deep scoop of the fluting at the base exists at Nemea for the Corinthian columns of the Temple of Zeus, but there it is on a torus-cavetto base. It is possible that the deep cavity was introduced to provide more shadow for columns that were in the interior of the building, where they would not be subjected to rain and collection of dirt in the hollows.

The choice of twenty flutes rather than the more common number of twenty-four flutes seems to be a Peloponnesian feature. What became later normal practice was already established in the Archaic period with Polykrates' temple at Samos which called for Ionic columns to have twenty-four flutes, while twenty is the normal number by the Classical period for Doric. Dinsmoor states that for Ionic columns the number was reduced to twenty-four (earlier Ionic capitals could have as many as fifty flutes) because of the deeper curve

of the flutes combined with the addition of wider fillets.¹⁶⁰ In the Peloponnesos, however, twenty flutes became the canonical number for Ionic columns. Roux states that the reasons for this are three-fold.¹⁶¹ First is the technical factor that most Ionic columns of the Peloponnesos are of local, friable limestone. Lessening the number of flutes adds to the resistance of the edges and the overall strength of the columns. The second reason is aesthetic. The first use of twenty flutes occurs with the Corinthian and Ionic columns inside the Temple of Apollo at Bassai and the Tholos at Delphi. In both buildings it was necessary to have slender column proportions in the interior, so reducing the number of flutes increased the appearance of solidity. The third reason is that in the Peloponnesos, where the Doric tradition was already so strong, the adoption of twenty flutes for Ionic columns should not be surprising.

Roux's first reason seems valid in one respect regarding Peloponnesian limestone being friable, but the idea that the fewer the flutes that are cut into the columns the greater the stability is debatable. There may be less flutes to break, but the column's stability will not be increased by lessening the number of flutes. The second reason is more problematic. It is true that the early use of such slender columns might engender a feeling of weakness and perhaps the architect felt that fewer flutes would give the impression of strength, however, twenty-four flutes were no problem for the columns of the Erechtheion which are at the extreme end of slenderness (over 1:10), especially for the 5th century. In the Nike Temple the columns are stout by comparison with a diameter to height ratio of just over 1:7.

¹⁶⁰ Dinsmoor 1950, 135.

¹⁶¹ Roux 1961, 334-336.

Aesthetically, reduction of flutes is not a simple formula of slenderness equals less flutes. In fact, Vitruvius instructs that, particularly for interiors, adding more flutes to a slender column will make it seem stouter (the opposite argument to Roux).¹⁶² The converse, of subtracting flutes, might then be applied for columns with stout proportions. It may be that Vitruvius is speaking only about very tall columns, like those in Asia Minor with which he would have been familiar, rather than the relatively small scale columns of the Peloponnesos. If this is true, it means that the proportional rules would vary depending on the magnitude of the scale. Whatever the case, beginning with the engaged columns of the Temple of Apollo at Bassai, twenty flutes had become the norm for Ionic by the end of the 4th century in the Peloponnesos when the South Stoa was constructed.¹⁶³ There is no reason to think that it was anything more than a convention for Corinthian architects working on the South Stoa.¹⁶⁴

¹⁶² Vitruvius (4.4.2-3) states that “If they (the columns) seem a little too slim, then, if the exterior columns have twenty or twenty-four flutes, give these twenty-eight or thirty-two. Whatever has been subtracted in reality from the body of the column shaft is apparently increased by the additional number of flutes...”. Perhaps this aesthetic reason should be given some credit for some interior columns which are left entirely unfluted, although the practical reason, that it made sense to leave the columns with a protective collar because of pedestrian traffic, would still probably have been a strong concern.

¹⁶³ Cooper (1996, 286 n. 13) refers to Roux on the use of twenty flutes for the Temple of Apollo at Bassai, but is otherwise silent as to this innovation for Ionic in the Peloponnesos.

¹⁶⁴ It is interesting that the Corinthian columns of the Tholos at Delphi also have twenty flutes, further supporting a Peloponnesian and/or Corinthian connection there. The use of twenty flutes for Ionic is also found in Macedonian architecture of the early Hellenistic period. See the column base from the House of Dionysos at Pella (Makaronas-Giougri 1989, 57, Fig. 58).

Capitals

Several fragments of the Greek Ionic capitals from the South Stoa are preserved. All are small fragments, most of which were found in well deposits.

Fig. 54 and **Fig. 55** The good state of preservation on many fragments indicates they were probably deposited shortly after their destruction.

Because of their preservation, it was possible to form a complete reconstruction of the capitals as they would have appeared. **Fig. 56**, **Fig. 57** and **Fig. 58**



Fig. 54. Ionic capital fragment. Two views showing abacus and volute.



Fig. 55. Ionic capital fragment. Bolster and neck from below.

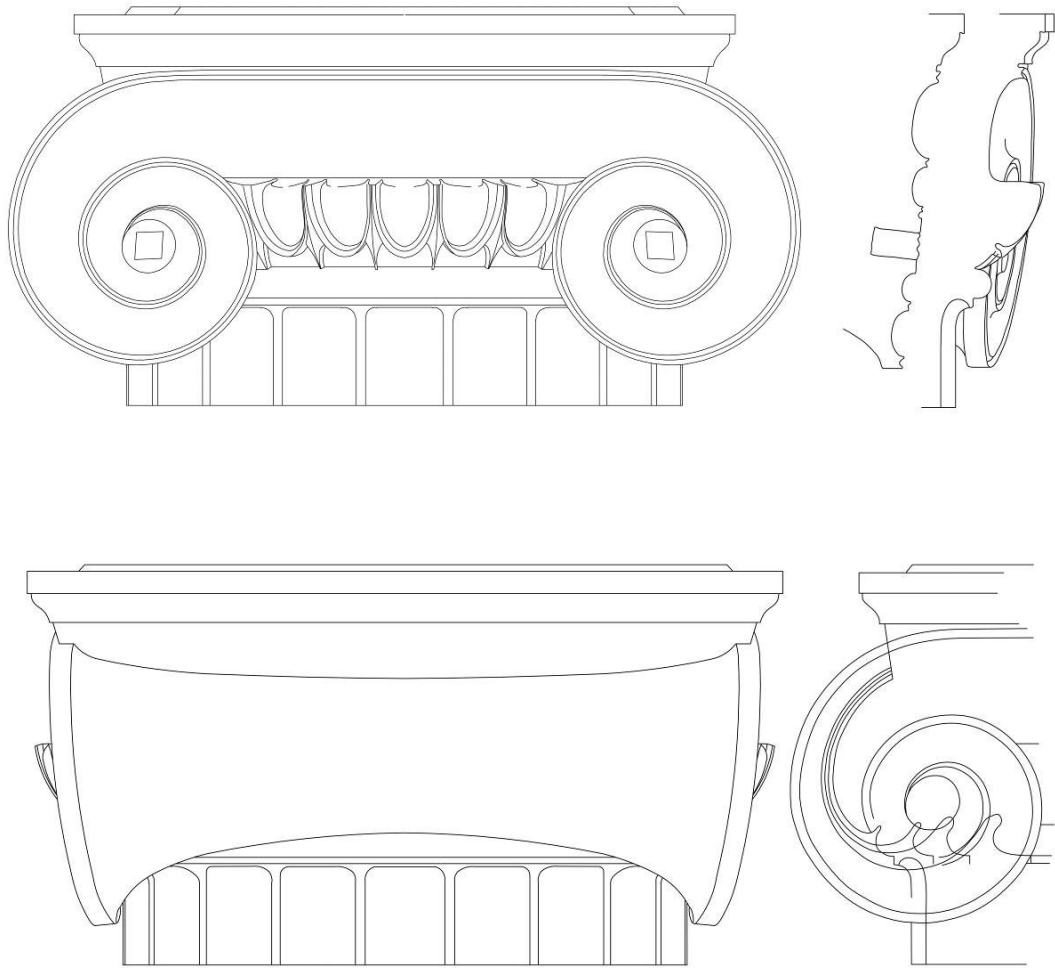

Fig. 56. Interior Ionic capital (after Broneer 1954, Figs. 22 and 23).

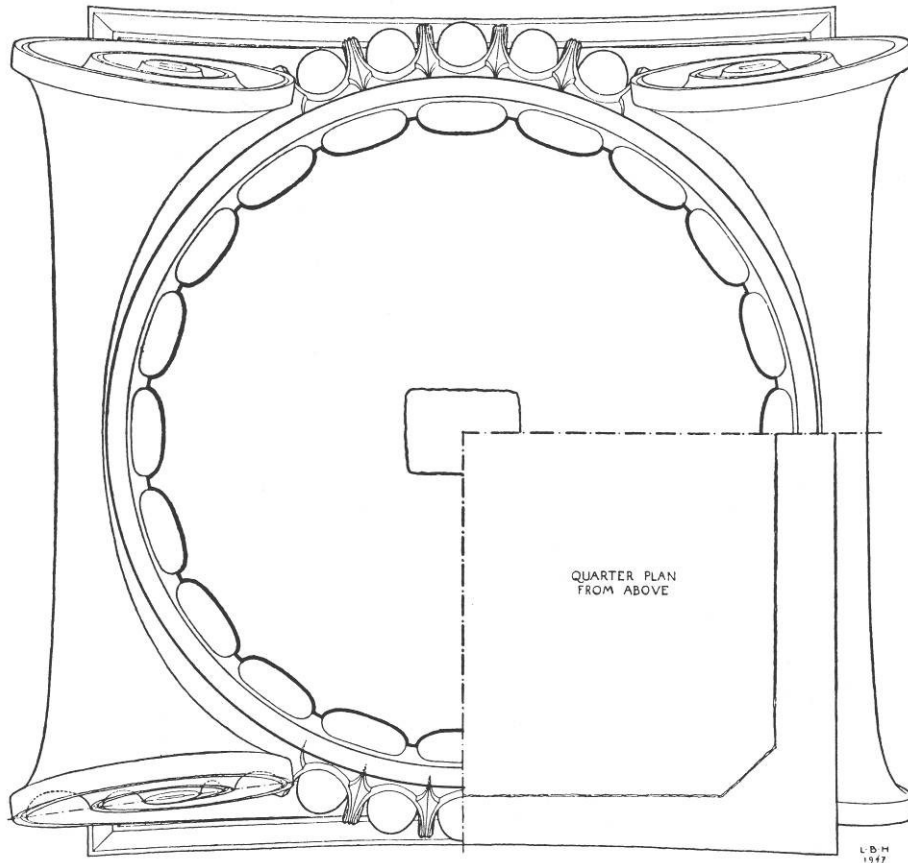

Fig. 57. Restored plan view of Ionic capital (Broneer 1954, Fig. 24).

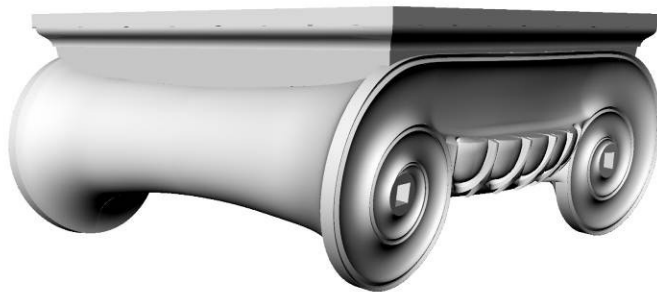

Fig. 58. Perspective model of a Greek Ionic capital from the interior of the South Stoa (Rhino model by G. Herdt).

Roux categorizes Ionic capitals in the Peloponnesos into two types. Type I with a two part echinus and Type II with a “normal” echinus. The interior Ionic capitals of the South Stoa belong to his second type with normal echinus, while this version of the type has no palmettes.¹⁶⁵ The South Stoa and the Leonidaion at Olympia both fall into this category.¹⁶⁶ The volutes are curved, inclined vertically, and the eye of the volute is a flat disk with a square cutting for the insertion of an eye.¹⁶⁷ The centers of the eyes of the volute are level with the lower quarter of the echinus. Palmettes are lacking in the angle of the junction between echinus and volutes.¹⁶⁸ According to Coulton, the omission of palmettes is common for Peloponnesian Ionic capitals with a two-part echinus and occasionally also occurs in the normal type prior to the beginning of the 3rd century, after which palmettes are usually added.¹⁶⁹ The lower line of the canalis of the South Stoa capitals is straightened, a feature that typically occurs after the early 4th century B.C. A good example of this occurs in the Philippeion at Olympia.¹⁷⁰ This feature, of straightening the upper or lower lines of the canalis, is one of the few features that allows for some evidence of dating according to Coulton, as is the lack of palmettes.¹⁷¹ Taken together, the lack of palmettes and the straightening of the lines of the canalis would seem to support a date for the Ionic capitals of the South Stoa

¹⁶⁵ The South Stoa Ionic capitals according to Roux’s classification are of the second variety type in the Peloponnesos, Roux 1961, 394.

¹⁶⁶ Coulton 1968, 176.

¹⁶⁷ See the Type I (Peloponnesian style) capital from Oropos with square holes for inset eyes (Coulton 1968, 162, Fig. 11).

¹⁶⁸ Cf. the capitals in the Leonidaion and Palaistra at Olympia.

¹⁶⁹ Coulton 1968, 176.

¹⁷⁰ Coulton 1968, 177 notes at Perachora, the capitals have a strongly curved canalis, while at Pella there is an Ionic capital with the upper line of the canalis strongly curved, but the lower line is straight (illus. BCH lxxxiii [1959], 704, Fig. 21).

¹⁷¹ Coulton, *ibid.*

anywhere from the middle to the end of the 4th century B.C. The lack of a border for the lower edge of the canalis above the echinus is not uncommon in Peloponnesian Ionic, another feature which should set it apart from Athenian or Attic Ionic, which usually has a lower border carved or painted.¹⁷²

One additional point, which has been overlooked previously, concerns the possibility of a connection between the addition of palmettes or lack thereof and the effect that would have on the lower lines of the canalis. The Ionic capitals from the House of Dionysos at Pella have corner palmettes and the lower line of the canalis is curved, while the upper line is straight. **Fig. 59** If the lower canalis were straight as well, the palmettes would not fit in the corners or they would have to overlap onto the canalis. Therefore, to avoid this problem, the lower line curves up to meet the corner at the point from which the palmette begins. This is essentially what happens in two sets of Ionic capitals from Oropos, although there the palmettes are blocked out on a flat surface and would have been depicted in paint and it is the palmette outline that defines the bottom line of the canalis. **Fig. 60** It is interesting that in both the Oropos capitals, the upper line is straight, while the lower line is curved in the type II form, yet in the type I form it curves to follow the upper curve of the palmettes but straightens out in the center. There are cases where the lower edge of the canalis is curved, but there are no corner palmettes, a good example being the Bassai Ionic capitals. What this evidence may suggest is that the height of canalis in relation to where the volutes sit may have had a bearing on whether or not the canalis is straight or

¹⁷² Compare the capitals for the North Propylon at Epidauros (Roux 1961, Figs. 68 and 69).

curved, but it would also depend on whether or not palmettes were added.¹⁷³

If the lower line of the canalis is brought up to the top of the volutes, then there is no problem adding palmettes if it is straight, which is what is seen in later Hellenistic and Roman capitals.¹⁷⁴

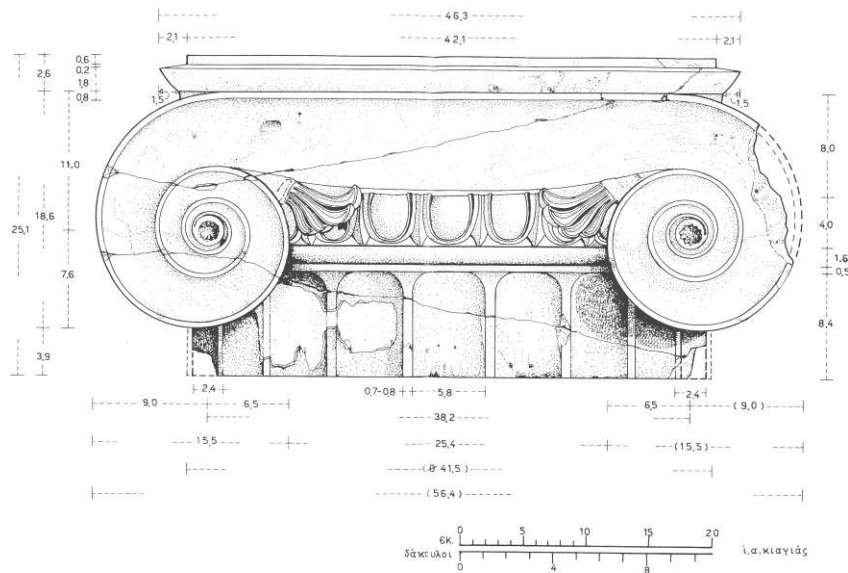

Fig. 59. Ionic capital from the House of Dionysos, Pella (Makaronas 1989, Pl. 11).

¹⁷³ For Ionic pier capitals, such as the capitals in the second level of the Stoa of Attalos, the height of the canalis is reduced so that while the line of the canalis is straight, the corner palmettes are not a problem.

¹⁷⁴ This starts already in the Hellenistic period with pier capitals of the Ionic order, like those in the Stoa of Attalos. For an example of a Roman capital with straight canalis and palmettes we need look no further than the Roman replacement columns for the interior of the South Stoa.

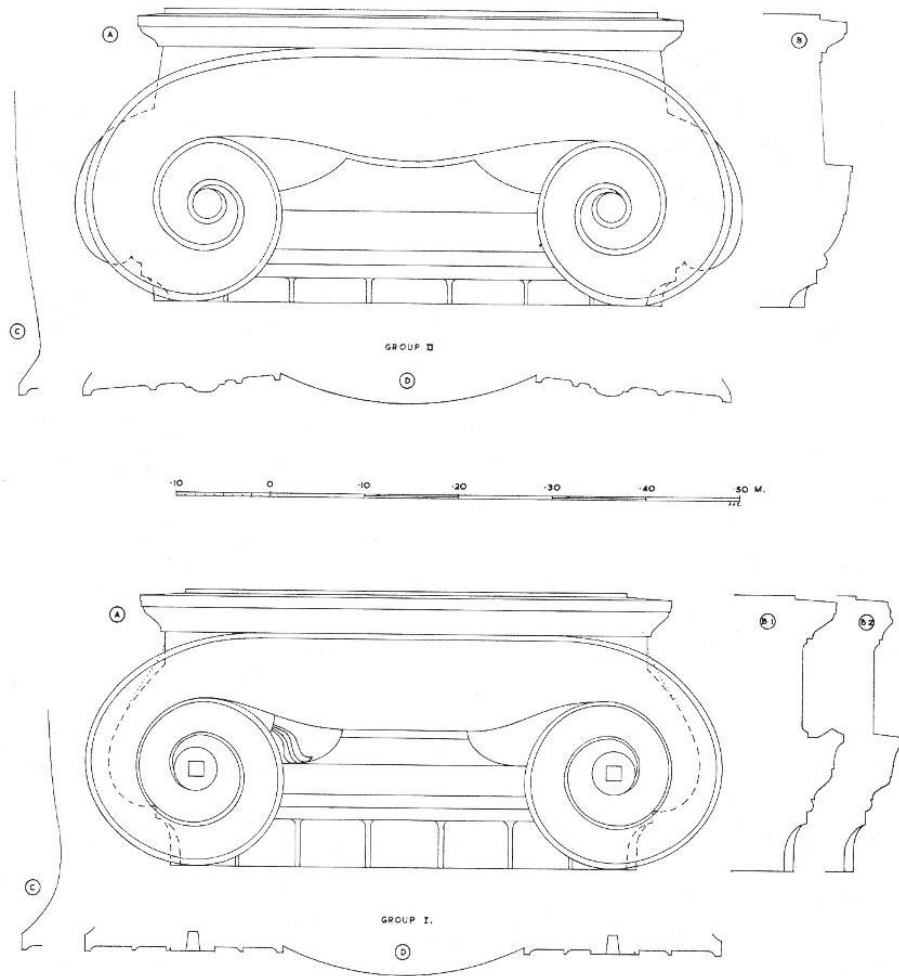

Fig. 60. Type I and II forms of Ionic capitals from Oropos (Coulton 1968, 162, Fig. 11).

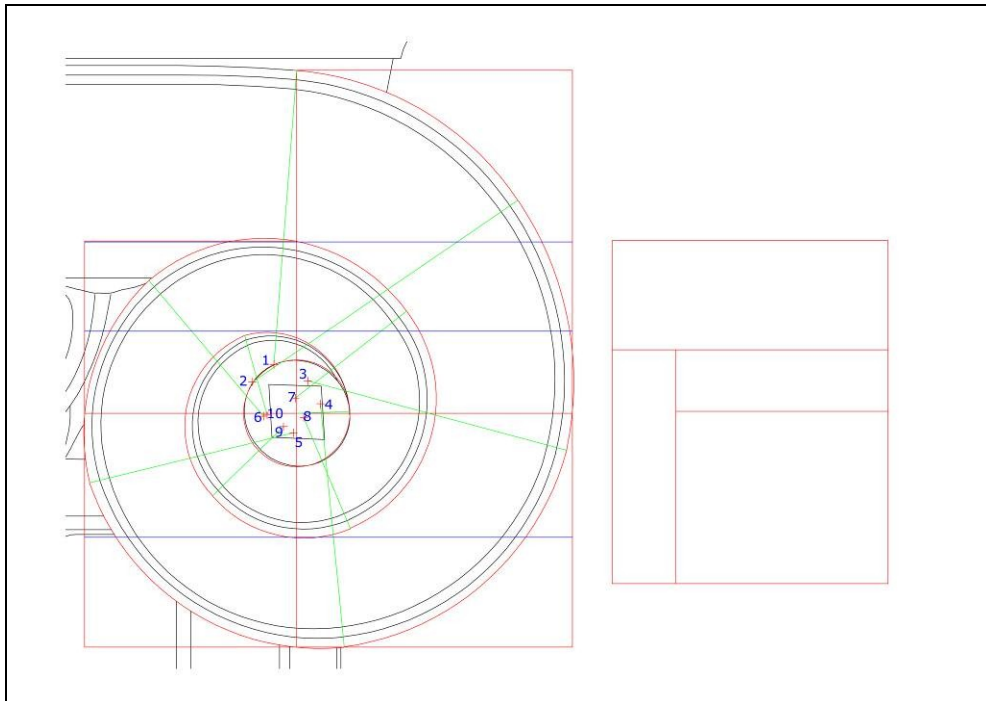
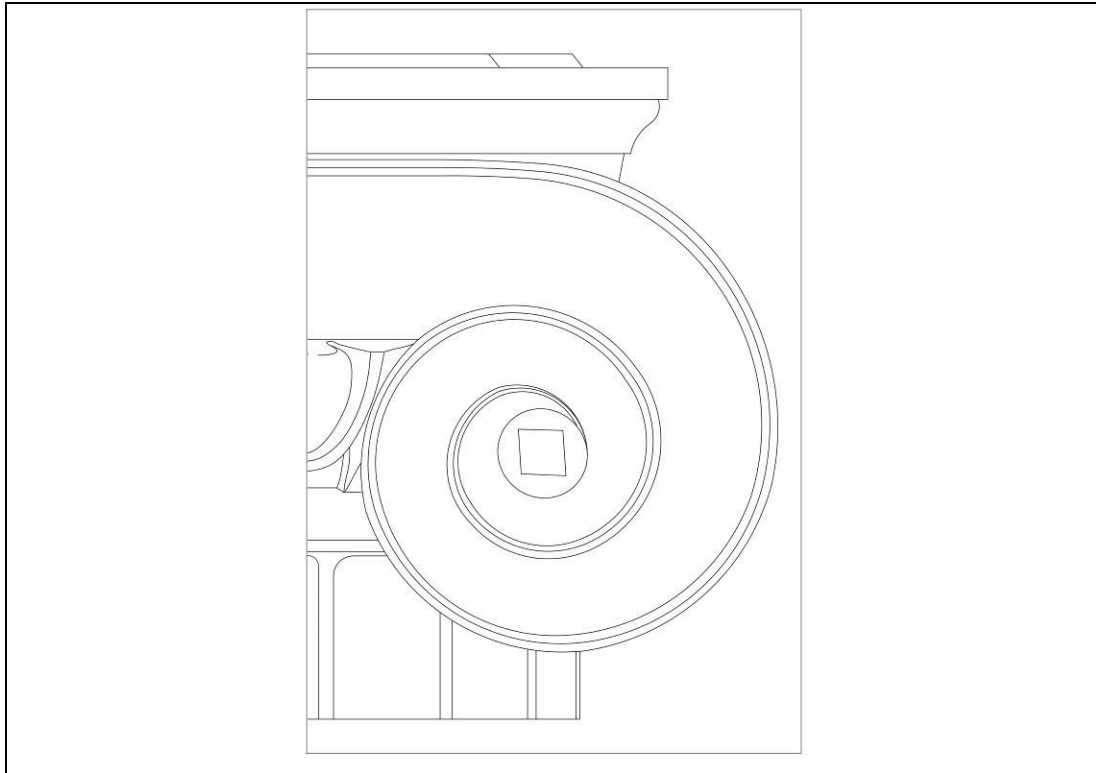

Fig. 61. Analysis of the volutes of the Ionic capitals from the interior. The arcs used to reconstruct the volute and the centers found are derived from ten circles which are not justified by physical evidence, nor do they represent the way the volutes were originally created, but are the way the volute was reconstructed in Autocad.

Previous analyses of volute spirals on Ionic capitals reveal that there was no set system for forming the spiral. What does seem consistent is the use of a compass working from the center oculus to form a series of circles.¹⁷⁵ Analysis of the volutes of the South Stoa capitals reveals that the arcs of ten circles made up the initial turning of the volute. **Fig. 61** This would seem to be an excessive number of arcs relative to the number of turns and could be due to the fact that the volutes are not strictly vertical. Seven of the centers of the arcs fall to the inside of the center eye and three centers fall to the outside of center. The centers do not appear random, but rather, after the first swing of the volute, they turn in a clockwise spiral of their own, but whatever diagram or geometry that might have been used to design the spirals, the final adjustments by the artisans were made by eye and leave little room for discovery of a pattern to the turns. The height of the volute as measured is 0.294 m. and the width is 0.25 m.¹⁷⁶

The interior Ionic colonnade presents one of the more difficult problems for the reconstruction of the South Stoa. The columns have a base diameter of only ca. 0.66 m. measured on the fillets as compared to the exterior Doric columns which have a base diameter of 0.96 m. on the arrises. This

¹⁷⁵ See Cooper 1996, 297-298 and note 4 for bibliography. "There have been enough analyses of curves on finished Ionic capitals and of sketch lines and compass points on unfinished examples to know that not one but a number of geometrical systems for constructing a spiral existed in antiquity" (Ibid., 297). The only full study devoted to the topic of how the spiral was designed in ancient Greece is Penrose (1902). Richard Anderson (pers. comm.), Agora Excavations architect who measured and drew the examples for Shoe's study of Athenian Ionic capitals (Shoe 1996), concluded that of the twenty capitals with preserved volutes, no two capitals used the same arrangement of compass points nor, more importantly, were any compass points arranged in convenient geometrical shapes. See also Stevens 1931, 135-144 on the volute of the capitals from the temple of Athena at Priene. For the Roman period, see Vitruvius 3.5.6, 3.5.8.

¹⁷⁶ The height is close to 0.2925 m. which lends credence to this measurement being the theoretical foot used in the building, as discussed concerning the design of the frieze and the krepidoma.

constitutes a major difference between outer and inner diameters. In Broneer's reconstruction the interior colonnade must reach at least to the level of the top of the exterior Doric architrave course in order to support the roof construction of horizontal beams running from the top of the Doric frieze across to the top of the wooden architrave above the interior Ionic columns.¹⁷⁷ The Doric colonnade has now been determined to be somewhere between ca. 6.30 m. to ca. 6.50 m. in height. This height plus that of the Doric architrave (0.635 m.) means that the total height that the Ionic columns must reach is at least 6.93 m. in order to support the roof. With a lower diameter of 0.66 m., the diameter to height ratio of the Ionic columns would be 1:9.5 (calculating the total column height with the base). Given the double spacing of the interior colonnade, this seems improbable. A diameter to height ratio of 1:9.5 is not out of the question for Ionic columns, but such slender columns would be definitely odd for an interior stoa colonnade in comparison with the ratio of the exterior colonnade (1:6.6), especially considering that the intercolumnar spacing is twice that of the exterior order, and the columns must help support the weight of the roof.¹⁷⁸

The reconstruction of the staircase at the west end of the stoa provides a possible solution to the height problem, however, since it indicates that a balcony should exist in front of the backrooms and that it should extend out to the line of the interior colonnade for support. This would mean that the interior

¹⁷⁷ The height problem for the Ionic columns seems to have been the single overriding reason that Broneer lowered the exterior order to 5.70 m. even though the evidence suggests a taller Doric column. See section above on the Doric columns.

¹⁷⁸ The ratios for the exterior Doric and interior Ionic orders of the Stoa of Attalos, for which the reconstruction is secure, are much closer (1:7.056 and 1:7.768 respectively). That the lower interior columns of the stoa are so stout there in comparison to "normal" Ionic proportions is probably due to the fact that the columns must also support an upper floor and are juxtaposed with the exterior Doric columns.

colonnade rises only to the height of the lower level ceiling and floor level of the upper level. The run, in height, of the staircase coincides with the height of the ceiling and upper floor of the backrooms, which, based on evidence of the doorways and wall height, would mean that the beam support for the balcony and stairs could be set somewhere around 5 m. in height. Therefore, the Ionic columns would need to rise to a height of ca. 4.50 m. to 5 m. to support the balcony, with piers rising above to support the roof and a balustrade for the balcony. With a base diameter of 0.66 m. and a total height of ca. 4.95 m., the diameter to height ratio would be close to 1:7.5 D.¹⁷⁹ **Fig. 62** Having proposed this height for the Ionic columns, it is worth comparing them with the replacement columns of the Roman period, when the balcony they supported was most likely removed. This proportional relationship is best seen against the backdrop of the Doric column. **Fig. 63** It would seem odd if the Greek Ionic capitals were even taller than the Roman replacements.

¹⁷⁹ A proportion between 1:6 and 1:7 for the interior columns of the stoa can be compared to the interior columns of the Gymnasium at Olympia, built slightly later. There, the interior Ionic columns are ca. 1:7-1:8 and they carry a much lighter load as well as being more closely spaced (Mallwitz 1972, 282).

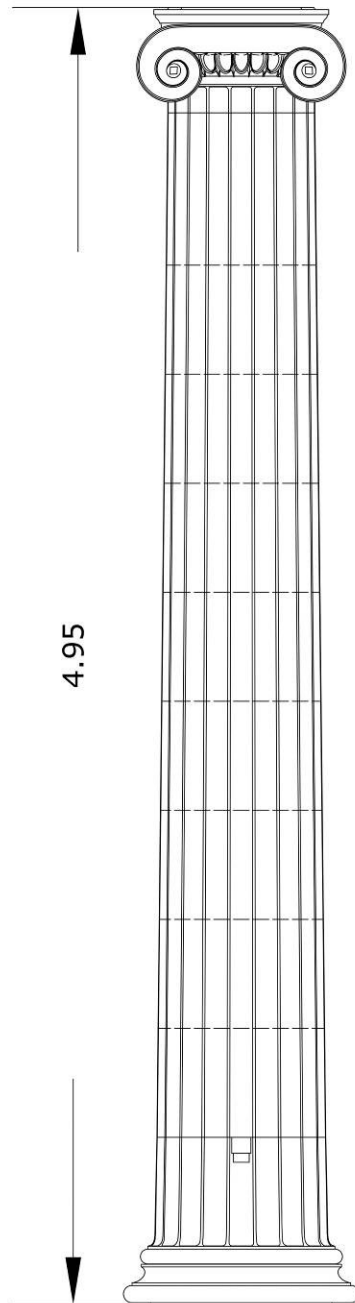

Fig. 62. Hypothetical reconstruction of Ionic column. Column diameter to height ratio of 1:7.5.

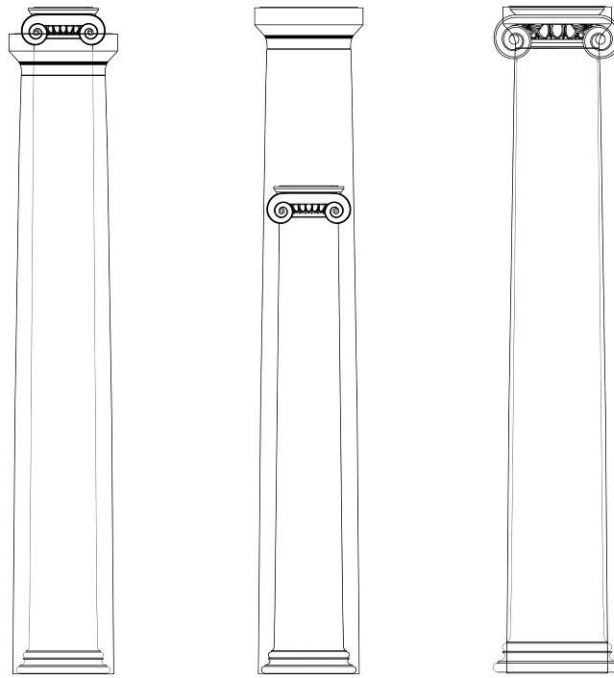

Fig. 63. Proportional analysis of the interior Greek Ionic columns compared with the exterior Doric columns. 1. Greek phase according to Broneer. 2. Greek phase with new column heights 3. Roman phase.

While it is true that Ionic columns in temple design tend toward slender proportions in relation to Doric from the 5th century onwards, Ionic columns in stoas tend to have a lower diameter to height ratio closer to their Doric counterparts.¹⁸⁰ Since the interior colonnade in stoas typically has a double intercolumniation, it follows that the diameter to height ratio might be greater,

¹⁸⁰ According to Coulton, there is a “tendency for Ionic columns to be lower in relation to their lower diameter than in temples generally.” (1976, 120). One exception would be in the stoa at Perachora, where the Ionic pier columns appear to be quite slender when viewed from the front, which is made possible by their being, in fact, pier columns, so the depth more than makes up for their width in terms of strength.

both for strength and for aesthetic desirability.¹⁸¹ The Following table shows a comparison of proportions for Ionic columns in temples and stoas.

Table of Column Proportions¹⁸²

Ionic Proportions in Stoas		Ht./Diam.	Intercol.
Stoa of Naxians, Delos	Mid 6 th c.	8.89	2.315
Stoa of Athenians, Delphi	Early 5 th c.	8.48	3.58
Stoa at Oropos	ca. 360	8.96/8.15	5.66
Abaton, Epidauros	1 st half 4 th c.	8.49	4.70
Stoa of Philip, Megalopolis	ca. 340-330	8.2	6.30
<i>S. Stoa, Corinth</i>	<i>ca. 300 B.C.</i>	<i>ca. 7.5</i>	<i>4.68</i>
Magnesia on the Meander	Early 2 nd c.	8.7	4.50
Stoa of Attalos, Athens	Mid 2 nd c.	7.75 (L)	4.855
North Stoa, Priene	3 rd qtr. 2 nd c.	8.45	4.65
Vitruvian Stoa		9.36	
Temples			
Ilissos Temple, Athens		8.25	
Nike Temple, Athens		7.82	
Erechtheion, Athens (N. Porch)		9.35	
Apollo Temple, Bassai		8.93	
Athena Temple, Priene		8.84	
Artemis Temple, Ephesos		9.60	
Kybele Temple, Sardis		8.95	
Apollo Temple, Didyma		9.74	
Zeus Temple, Magnesia		9.55	

As can be seen in the table for stoas, the height to diameter ratio of the South Stoa Ionic columns falls below the low end. Since, however, the South Stoa columns carry a balcony and the proportions are set in relation to an upper storey, the only stoa with which the proportions can be truly compared in the above table is the Stoa of Attalos at Athens. None of the others are proportioned for an upper storey. As can be seen, the proportions of the lower interior order of the Stoa of Attalos at Athens are lower in relation to the rest of

¹⁸¹ Coulton 1976, 121, suggests that stouter proportions for Ionic columns might also be due to the proximity of Ionic and Doric in stoas. This, however, does not seem to be the case in temple design or in other types of buildings (e.g. the Propylaea on the Athenian Acropolis, where Doric and Ionic are juxtaposed, but the proportions remain distinct, though the Ionic columns only carry ceiling beams and coffers).

¹⁸² This table is a revised version of the table shown in Coulton 1976, 120.

the group, falling under eight diameters. The difference between the South Stoa and the Stoa of Attalos ratios could be attributed to the chronological gap and the fact that the South Stoa is breaking new ground for such use of the order, where stouter proportions might have been used for the sake of safety. Conversely, the table shows that if the South Stoa did not have an upper balcony and the columns rose to the height necessary to support the rafters, the ratio of diameter to height would be ca. 1:10, which is more than the slenderest temple ratio. Even using Broneer's smaller ratio of 1:9.45 with a shorter exterior column, the South Stoa would be a radical anomaly and the Ionic columns more slender than all but three Asia Minor temples.

In other secular architectural contexts where Ionic columns are employed the proportions share close similarities with stouter columns used in multi-level stoa design as proposed here for the South Stoa. The Palaistra and Gymnasium colonnades at Olympia, constructed in the Hellenistic period, employ relatively heavy proportions for their interior Ionic colonnades. In both complexes, Ionic and Doric are directly juxtaposed and both carry the weight of the roof. The Ionic columns of the Palaistra have a lower diameter of ca. 0.51 m. with a height of 3.93 m., making the diameter to height ratio ca. 1:7. while the Doric columns are 3.41 m. tall with a lower diameter of 0.56.6 m. (6.7 D).¹⁸³

¹⁸³ See Mallwitz (1972, 279) for the Doric columns; *ibid.*, 282 for the height of the Ionic columns.

Chapter 6

Orthostates and Wall Blocks

The orthostate blocks of the two side walls of the stoa measure 1.17 m. in length, 1.05 m. in height and 0.465 m. thick.¹⁸⁴ The orthostates are slightly thicker than the wall blocks, projecting ca. 0.008 m. on either side of the wall. Orthostates of the back wall and the interior rooms differ in length, averaging 1.24 m. instead of 1.17 m.

There are two wall blocks preserved in situ at the east end on the north side of the front wall of the backrooms. At the west end of the building no wall blocks are in situ in front of the backrooms. Several courses are preserved at various points behind the front wall of the backrooms, however. The thickness of the normal wall blocks is ca. 0.45 m. The height of the preserved examples is 0.525-0.545 m. +/- 0.01 m. and the length is ca. 1.17 m., though there is slight variation in lengths.¹⁸⁵ The walls were finished with stucco on the interior, while the exterior surface was left rough except for a lower beveled edge.¹⁸⁶ Using ten wall blocks of 0.54 m. in height plus an orthostate of 1.05 m. in height would equal 6.45 m. in height ($[0.54 \text{ m.} \times 10] + 1.05 \text{ m.} = 6.45 \text{ m.}$), which falls within the range of the theoretical Doric column height arrived at above.

¹⁸⁴ Broneer 1954, 39.

¹⁸⁵ Broneer 1954, 40, Figs. 19, 20, 27, 28, 29. If an ancient foot of 0.30 m. was used for the blocks, then $0.54 / 0.30 = 1.8$ feet (see discussion of the ancient foot unit below).

¹⁸⁶ Broneer (1954, 40) is not clear which edge was beveled; he assumed that the intention was to remove the rough surface down to the level of the beveled edge.

Range of Preserved Wall Block Heights

0.545 m.
 0.530 m.
 0.545 m.
 0.525 m.
 0.525 m.
 0.533 m.
 0.531 m.

Wall Antae

The east and west side walls terminate in antae whose toichobate lies 1.24 m. directly behind the back edge of the stylobate of the corner columns of the front colonnade. The foundations indicate that the antae were slightly more than twice the width of the normal wall blocks ($0.45 \text{ m} \times 2 = 0.90 \text{ m.}$) based on the fact that the two foundation blocks between the front colonnade and the beginning of the side walls are the same width as the stylobate blocks under the corner columns (1.08 m.). No anta block for this position has been found.¹⁸⁷ It is possible, however, to restore the dimensions of the anta based on indirect evidence. The reason for making the antae wider was the necessity of carrying the entablature at the corner from the front to the sides of the building. **Fig. 64** and **Fig. 65** The thickness of the anta return must sit inside the north edge of the toichobate and it must extend back enough to allow the return of the entablature to line up at its back edge. The frieze, then,

¹⁸⁷ Broneer 1954, 19, 22, 39, 40. Broneer found one block that he thought was a possible anta capital for the end of the wall (Fig. 16), recovered from well XXII, but this anta capital appears to be half as thick (0.246 m.) as it needs to be and as it is shown in the reconstruction (Plan XIVb). Broneer (1954, 39) calculated that “the L-shaped projections forming the antae probably had the same thickness as the walls” due to the fact that the “tooling and weathering seem to indicate that the eastward bend forming the anta was only ca. 0.47 m. thick.” The tooling and weathering are no longer visible and no photographs or drawings seem to exist to substantiate these remarks.

provides the dimensions, as the corner triglyph (0.45 m.) plus a frieze length of 2.34 m. carries the entablature to the back edge of the anta if it is 0.47-0.49 m. thick. If the orthostate for the anta rests slightly behind the north edge of the toichobate, it would need to extend southward ca. 0.50 m. Since the orthostates project beyond the wall thickness by 0.01 m., the anta wall blocks would have a thickness of between 0.47 to 0.48 m. The crowning molding for the anta is not known but can be tentatively restored on analogy with late 4th/early 3rd century moldings elsewhere at Corinth, in which case it should consist of a Doric hawksbeak.¹⁸⁸

Prostyle Colonnade

The prostyle arrangement of the South Stoa at Corinth, with side walls terminating behind the colonnade, is not unheard of in stoa architecture, but it is somewhat rare.¹⁸⁹ An in antis end condition is more normal. Coulton has pointed out that the prostyle façade might be seen as a Corinthian preference.¹⁹⁰ Before the Roman period, it occurs three times at Corinth, in the small stoa by the Peirene Fountain, the Hellenistic North-West Stoa and once at Perachora in the L-shaped Stoa by the harbour. In the Peloponnesos, there are three other documented cases: the Stoa by the Bouleuterion at Sikyon, the Abaton at Epidauros and Stoa J at Kalydon. While outside the Peloponnesos, only three other examples exist: the West Stoa in the Asklepieion at Athens, Building II in the Agora at Thasos and Stoa J at

¹⁸⁸ This type of projecting anta is paralleled in the small hexastyle stoa next to the Peirene fountain (see Hill 1964, 51 and Pl. VI), where it served the same function with a prostyle colonnade.

¹⁸⁹ Coulton notes "in all periods it was normal for the main façade of a stoa to be occupied by a long colonnade in antis" (1976, 80).

¹⁹⁰ See Coulton 1976, 80.

Samothrace. Although the number of stoas with prostyle colonnades in the Peloponnesos is not overwhelming, the fact that seven (including Perachora) occur there and three at Corinth would imply a regional preference and the fact that three occur at Corinth lends weight to the idea of the prostyle colonnade being a Corinthian building practice. In addition, Epidaurus had definite ties to Corinthian builders at this time, and Sikyon, which is close by, almost certainly shared connections as well.

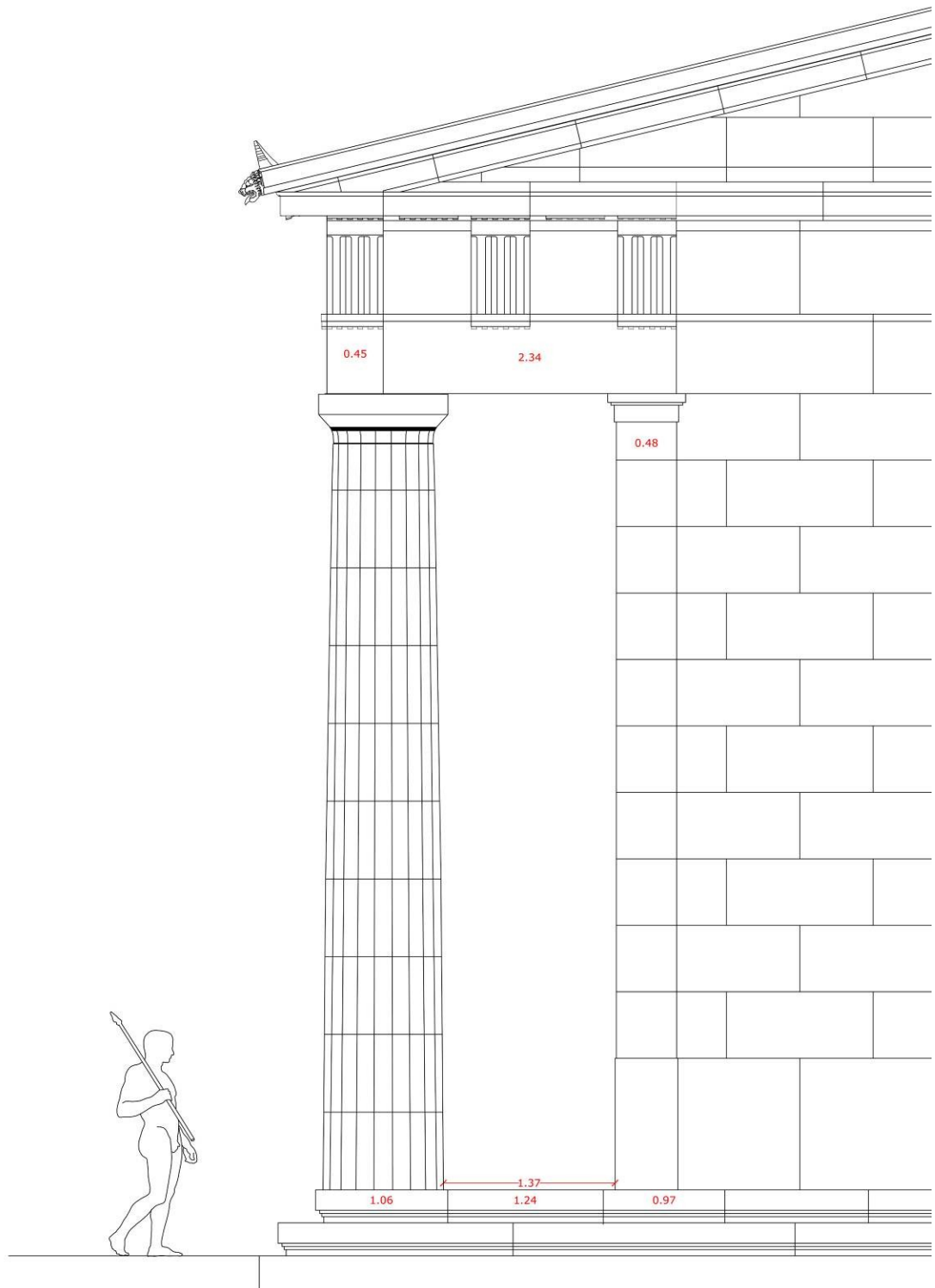

Fig. 64. Elevation of west end showing principal dimensions affecting the anta. Hypothetical restoration with frieze turning the corner and ending over anta.

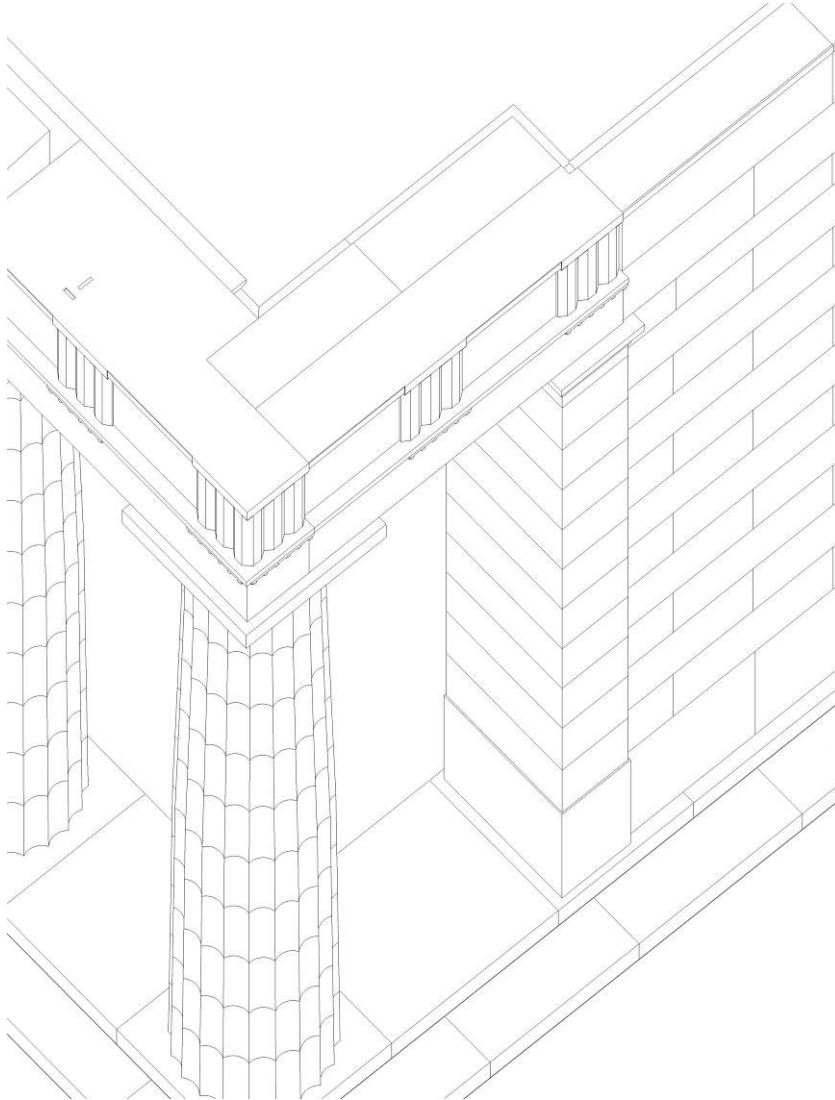

Fig. 65. Isometric view of anta condition showing transition from corner column to wall.

A prostyle façade does not have a visual termination as would be the case with an *in antis* arrangement.¹⁹¹ Moreover, the prostyle arrangement creates an additional design problem. By bringing the colonnade to the end, a discrepancy arises between the thickness of the entablature and the wall thickness where the two meet. (See above **Fig. 31**) In an *in antis* arrangement the entablature and the wall meet at a ninety degree angle, so any difference in thickness would not matter. In a prostyle arrangement, the entablature must

¹⁹¹ For Coulton's remarks on this distinction (1976, 80).

return along the sides to the anta and, if the entablature and wall are not of the same thickness, a jog in the wall results where the two meet. As Coulton has pointed out, at Perachora, the problem exists because the upper entablature must be thinner than the wall in order to rest on the abacus of the Ionic columns, but where the wall and entablature meet, the wall must be offset inward to line up with the entablature so that the pediment has a sufficient resting surface at the corner.¹⁹² In the South Stoa at Corinth, the opposite problem exists, since the entablature thickness is twice that of the wall thickness. In the South Stoa, the problem is handled in a somewhat elegant way by having the wall terminate in an L-shaped anta, whose thickness is equal to the entablature. The entablature is then allowed to return with its full thickness to the back edge of the anta. This design feature also supports the notion that the entablature terminated at the back edge of the anta, unless a thinner entablature continued on top of the wall.

¹⁹² Coulton 1964, 119.

Chapter 7

Entablature



Fig. 66. Section showing principal dimensions of the Doric order of the façade.

On the exterior, a Doric entablature, consisting of an architrave course with regulae and guttae, and a frieze course of triglyphs and metopes, rested

on the Doric columns of the façade. **Fig. 66** The entablature was carried around both sides, stopping at the back edge of the antae.¹⁹³

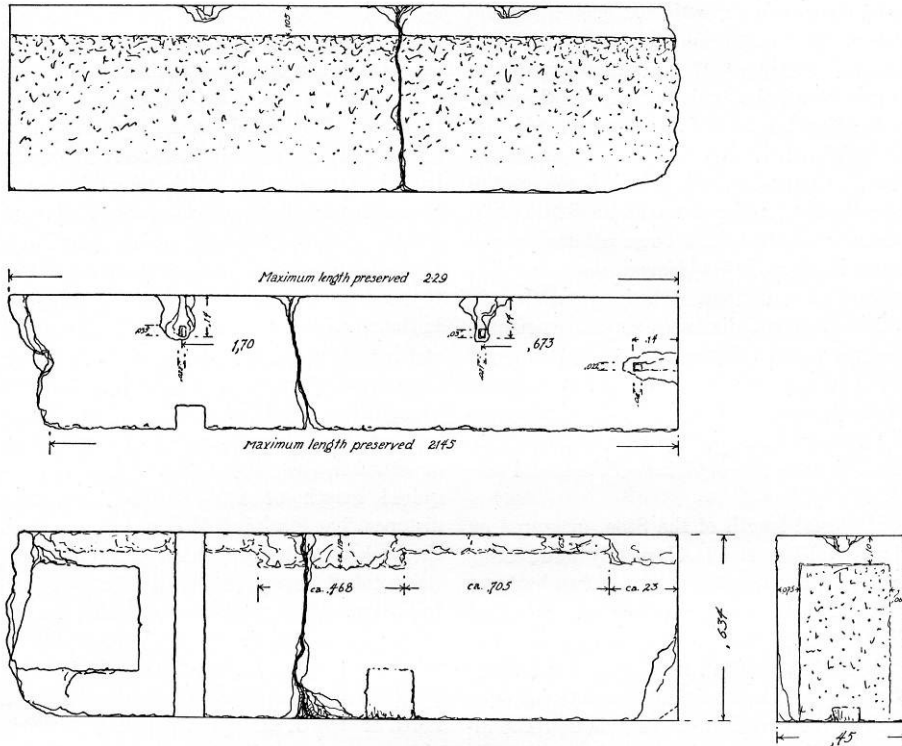

Fig. 67. Joining fragments of architrave (Broneer 1954, Fig. 10).

Architraves

No complete epistyle block remains. One block 2.14 m. in length and another two joining fragments measuring 2.29 m. in length were found built

¹⁹³ Broneer (1954, 40) carried the entablature along the sides of the building. His argument for this is that the lengths of the wall blocks on the sides follow the same modular system as the entablature on the front. There is also one block, which he restored as a single metope with a reduced thickness to sit above the wall, which would indicate that the frieze continued along the sides. The wall block length is 1.17 m. because this was a standard unit of length in the construction of the building and the block restored as a metope is actually a wall block with a taenia the same height as the metopes but reduced in depth (see below), indicating it belongs at the frieze level as a continuation of the course along the sides and probably the back as well.

into the late wall in front of the backrooms, while another small fragment preserving a regula with a gutta was also found.¹⁹⁴ **Fig. 67** Both of the larger blocks preserve only traces of the taenia and regulae, which have otherwise been chiseled off, making it possible to measure their dimensions based on the rough edges where they once projected. For both blocks the regulae have a width of 0.467-0.468 m. The space between regulae measures 0.705-0.706 m. That would make a frieze unit of 1.172-1.174 m. and doubling that, the full length of an epistyle block would be ca. 2.34 m., the interaxial distance. The height, which is preserved, is 0.634-0.635 m. The full thickness of the epistyle at the bottom is ca. 0.90 m. with the backers. At the top, the full thickness is 0.946 with the projecting taenia. From the smaller fragment, the measurements of the taenia and regulae are preserved. The taenia is 0.062 m. in height and projects 0.046 m. The regula is 0.04 m. in height and projects 0.041 m. The guttae are 0.023 m. in length and have a diameter of ca. 0.04 m. measured at the base.¹⁹⁵

¹⁹⁴ See Broneer 1954, 33 and plate 8.3, 4, 5. The following dimensions and description are based in part on Broneer with supplementation by the author. The two joining blocks were remeasured and redrawn by the author.

¹⁹⁵ The small fragment preserving the regula and gutta also has traces of Roman stucco and red paint on the taenia (Broneer 1954, 34). The measurements, however, are irrespective of the thickness of Roman stucco which is only on the face of the taenia. The regulae and guttae would be conical so the end diameter would be slightly larger.

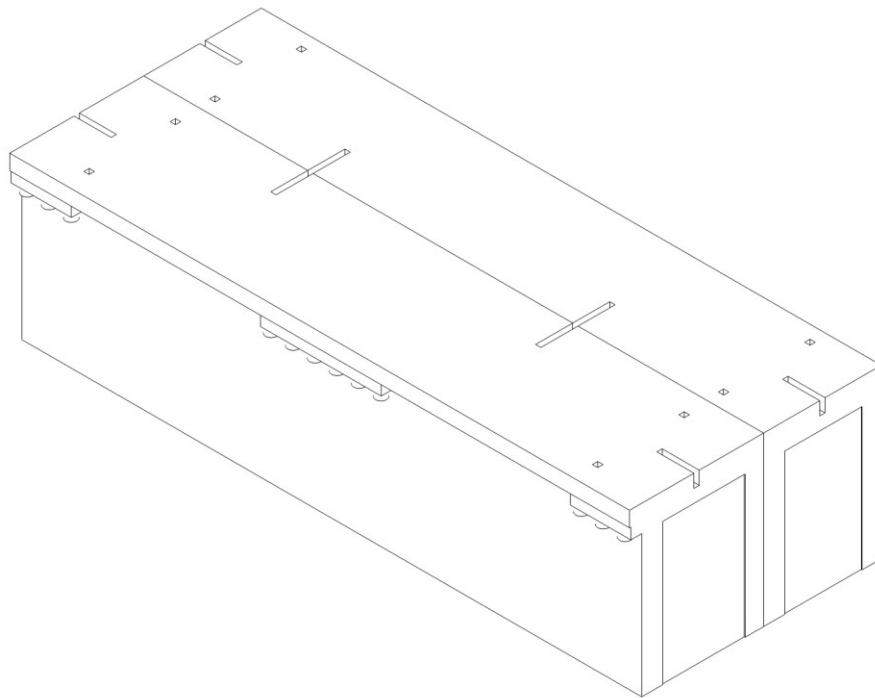

Fig. 68. Isometric of architrave of the north façade with backer restored.

The preserved epistyle blocks have cuttings for hook clamps on the upper surface at the ends of the block and two clamps spaced 1.07 m. apart at the back of the block. The ends and back of the blocks have anathyrosis with margins 0.10 m. at the top. The ends of the blocks have margins of 0.065-0.075 m. on both sides. On the bottom ends of the block are pry cuttings.

The “normal” epistyle blocks measure 2.34 m. in length, 0.634-0.635 m. in height and ca. 0.45 m. in depth at the bottom.¹⁹⁶ **Fig. 68** Each architrave would have had a backer of ca. 0.45 m. thickness, to which it was joined by hook clamps, although no backers have been found. The combined thickness

¹⁹⁶ Broneer 1954, 33-34 and Fig. 10.

of both blocks would have been equal to the frieze thickness, 0.90 m. If the total thickness is 0.90 m., the abacus of the Doric capitals would project ca. 0.065 from the front and back of the architrave.¹⁹⁷ The preserved blocks of the epistyle do not have traces of setting lines for the frieze, but normally in Doric design the outer faces of the triglyphs would align with the face of the epistyle below the taenia.

Corner Condition of Architrave Blocks

Since the thickness of the front facing blocks was half the frieze thickness, the front block of the architrave could extend to the end of the corner and a separate architrave, exactly 2.34 m. in length, could return along the side from the back edge of the front facing block to the L-shaped anta.

Fig. 69

¹⁹⁷ If the measured lengths of 0.468 m. for the regulae represent the “true” lengths of the regulae, then the regulae are 0.018 m. wider than the theoretical triglyph width of 0.45 m. arrived at by Broneer, making the regulae project 0.004 m. to either side below the triglyphs. Either there is a degree of variability in triglyph widths to account for this discrepancy or the triglyph width should be understood as 0.468 m. The former seems more probable. Normal Doric design calls for regulae to be the same length as the triglyph width. The overall spacing of the regulae as measured indicates a triglyph/metope unit of 1.172-1.174 m., 0.002-0.004 m. more than the theoretical unit of 1.17 m. set by the interaxial distance. When this is doubled, the maximum discrepancy is 0.008 m. This should probably be understood as within tolerances. Broneer (1954, 34-35) discussed this discrepancy and noted that where the triglyphs overlap metope ends the amount would be made up.

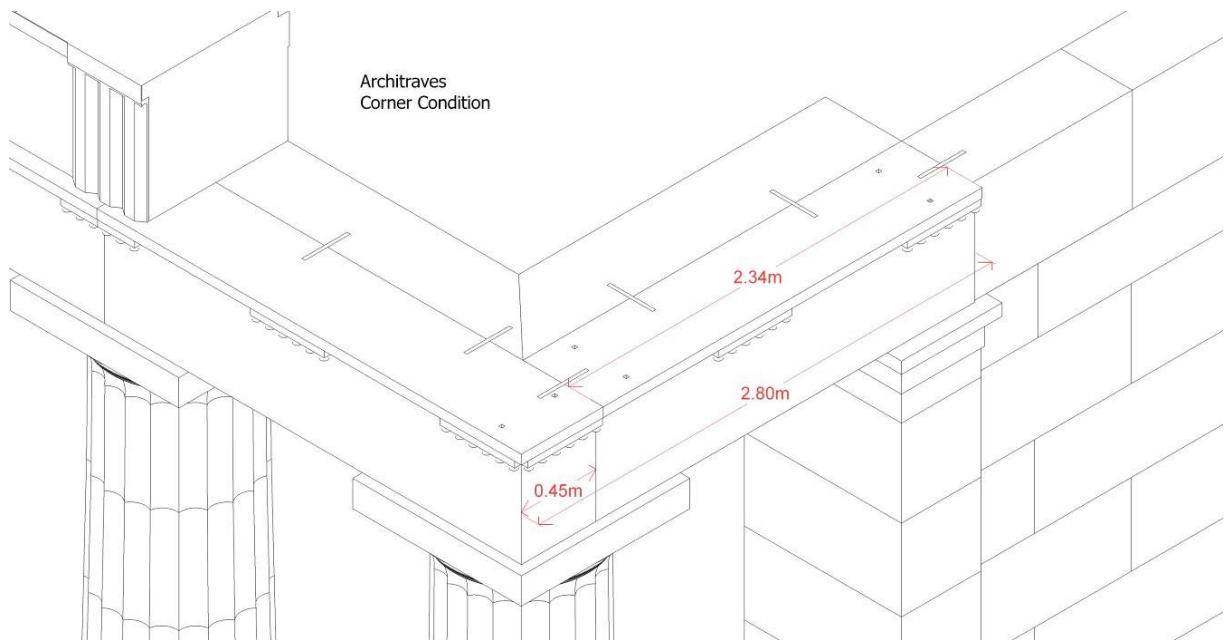

Fig. 69 Perspective showing architraves meeting at the corner and returning to back edge of anta.

The architrave backer blocks, then, would meet on the diagonal at the corner and the backer above the anta could be cut to a maximum length of 2.34 m. resting with its back edge just in line with the anta below.

At the front corner, the architrave would need to be 2.57 m. in length, instead of 2.34 m., to reach the line of the flanks.¹⁹⁸ With a height of 0.634-0.635 m., the architraves are 0.66 times the lower column diameter, falling within the normal ratio for mainland Greece. Lower architraves are considered an East Greek phenomenon.¹⁹⁹

Frieze

¹⁹⁸ Corner contraction is half a triglyph, or ca. 0.225-0.234 m., requiring the addition of half a triglyph to bring the architrave in line with the edge of the frieze above (or this can be described as 2.34 m. – 0.225 m. [contraction] + 0.45 m. [triglyph] = 2.565 m.).

¹⁹⁹ See Coulton 1976, 109.

Nine fragments of frieze blocks are preserved. Three frieze blocks preserving their full length of 2.34 m. were built into the late wall in front of rooms XXII-XXIV. Five more fragments were found by Broneer near the east end of the building.²⁰⁰ All that is preserved of the triglyphs are ghost impressions left on many of the blocks, where the triglyphs were cut away flush to the adjacent surface.²⁰¹ **Fig. 70** and **Figure 71** It is assumed that the South Stoa triglyphs are of the Peloponnesian type, where the top of the groove of the channel can be either straight or slightly curved at the corners. The sides terminate in a corresponding half groove.²⁰²

²⁰⁰ This wall, which is on top of the front wall foundations of the backrooms, was probably constructed in the 5th or 6th c. A.D.

²⁰¹ Broneer (1954, 34) mentions a “nearly complete triglyph” fragment, but this must refer to the ghost impressions as not even a partial triglyph is preserved. It is interesting that so much effort would be expended to remove the triglyphs and regulae on blocks that were for re-use in a rough late wall, unless the wall was prominently visible and the late use of the stoa backrooms was not an entirely haphazard endeavor. It certainly means that by this time the front colonnade had been dismantled.

²⁰² In comparison to the Attic type with ears. See Coulton (1968, 172-173) on this distinction.

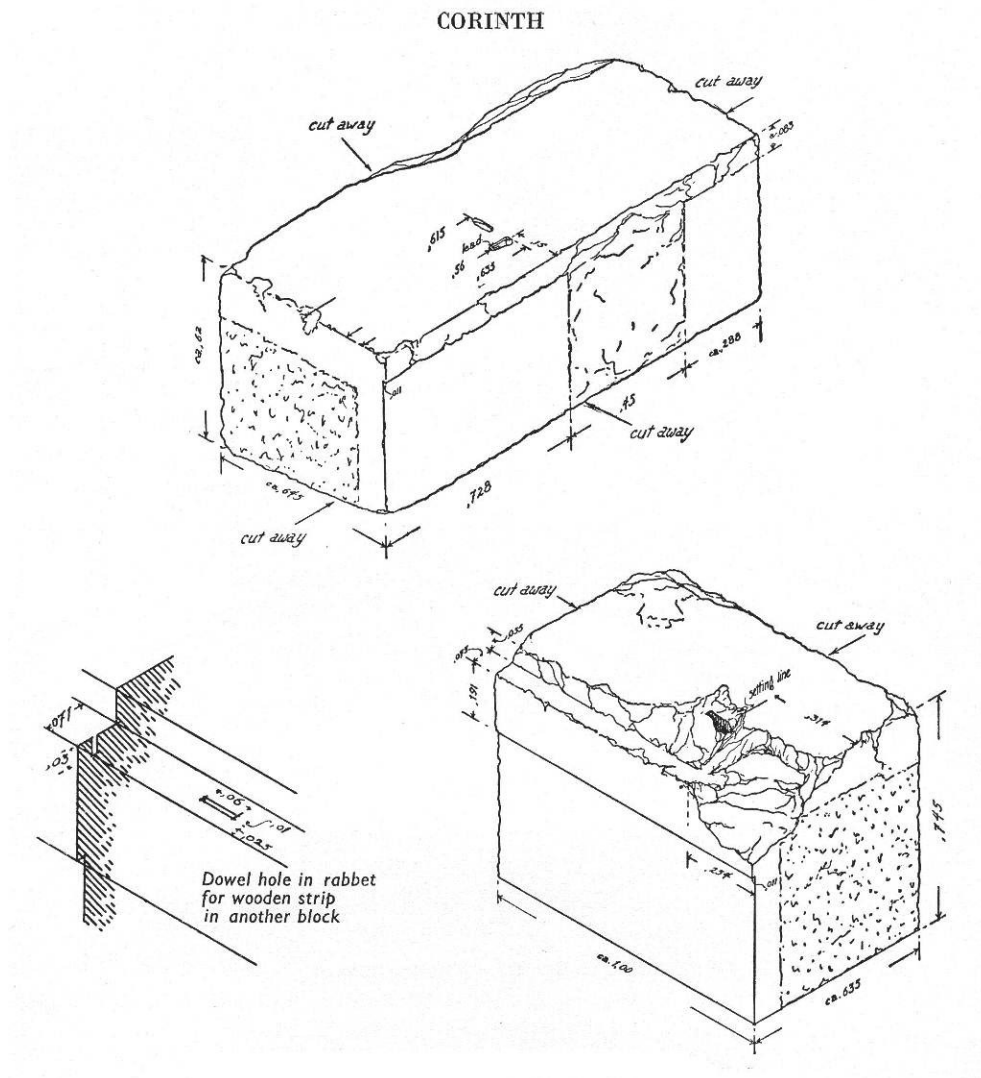

Fig. 70. Two separate fragments of Doric frieze. At top, view of front with missing triglyph. Bottom right, back view with taenia and rebate, shown in detail at left (Broneer 1954, Fig. 12).



Figure 71. Frieze block shown in Fig. 70 at top.

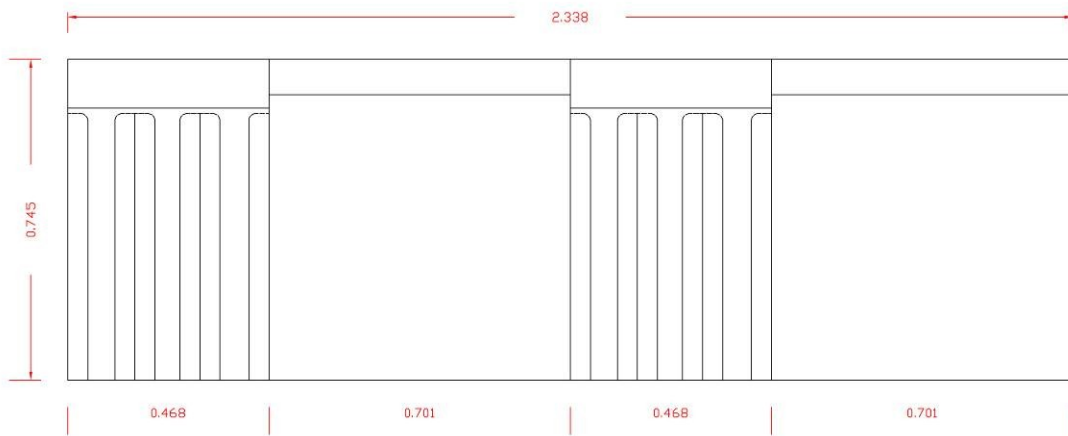

Fig. 72. Doric frieze block of the façade with principal dimensions, restored.

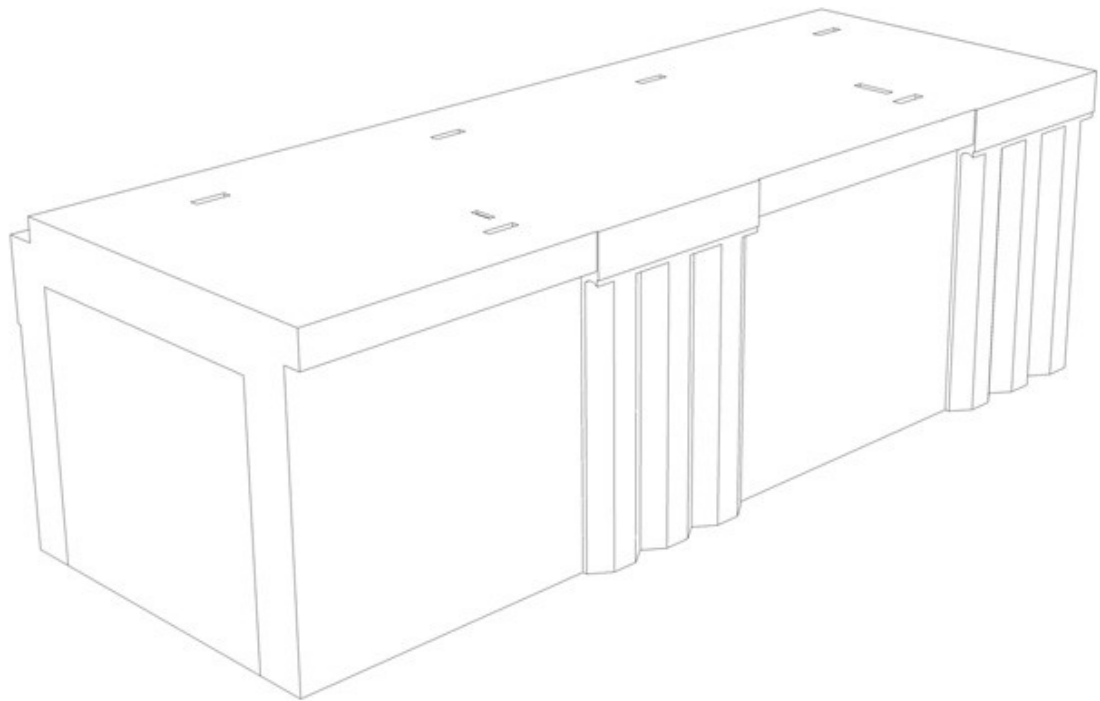

Fig. 73. Restored perspective view of frieze block.

The frieze blocks of the Doric façade are made up of two triglyphs and two metopes and, like the architraves, are 2.34 m. in length. **Fig. 73** Their

height is 0.745 m. and measured thickness is 0.90 m., which is the full thickness of the architraves with backers.²⁰³ **Fig. 66** This would have presumably been done to add compressive strength to the entablature, and has the effect much like the coursing of headers and stretchers. The width of the triglyph can be extrapolated from the width of the regulae on the architrave and the width of the mutules of the geison. The regula width is 0.468 m. as measured on the preserved architrave. The mutule width as measured on a normal geison of the front is ca. 0.460 m. and the mutule width as measured on the corner geison block is 0.450 m. The attested variation in regula and mutule widths is therefore 0.450-0.468 m.²⁰⁴ The regula width of 0.468 m. is exactly the width necessary for the triglyph if the intercolumniation were calculated using the method for peripteral temples where the intercolumniation (2.34 m.) equals five times the triglyph width (0.468 m.).²⁰⁵ Thus the standard metope width would be ca. 0.702 m. ($0.468 + 0.702 = 1.17 \times 2 = 2.34$). The metope width in this scheme is 1.5 times the triglyph width, precisely the ratio recommended by Vitruvius.²⁰⁶ It might be assumed based on the width of the corner mutule size that the corner triglyph has a slightly shorter width (0.45 m.) than the rest of the triglyphs (0.455-0.468 m.), however, given the lack of available data, it is impossible to say for certain.

²⁰³ Three blocks made up of two triglyphs and two metopes exist, reused in the late wall constructed on top of the front shop wall foundations. The lengths of these three frieze blocks are 2.33 m., 2.34 m., and 2.34 m. See Broneer 1954, 34.

²⁰⁴ Broneer (1954, 34 and Fig. 12 top) restores the triglyph width as 0.45 m. based on ghost impressions left on the face of a surviving frieze block, but this contradicts his own measurements for the regulae, which are 0.468 m. in width. In Doric design, the width of the regulae and the width of the triglyphs should be the same.

²⁰⁵ See Coulton 1974, p. 63.

²⁰⁶ See Vitruvius (De arch. 4) on 2:3 ratio of triglyph and metope; for current discussion of this ratio see Wilson Jones 2001.

The difference, which amounts to 0.018 m., could have occurred along the frieze course near the corner with a corresponding variation in the geison.²⁰⁷

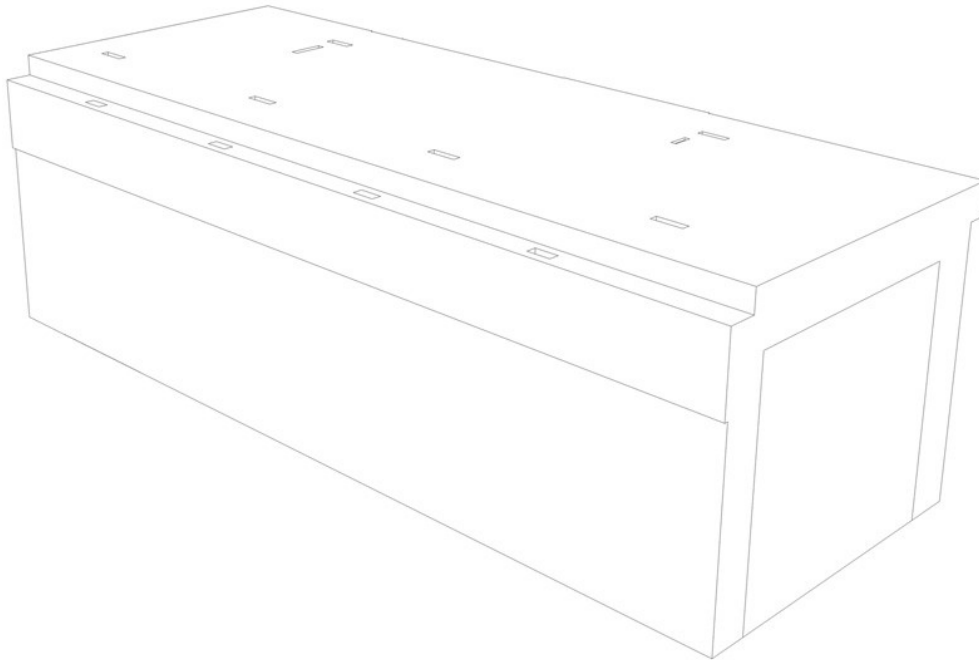

Fig. 74. Restored perspective of back of frieze block, showing rabbet along upper edge for wooden molding strip.

At the top back of the frieze blocks there is a cutout for a wooden strip that was doveled to the block. **Fig. 74** This strip may have been either to cushion the rafter ends where they rested at the back edge of the frieze block or a horizontal tie beam running from the frieze back to the interior colonnade. Structurally, the front colonnade would have benefited from tie beams in this position to stabilize the outward thrust of the roof (see **Fig. 80** and **Fig. 81**).²⁰⁸

²⁰⁷ Broneer (1954, 36, Fig. 12) does show a frieze block with a trace of the triglyph edges measured to be 0.45 m. in width. Due to further weathering of the block, I have not been able to see the traces well enough to measure them with precision.

²⁰⁸ See also 148 and fn. 180 below. Also see Hill and Williams (1966, 15-16 and Fig. 3) for similar use of dowels which they postulate were to secure a horizontal tie beam.

Broneer restored the frieze blocks balanced over the columns, thus breaking the joints almost in the middle of the architrave, which he assumed was to make the frieze blocks cantilevered.²⁰⁹ **Fig. 75a** The issue of cantilevered blocks in Greek architecture is problematic.²¹⁰ The blocks would actually be supported by a uniformly distributed epistyle, so there cannot strictly be a cantilever in the course above the architrave. For the frieze blocks to act as cantilevers, in any case, they would need to have recessed areas at both ends so that only the middle made contact directly above the columns. There is no evidence that the frieze blocks in the South Stoa were trimmed underneath to accommodate their use as cantilevers.²¹¹

Coulton suggested that the frieze blocks probably spanned the intercolumniation above the architraves and would not have been cantilevered.²¹² To elaborate on this point, this would mean that the frieze blocks are offset half a triglyph width on either end of the architrave blocks. **Fig. 75b** This offset method is very similar to the offset jointing used for entablatures that join the frieze and architrave together as one block, such as is done in the Temple of Asklepios and Northwest Stoa at Corinth.

²⁰⁹ Broneer 1954, 35-36.

²¹⁰ Dinsmoor seems to have been the first to propose the idea that the Greeks employed cantilevering, which he discovered in the Propylaia on the Acropolis in Athens (see especially Dinsmoor 2004, 171, 173, 176, 288).

²¹¹ In some sense, if horizontal curvature extended up to the frieze course, the blocks would be cantilevered.

²¹² See Coulton 1976, 145-146, for a list of stoas that apparently employ this cantilever technique for the frieze course, noting that the technique can be seen in stoas beginning in the 4th century. Its use can be traced in other buildings as early as the 5th c., although these are in marble, which has more tensile strength (see Dinsmoor *ibid.* for the Propylaia on the Acropolis in Athens).

a)

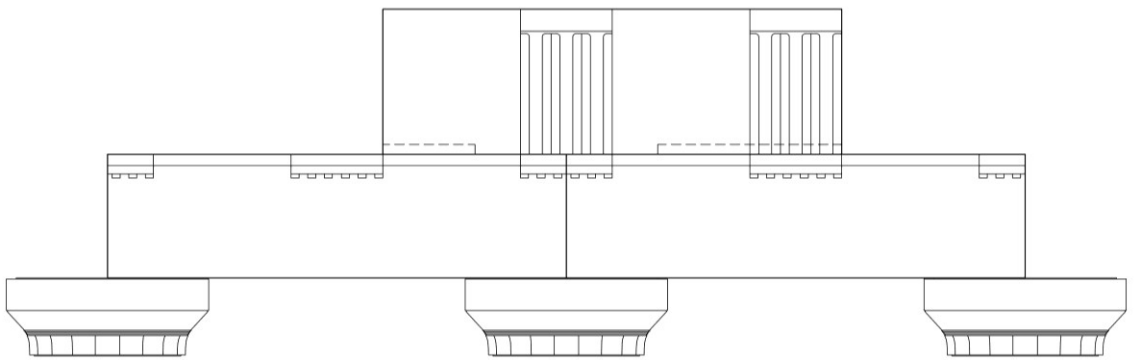

b)

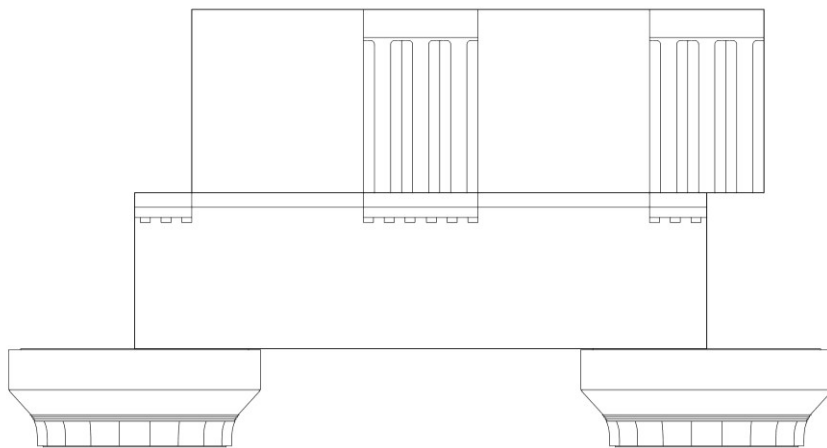

Fig. 75. a) If the frieze is cantilevered as Broneer suggested. b) More probable scheme with frieze blocks offset above the architrave.

This would seem to make more sense, as the compression strength of limestone is stronger than the tensile strength and on these grounds alone the cantilever idea is less desirable.

Therefore, it is perhaps more likely that each frieze block, being 2.34 m., like the architrave, would have spanned the intercolumniation with half a triglyph (0.234 m.) resting on the next architrave. In this way the load was transferred down through the total thickness of the entablature to the columns. It is possible that the frieze blocks were laid from both ends simultaneously with the intention to meet in the middle, in which case a block consisting of two metopes and a triglyph could have been inserted in the middle of the front colonnade as the last frieze block to be set.²¹³ **Fig. 76** Alternatively, a single triglyph is necessary if the corner solution in **Fig. 77** is adopted.

²¹³ The Temple of Zeus at Nemea uses this procedure for lowering a single metope block into place with a lewis. See Hill and Williams 1966, 13-14.

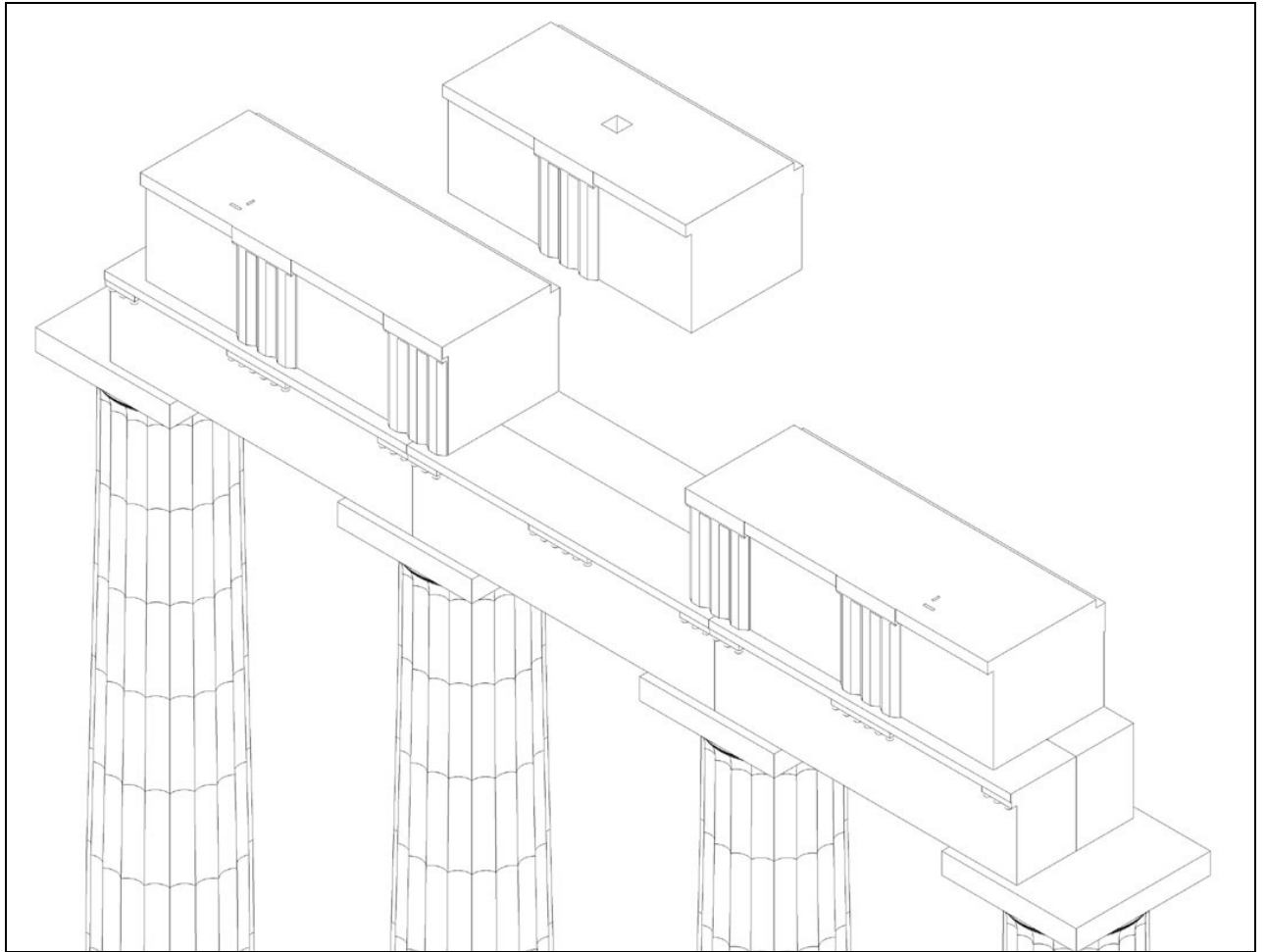

Fig. 76. Hypothetical reconstruction showing insertion of a block with two metopes and a triglyph in the middle of the north frieze after setting the normal frieze blocks starting from both ends.

The entablature was carried around to the back edge of the antae. The evidence for this is that the anta and toichobate block on which it rests are wider than the wall thickness, and the span between the anta and the corner column is exactly the length to carry a frieze of three triglyphs and two metopes from the corner to the back edge of the anta. **Fig. 77**

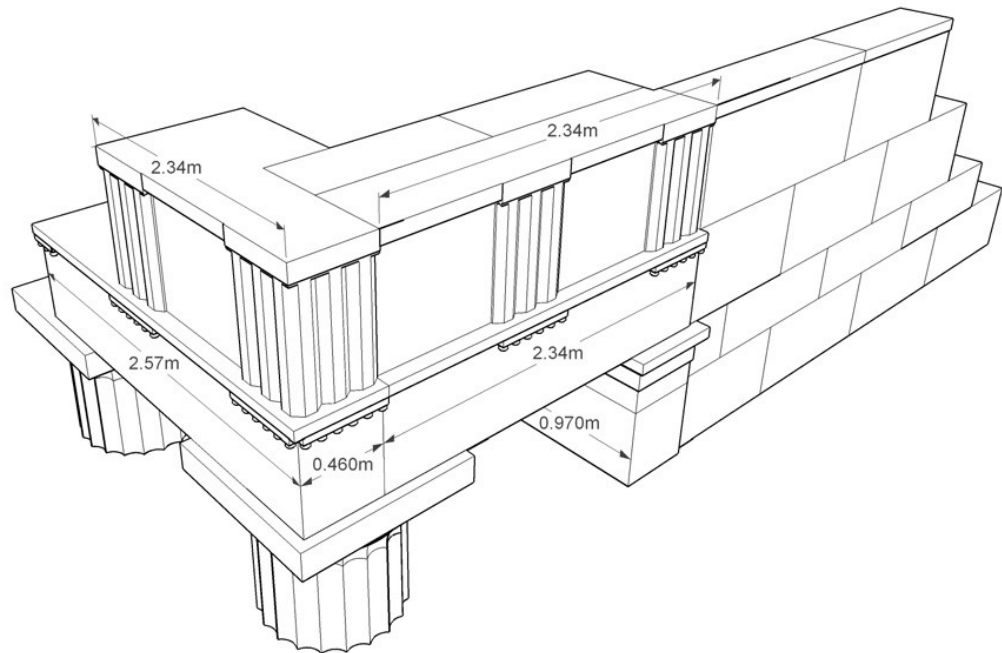

Fig. 77 Perspective showing a proposed solution for frieze blocks at the N.W. Corner.

Corner Condition of Frieze

There is no evidence that the frieze continued past the antae as Broneer envisaged, and in fact there is one piece of evidence that argues against it. This consists of a single block, which is the same height as the frieze, with a taenia at the top and recess at the back, but its thickness is the same as the wall blocks.²¹⁴ **Fig. 78** The restoration in the present study places this block on top of the wall just beyond the anta as a continuation of the

²¹⁴ See Broneer 1954, 40-41 and Fig. 17. Broneer uses this block as evidence that the frieze continued along the sides of the building, but in order to make it work as a normal metope it would have to sit back on the side wall and this would require that the wall was thicker at the level of the entablature, which seems unlikely.

frieze course. The taenia is the same height as that of the metopes, but it projects a 0.0325 m. less than the taenia of the normal metopes. When resting on the wall beyond the anta, the face is flush with the wall and the taenia is exactly flush with face of the triglyph taenia. This would indicate a vertical line break or transition from the frieze course to the wall that continues down along the back edge of the anta to the toichobate, which might be expected for a wall anta termination.²¹⁵ **Fig. 79, Fig. 80**

²¹⁵ Coulton (1968, 160) restores the stoa at the Amphiaraion at Oropos with only half a triglyph returning on the corners of the front. His reason for not continuing the frieze along the sides is that the dimensions of the sides are not in concert with those of the frieze. Contrary to Broneer's calculations, for the South Stoa at Corinth the dimensions of the sides do not follow the modular system for the frieze over the entire length. The frieze would be shy by 0.0726 m., which would have to be made up for in the length of one or more metopes and the front system is worked out such that there is no lengthening of metopes, so at least in this building there was no precedent to do so.

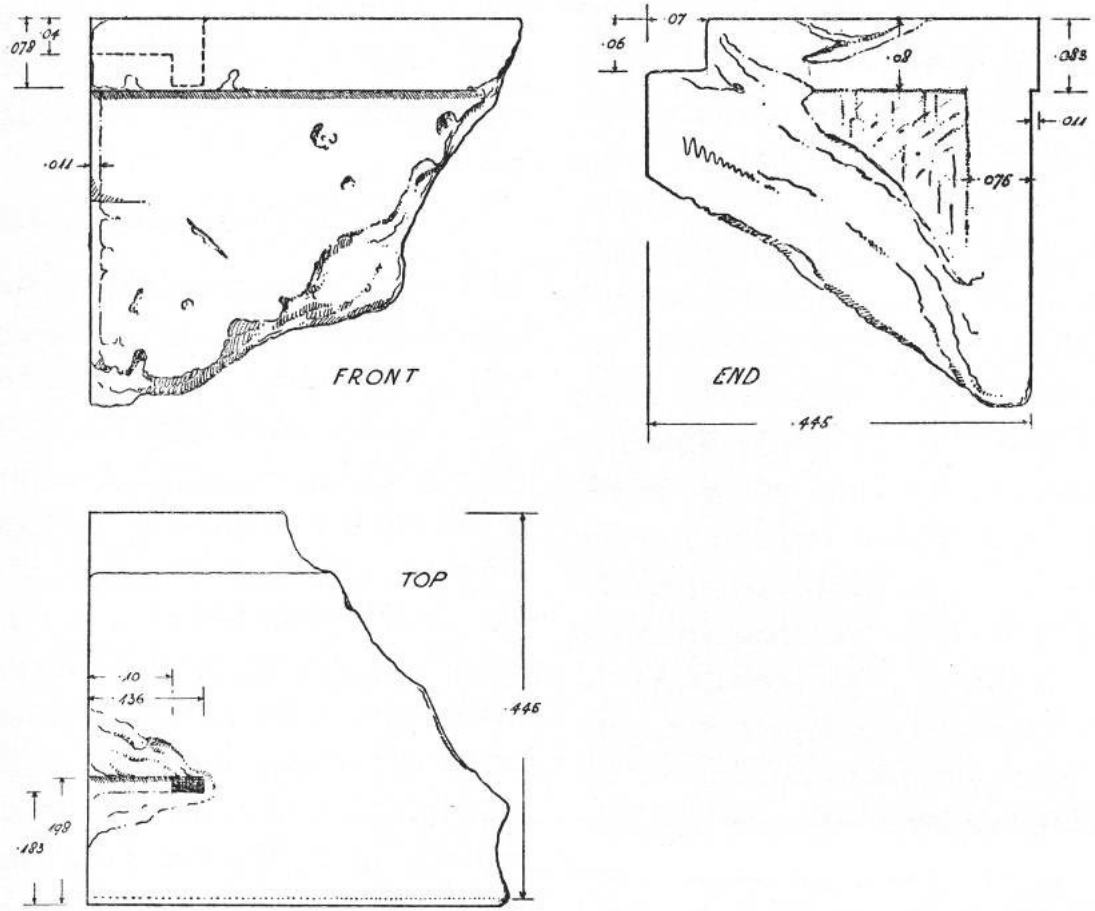

Fig. 78. Frieze block state drawing (Broneer 1954, Fig. 17).

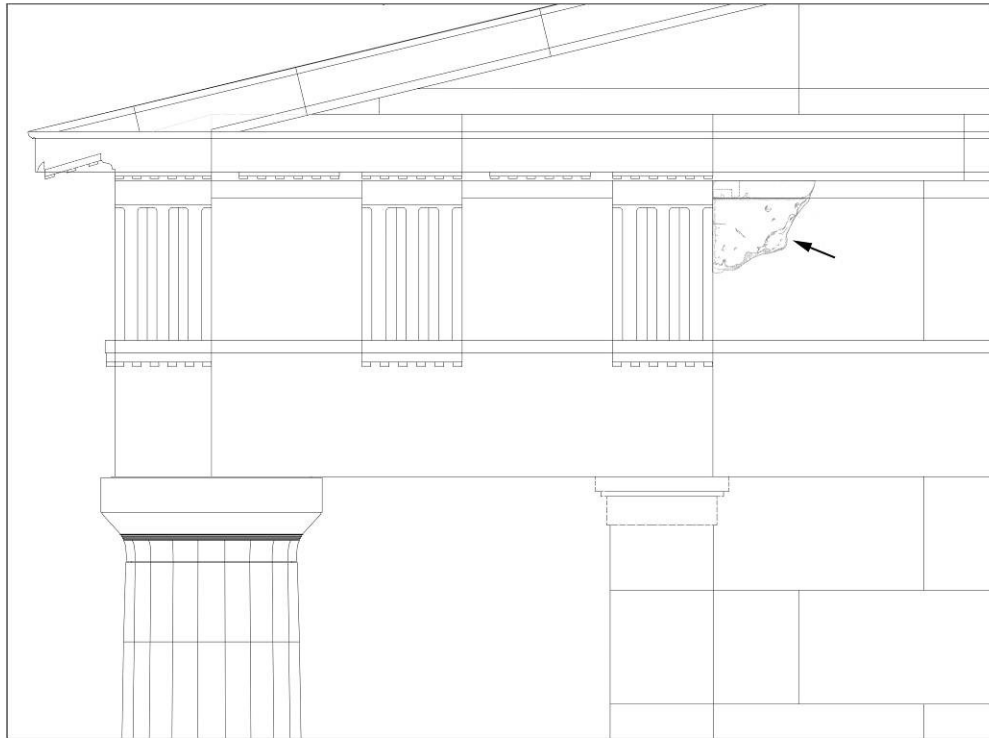

Fig. 79. Hypothetical reconstruction of position of frieze block at west end of stoa.

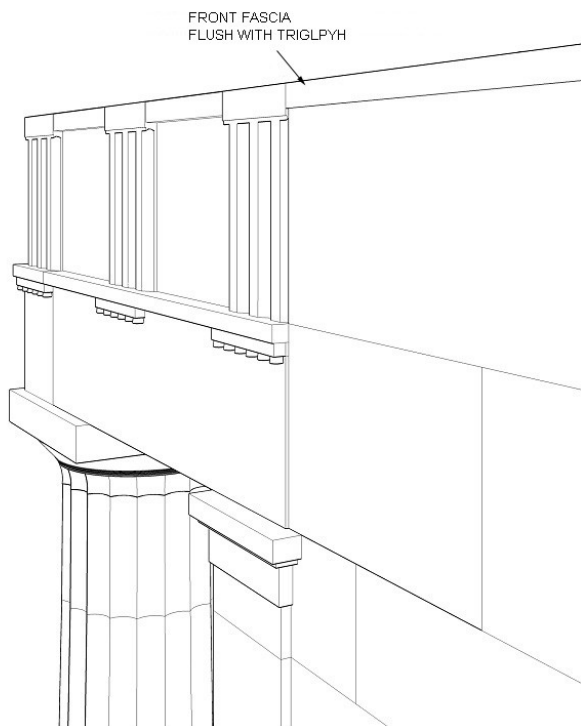

Fig. 80. Perspective of frieze block at termination of back edge of anta on west flank, abutting normal frieze on corner.

The frieze blocks preserve traces of dowel cuttings on their top surface for securing the cornice blocks above. On a few of the preserved blocks, there are the normal dowel cuttings toward the front of the block and also dowel cuttings toward the back. The front dowels would be for the cornice, which did not extend all the way to the back of the frieze. The dowels at the back of the frieze block on top would be either to secure the rafters, or alternatively there could have been horizontal tie beams below the rafters running back to the interior colonnade.²¹⁶ **Fig. 81** and **Fig. 82** There are two main reasons for assuming a horizontal tie beam existed. One, the wooden strip of molding along the top back edge of the frieze blocks perhaps finds a better purpose in conjunction with a horizontal beam, since the beam would definitely contact the back edge and the wooden strip would act as a cushion, whereas the rafters would not necessarily have rested on the back edge unless they were extremely thick. Two, a horizontal tie beam would help stabilize the colonnade against the thrust of the roof.

²¹⁶ Broneer (1954, 38) uses these dowels to suggest that some cornice blocks extended to the full thickness of the frieze. This would make the cornice unnecessarily deep and require carving out beam cuttings in the cornice blocks for some of the rafters, while other beams would sit on the frieze.

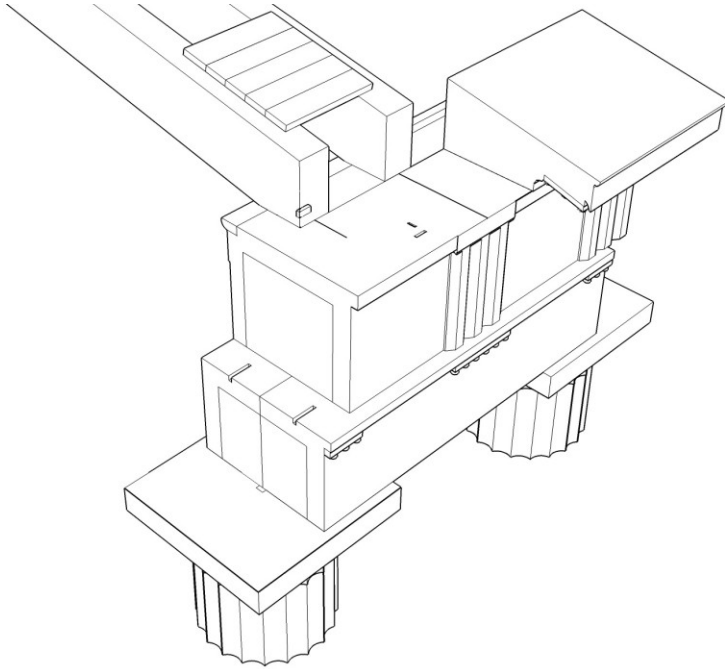

Fig. 81. Perspective of entablature with cutting on upper surface of frieze, showing dowel cutting for position of rafters and spacing of beams if without tie-beams. In this scheme rafters are ca. 0.46 m. in height.

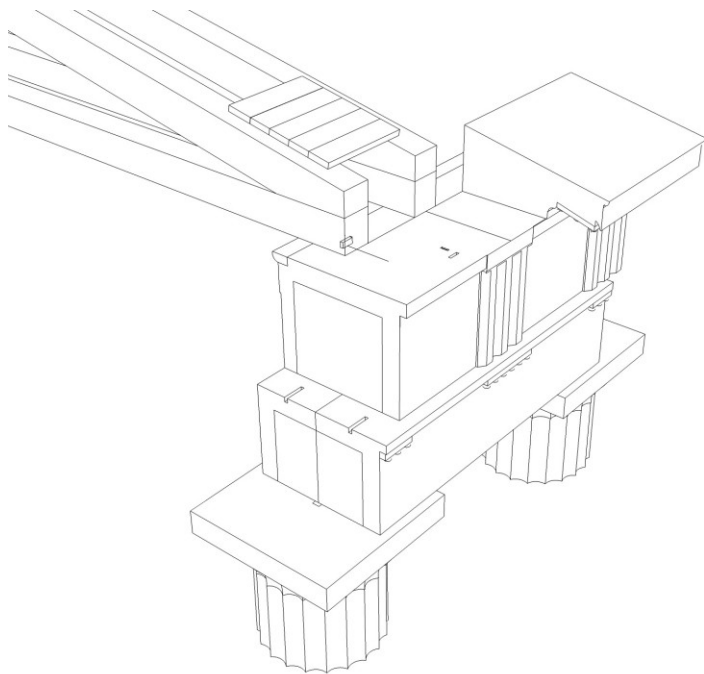

Fig. 82. Perspective of alternative rafter system, showing dowel cutting for position of hypothetical horizontal tie member and spacing of beams.

The height ratio of architrave to frieze in the South Stoa is 0.852.²¹⁷ Over the course of the 4th century the architrave to frieze ratio, in general, seems to follow a trend of becoming smaller, although there are exceptions.²¹⁸ As the Table shows, the ratio for the South Stoa at Corinth fits into the group that falls toward end of the 4th century.

Table Architrave/Frieze Height

Stoa, Amphiaraiion, Oropos	0.90	}	9/10
Temple of Amphiaraios, Oropos	0.892		
Tholos, Delphi	0.901		
Temple of Athena, Tegea	0.89		
Temple of Zeus, Nemea	0.897		
Temple of Zeus, Stratos	0.837	}	17/20
<i>South Stoa, Corinth</i>	0.852		
L-shaped Stoa, Perachora	0.847		
N. W. Stoa at Corinth	0.849		
Temple of Asklepios, Corinth	0.797		4/5

Cornice

Exterior Doric Geison/Cornice

Of the exterior Doric cornice, only fragments survive, but one cornice block preserves nearly the full back resting surface, while enough smaller fragments preserve the front corona, mutule and molding to make a restoration possible. **Fig. 83** and **Fig. 84**

²¹⁷ For the Stoa at Perachora architrave to frieze ratio is 0.847; for the N. W. Stoa at Corinth the ratio is 0.849.

²¹⁸ For exceptions, see Coulton 1968, p. 171.

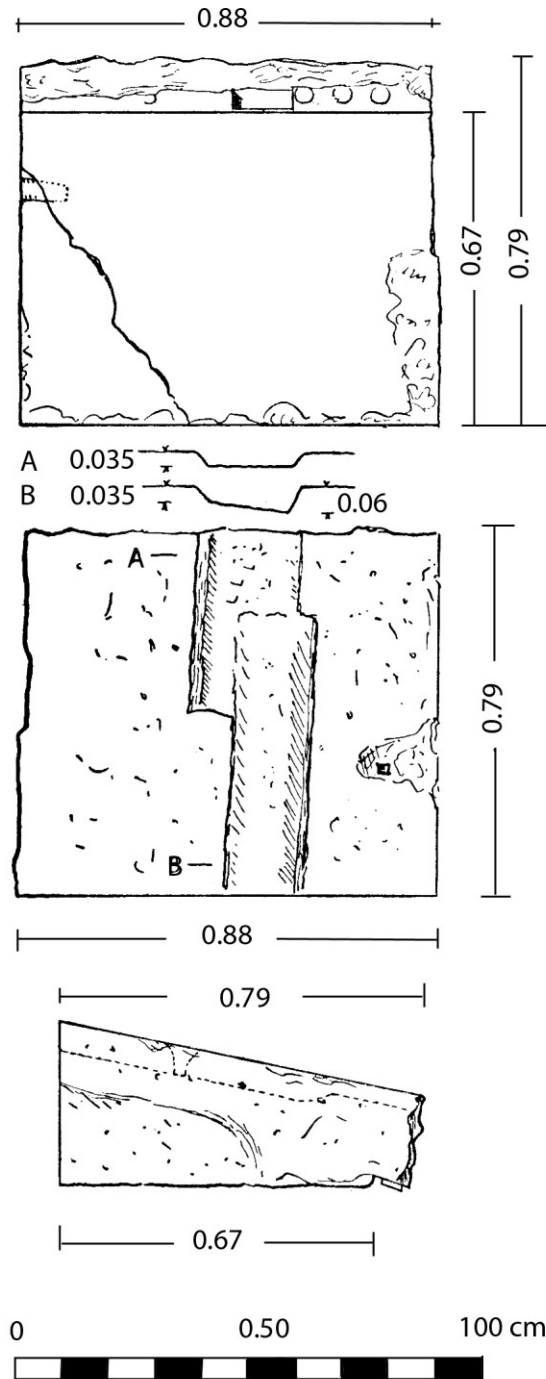

Fig. 83. Horizontal geison block from North entablature (after Broneer 1954, Fig. 14).

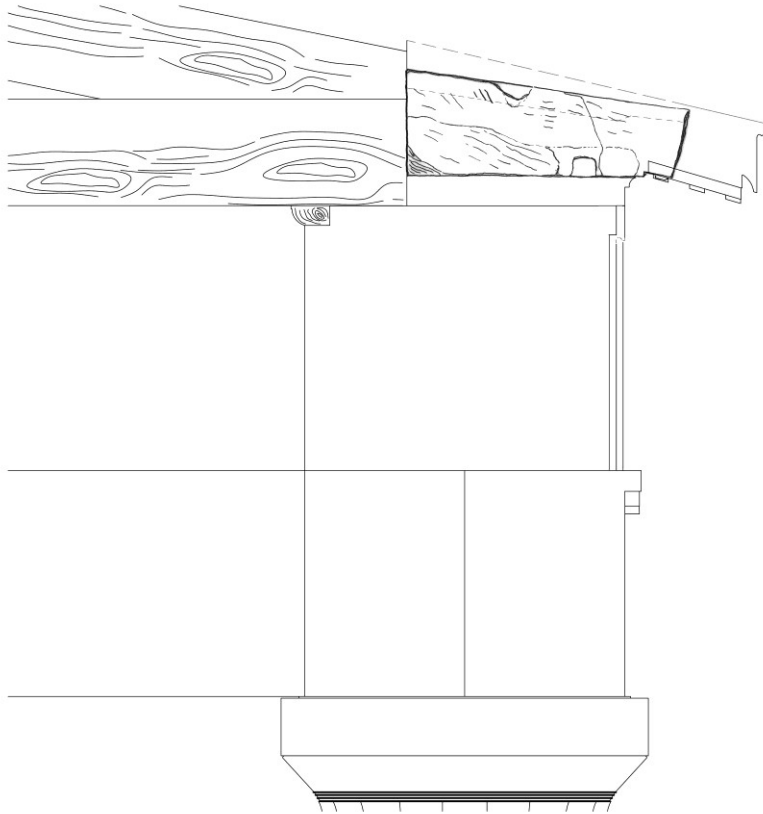

Fig. 84. Position of gison block in restored entablature.

One fragment of the corner gison exists, which can either go at the Northeast corner or at the Southwest corner of the building.²¹⁹ **Fig. 84** The block preserves the left end, upper surface and front face to the right edge of the mutule. The front profile of the gison is broken off and the back section from the mutule, including the lower molding, is entirely missing. One mutule is almost entirely preserved. Only the back corner edge and one gutta are missing. This gives the pertinent details for dimensions. The mutule is 0.45 m.

²¹⁹ See Broneer 1954, Fig. 15. He restores this block in the horizontal gable at the N.E. corner. The block is unusual in having a high sloping surface at the front of a horizontal gison block in this position, causing the pediment to have a sloping pediment floor, but it insures that the Doric façade had a pediment on the end, not a hipped roof, and that there was no upper storey façade on top of the Doric order. If the pediment did not carry sculpture, which it almost certainly did not, then a sloping tympanum would be permissible and provide a functional benefit in shedding rain water.

in width and ca. 0.27 m. in depth measured on the slope. The guttae, which are in three rows of six, are ca. 0.04 m. in diameter and project ca. 0.01 m. and are spaced front to back ca. 0.106 m. and side to side, 0.08 m., measured on centers.

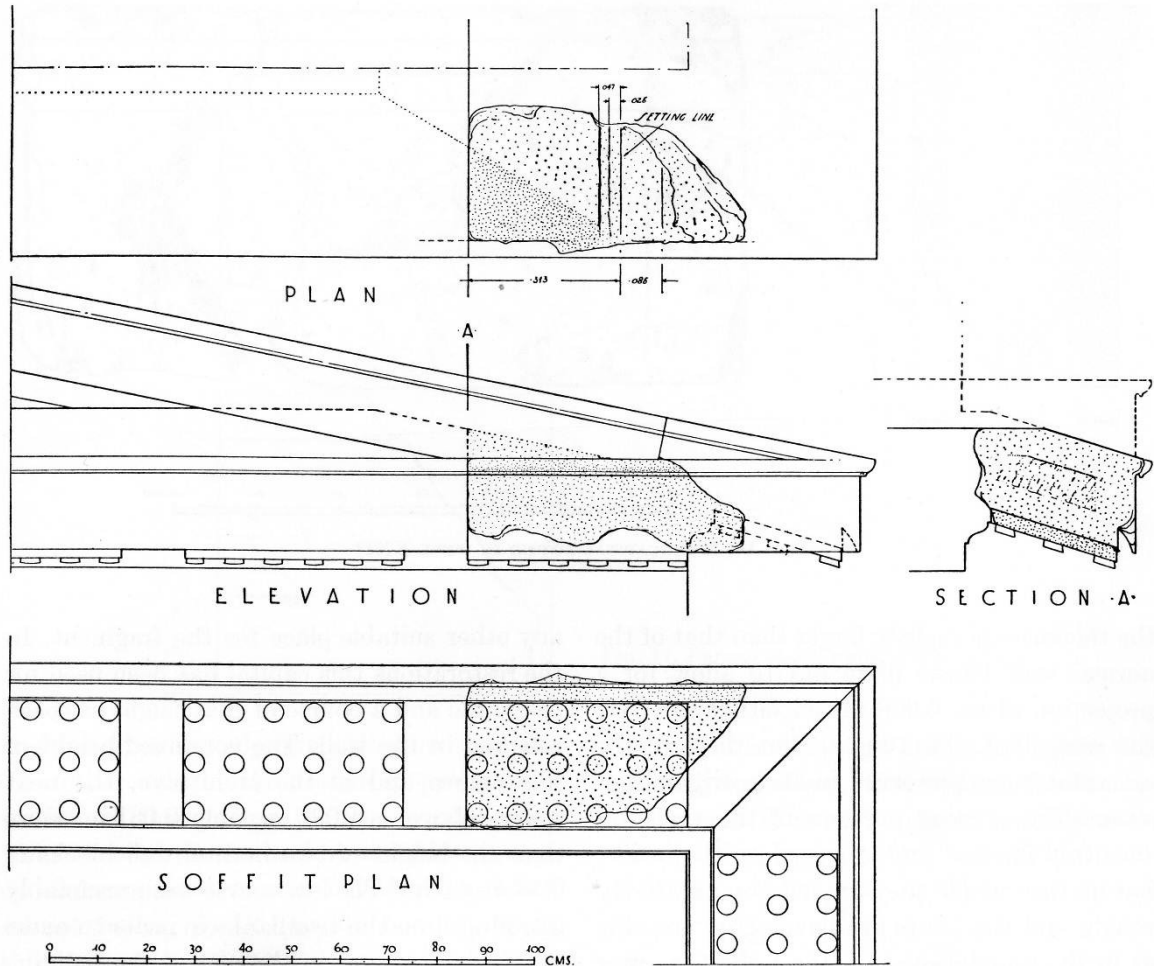

Fig. 85. Corner geison block state drawings and restored position at N.E. corner of building (Broneer 1954, Fig. 15).

Broneer correctly interpreted this block as a corner geison. The upper surface slopes to the front and right side, which has a resting surface and setting line for another block. **Fig. 86** The most telling evidence that this block is a corner geison is a small vertical ridge on the right side, which is the

beginning of what would have been the raking geison extending from the right corner, no longer preserved, which was cut from the same block. The resting surface and setting line are for the continuation of the raking geison onto the next block, which would rest on top of the sloping surface of the corner geison. The sloping surface is roughly carved with a flat chisel as though it was meant not to be seen, in contrast to the upper resting surface. From the ground below, this sloping surface would not have been visible, but in fact, the raking geison block above would have partly obscured any view of the surface except at the very front edge, which has a smoother finish, faintly preserved, than the surface above and behind. The resting surface for the raking geison above is smoothly finished with a small flat chisel. The setting line is between five and six centimeters away from the edge of the sloping surface, indicating that for the contact surfaces of both blocks there was a degree of tolerance. The front slope of the preserved corner block presents a problem for the lip of the raking geison, as the lip would have to accommodate the slope until it is free of the surface. **Fig. 86** and **Fig. 87** This problem was not illustrated in Broneer's reconstruction. **Fig. 85 middle**

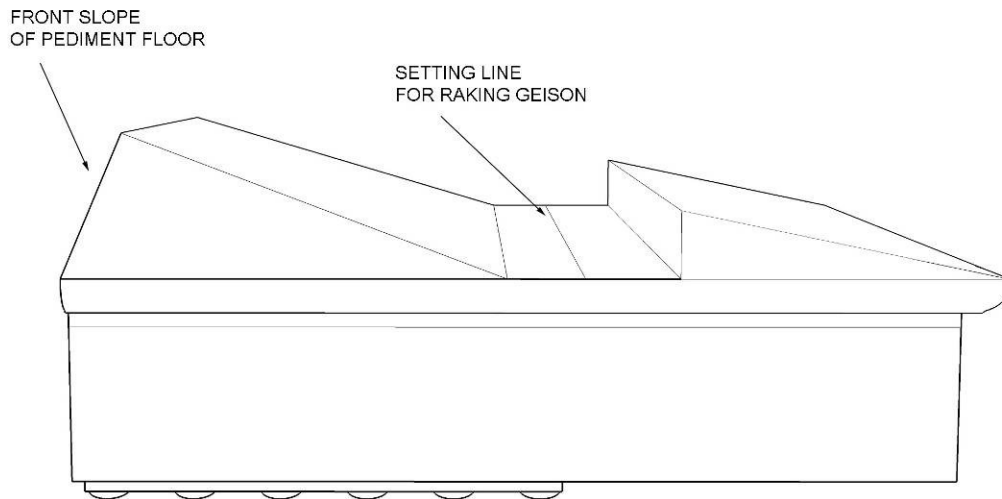

Fig. 86. Restored perspective view showing setting line and resting surface for the raking geison and front pediment slope.

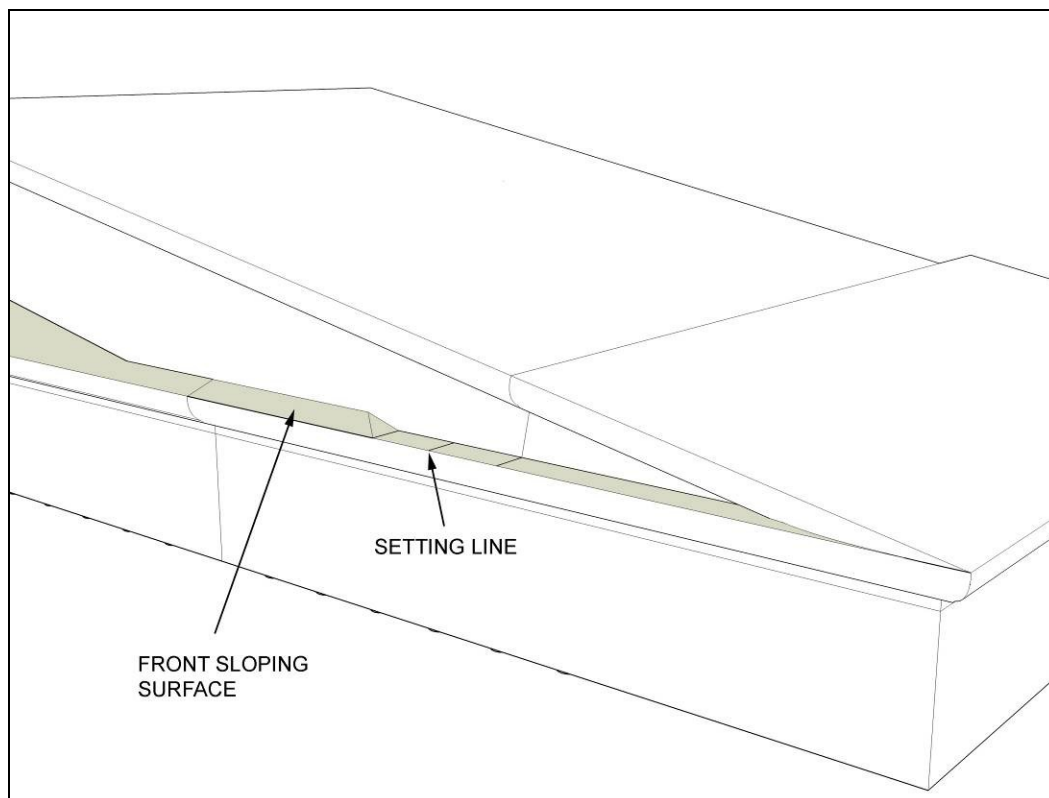

Fig. 87. Corner geison reconstructed, with beginning of raking geison, showing problem of the sloping front surface for the front lip of the raking geison.

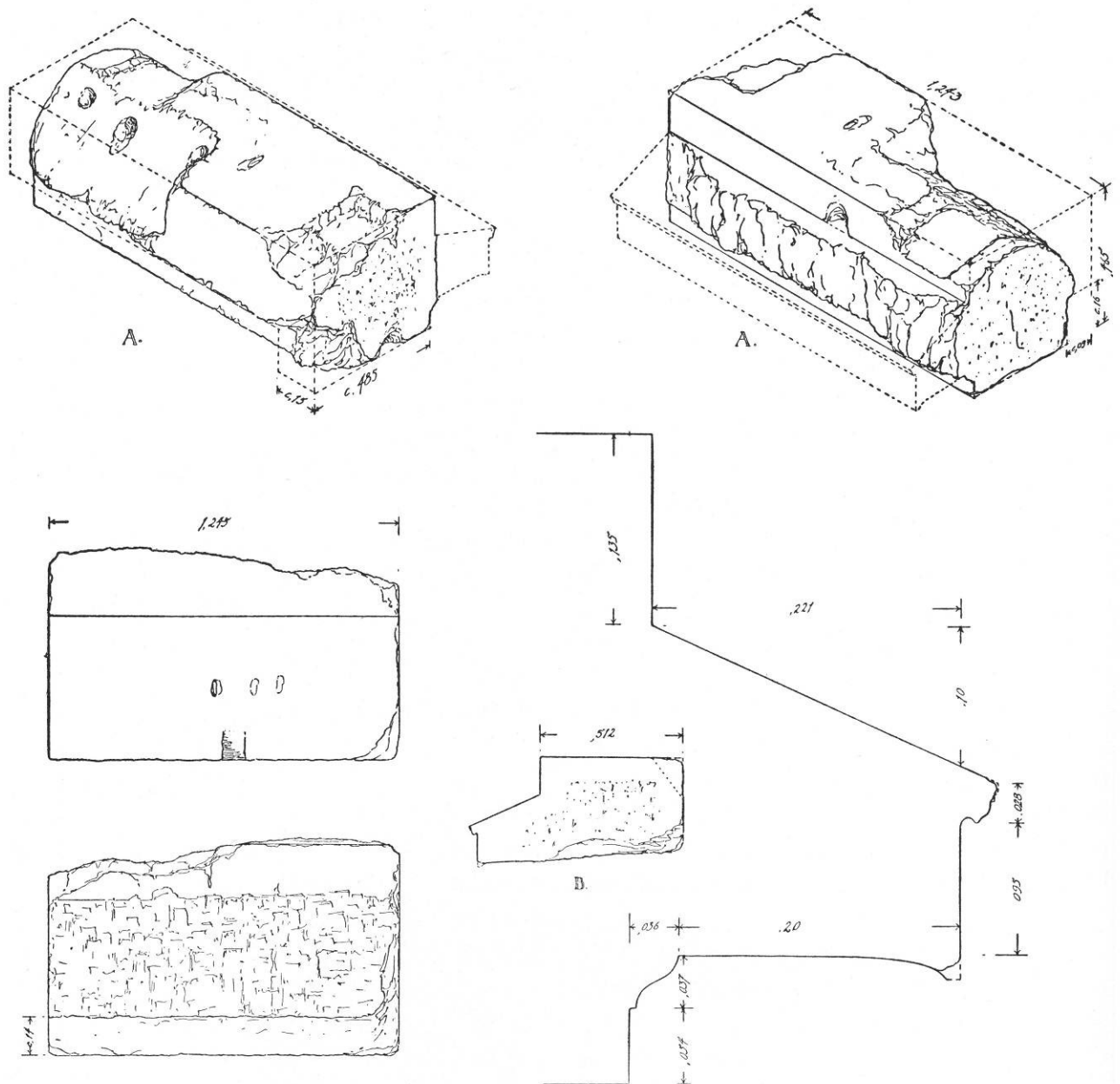

Fig. 88. Cornice without mutules (Broneer 1954, Fig. 33).

Cornice Without Mutules

A second type of cornice is preserved, which has a horizontal upper surface and no mutules. **Fig. 88** The cornice has a Doric hawkbeak crowned

by a cavetto and a cyma reversa molding at its base.²²⁰ The total projection of the front face of the cornice, not counting the cavetto and hawksbeak, is 0.221 m., with about 0.24 m. of space for the soffit. The upper face projects slightly farther than the lower face. The total width of the top surface is ca. 0.512 m. and the width of the bottom is ca. 0.485 m. The total height is ca. 0.527 m., which is consistent with the range of wall block heights in the building. At the back lower edge there is a rebate, 0.09 m. deep and 0.16 m. high.

If this cornice goes on the South Stoa, one possible position for it is on the back of the building, at the junction between the lower and upper floors and above the exterior doorways. The rebate was perhaps intended as a lip under which the upper floor boards were set. Whether the cornice would continue across the entire back of the building, or would be restricted to areas above the doors is not known. **Fig. 89** The position in the wall coursing would come just at the level of the flooring for the upper storey and provide a break in the wall between the two storeys when viewed from behind the stoa.²²¹ The cornice would shed the rain from the doorways at the back.

²²⁰ Broneer (1954, 54, 55, Figs. 32 and 33) found a number of these cornice blocks, mostly mutilated and none retaining their full original molding. He restored this cornice as a string course for the inner façade. The use of such a projecting cornice on the interior of the building is out of character with its function, however, and I know of no parallels for such a position.

²²¹ Coulton (1968, 160-161) following Versace (1908, Pl. xiv. 4) shows a similar cornice for the back and sides of the Amphiarion Stoa at Oropos. Coulton notes other buildings which have a similar cornice: Stoa J at Samothrace (Conze and Hauser 1880, 50, Pl. LVI.iii), the L-shaped Stoa on the Agora at Delos (Vallois 1944, 213-215), and the Megarian Treasury at Olympia (Curtius, Adler and Treu 1880, pl xxxiv).

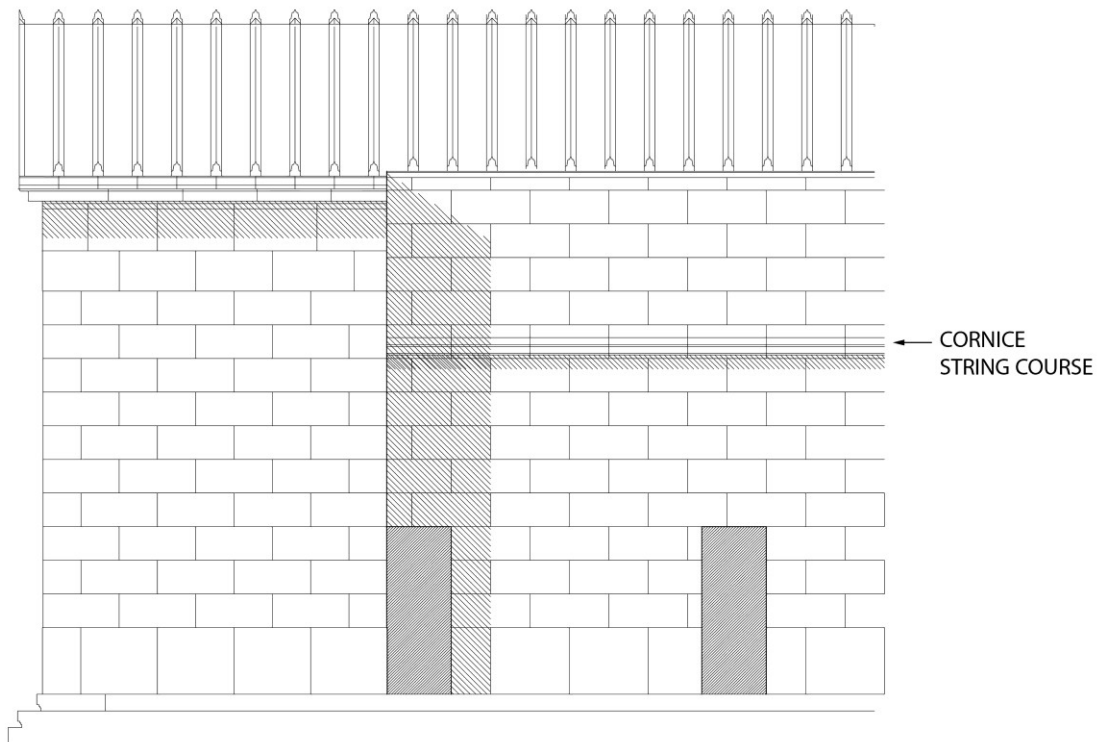

Fig. 89. Back of stoa showing possible position of cornice string course.

Another possible place for this cornice is above the interior colonnade of the balcony level, in which case a tie beam would fit in the slot at the back of the cornice and run back to the front wall of the back rooms. **Fig. 90** The dimensions of the cornice work for its restoration in this position. The cornice would rest, presumably, on a wooden architrave, since the span would be rather long for stone. In this position the cornice would rest on the same level as the Doric cornice at the front of the building.

There are at least two drawbacks to putting the cornice in this position. The hypothetical tie beams running from the front colonnade to the interior colonnade would be impossible with the cornice at this level. Also, Coulton

has pointed out that interior colonnades in stoas do not carry stone entablatures, so in any case it would be unprecedented in this position.²²²

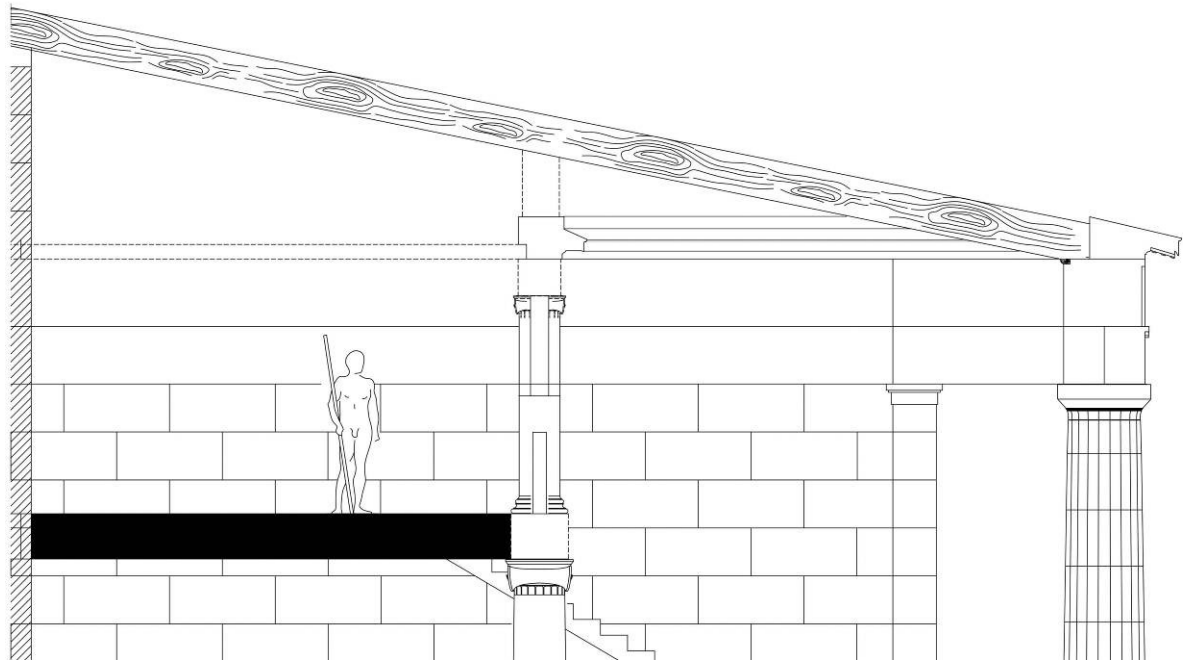

Fig. 90. Hypothetical reconstruction of geison above interior colonnade.

The third possible position for this cornice would be along the horizontal geison of the pediment beyond the anta, but the projection of the geison is less than that of the normal Doric geison, making it possible only if there were an awkward transition. **Fig. 91** In this position the cornice would respond to the Doric geison of the front. The step above the sloping cornice would be the bed for the tympanum and the slope of the cornice continues that of the Doric corner block. This arrangement would be a possible solution in buildings where there is an abrupt transition from Doric frieze to wall on the exterior and where the geison must continue in some form. Normally, in

²²² Coulton 1976, 120. Although, it could still be argued that lack of comparanda does not preclude the possibility of a stone entablature.

prostyle temples, the Doric frieze and geison continues along the flanks regardless. In the Propylaia on the Athenian acropolis, there is a special case where the Doric entablature stops and a different cornice continues along the side of the building. **Fig. 92**

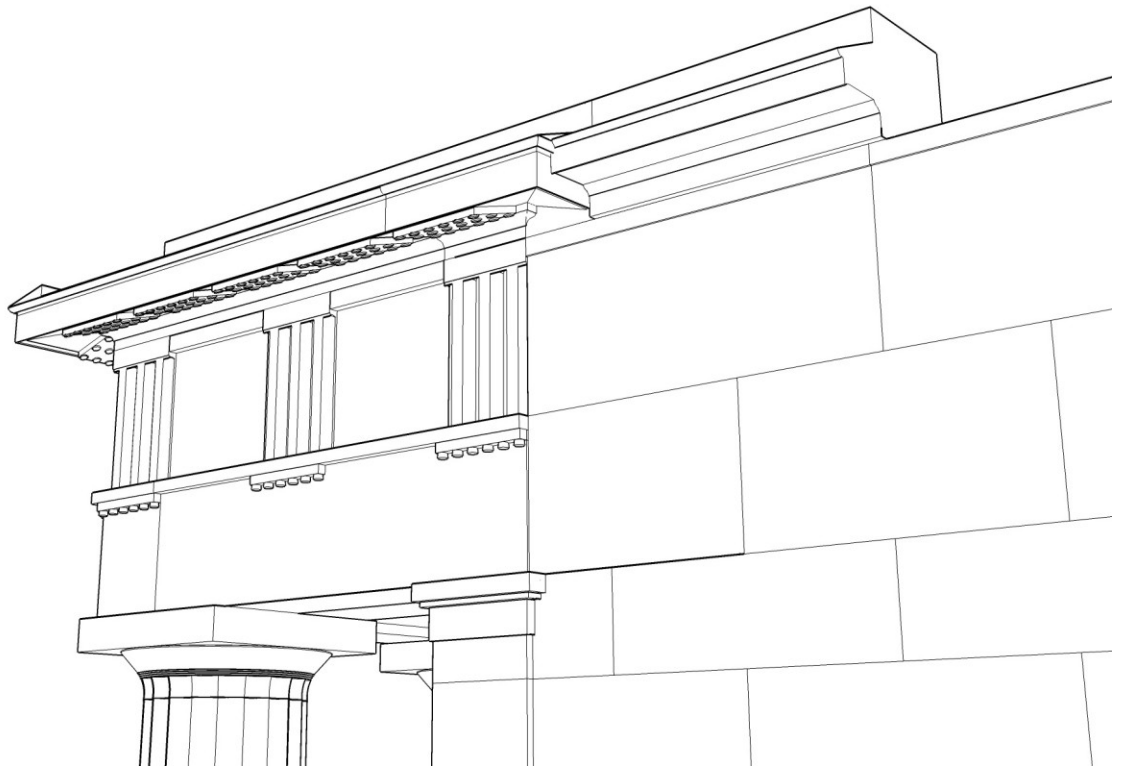

Fig. 91. Hypothetical reconstruction of geison without mutules used for the continuation of the horizontal geison on the side walls.

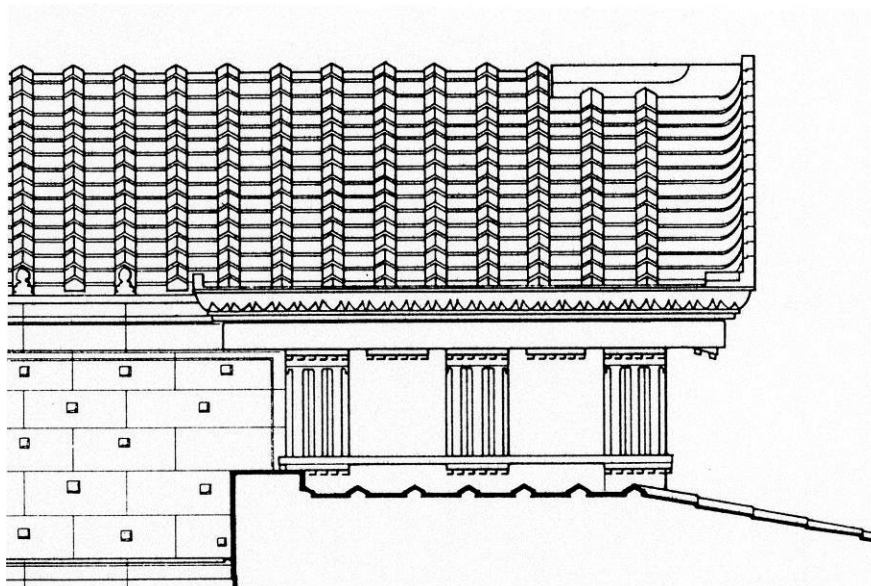

Fig. 92. Propylaea at Athens. Condition at N.E. corner of central building where Doric frieze and cornice stops on side wall (Tanoulas 1997, Fig. 4).

Chapter 8

Pediments

That the South Stoa had pediments on both ends of the building and not a hipped roof is certain based on the evidence of the corner geison block which preserves the start of the attached raking geison discussed above (**Fig. 85**).²²³ The resting surface for the next raking block has a slope of ca. 16 degrees (=28.67 percent grade). The raking geison which rested on top of this slope should have had contact all the way to the bottom of the slope. At the bottom edge of the slope is a setting line 0.05-0.06 m. out from the edge. **Fig. 86**. I have no explanation for why this may have been done, other than to provide a margin of space for slight discrepancies between the actual slope of the raking geison and the slope of the surface on which it rested. The slope angle of the raking geison has been calculated as ca. 14 to 16 degrees. **Fig. 93** With the slope of the roof estimated, it is possible to restore the tympanum of the pediment with possible block alignments as shown. **Fig. 94**

²²³ Broneer also restored the building with pediments on the ends (see Broneer 1954, Figs. 15, Plans XI, XIII, XIV) and discusses this important block (*ibid.*, p. 42).

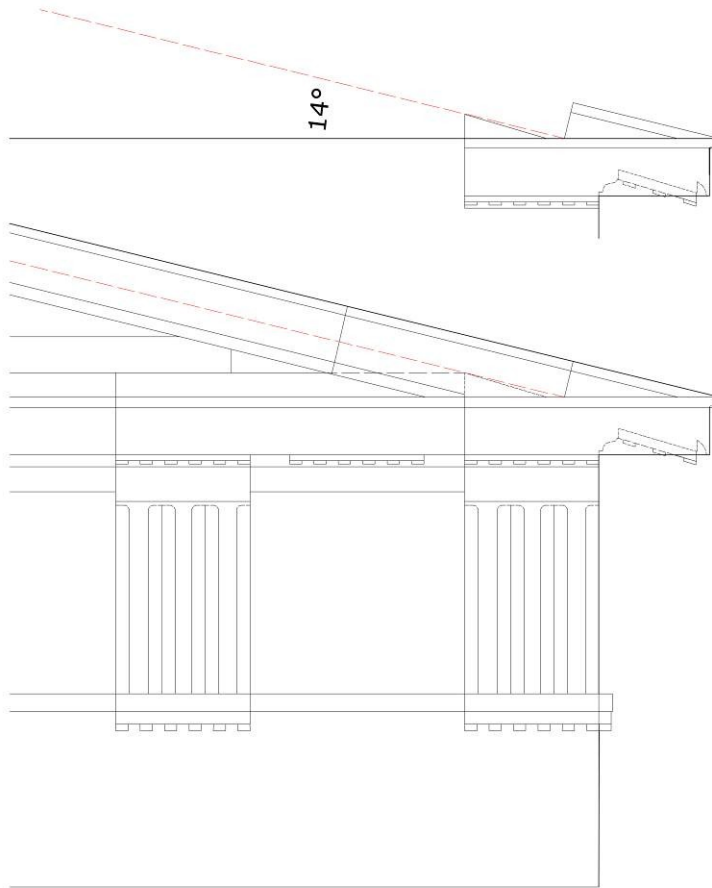

Fig. 93. Reconstructed corner geison showing slope of raking geison indicated in red according to new measurements.

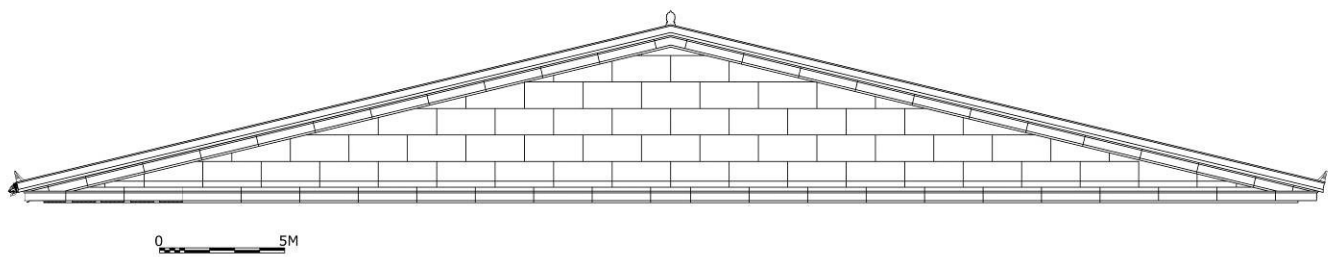

Fig. 94. Reconstruction of pediment showing possible scheme for blocks.

Chapter 9

Backrooms

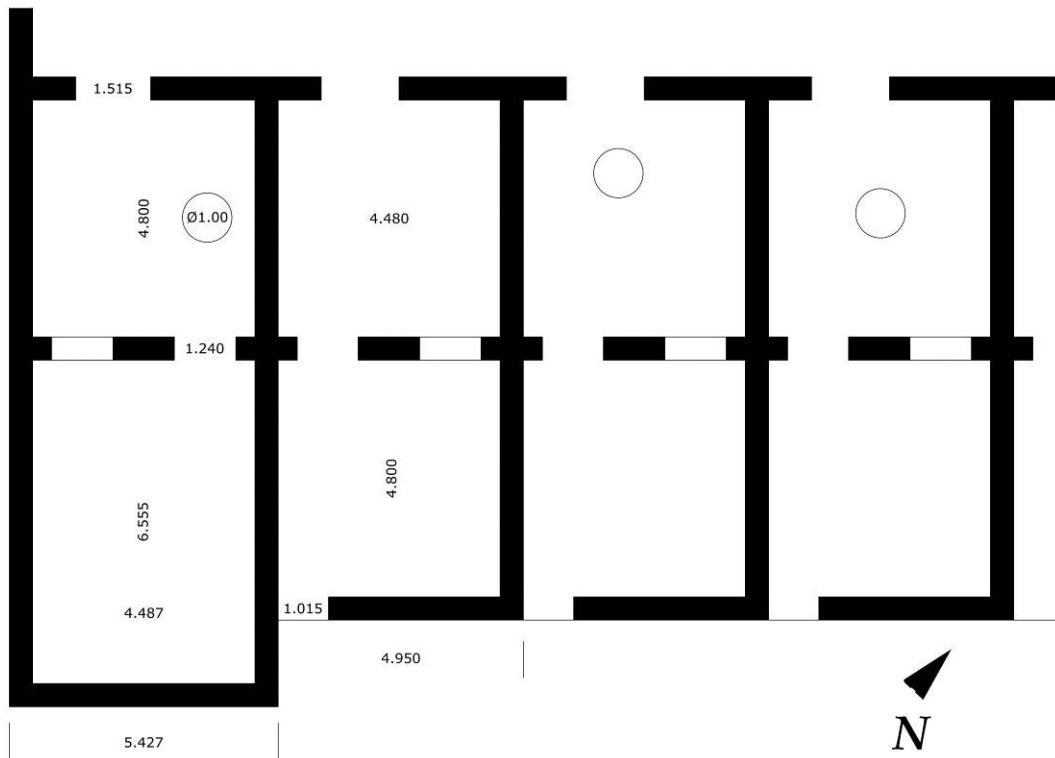

Fig. 95. Back rooms of stoa at west end. At both ends of the building the last room extends to the full depth of the building, while the rest of the rooms stop before this depth. Note the wells, which are not centered in the rooms with any degree of consistency.

The Front Wall of the Backrooms

No part of the front wall of the backrooms is preserved beyond a few courses of its original height. The wall must have risen to the height of ridge of the roof, which it supported. The total height of the wall can be calculated approximately based on evidence of the height of the wall blocks and the height of the monumental entrance to the South Basilica in the Roman period, which occupied the line of the wall and must have risen to its top. The height

of the Roman entrance has been established as ca. 10 meters.²²⁴ If 17 wall blocks 0.53 m. in height were used, their height equals 9.01 m., plus an orthostate height of 1.05 m., which makes the total height of the wall 10.06 m. If the height of the wall blocks is 0.54 m., 17 blocks equals 9.18 m. in height and the total height with an orthostate would be 10.23 m.

Doorways

The doorways that led from the colonnade into the backrooms were set off center toward the west, with the exception of the first room at the east end, where the doorway is offset toward the east, probably as a means to balance the two rooms at either end of the building. **Fig. 95 and Plan 1** Fragments of the orthostates and wall blocks with door trim exist, which provide enough information to reconstruct the doorways. **Fig. 96, Fig. 97, Fig. 98 and Fig. 99**

²²⁴ See below on the monumental Roman entrance.

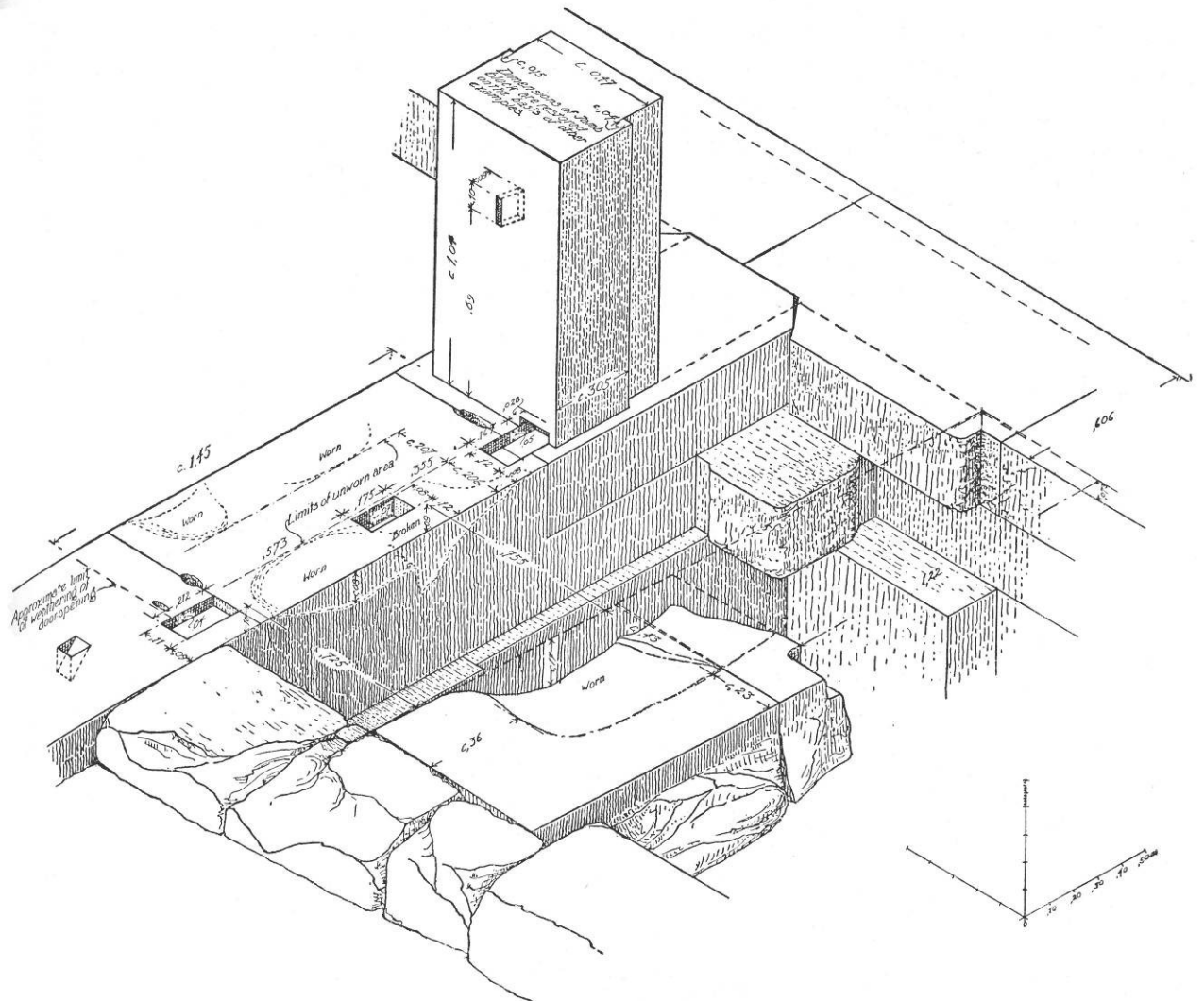

Fig. 96. First doorway at east end showing east jamb in situ and cuttings for the doors (Broneer 1954, Fig. 26. See Broneer *ibid.* p. 48, 49, for discussion of its finding).

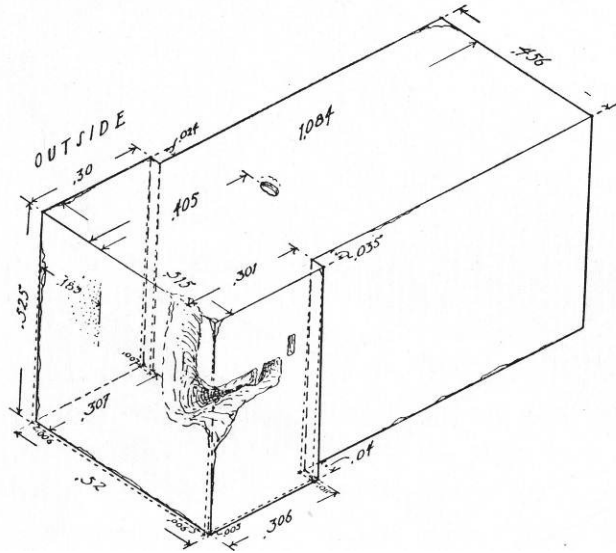

Fig. 97. Doorway wall block from second course, east side (Broneer 1954, Fig. 27). This block was found in the Cryptoporticus of the South Basilica (see Broneer *ibid.* p. 50 for its finding).

52

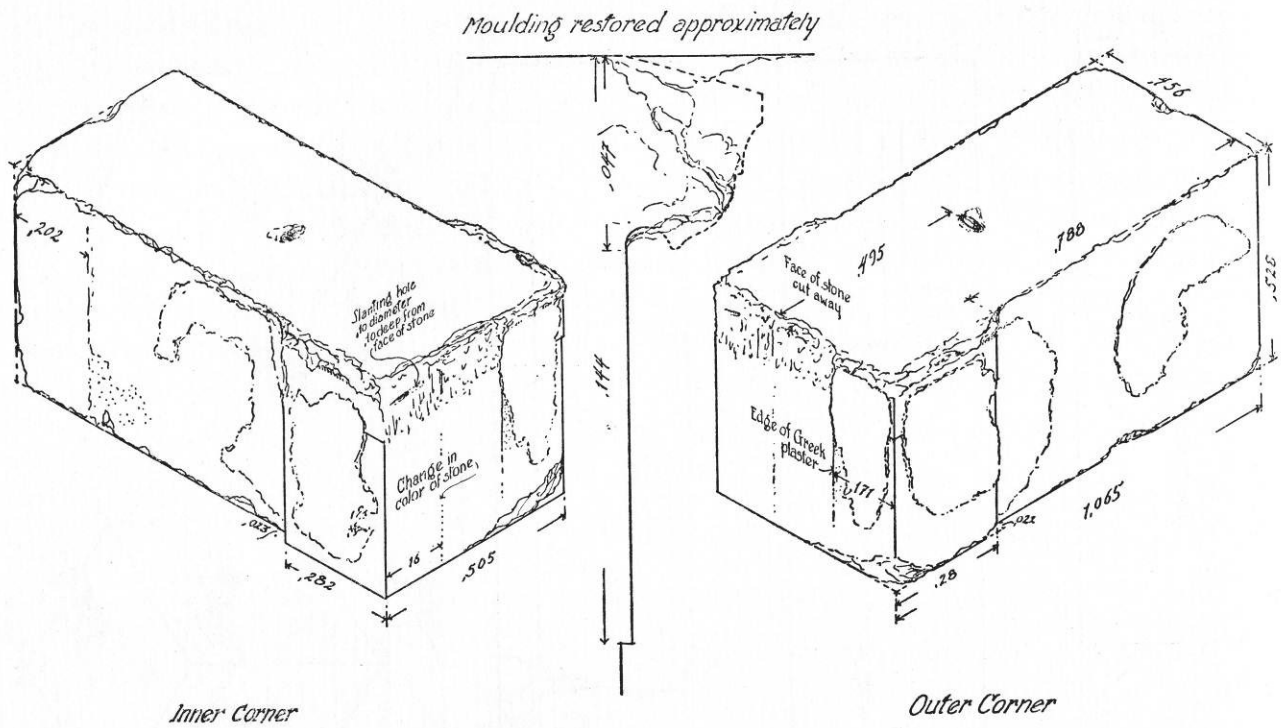

Fig. 98. Doorway wall block from top of wall with hawksbeak moulding partially preserved (Broneer 1954, Fig. 29).

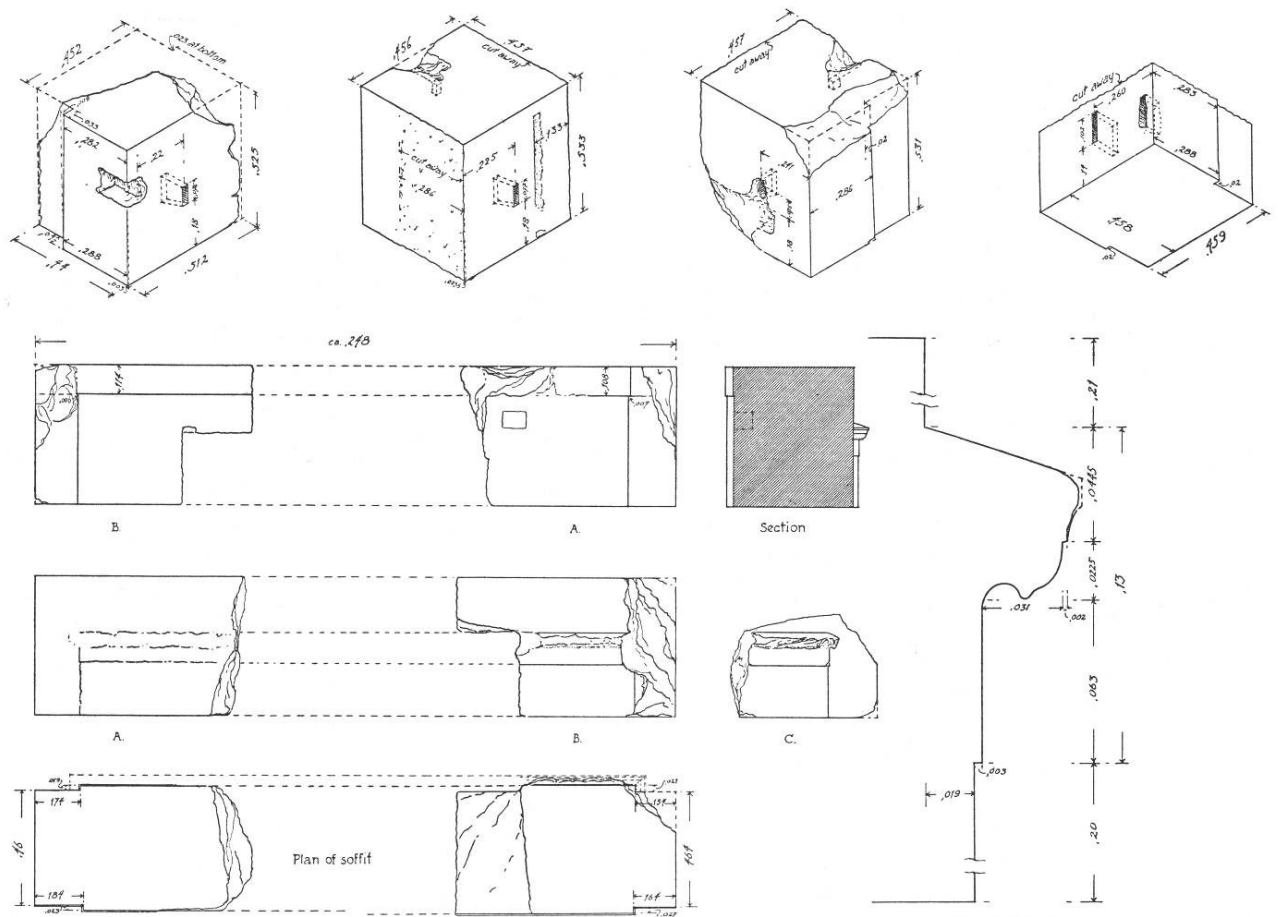

Fig. 99. Two lintel block fragments and four short blocks belonging to the doorways (Broneer 1954, Fig. 28). The short blocks have dowel cuttings to hold the wooden door frame. The lintel is surmounted by a hawksbeak, restored in the drawing.

Each doorway would have had a projecting trim on the inside and outside rising from the orthostate course up through the wall blocks to the bottom of the lintel. The trim measures ca. 0.30 m. in width at the base, gradually tapering to 0.28 m. at the top and projects ca. 0.05 m. on the inside and ca. 0.13 m. on the outside. Both sides of the doorway also taper from bottom to top so that at the level of the threshold the doorway is approximately 0.14-0.16 m. wider than at the top below the lintel.

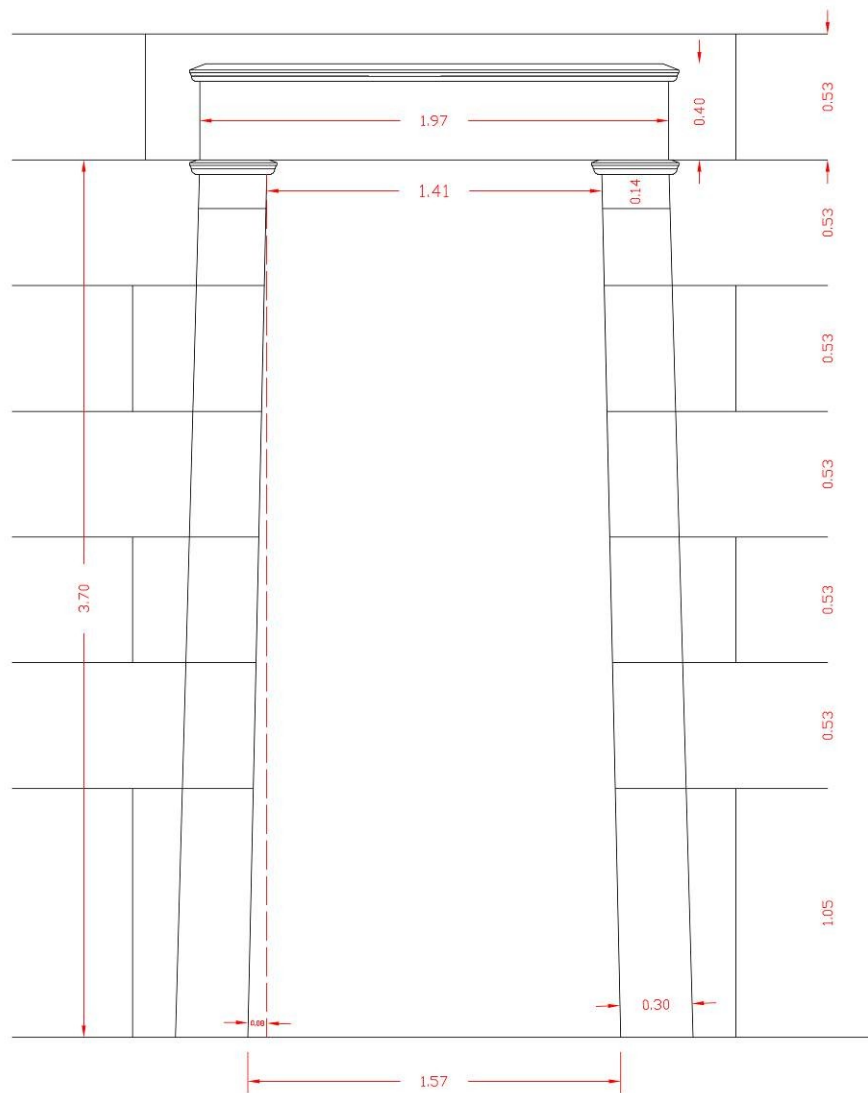

Fig. 100. Doorway in front wall of back rooms reconstructed with principal dimensions.

Restoring the total height of the doorway and its overall proportions depends on the number of wall block courses and the height of the individual blocks.²²⁵ **Fig. 100** The number of courses used must be weighed against the

²²⁵ Broneer used three wall courses above the orthostates ($3 \times 0.53 + 1.05 = 2.64$ m.) to the bottom of the lintel. This would produce a height of 2.64 m., which seems too short given the overall proportions of the exterior colonnade. In the Stoa of Attalos

overall height of the exterior and interior columns and the overall height of the walls and the roofline, which must be divided in such a way that there is sufficient clearance left for the upper floor. If five wall block courses measuring 0.53 m. in height are used, the total height from threshold to the bottom of the lintel course would be 3.699 m. and from the threshold to the top of the lintel is 4.228 m. This height works well with the ceiling height determined by the staircase. A plain taenia along the back of the lintel at its top edge suggests that the ceiling probably rested on top of the lintel course.

Fig. 101

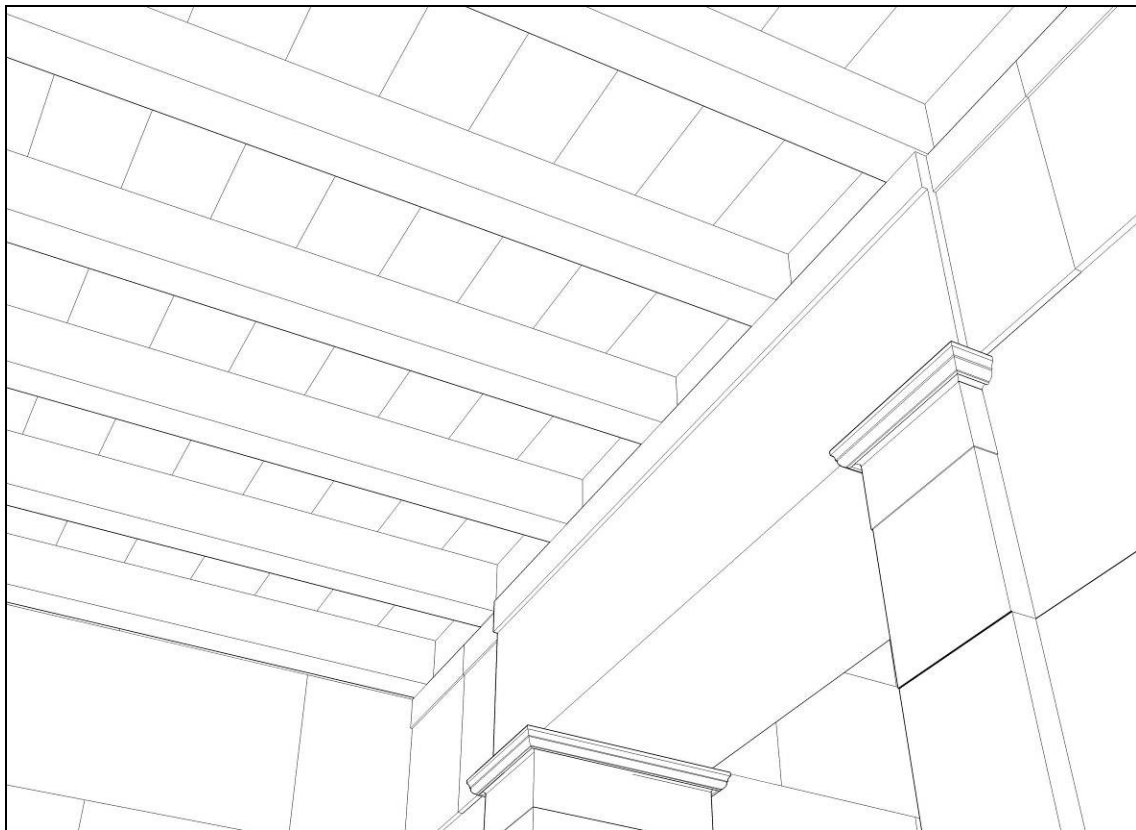

Fig. 101. Perspective showing back of lintel from inside room with hypothetical position of beams for ceiling.

the doorways are 3.43 m. from threshold to the bottom of the lintel and the exterior columns are over a meter shorter than the South Stoa columns (5.236 m.).

Lower Floor Level

The backrooms of the lower storey are divided from the front half of the building by a wall with doorways leading into each room from the colonnade on the north side. As was already discussed concerning the foundations, the back half of the building was designed using a different module than the one used for the front half of the building. The overall length of the building was divided so as to create thirty-three rooms. These units were subdivided into front and rear rooms. At the two ends of the building, the rear rooms project to the full extension of the overall width of the stoa, making these two rear rooms greater in depth than the other rooms. The rest of the rear rooms are the same depth as the front rooms, leaving an open space behind all of the rooms except the two ends. The reason for the deeper rooms at the ends must have been to make the roofline even on both sides of the ridge at the two ends of the building. The exterior space behind the rest of the rooms only makes sense if the intention was to leave room for additional construction at the back of the stoa, with the result that latrines were installed in this space, but apparently not in the first use of the building.²²⁶

The “normal” room dimensions are 4.48 m. in width and 4.80 m. in depth, measured to the faces of the walls. The same dimensions center to center on the walls are 4.96 m. in width and 5.27 m. depth. These dimensions apply to all the rooms except the end rooms. The two rear rooms at both ends have an interior depth of 6.55 m. and the depth center to center on the walls is 7.02 m. The width of the room units at the ends is also different from the

²²⁶ See below.

normal width. At the west end the interior width is 4.487 m., a difference of less than a centimeter, but at the east end the interior width is 4.587 m., a difference of just over ten centimeters.

Upper Floor Level

No evidence exists to reconstruct the upper floor of the South Stoa with certainty, but inferences can be made as to how it might be restored. It would be possible to calculate the height of the floor and thus the space taken up between the rafters and the floor surface based on the cuttings for the floor in the wall blocks above the doorways if it was possible to know the exact position in the wall coursing for such blocks, but this is not the case.²²⁷ Therefore, it is necessary to rely on the restored height of the staircase in the colonnade, which should rise to the level of the second storey floor level in the rooms.

Vitruvius (7.1.1-7) provides a detailed discussion of flooring, including upper storey floor requirements, albeit from the 1st century B.C. It is possible, therefore, to make a minimum estimation of what materials would be required and the overall thickness of the layers based on these requirements.²²⁸

Fig. 102

²²⁷ See Broneer 1954, 44-45, for placement of these blocks according to his reconstruction. There is no way to know which course these blocks go, and I have discounted the probability of the cornice on the interior above the doorway.

²²⁸ See Coulton 1976, 147. Vitruvius is describing floors (*Contignatio*) for mezzanines in many different types of buildings, but primarily buildings where the wood beams would be supporting masonry above. Archaeological evidence exists in the mezzanines of tabernae at Pompeii, Herculaneum and Ostia, which shows that less heavy structural beam support than Vitruvius specifies could be employed. See R. Ulrich (1996, 137-151) for a useful discussion of the evidence for *Contignatio* and how it relates Vitruvius.

Vitruvius' requirements

1. Wood planks nailed to joists (*contignatio, coaxatio*)
2. Layer of straw or fern under a thick layer of rubble and crushed stone mortar, pounded down (*statumen*)
3. Layer of crushed brick mortar (*rudus*)
4. Finishing surface of brick, mosaic or marble slabs

The total thickness of the floor including planks and joists would be at least ca. 0.40–0.50 m.

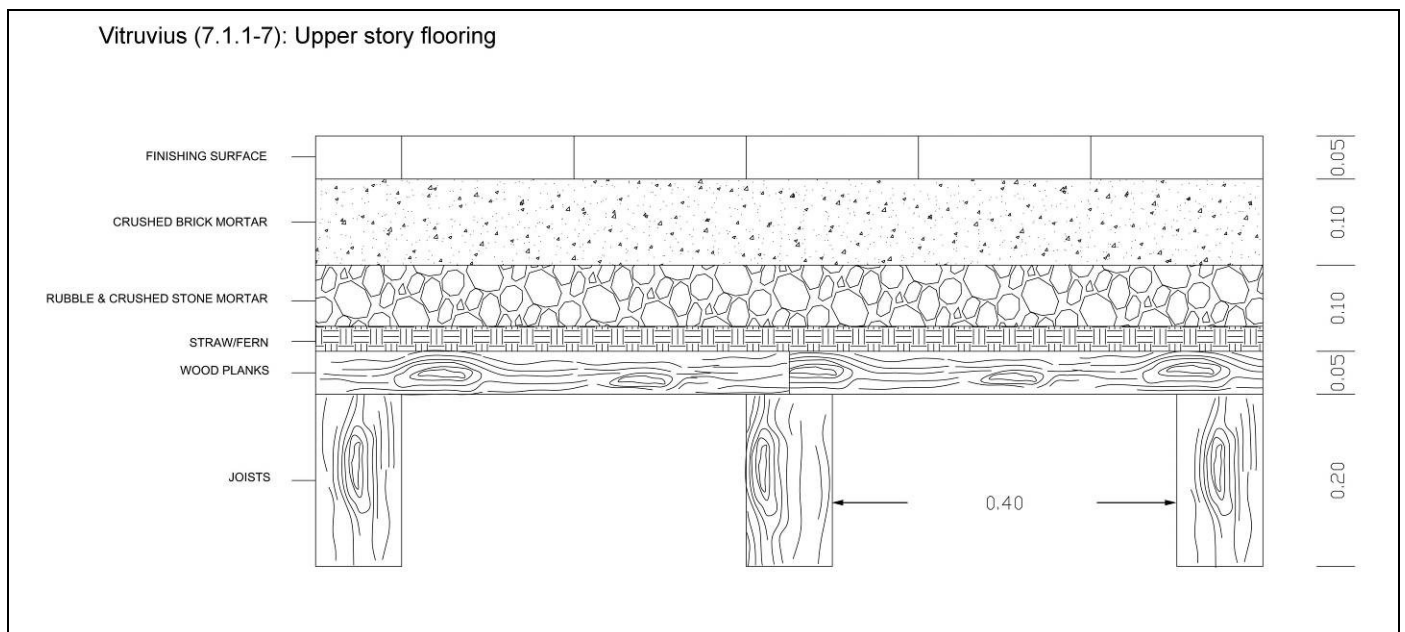

Fig. 102. Necessary components of upper floor following Vitruvius.

This would be a conservative estimate for the makeup of the flooring in the Roman period. Obviously, prior to the Roman period, the flooring could have been much simpler and might have consisted of just wood planking on top of joists. One might expect that in a building as sumptuous as the South Stoa, something more would be utilized, however. The best comparanda prior

to the Roman period comes from the North stoa on the agora at Assos. **Fig. 103** Koldewey restores an upper floor with a thickness of ca. 0.50 m., based on the fact that the cornice and upper stylobate for the parapet are roughly finished on the inside face, meaning that the floor would have covered the backs completely. This would be roughly the thickness for the kind of floor that Vitruvius recommends and Koldewey restores.²²⁹ For most if not all two storey stoas, the flooring would occupy the space relegated by the height of the cornice and upper stylobate, if this element was present. In some cases, it might just be the height of the cornice. This height, then, could fluctuate anywhere from ca. 30 cm to ca. 50 cm. depending on the size of the building and whether or not an upper stylobate was included.²³⁰

²²⁹ Clarke, et al. 1902-1921, 45; See Coulton 1976, 147ff., in which he points out that there is no sure evidence of the practice that Vitruvius recommends, except that the North stoa at Assos demonstrates that there is room for such flooring.

²³⁰ See Coulton 1976, 147-148. The main evidence for flooring space comes from two storied stoas of the Hellenistic period, ie. the Stoa of Attalos at Athens, the other Pergamene stoas, and the stoas at Assos.

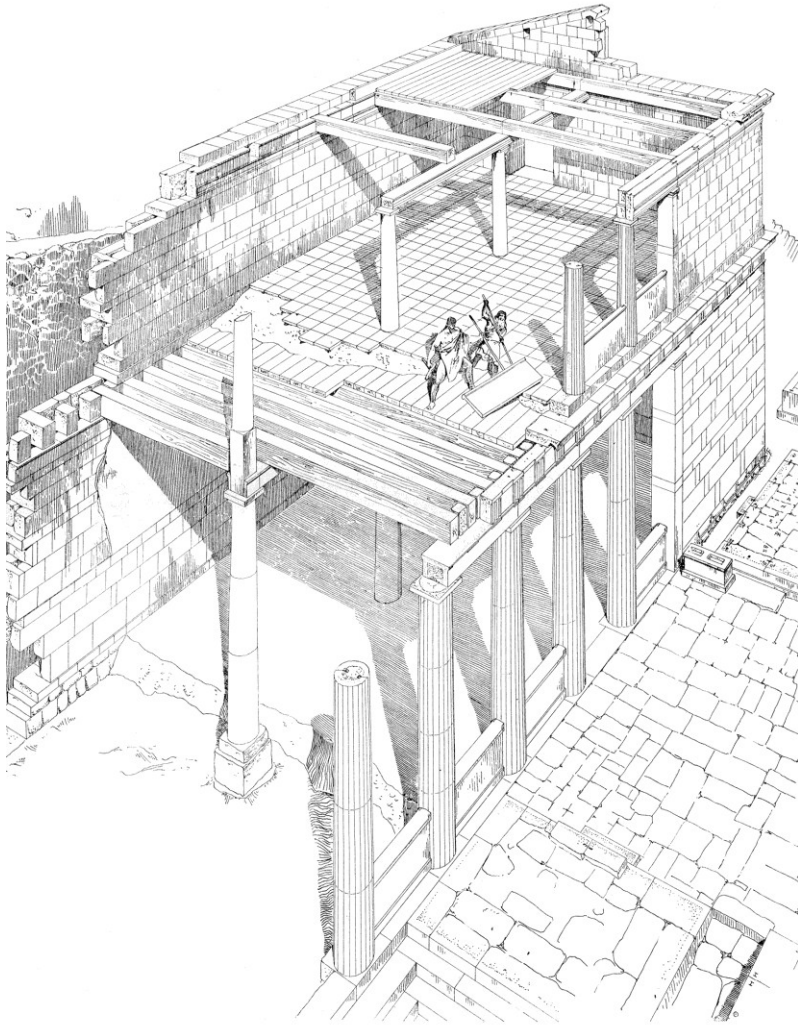

Fig. 103. Perspective reconstruction of the North stoa on the Agora at Assos. Note the thickness of the upper floor, which is evidenced by the rough finish of the backs of the cornice and upper stylobate on which the parapet rests. Note also the thickness of the ceiling beams, evidenced by the back wall construction (Clarke, et al. 1902-21, 45).

Upper Floor Layout

The layout of the upper floor rooms is not known beyond the few fragments of small elements which might be restored there. It is possible the walls of the upper floor follow the wall lines of the lower level, but whether or not there were passages between rooms or whether or not rooms were of different dimensions is conjectural and the weight of the evidence does not provide an answer to these questions. Previous attempts at reconstructing the

layout of the upper floor rooms have rested on the supposed function of the building and the practicalities of communication between rooms. As discussed above in the introduction, Broneer's restoration opened up the front rooms as a gangway to allow passage from one end of the stoa to the other. He also separated the rooms by columns and curtains. While he suggested the upper rooms were private, the space he actually restores would be more or less communal with little to no privacy. If, however, there was a balcony in front of the rooms, there is no need for a gangway inside the rooms and if the parapet fragments discussed below belong to a balcony in front of the rooms, then the windows in the front wall at the upper level can now be dispensed with.²³¹

Ultimately, the underlying question regarding the upper floor restoration is whether its use was public or private. If the rooms are meant to be private, then it might be assumed that they would have followed the lower floor plan in terms of size. Passage between rooms front to back would require doorways, like those on the lower level, which would seem awkward if the upper rooms were meant to be private. It is probably better to envisage rooms stretching front to back as private compartments, with several guests occupying a single suite.

²³¹ Broneer also restores small Doric columns between rooms in the upper storey. Although small Doric column fragments, including a capital, were found in debris from the wells and could theoretically belong in the upper storey, there is no way of knowing where they go and it is possible that they do not belong with the building at all (see Broneer 1954, p. 73, Figs. 46, 47, 48 and frontispiece). According to Coulton (1979, 102) the ratio of capital height to abacus width is unlike any of the capitals with which the capital should be grouped if it belongs to the stoa and is more in keeping with earlier proportions.

Chapter 10

Colonnade Staircase and Balcony

The foundations and cuttings for a staircase along the west wall of the stoa show incontrovertibly that a stairway existed here prior to the Roman period and in all likelihood was part of the original design of the building.²³²

Fig. 104 and Fig. 105

The first two steps of the staircase were set into the cuttings in the orthostate. The cuttings appear to be for the insertion of the bottom end of the lower run of a wooden staircase.²³³ They would have provided a secure footing for the run, while the upper end would have been nailed to the landing behind the anta. There would still need to be a platform of two more steps below the cuttings before reaching the ground level. The outside of the lower run rested on the stone foundations, which are cut to the angle of rise. Based on the spacing between the foundation blocks and the step cuttings, there is ample room for the stringer and a supporting beam below. This would provide more than enough strength for the stairs. The continuation of the staircase would have been made of wood. Foundations exist for a landing extending to the edge of, and out from, the wall anta so that another run of stairs would extend up toward the front wall of the backrooms of the second storey of the building. The lower beams of the staircase would be seated below ground level, but would be resting on and surrounded by stone, however, which

²³² See discussion above concerning previous scholarship.

²³³ This would have been a measure to keep the wood parts of the structure from contact with the ground to prevent rot, and would suggest that the floor on the ground level was of beaten earth.

would provide a degree of protection. It is possible too, that they were wrapped in lead at the base, further protecting them.

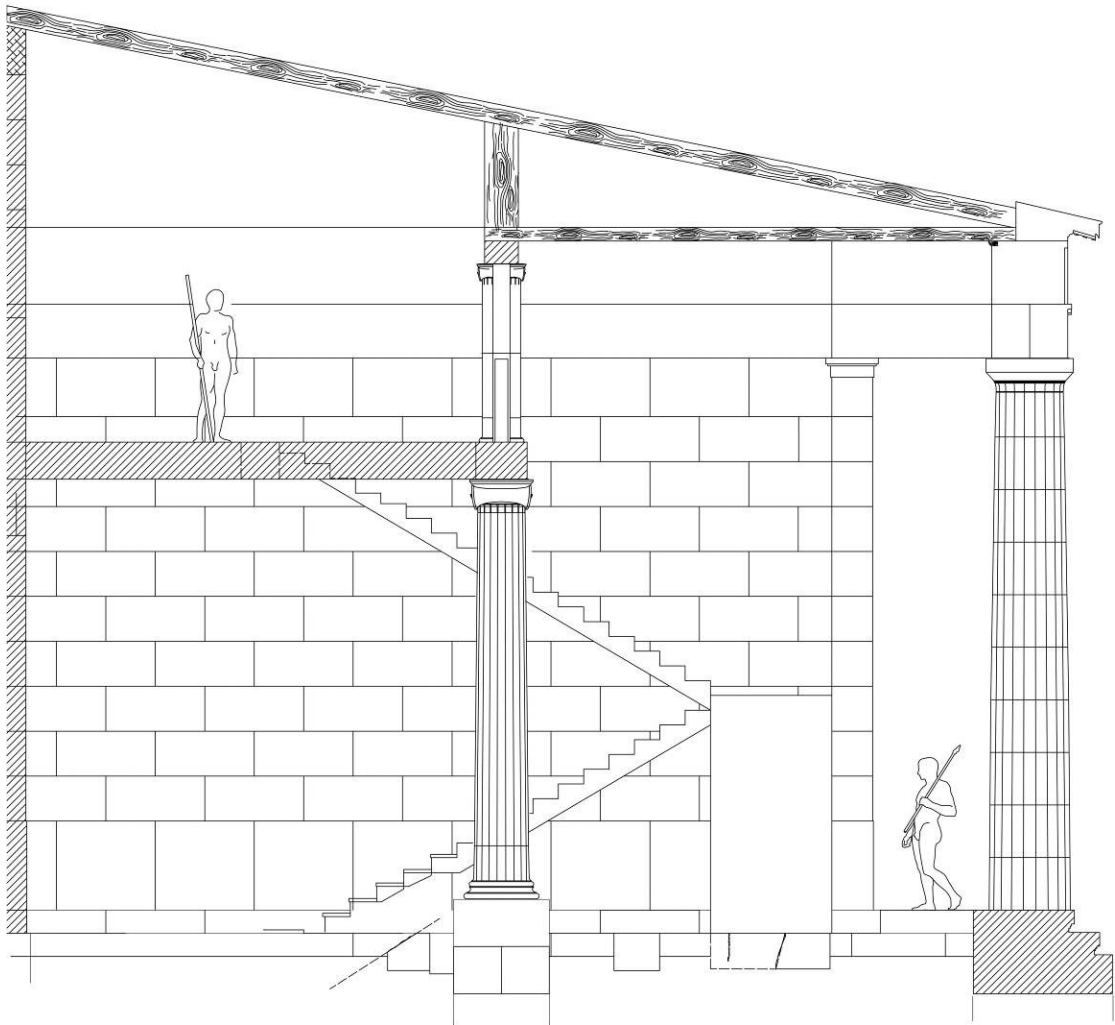

Fig. 104. Reconstruction of staircase against west wall.

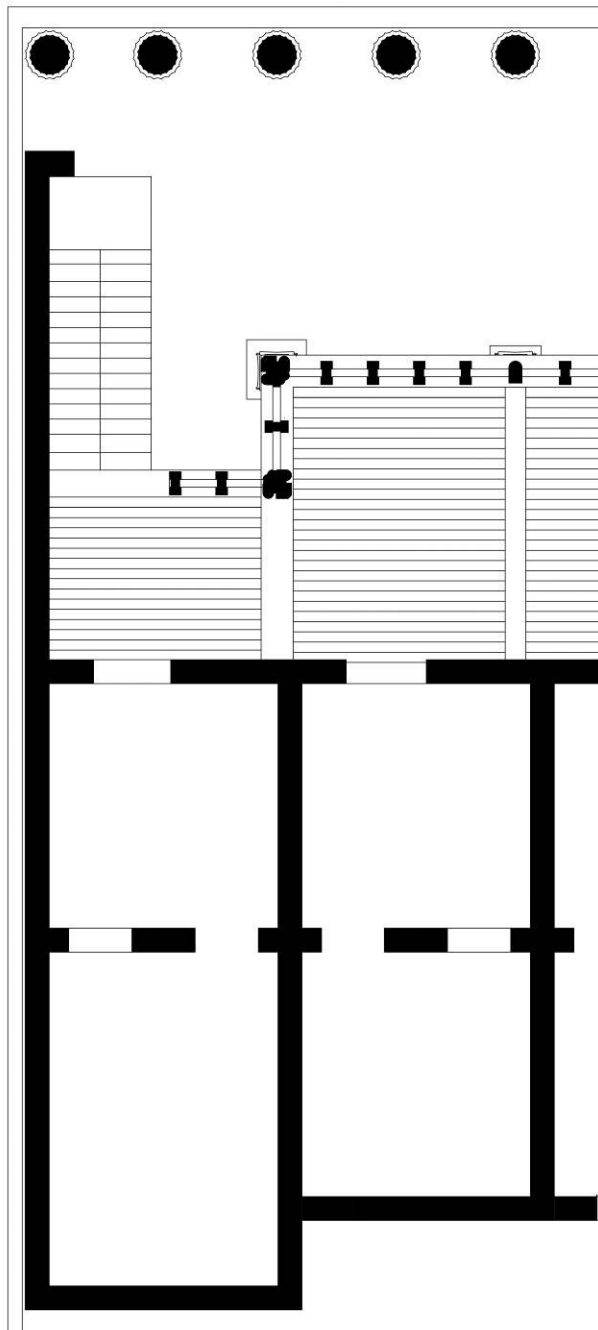

Fig. 105. Plan of upper floor level, showing hypothetical balcony layout.

The cuttings in the fifth orthostate indicate a riser height of ca. 0.17 m. and a tread between ca. 0.30 and 0.33 m. wide. The number of steps per flight can be restored as between thirteen and fourteen, which would leave

room for a landing behind the anta of approximately 1.30 to 1.40 m. in width.²³⁴

From the landing at the edge of the wall anta, the return set of stairs would extend up to the second floor, leaving space for a landing at the top in front of the backrooms, which is actually an extension of the balcony. If the return flight of stairs is only made to run up to, or slightly past, the line of the first step below, then the flight from the first landing to the second floor would be short enough to only require support at the top of the stairs, but the foundations suggest that a post was put in for the top run midway. **Fig. 106**

²³⁴ See Williams 1980, 127, 130.

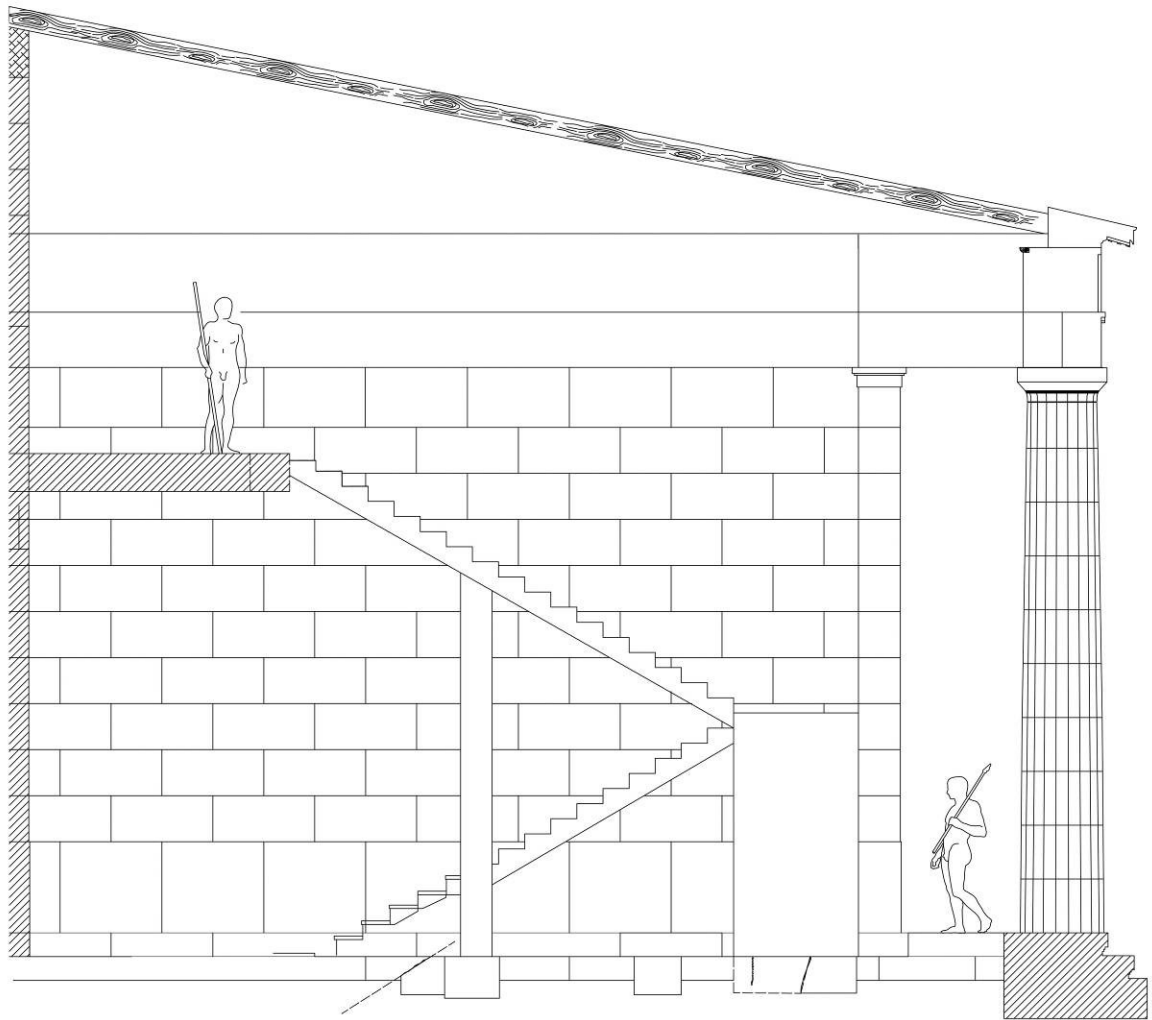

Fig. 106. Elevation of staircase against west wall.

The stairs would only rise as high as needed to reach the upper floor and this height is determined by the height of the doorway and lintel (ca. 4.23 m.) plus the additional height of the flooring above, which is ca. 0.50-0.60 m, making the total height for the flight of stairs ca. 4.90 m. This height, which could fluctuate depending on the height of the flooring by several centimeters, would leave ample space for a landing of ca. 3.88 m. in depth.²³⁵

²³⁵ It is unlikely that the staircase was a later addition to the stoa, since it would require extensive modifications affecting the interior colonnade and roof, and it would still not alter the calculations for a balcony in the upper storey.

The staircase and balcony provide the best explanation for the restored height of the Ionic columns of the interior colonnade. The interior colonnade in the original phase of the stoa consisted of Ionic columns with a base diameter of 0.66 m., seemingly too slender to reach a height necessary to support the roof or carry ceiling beams from the outer colonnade.²³⁶ The balcony would need to be supported in front of the wall leading to the backrooms and the Ionic columns of the interior could easily rise to the height necessary to support this balcony.

That such a staircase existed only at the west end of the building and not at the east end seems improbable given the length of the stoa. This fact alone suggests that a staircase was also constructed at the east end. Although no evidence has yet been found for one, there is no evidence which would negate the possibility of a staircase at the east end.²³⁷

²³⁶ See the restoration by Broneer (1954, 32-33, 46, and plans XIIIb, XIVb) for an attempt to reconcile the outer and inner colonnade heights. Even in his restoration, which shortens the outer Doric colonnade as much as possible, the Ionic columns are disproportionately slender. See also the discussion of earlier scholarship above.

²³⁷ At the east end of the building, the wall has been stripped away, leaving no trace of a staircase. Excavation, however, has not gone beneath toichobate level where foundations might provide evidence. A test trench made against the east foundations could confirm whether or not an identical set of foundations exists for a staircase at this end of the building.

Piers and parapet slabs

Several fragments of piers and parapet slabs are preserved, which could be assigned to the upper storey to form a parapet for the balcony above the interior Ionic colonnade.²³⁸ **Fig. 108**



Figure 107. Preserved sections of piers and parapet slabs.

²³⁸ Broneer 1954, 70-72, Figs. 42-44. The best preserved fragments come from well VII. Others were found within the building, but their exact locations are not recorded.

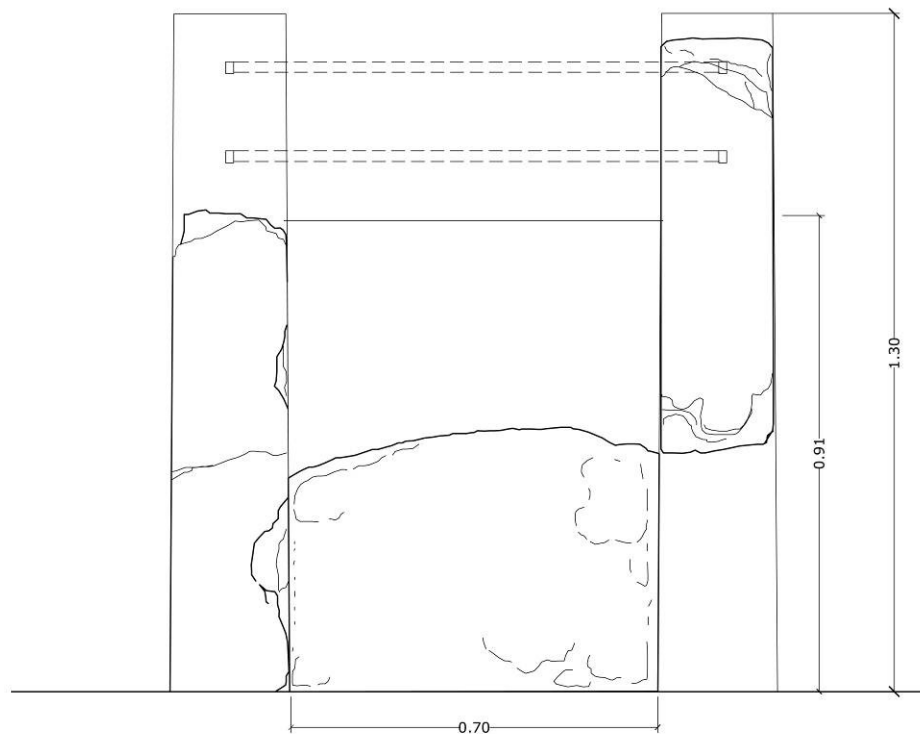

Fig. 108. Pier and parapet slab as restored.

The piers taper from the bottom to the top, measuring 0.23 x 0.46 m. at the base and 0.202 x 0.442 m. at the top. On either side of the piers are slots 0.15 m. in width and 0.028 m. deep, extending up the pier to a maximum preserved height of 0.93 m. The slots would not need to extend much higher than this for a parapet of logical height. **Fig. 108** There are also small pin holes preserved in a few fragments in what would be the front or back face, ca. 0.29 m. and 0.124 m. above the slots, possibly for the addition of horizontal bars in metal above the stone parapet slabs, which would serve to stabilize the piers. One fragment of a parapet slab was found which would fit

in the slots of the piers.²³⁹ The full width of the slab is preserved and is 0.73 m. The slab is only preserved to a height of 0.51 m., where it is broken off. The un-stuccoed edges of the slab are preserved and would indicate where it rested inside the pier slot to a depth of ca. 0.028 m. The piers themselves are not unlike the fence posts used for temenoi, such as the poros fence posts for the Eponymous Heroes monument in Athens.²⁴⁰ **Fig. 109** They become standard for parapets in stoa design, such as in the upper floor parapet and windows of the Stoa of Attalos at Athens.²⁴¹ At Corinth, they exist in a later incarnation of the North Stoa.²⁴²

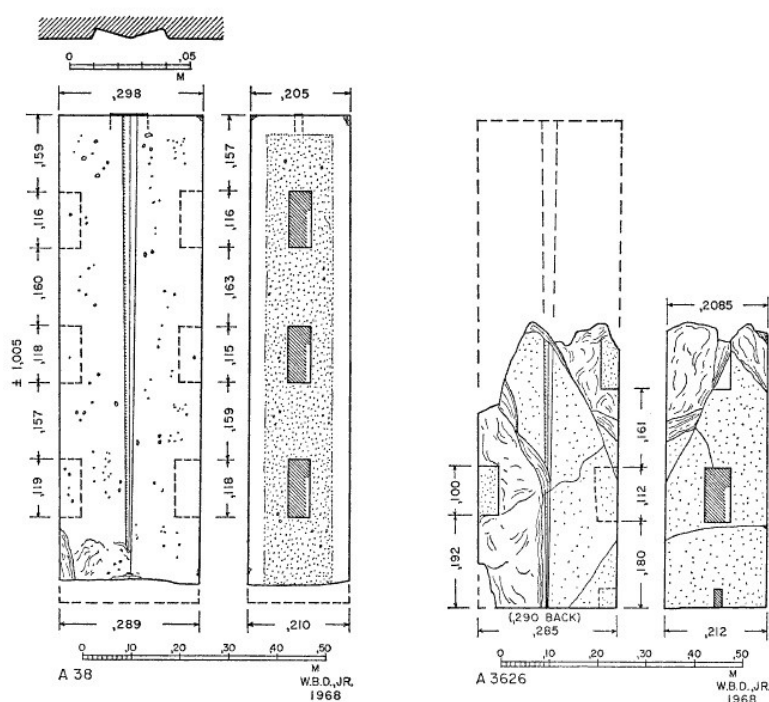

Fig. 109. Fence posts for the Eponymous Heroes monument in Athens (W. B. Dinsmoor 1968).

²³⁹ Broneer 1954, 72-73, Fig. 45. This fragment was found in well IX. Broneer restores these pieces as windows in the front wall of the back rooms (see Broneer *ibid.* frontispiece and Plan XIIIb).

²⁴⁰ See Shear (1970, 152) for the fence posts of the Eponymous Heroes, which differ in having three slots cut into the sides for insertion of wooden cross beams rather than stone slabs.

²⁴¹ Travlos 1971, 513, Fig. 645.

²⁴² Stillwell et al., 1941, Pl. X.

Pier Columns

There are fragments of pier columns of a size that could have been used in the upper storey. The columns are half fluted with flat sections on the sides to take a parapet.²⁴³ **Fig. 110 a. and b.**

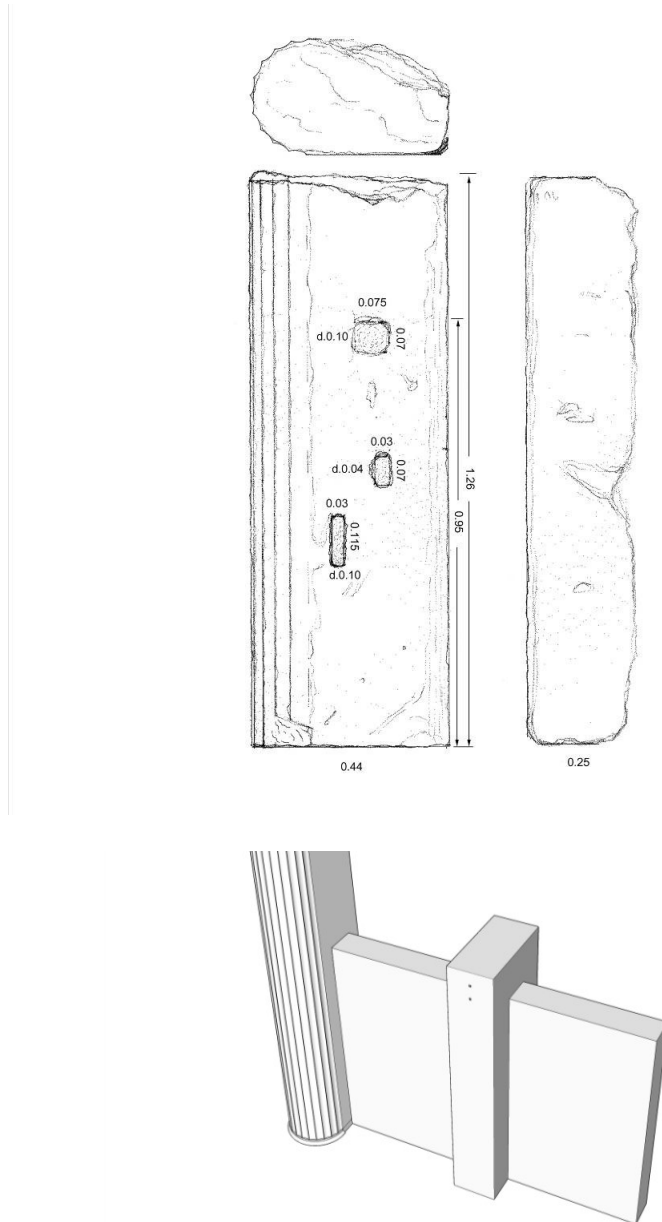

Fig. 110. a. Pier column as preserved; b. as restored with parapet slabs.

²⁴³ One of these columns is lying in the block field in front of the stoa at the west end. Another was found built into the circular base in front of the stoa at the east end and another was found behind the stoa at the east end. I thank C. K. Williams for pointing out to me two of the fragments on site.

The fragment shown in Fig. 110 has cuttings in the side for inserting dowels to secure a parapet. If the upper dowel hole secured a capping stone, it would provide the height of the parapet, which should be ca. 0.90-0.95 m. according to the evidence from the piers and parapet slabs discussed above.

No capitals or bases have been found for the pier columns although it is possible that a series of small pier capitals, thought to belong to the stoa, could be restored on top of the rectangular piers where appropriate.²⁴⁴ **Fig. 111** In the restoration, Ionic capitals and bases have been tentatively restored for the pier columns. **Fig. 112**

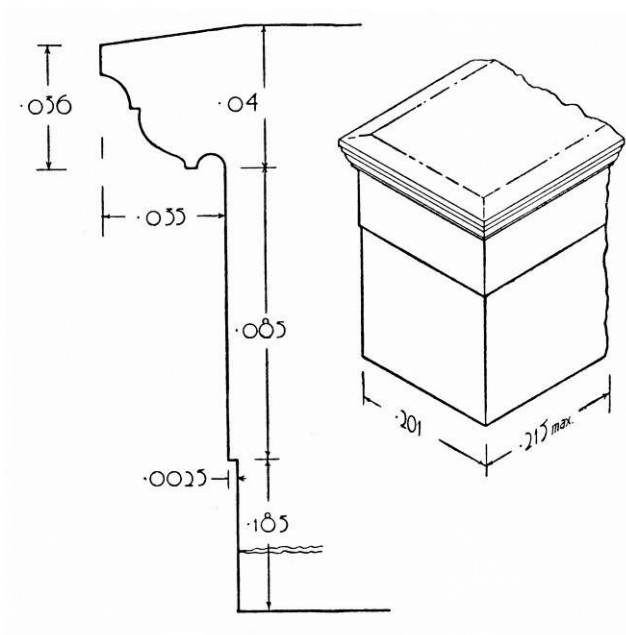

Fig. 111. Example of small pier capital (Broneer 1954, 78, Fig. 55.)

The most obvious place for these pier columns in the reconstruction would be above the interior ionic colonnade, in front of the backrooms, and in conjunction with the piers and parapet slabs. **Fig. 112**

²⁴⁴ See Broneer 1954, 77-79, Figs. 52-57.

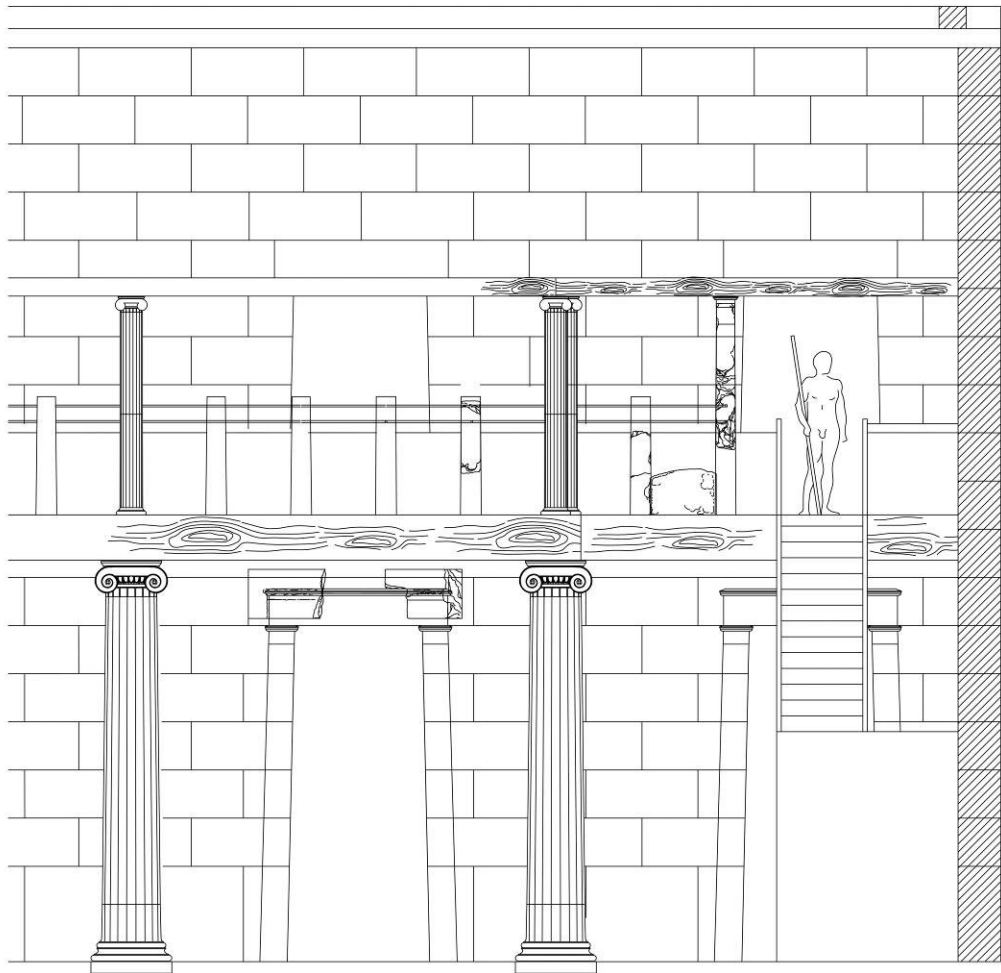

Fig. 112 Upper storey balcony showing possible position and reconstruction of parapet fragments with the reconstruction of pier columns.

The placement of the piers and parapet slabs above the interior Ionic colonnade is further supported by the rhythm of their spacing with the addition of the Ionic pier columns, which equals the rhythm of the lower interior colonnade (intercolumniation equals 4.68 m.). [(Slabs: 0.70 x 5) + (Col: 0.125 x 2) + (Piers: 0.23 x 4) = ca. 4.68 m.] Each pier column can be restored over a lower column with four piers and five slabs in-between. It is assumed that the pier columns, piers and parapet slabs rested on a wooden entablature above

the interior Ionic columns, since no stone entablature was found, but a stone entablature cannot be ruled out in this special case.²⁴⁵

The conditions for pier columns are substantially different than normal columns due to the increase in depth. Therefore, a narrower column diameter on a pier column is acceptable. The proportion of diameter to height for the pier column used in the reconstruction of the South Stoa is ca. 9.6. Normally the height of the interior order of the upper storey should have a ratio somewhere between 2:3 and 3:4 that of the lower order, if we follow Perachora and later examples with upper storeys such as the Stoa of Attalos. In the South Stoa the ratio is 2:3.7. Therefore the upper columns of the South Stoa are rather short in relation to the lower columns as compared to other examples.

If the balcony was designed as reconstructed here, it would mean that the South Stoa at Corinth exhibits an experimental stage in the design of stoas with upper levels. There are no obvious parallels for such a balcony in stoa design.²⁴⁶ In point of fact, for all we know, there may be more experimental designs than canonical ones in actual practice, but full documentation of many Greek stoas is lacking.

²⁴⁵ Nor are they attested for interior stoa colonnades anywhere else in the Greek world. Normally interior stoa colonnades carried a wooden entablature or just merely wooden beams (see Coulton 1976, 120).

²⁴⁶ South Stoa I in the Athenian Agora is restored with a split level interior. The stoa at the Sanctuary of Artemis at Brauron may have had an upper storey at the back. Both of these stoas are dealt with in more detail below in the section on design issues.

Chapter 11

Upper Ceilings and Rafters

Important evidence for the reconstruction of the ceiling and roof of the stoa is provided by two blocks with slanting taenias and slots to take battens. Both blocks have slanting taenias that show the slope and possibly the thickness of the rafters and the slot above the taenia shows the thickness of the battens.

The first block is 0.51 m. in height and 0.473 m. thick. **Fig. 113** The full length is not preserved, but a setting line 0.554 m. from the preserved end, marking the line for the next block to be set above, may mark the mid point of the block. In that case, the block would be ca. 1.108 m. in length. The block preserves a sloping taenia with a height of ca. 0.16 m. and above this, is a corresponding slot 0.07 m. thick and 0.06 m. deep. There is a clamp cutting on top at the preserved end of the block, as well as a pry cutting and setting line for a block above ca. 0.554 m. from the preserved end. The face opposite the side with the taenia is worked smooth and stuccoed. If the taenia height is indicative of the rafter height then the rafters would be 0.16 m. thick, although it is perhaps more likely that the rafter height is greater than that.²⁴⁷ The slot cutting above the taenia is likely for battens, which would presumably be slightly less than 0.07 m. thick. **Fig. 114**

²⁴⁷ See Broneer 1954, 83, where he asserts that the rafters were the same height as the taenia. It might, however, be argued that the taenia height is just suggestive of the rafters and in any case has a function as a projecting ledge for supporting the battens.

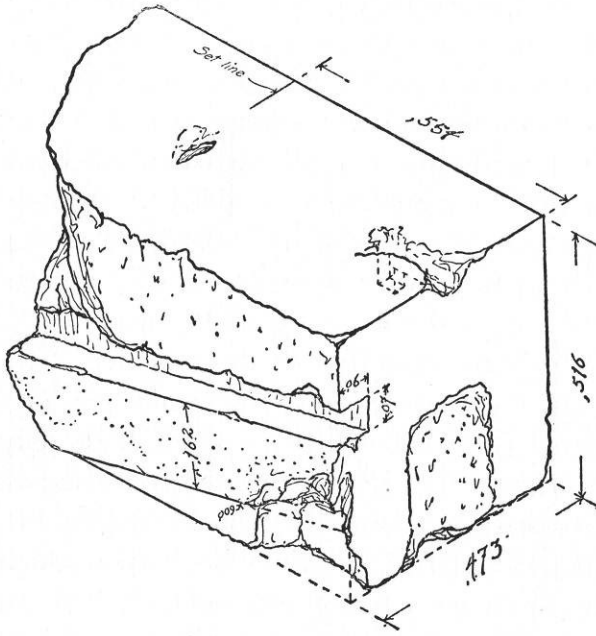

Fig. 113. Block with sloping taenia (Broneer 1954, Fig. 60).

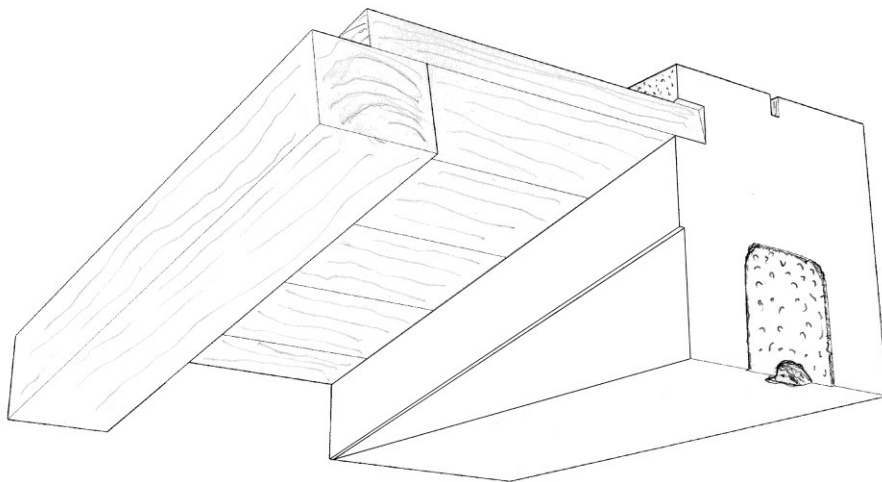

Fig. 114. Reconstruction showing block with sloping taenia, rafters and ceiling boards fitted into slot on block.

One possible place for this block would be in the pediment just in front of the front wall of the backrooms, where it would provide a bed for the battens above rafters sloping down to the front wall of the backrooms, forming a sloping ceiling. **Fig. 115** This would have provided additional support for the roof above the interior colonnade. In addition it would provide a balance for the interior space beneath the rafters in the front half of the building.²⁴⁸ In the reconstruction, the block has been placed in the west wall just south of the interior columns where a ceiling would slope down toward the interior front wall of the rooms.

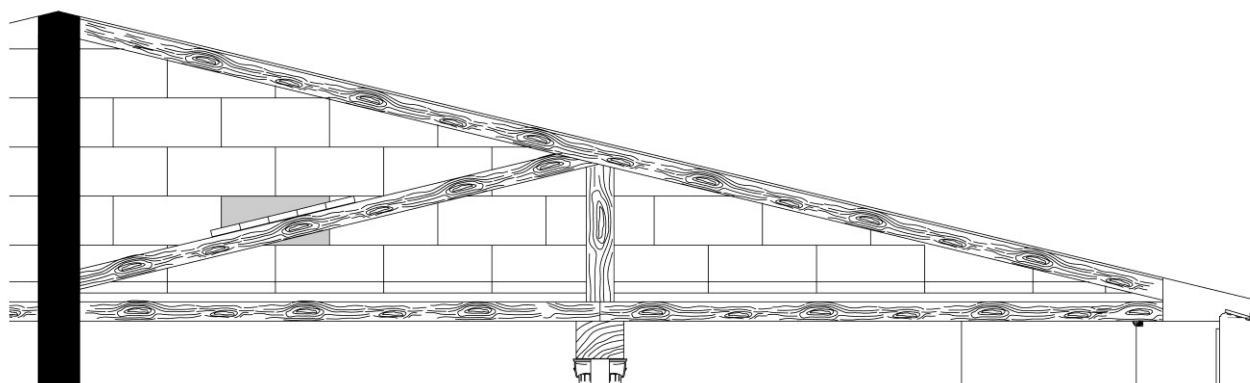

Fig. 115. Position of block with sloping taenia (in grey) in pediment; showing how the block would work with rafters and battens running back down to the front wall of the backrooms. The block fits precisely into the hypothetical rhythm of the pediment blocks.

²⁴⁸ The Stoa of Attalos had a sloping ceiling in the upper storey from the internal colonnade to the front wall of the shops, which creates the illusion that the ridge of the roof is centered above the interior colonnade, when in fact it is above the front wall of the shops.

Sloping rafters would then rest on the interior wall, creating the impression that the roof was centered over the interior columns and sloped down toward the front wall of the backrooms. If horizontal beams extended from the cornice on the front to the front wall of the backrooms, these beams could have been interspersed over every internal column, leaving space between open rather than covered, and the rafters above would have been visible.

Broneer used this block as the main piece of evidence for the idea that the roofline was broken vertically and restored a tile with an upturned edge as support for how his proposed scheme would work.²⁴⁹ He placed this block in the side wall at the back of the stoa, where he surmised a second, lower roof extending the length of the building above the rear compartments and against the two projecting wings. **Fig. 116** The only reason for a second lower roof would be to create a clerestory for lighting the interior rooms, but there is no other evidence for his reconstruction other than the two blocks with slanting taenias and no parallel before or later for such a break in the roofline. In the new reconstruction the roof would extend to the rear wall in one slope.

Even if the upturned edge of the tile that Broneer restores in this position is flush against the wall, there would be no proper way to seal the joint between tile and wall. Mortar (or clay?) would have to be used and would not insure that rainwater would not penetrate to the wooden boards and beams below.²⁵⁰ The most watertight cement would be subject to the possibility of failure in such an extreme position and the joint would require

²⁴⁹ Broneer (1954, 82 and Fig. 60) See Plan XIVb.

²⁵⁰ Broneer notes that mortar is present at the upper joint and along the upper edge of the the upturned side, but does not say where on the upper edge (1954, 87). I have not been able to examine the tile in detail.

constant attention. Although the tile used in the illustration (**Fig. 116**) does exist it is better restored to the sloping edge of the wing extensions at both ends of the building (see roof tile discussion below).

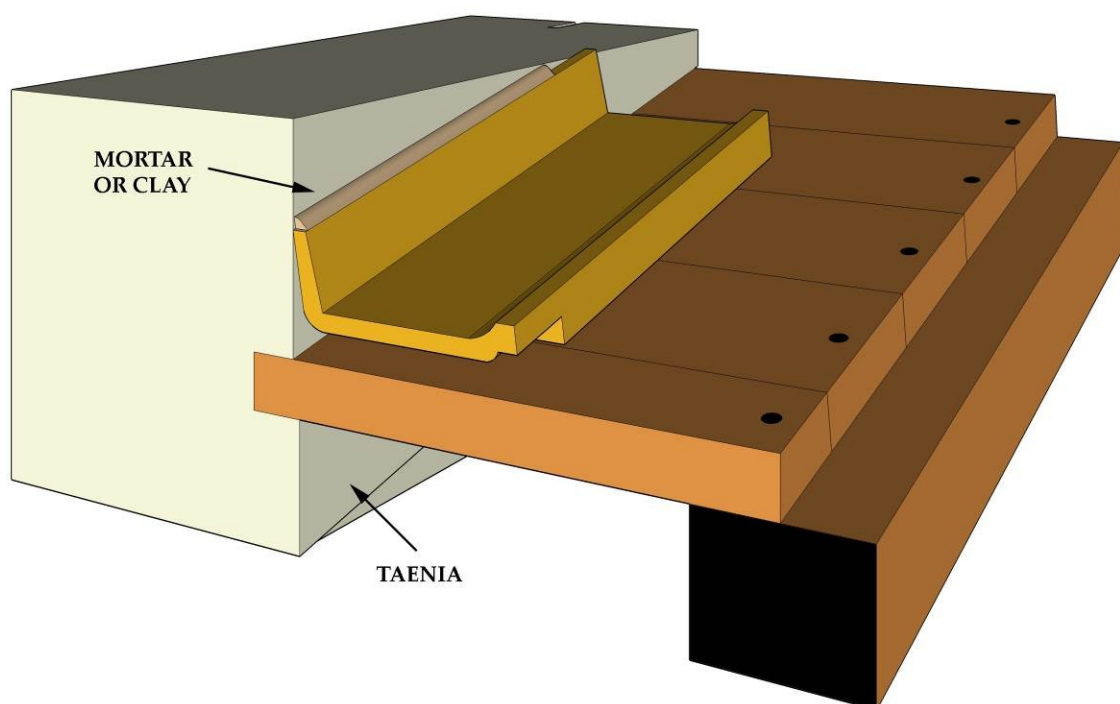

Fig. 116. Reconstruction using block with slanting taenia for lower roof according to Broneer (1954, 82). Showing problem of having to seal joint between tile and wall block.

A second block with slanting taenia was found at the southeast corner of the stoa during excavations. **Fig. 117** The block is 0.353 m. in height and is broken on one end just beyond an L-shaped projection.²⁵¹ Its total preserved

²⁵¹ Broneer says that the height is the same as the cornice height and therefore must go in the cornice level, but 0.353 does not correspond to any measurement of the front cornice height 0.47 at the back and 0.22 at the front from top of molding to resting surface; no back cornice is otherwise preserved from which to obtain

length is just over 0.54 m. It is 0.495 m. in width before the L-shaped projection, which is also broken off a few centimeters past the turn. On top of the block at the preserved end is a clamp cutting, badly damaged. At the bottom is a dowel cutting and just above and to the right of the dowel cutting is another small dowel hole in the end of the block. The block preserves a taenia sloping down toward the end which is broken. The taenia, as preserved, is 0.13 m. high, but if it extends to the top surface it would be ca. 0.16 m. in height at its lower end where the L-shaped section begins. The taenia also turns onto the L-shaped section where it would presumably continue along the top of the wall inside the back room. A small section of the upper edge preserves a drafted margin (as seen in Fig. 117 in section) on the opposite face of the block from the side with the taenia. This would presumably be an exterior face.

This block can be restored at the southwest corner of the projecting east wing. **Fig. 118** Broneer proposed adding a full cornice projecting on the south exterior side of this block which would have continued to the west corner of the east projecting wing, though he did not illustrate it.²⁵²

measurements. It is unclear what Broneer means by this statement, which for him solidified the placement of the block in this position.

²⁵² Broneer 1954, 44.

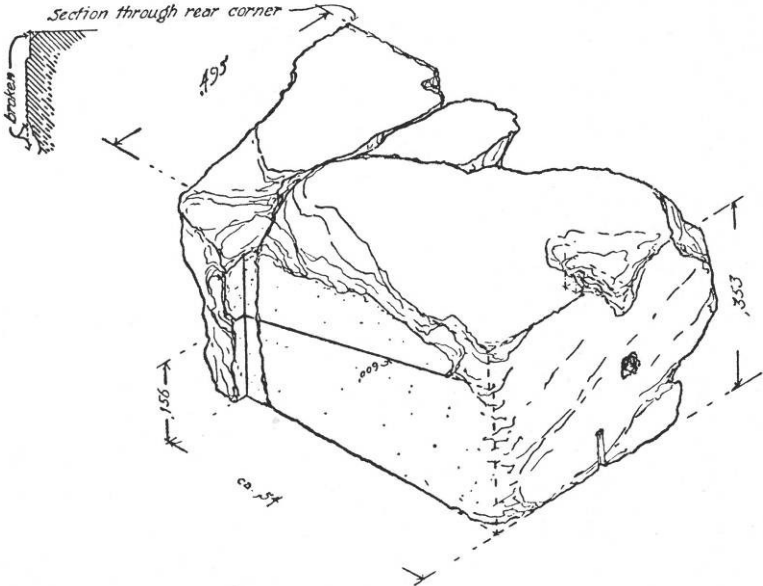

Fig. 117. Corner block with sloping taenia (Broneer 1954, Fig. 21).

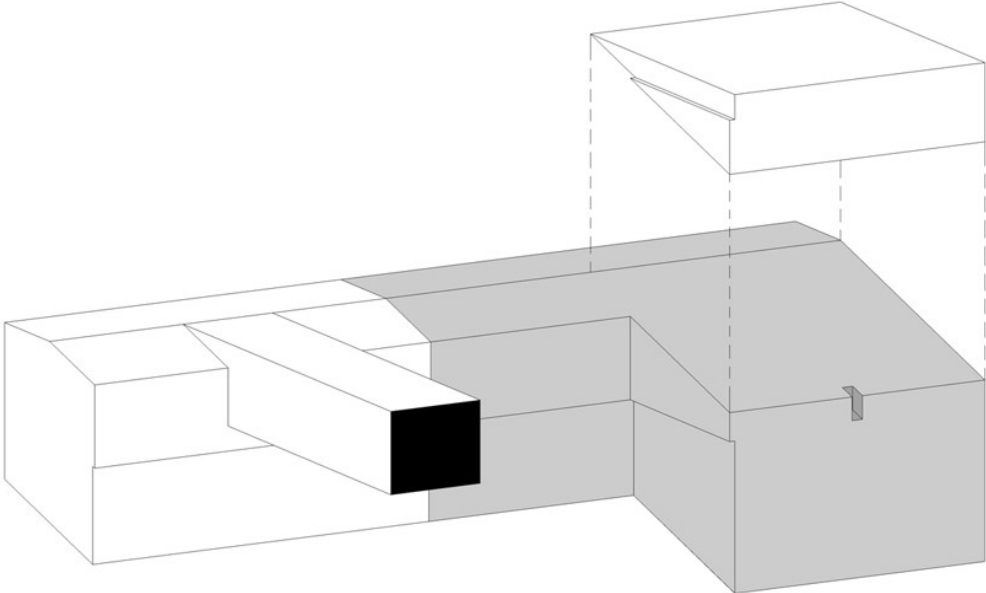

Fig. 118. Isometric of the corner block with sloping taenia restored to position at Southwest corner of Room 1. The corner block is in grey. The hypothetical block above would be sloped on top for the rafters to sit and continue the taenia.

While it is possible that the cornice, or some form of cornice, continued around the south side of the wing, it would not have stopped at the corner without wrapping around it. The preserved west side of the block shows that only a wall face continued back to the inside corner of the wing. The missing projection of the cornice, would have to be restored extending around the southwest corner. Alternatively, if the cornice continued along the flank to the back corner, perhaps it merely extended around the outer, east corner and stopped.

Based on independent evidence from the Classical period, there are a number of ways in which the roof could have been supported. The simplest way would be to have the tiles rest on battens and rafters only. Based on the evidence of the sloping taenia block with the slot cutting for battens, discussed above, it is possible that similar blocks were used for the front and back slope of the roof to hold battens, in which case the roof tiles could have been supported only by battens on top of rafters.²⁵³ The spacing of the rafters would be based on the width of the pan tiles and the spacing of the battens would fall on the length of the pan tiles. Traces of clay on some of the roof tiles suggest that clay was used to seal the joints of the tiles.

On the evidence that some roof tiles had traces of clay attached to them, Broneer assumed that the roof tiles were bedded in a layer of clay on

²⁵³ In the Pinakothek of the Propylaea on the Athenian Acropolis the groove for the battens are set to the pitch of individual roof tiles; that is, they are lightly stepped like the underside of the roof tiles would be, indicating the roof tiles sat directly on top of the battens. In the Erechtheion building inscriptions rafters and battens are mentioned, without mention of any other sheathing (see Hodge, 1960, 68-69). Battens and rafters alone are restored in the Temple of Hera at the Argive Heraion (Pfaff 2003, 121-122).

top of a continuous layer of decking.²⁵⁴ This type of construction would not only add an additional amount of weight on the rafters, but the whole apparatus of decking and clay would leave less space for the rafters, which would have to be reduced in height and, correspondingly in strength, needed to support the clay and wooden decking.²⁵⁵ **Fig. 119**

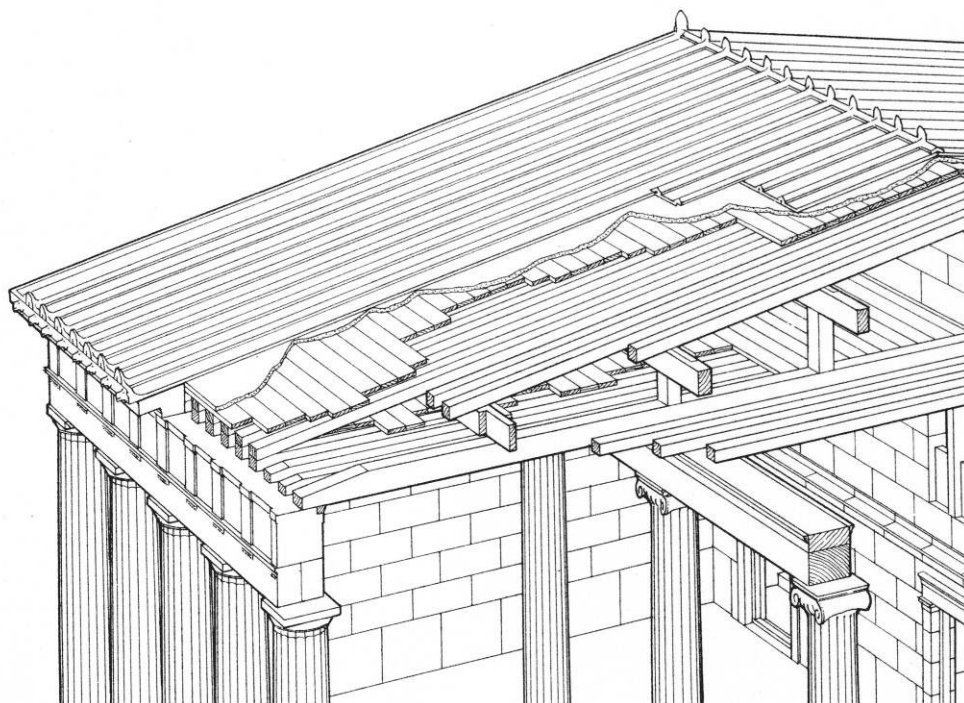

Fig. 119. Perspective showing roofing system proposed by Broneer (Drawing by Piet de Jong, illus. frontispiece to Broneer 1954).

²⁵⁴ Roofing with a layer of clay and reeds underneath, on top of battens and rafters is sometimes shown on the basis of two inscriptions (The Arsenal and the long walls in Athens), but after a short period of time the reeds would not keep the clay from falling through the openings in the battens. See Hodge 1960, 65-67 for discussion of this problem and that the clay referred to is probably for sealing the joints, not as a continuous layer, as can be seen in modern tile roofs with either clay or cement.

²⁵⁵ See Hodge (1960, 65-67) for the problems of reading the two inscriptions which mention clay for roofing (IG², II, 463 referring to the Gallery of the Walls; IG², II, 1668 referring to the Arsenal at Athens). Generally, it is not clear how the clay was used. As Hodge says, a clay layer would make more sense for Laconian tiles to seat them. Corinthian tiles, being flat, need no such bedding (p. 67). A layer of clay with decking on top of rafters is shown for the South Stoa at Corinth in the frontispiece to Broneer 1954.

More probably, only battens and rafters should be restored as the support for the roof tiles due to the height clearance at the back of the geison (see Fig. 75 above). From a conservative standpoint, it can be argued that this is all that would be needed. The rafters would need to be spaced on center every 0.585 m. (0.59 m.) to fall beneath the edges of the pan tiles. The battens would sit perpendicular to the rafters on top of them, and could be spaced on center every ca. 0.62 m. (tiles ca. 0.68 m. in length minus overlap of ca. 0.06 m.) to support the back edge of each pan tile, or the battens could have been set side by side, abutting each other, so that the spacing would not need to follow that of the tiles. The slot for the battens on the sloping taenia block is continuous, indicating the battens were probably laid as continuous decking for the tiles, even though this would make the roof heavier and the additional material more expensive.

The dimensions of the battens and rafters, as discussed above, can be compared with other Classical and Hellenistic buildings where this evidence exists. In the South Stoa, the rafters were not bedded on the backs of the geison blocks. Instead, they must have rested on top of the backs of the frieze blocks. The heights of both must coincide with the full height of the back of the geison blocks. The battens can be estimated to have a thickness of ca. 0.02-0.04 m. and a width of at least 0.17-0.18 m. although they could be almost any width if the decking is continuous.²⁵⁶ The back height of the geison blocks of the front façade is ca. 0.427 m minus the thickness of the battens (ca. 0.04

²⁵⁶ The battens of the Classical Temple of Hera at the Argive Heraion were ca. 0.17 m. wide and a minimum of 0.025 m. thick (Pfaff 2003, 121).

m.), which would leave ca. 0.387 m. for the height of the rafter beams. A thickness of ca. 0.40 m. is well beyond what would be needed structurally.²⁵⁷

Tie Beams

Tie beams, or crossbeams, can be plausibly restored to the roof construction as well, either horizontal or sloping underneath the rafters and battens.²⁵⁸ At the back of the frieze blocks on the top surface there are cuttings for dowels, which Broneer surmised were for geison blocks. This would require that some geison blocks extended as far back as the dowel holes, however the evidence suggests the geison blocks did not extend that far back and there would be no reason for some to do so. A more plausible explanation for these dowels would be that they are for securing horizontal wooden crossbeams, spaced so that a crossbeam fell above every exterior column with room for two crossbeams in between, based on the placement of dowel cuttings on top of the frieze.²⁵⁹ **Fig. 120** Broneer had restored crossbeams, but then made every fourth beam larger to support the upright beams that hold up the rafters (see Fig. 119). The larger horizontal beams then must be shaved down excessively at their outer ends to accommodate

²⁵⁷ The general practice in Greek architecture is usually to have rafters square in section, though they can also be wider than deep (See Hodge 1960, 92). The Arsenal Inscription calls for rafters ca. 0.37 m. in width, but only 0.19 m. in height (based on Hodge's reading of the measurements [ibid, 94]). The rafters in the Stoa of Attalos are restored as having a double beam construction ca. 0.30 m. in total height, one on top of the other, at the front of the building. The reason they are double is due to the "false" drop rafters, beneath the rafters holding up the roof. In actuality these double beams would add additional support for the roof and transfer some of the load back to the shop wall. Compare also the rafter beam cuttings in a frieze block from the Asklepieion at Corinth, which are ca. 0.40 m. wide (Roebuck 1951, 31, Fig. 7 and plate 10, 1 and 6).

²⁵⁸ See Coulton (1976, 157ff.) for a discussion of Crossbeams.

²⁵⁹ See Broneer 1954, Plate XIVb. See section on the frieze blocks, above, for further discussion.

the rafters, thus reducing their strength. By removing the layer of clay and unnecessary extra layer of decking, however, the cross beams and rafters could fit comfortably at the back of the geison. Also, it would not be necessary to have as many crossbeams per bay, as the weight they support would be significantly reduced. The cross-beams would provide support for the transference of load on the front colonnade. They would also provide some stabilization for the interior colonnade and balcony.

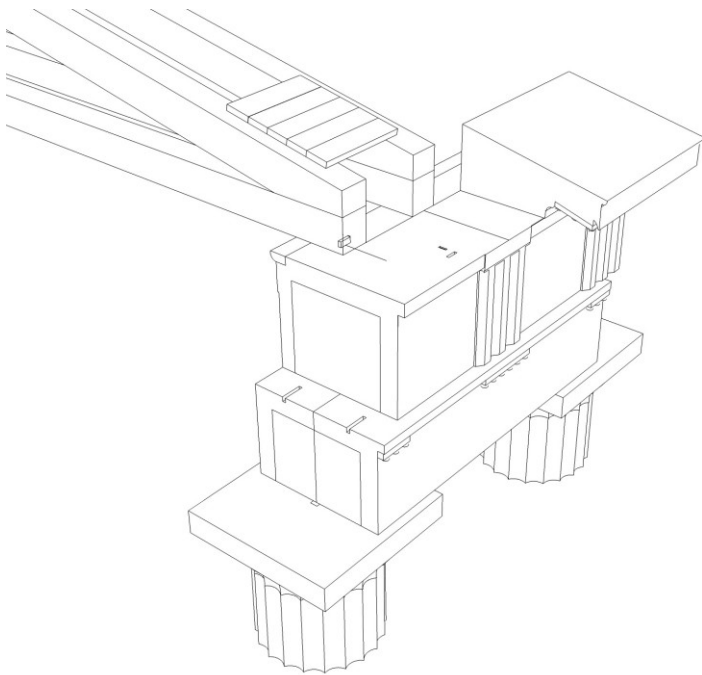

Fig. 120. Perspective of entablature with hypothetical restoration of horizontal tie-beams. Dowel on top of the frieze toward front is for the geison.

Chapter 12

Roof Revetment

The roof tiles and sima of the South Stoa are made of terracotta and are of the Corinthian type.²⁶⁰ A large number of fragments are preserved, most being found in the stoa wells, where they were dumped sometime after the building was at least partially destroyed.²⁶¹ The preserved fragments provide evidence for the dimensions of the tiles and the sima and show how the roof looked in its initial phase. A relatively small proportion belong to replacement tiles in the Greek period while others probably belong to the post-Mummian refurbishment of the stoa.

Horizontal Sima

The outer visible portion of the sima of the South Stoa consists of a small fascia surmounted by a taller fascia, crowned by an ovolo. The horizontal sima has lion-head spouts, flanked by tendrils consisting of a double spiral design springing from acanthus leaves. **Fig. 121** The crowning ovolo is decorated with an egg and dart. Flanking either side of the lion heads are double spiral tendrils in relief beneath acanthus leaves. The lower projecting edge is decorated with a meander and cross-squares. The bottom

²⁶⁰ See Broneer 1954, 83-88. For discussion of workshops in the early Hellenistic period which produced similar roof tiles, see especially Heiden 1987.

²⁶¹ Edwards 1975, 225ff. Deposit 97, Well IV is interesting in that it has broken roof tiles possibly related to a pre-Mummian destruction.

of the outer edge of the sima, which would have projected beyond the crown of the geison, is decorated with a bead and reel pattern in reserve.²⁶²



Fig. 121. Horizontal sima and antefixes.

The horizontal simas are in sections measuring 0.62 m. in length, matching the width of the pan tiles, which is incommensurate with the axial spacing of the Doric colonnade (2.34 m). Therefore, starting from the fifth triglyph in from the end, the lion head spouts fall only over every ninth triglyph instead of following the rhythm of the colonnade. The practice of having a

²⁶² Broneer 1954, 84-85, provides a detailed account of the sima. On the decoration, he notes that the squares are checkered, alternating black and reserved in the corners. Meanders with cross squares are standard ornament for the lower fascia on terracotta simas of the Classical period. See Pfaff, 2003, 189. At Sikyon, there is a similar sima with lion head water spout attributed to the gymnasium in the agora, dated to the early third century B.C. This sima is on display in the museum, but has not yet been published. The lionshead spout is similar enough to those of the South Stoa at Corinth to suggest that they come from the same mold.

lateral sima and roof tiles that do not synchronize in a simple way with the colonnade is not uncommon in Greek architecture and in fact is the case on many of the best executed temples known.²⁶³ One explanation for this occurrence would be if the production of roof tiles was standardized to the extent that roof tiles were produced in a limited number of sizes.

Raking Sima

Sections of raking sima are preserved which probably belong to the east pediment.²⁶⁴ **Fig. 122** The sima sections are 0.595 m. in length. The sections consist of three units of decoration, each 0.212 m. in length. The original length of each section of the sima should therefore be 0.636 m., but the preserved sections show evidence of trimming after firing which has cut off the lotus bud at the edge of the face.²⁶⁵ The lower fascia has a meander and cross-squares for decoration.

²⁶³ See Roux 1961, 106, 211; Pfaff 2003, 129. An example is the Temple of Zeus at Nemea (Hill and Williams 1966, 17).

²⁶⁴ These sima fragments were found in wells at the east end of the building, according to Broneer (1954, 85).

²⁶⁵ As Broneer points out, this was probably due to the fact that they were fabricated to a standardized length which then required trimming (1954, 86).



Fig. 122. Section of the raking sima.

The cyma reversa is decorated with a lotus and palmette band. The trend at the end of the 4th century toward narrower and taller palmettes is ignored and the earlier trend of broader leaves is retained.²⁶⁶ The crowning ovolo is decorated with an egg and dart.

Since the lateral and raking simas have different profiles, there is an awkward transition at the corner. A possible way that this was handled is shown by a corner sima from another Hellenistic building at Corinth, where the plastic decoration stops at the lion head and painted palmettes take over on the other side just before the corner.²⁶⁷ **Fig. 123** Although there are

²⁶⁶ See Roebuck 1994, 47 on this phenomenon. This fits the trend of the raking sima profile, which is also like earlier profiles as noted below in the section dealing with moldings.

²⁶⁷ This corner sima is discussed by Roebuck 1994, 49. It was found in excavations to the north of Temple Hill by De Waele and published by him in 1931 (417, Fig. 10).

numerous examples of buildings where the lateral and raking simas have different profiles, it is puzzling as a solution.²⁶⁸



Fig. 123. Corner sima from a Hellenistic building at Corinth showing transition from plastic decoration to painted decoration (De Waele 1931, Fig. 10).

²⁶⁸ See Pfaff 2003, 122 on this phenomenon, and note 10 for a full list of temples. Pfaff notes that it was standard on nearly all 4th century mainland Greek temples to have different profiles for lateral and raking simas.

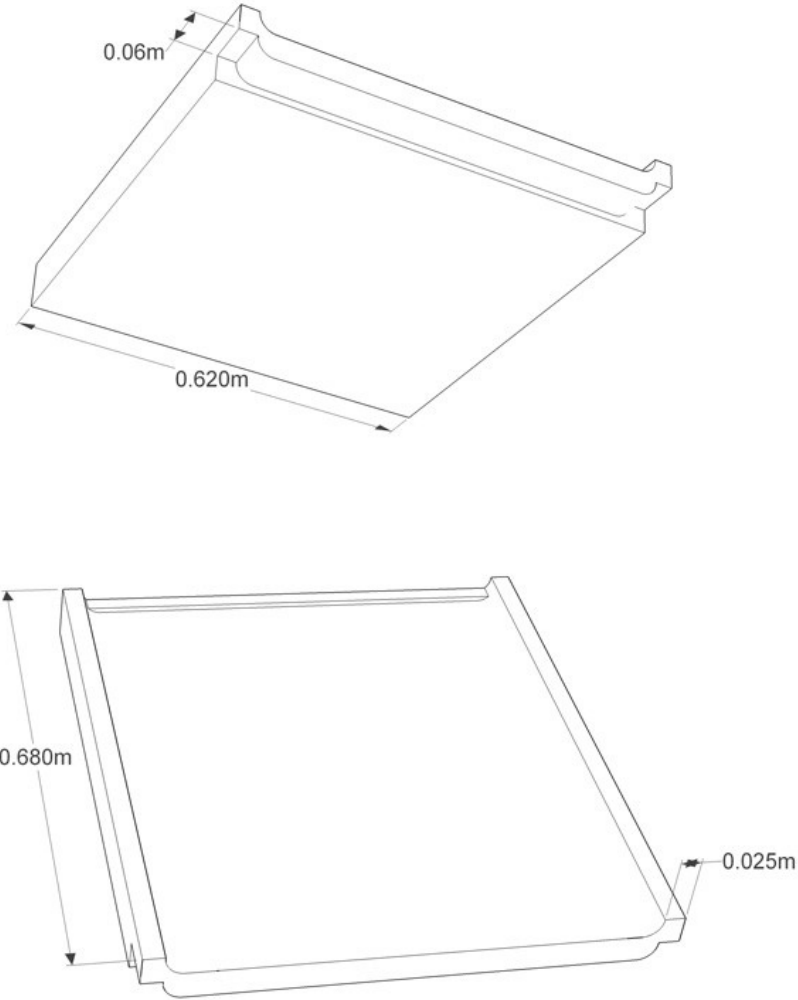

Fig. 124. Restored pan tile of the South Stoa.

Pan Tiles

The largest percentage of surviving pan tiles measure ca. 0.68 m. in length and ca. 0.59 m. in width. **Fig. 124** Broneer noted that there are pan tiles as large as 0.78 m. in length and 0.70 m. in width, which may or may not belong on the building.²⁶⁹ Since the sima is 0.62 m. in length, the pan tiles would have a margin of ca. 0.03 m. between adjoining tiles. There is a slight lip one to two centimeters wide at the top back edge of each tile to prevent rainwater from seeping back and down into the underlying woodwork. There is a rebate six to eight centimeters wide on the underside of the lower edge where the tile overlaps and rests on top of the next tile down the slope.²⁷⁰ The tiles are 0.025-0.04 m. thick in the middle, and at the upturned edges along the sides the thickness is approximately double. There are no holes in the tiles to fasten to the wood planking, but the interlocking system of rebates would prevent slippage.²⁷¹

Among the pan tiles found was a unique piece with upturned edge that is half the width of a normal pan tile. Broneer originally used this tile in his argument for a broken roofline at the back of the building. As mentioned above in the discussion of the wall block with a sloping taenia, this tile finds a better place along the back inside edge of the roof where the first and last rooms form wings. Here the tile would serve as a simple raking sima along the back slope of the roof where it is exposed on this inside corner. **Fig. 125**

²⁶⁹ Broneer 1954, 83. Broneer's discussion of the roof system is for the most part followed here. No new data has come to light which would alter his findings.

²⁷⁰ The difference in size between the ridges and grooves of the pan tiles would allow for variation in the size of the tiles (Broneer, *ibid.*). The maximum allowance would be ca. 0.07 m.

²⁷¹ Broneer (*ibid.*) notes the gentle slope of the roof would prevent slippage in any case.

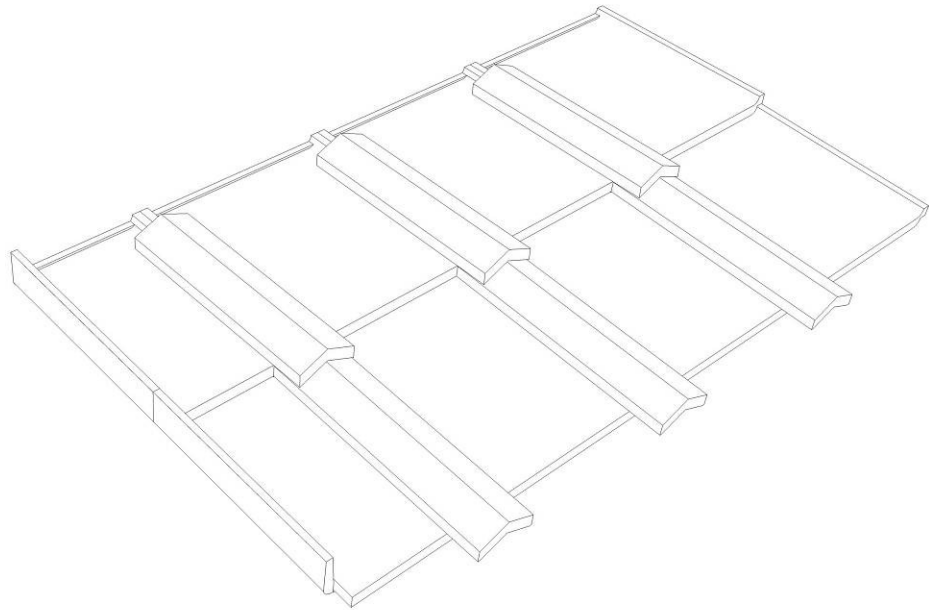

Fig. 125. Hypothetical reconstruction of half-tiles with upturned edge along the inner raking edge of the roof for the two projecting wings at the back of the stoa.

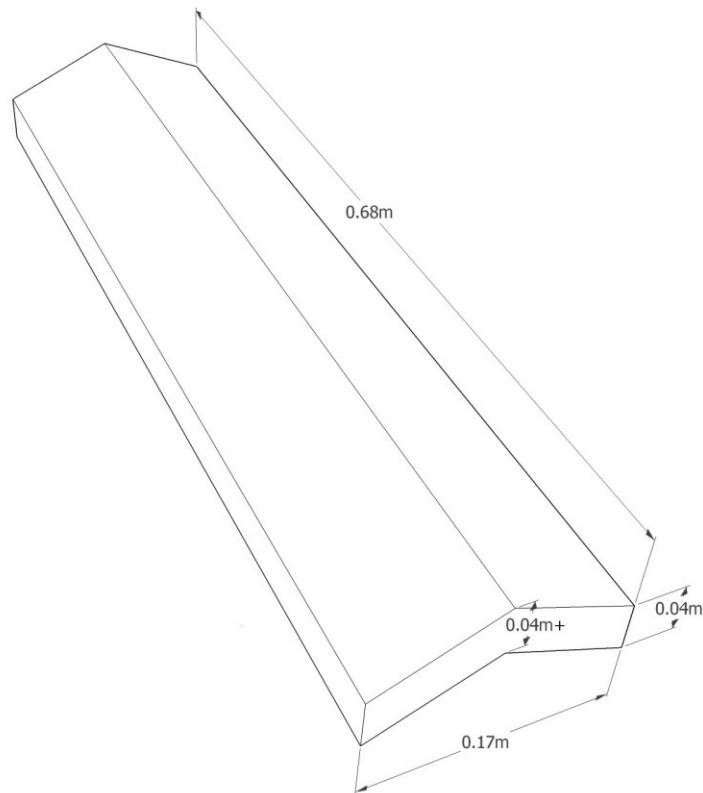

Fig. 126. Perspective of original cover tile, showing dimensions

Cover Tiles

The cover tiles of the South Stoa are of the Corinthian type and measure 0.17 m. in width.²⁷² **Fig. 126** To accommodate the six centimeter overlap of the pan tile above and to project beyond the pan tile the same amount the cover tiles would have a length of ca. 0.68 m. The system of cover and pan tiles working together is illustrated in **Fig. 127**

²⁷² Broneer 1954, 86, 88.

CORINTHIAN ROOF TILES

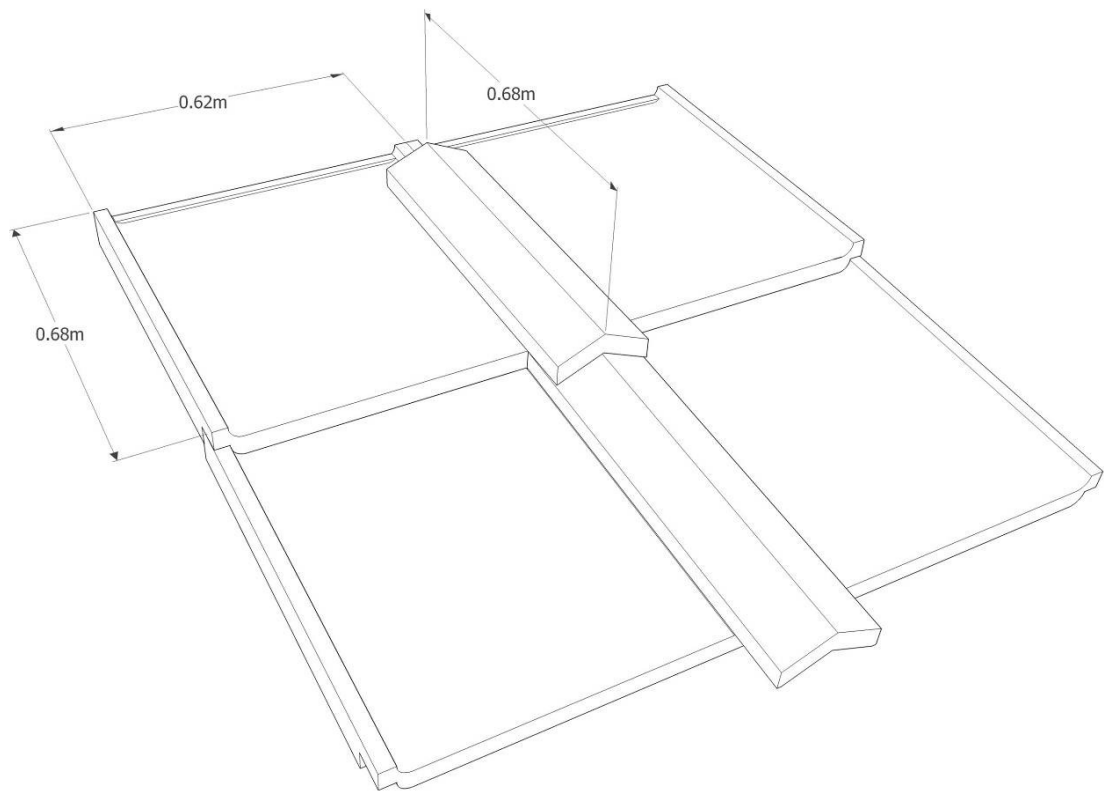

Fig. 127. Perspective showing roof tile system

Recovered also from the same well deposits of normal tiles are cover tiles with projecting ears at one end of the tile, which would presumably interlock with the pan tile above or below. **Fig. 128** Since the pan tiles of the South Stoa overlap each other and the back edge of the cover tile would normally butt up against the front edge of the tile above if its back edge is flat, there seems to be no reason for the projecting ears and therefore these special cover tiles may go on some other building. Broneer suggested that the ears would fit against the lower edge of the pan tile, but he does not illustrate

how this would work; nor does this seem possible given the way the pan tiles are constructed.²⁷³

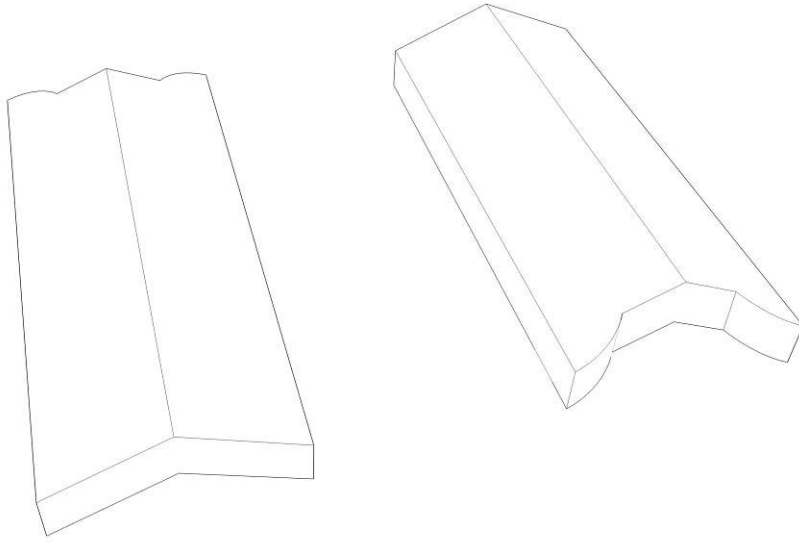

Fig. 128. Terracotta roof tile with projecting ears.

²⁷³ Broneer 1954, 86 and Plate 22.4. It remains unclear how this special cover tile might have worked. The existing examples of tiles show no need for the ears. The cover tiles would abut against the pan tile snugly and in no way is there a tighter fit between cover tile with ears and existing pan tiles.



Fig. 129. Perspective view of sima cover tile with antefix.



Fig. 130 Antefix attached to lateral sima cover tile.

Sima Cover Tiles and Antefixes

The cover tiles at the edge of the eaves, covering the joints of the sima, carry attached antefixes of a molded and painted palmette with eleven leaves and double-spirals that end in tendrils. **Fig. 129** Between the spirals are half palmettes flanking a central lotus bud turned upside-down. **Fig. 130** Very similar antefixes were found in the Asklepieion at Corinth and at Perachora in the L-shaped stoa, both of which are good evidence for a late 4th century date.²⁷⁴

Ridge pan tiles and Cover Tiles

The ridge pan tiles are ca. 0.59 m. in length and 0.225 m. in width. Ridge cover tiles were placed on top of the ridge pan tiles to cover the joints of the pan tiles. **Fig. 131** The cover tiles have attached palmettes with painted decoration, not molded, of a palmette in reserve against a black background.

²⁷⁴ For Perachora examples, see Coulton 1964, 127, Fig. 13, Pl. B.

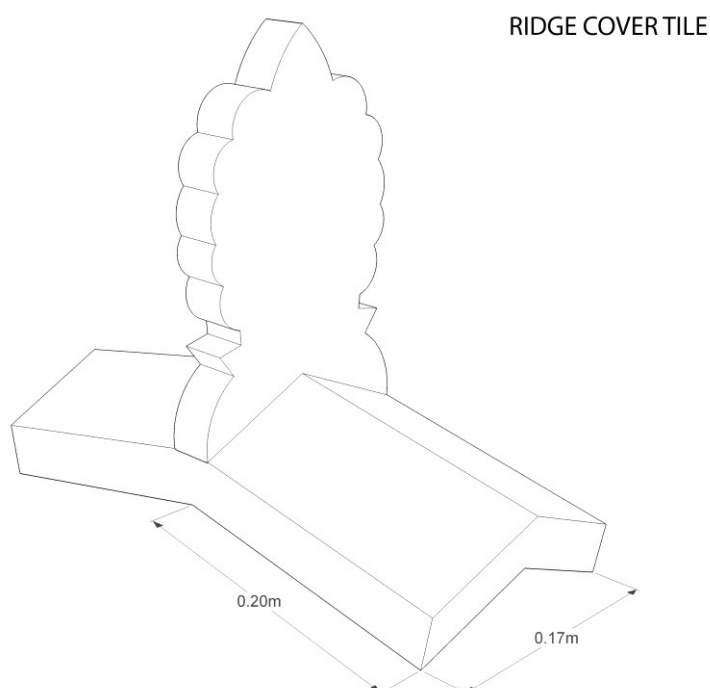

Fig. 131. Perspective view of ridge cover tile with dimensions.

Replacement Elements

There are a large number of sima fragments, found in association with the roof tile material discussed above, that are different from the original Greek sima and Broneer assumed these were replacements for the Greek sima after it had fallen into disrepair. It is also possible that they go on other buildings, although at this point it is impossible to tell. The sections are ca. 0.58 m. in length, 0.04 m. less than the “normal” length of the Greek sima, although four sections would equal the joints of an interaxial span ($0.58 \times 4 = 2.32$ m.).

Broneer hypothesized that the roof was entirely replaced during the first period of Roman repairs as the shop wells contained much of the roof tiles belonging to the initial phase of the stoa as well as original raking sima

and ridge palmettes.²⁷⁵ This debris contained almost no Roman material, suggesting to him that it was deposited early in the Roman period. A full analysis of the roof material and what it may say about refurbishment or repairs after the initial phase of construction of the stoa is outside the scope of this discussion and any more speculation cannot be made at this point.

²⁷⁵ Broneer 1954, 101.

Chapter 13

Moldings

The moldings used in the South Stoa reflect trends of the latter half of the 4th century B.C. for Doric architecture of the Mainland and Peloponnesos. The basic repertoire of moldings usually relegated to temples is used, making the building an especially well appointed one, which distinguishes the South Stoa from other stoas of this time period.

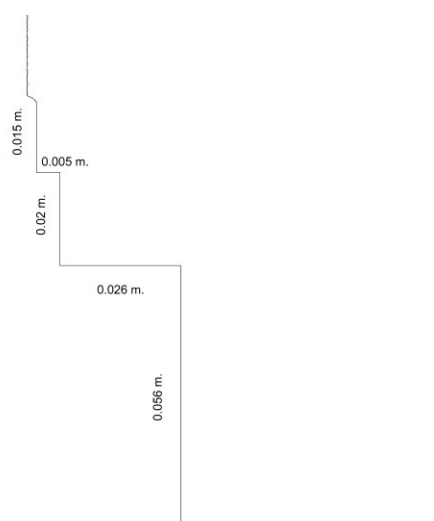

Fig. 132. Profile of triple banded drafting of krepidoma and toichobate blocks.

The top two steps of the krepidoma have a continuous triple banded, and recessed compound molding, which is common in Peloponnesian architecture of the 4th century B.C.²⁷⁶ The molding is continuous across the

²⁷⁶ See section above for the krepidoma molding. Buildings with the same molding on all three steps of the krepidoma include the Temple of Hera at the Argive Heraion (Pfaff 2003, 175); the Temple of Zeus and the Metroon at Olympia (Olympia II, Pls. XI, XXIV-XXV); the Temple of Athena Nike (Orlandos 1947-1948, p. 10, Fig. 7); the Stoa Poikile in Athens (Shear 1984, p. 5); the Temple of Apollo at Bassai (Haller von Hallerstein 1976, p. 4 of facsimile; Bassitas I, pp. 172-173, Fig. 16; III, Pl. 40:a; IV, Pl. 20); the 4th century Temple of Apollo at Delphi (Courby 1927, p. 13, Pl. V). Other

north front beneath the colonnade wrapping around both sides and extends to the back of the building, stopping just before the blocks of the south corners.

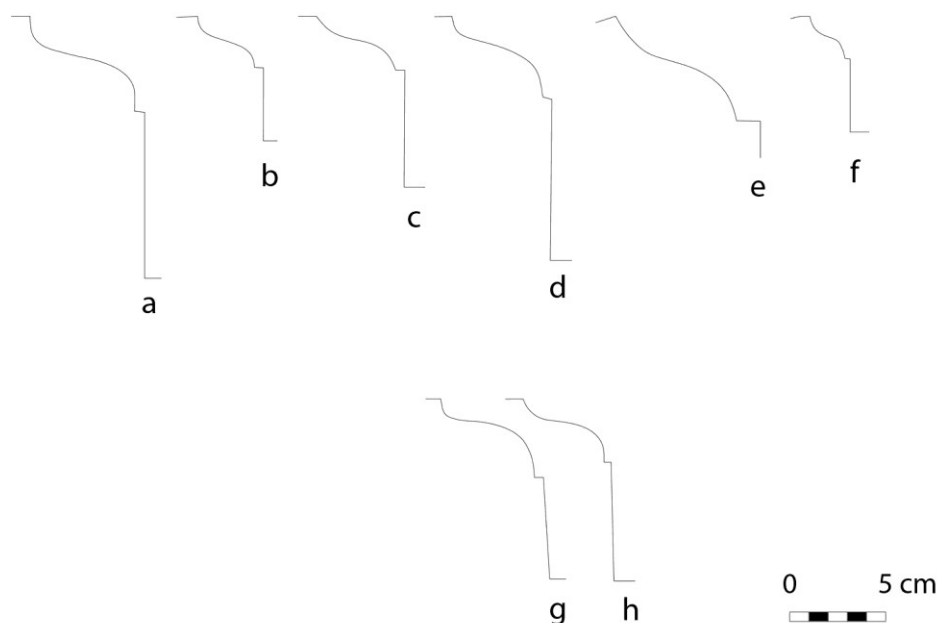

Fig. 133. Geison soffit Moldings comparison. a. Temple of Apollo, Delphi; b. Temple of Athena, Delphi; c. Thersilion, Megalopolis (raking); d. Temple of Athena Alea, Tegea; e. Temple of Zeus, Nemea; f. L-shaped stoa at Perachora; g. South Stoa, Corinth (raking); h. South Stoa Corinth (horizontal)

Soffit Molding of the Lateral and Horizontal Doric Geison

A cyma reversa is used for the soffit moldings of the horizontal and raking geisa of the stoa. **Fig. 133 g.** The horizontal cyma reversa measures ca. 0.033 m. in height and 0.042 m. in depth. The projecting depth is therefore more than the height and the lower curve is almost twice the height of the

buildings in the Peloponnesos that have continuous moldings on the krepidoma include the Temple of Asklepios at Epidauros (Roux 1961, 91, Fig. 28); Temple of Athena Alea at Tegea (Dugas 1924, Pls. xv-xviii, xxx); Temple of Zeus at Nemea (Hill and Williams 1966, Pl. xiii); Philippeion at Olympia (Schleif and Zschiezschmann 1944, Pls. 3, 5); Echo Colonnade at Olympia (Koenigs 1984, Pls. 26, 72).

upper curve. The proportions are most like those of the 4th century B.C., being less tall and projecting more than 5th century examples on the whole.²⁷⁷

The cyma reversa soffit has almost the same depth but slightly more of a vertical swing to the curve than the soffit of the Temple of Zeus at Nemea. The profile, however, is perhaps most similar to the Temple of Apollo at Delphi, but the depth is slightly greater.

Clearly, the profiles of the 4th century do not fall into a neat evolutionary pattern, but slight variations do seem to follow a regional pattern, with close comparisons between Corinth, Nemea, Tegea and Delphi especially. This suggests the possibility of assigning carving to workshops in some cases, rather than showing a clear cut stylistic development within the 4th century. In the Peloponnesos, at Nemea, Tegea and Corinth, the profile has a noticeably deeper swing, beginning with the top curve. The molding of the Temple of Apollo at Delphi would fit in with these three because it was completed by a Corinthian workshop and it probably influenced the Temple of Athena there as well.²⁷⁸

²⁷⁷ See Shoe 1936, 71, XXX, 28, 29 for the profiles of the South Stoa. Shoe (1936, 68) notes that for the cyma reversa geison soffit profile it is difficult to trace a definite development, but general changes of height and depth are noticeable. An example of 4th century proportions found in the 3rd century occurs in the Portico of Philip on Delos (Shoe 1936, XXXI, 45). For the other moldings: Temple of Apollo, Delphi (Shoe 1936, Pl. XXX, 20); Temple of Athena, Delphi (Shoe 1936, Pl. XXX, 21); Thersilion, Megalopolis (Shoe 1936, Pl. XXX, 23); Temple of Zeus, Nemea (Shoe 1936, Pl. XXX, 30); Stoa, Perachora (Shoe 1936, Pl. XXXI, 27).

²⁷⁸ It might be that the geison soffit molding would experience a high degree of variation (as opposed to following a stylistic development) due to different material on which the element was carved (marble versus limestone) and the application of stucco or not, because of its transitional position. Other moldings would be subject to this variety of material and variation of form.

Doric Geison Drip

The geison drip of the outer lower edge of the geison face is stylistically closest to those of the second half of the 4th century B.C. with the Classical form of curving undercut, but the fascia stops above the nose, as in other well attested 4th century examples.²⁷⁹ **Fig. 134** The tip is ca. 0.008 m. wide. The undercut is ca. 0.035 m. wide and ca. 0.04 m. deep.

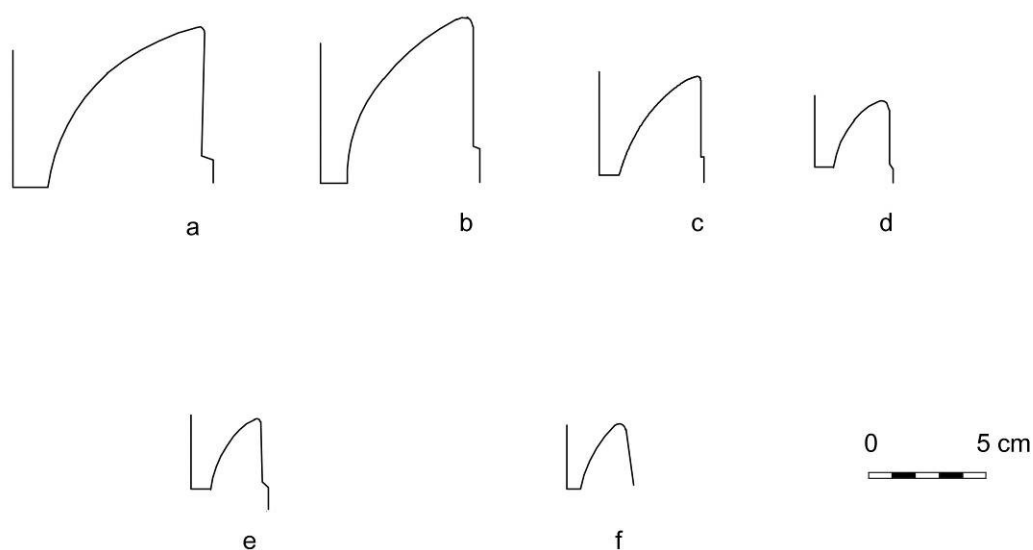

Fig. 134. Doric geison drip. a. Temple of Zeus, Nemea. b. Temple, Stratos. c. South Stoa, Corinth. d. Choregic monument of Nicias, Athens. e. Asklepieion, Corinth, 2nd half 4th c. f. Stoa at Perachora.

If we compare other 4th century examples of the geison drip there are some distinctions worth noting. The undercut on the South Stoa drip curves slightly less than at Nemea (**Fig. 134:a**) and Stratos (**Fig. 134:b**), and is less broad than at Nemea, becoming almost as broad as it is deep, like the drip at

²⁷⁹ See Shoe 1936, 159, LXXIII, 33.

Stratos. The fascia of the geison of the South Stoa at Corinth ends above the tip, that is, the tip extends below the level of the top edge of the front of the mutule, as at Nemea and Stratos and other fourth century examples. In the Asklepieion example from Corinth (**Fig. 134:e**), dated to the second half of the 4th century B.C., the fascia from the drip is slanted slightly inwards and ends on level with the tip. This, however, is also seen far afield in the Choregic Monument of Nicias in Athens (**Fig. 134:d**), but the curve of the undercut is similar in all three, showing that slight variations can exist locally, while some details are shared by buildings in a wider regional sphere. The drip from Perachora (**Fig. 134:f**) has a similar curve to the undercut as well, but the fascia slopes greatly. Later, the third century form of an inverted notch with straight sides that slope becomes the norm.²⁸⁰

²⁸⁰ For Nemea (Shoe 1936, 159, LXXIII, 31); Stratos (Shoe 1936, 159, LXXXIII, 32); Athens, Choregic Monument of Nicias (Shoe LXXIII, 34); Corinth, Asklepieion, 2nd half 4th century B.C. (Shoe LXXIV, 4); Perachora, Stoa (Shoe LXXIV, 7). For the 3rd century form see Shoe 1936, 159, LXXIV, 20).

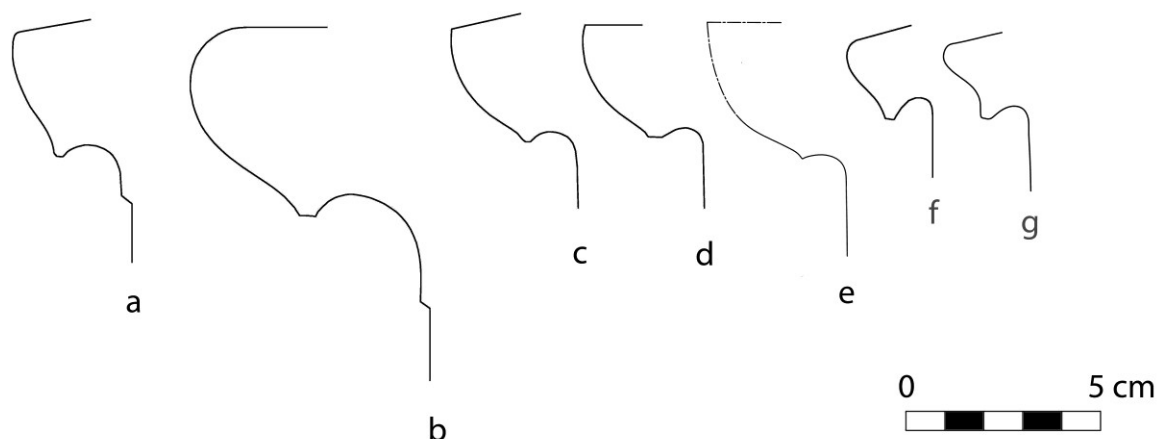

Fig. 135. Comparison of Doric Hawksbeak. a. South Stoa, Olympia. b. Temple of Apollo, Delphi (4th-century). c. South Stoa, Corinth (horizontal). d. South Stoa, Corinth (raking). e. Thersilion, Megalopolis. f. Asklepieion, Corinth. g. Stoa, Perachora.

Doric Geison Crowning Molding

The Crowning molding of the Doric geison is the cyma reversa type hawksbeak.²⁸¹ **Fig. 135** It is most similar to the crowning molding of the geison of the portico of the Thersilion at Megalopolis and much less pronounced than the crowning molding of the geison at Perachora.²⁸² The chronological sequence places the South Stoa molding before the molding at Perachora.²⁸³

The geison crowning molding of the South Stoa belongs to Shoe's Form V type. This form is found in only a few buildings in the Peloponnesos and in the 4th century Temple of Apollo at Delphi. The more typical geison crown molding for the 4th century in the Peloponnesos is Shoe's Form I type,

²⁸¹ See Shoe 113-14, Pl. Iv. 10-11.

²⁸² For the Thersilion at Megalopolis see Shoe (1936, 114, Pl. Iv. 12). For Perachora see Shoe (1936, 74, 115, Pl. Iv. 25).

²⁸³ See Coulton 1964, 126.

which is a continuation of the 5th century form and it runs from the beginning to the end of the century.²⁸⁴ This would suggest that the form V type of hawksbeak, which first appears at Delphi, was then repeated at Corinth via Corinthian masons or workshops involved in activity at Delphi.²⁸⁵

Sima Moldings

The simas of the South Stoa are represented by the lateral simas of the North façade, which have a lion head water spout, and the raking sima, which is a cyma reversa profile surmounted by a cavetto and vertical fascia above. The lateral sima has a vertical profile with projecting tendrils sprouting from acanthus leaves on either side of the lion head spout, surmounted by an ovolo. **Fig. 136**

²⁸⁴ For example in the Temple of Asklepios and Artemis at Epidauros, Temple of Athena Alea at Tegea and the Temple of Zeus at Nemea.

²⁸⁵ The connection between Corinthian limestone and masons at Delphi concerning the foundations was already discussed above.

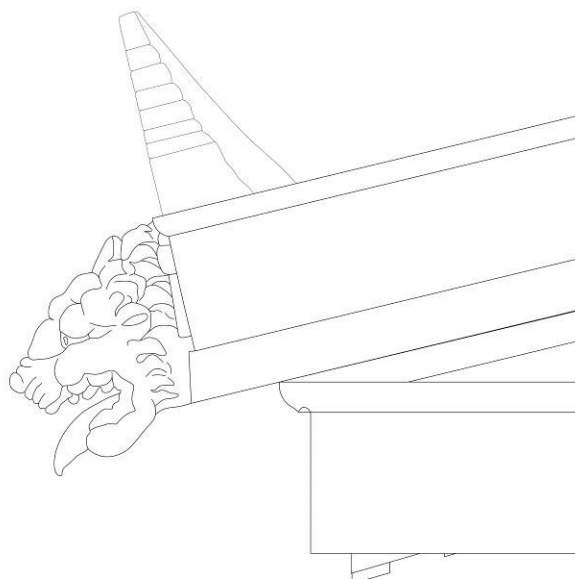

Fig. 136. Elevation showing the profile of the lateral sima of the North façade.

The raking sima profile can be compared with the profiles of the sima from the Asklepieion at Corinth with which it is almost identical. **Fig. 137** Roebuck refers to these two profiles as being reminiscent of earlier forms in the treatment of the cyma reversa which is quite pronounced, unlike other contemporary examples (such as c) in Fig. 137) that she dated to the latter part of the 4th century.²⁸⁶

²⁸⁶ See Roebuck 1994, 47-48. The precision of her dating for the form of c. in Fig. 137 is questionable. In light of the fact that the palmette decoration on the raking sima of the South Stoa also looks “archaizing” (as noted by Roebuck) there might be grounds to question the attribution of this sima to the South Stoa, but the fragments otherwise seem to fit the stoa and their decoration is also otherwise similar to the lateral sima. Roebuck questions whether it might be the case that the tile makers copied earlier tiles at Corinth (48), but I wonder if it might be that the sima was made earlier and happened to be available for the South Stoa builders. This might explain the trimming that had to occur to the tiles to make them fit the building.

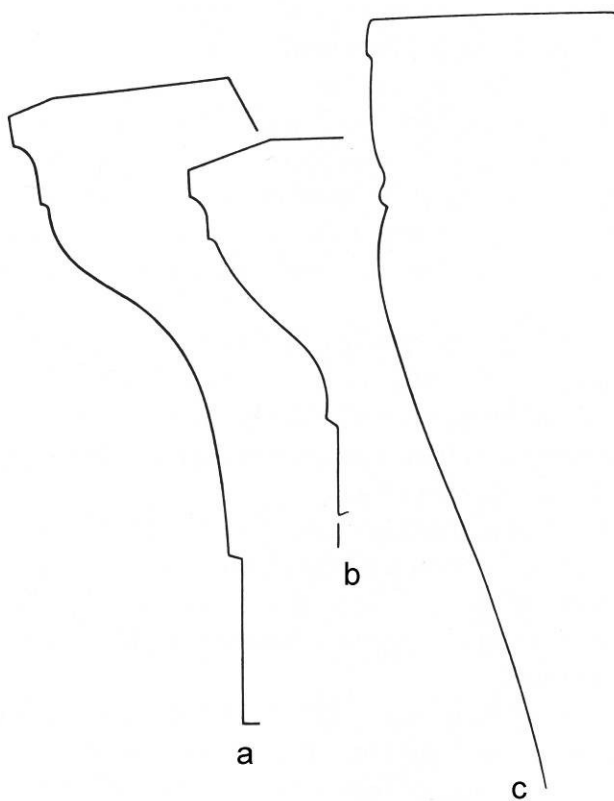

Fig. 137. Raking simas, Corinth:a) South Stoa; b) Asklepieion; c) area of Temple Hill.

Chapter 14

Polychromy

In addition to stucco applied to the columns, capitals, entablature and possibly some parts of the walls of the building surfaces, some of the architectural members were painted in accordance with normal Greek practice.²⁸⁷ Broneer noted that traces of color exist on some of the extant remains of the South Stoa.²⁸⁸ Those colors that are preserved show that the building was decorated with conventional painted designs of the Doric and Ionic orders. On the taenia of the architrave, Broneer noted red paint over stucco.²⁸⁹ He also notes that the projecting hawkbeak molding of the geison is decorated with a Doric tongue pattern over stucco.²⁹⁰ The astragal at the base of the Ionic capitals was decorated with chevrons in red and white.²⁹¹

The sima and antefixes are painted with black background and reserved decoration with added red and purple. For the lion head water spouts of the sima, the eyelashes and irises of the eyes, the nose and outer edges of the lips were painted black, the mouth and tongue were painted red and the mane, light brown. Whiskers received black dots.²⁹² **Fig. 138**

²⁸⁷ No recent full scale study of polychromy in ancient Greek architecture exists. See Billot 1982 for research into this topic made in the 18th and 19th centuries by architects of the Beaux-Arts school; Fenger 1886 on Doric polychromy; Solon 1924. See Pfaff 2003, 185-189 for a good discussion of polychromy in the Classical temple of Hera at the Argive Heraion and of the Classical period in general.

²⁸⁸ I have not yet been able to verify if the color still exists on these fragments. If it does still exist, it might be possible to clarify the colors used in cases where Broneer does not specify color.

²⁸⁹ Broneer 1954, 34.

²⁹⁰ Broneer 1954, 38 and visible in plate 9₈.

²⁹¹ Broneer *ibid.* 38 and plate 9₈.

²⁹² For the sima decoration see also Broneer 1954, 84.



Fig. 138. Sima with lion head waterspout.

Chapter 15

Refinements

The South Stoa exhibits evidence of horizontal curvature along its length and sides.²⁹³ There are at least twenty-three documented cases of curvature where the evidence has been presented as conclusive.²⁹⁴ Four of these cases occur in stoas.²⁹⁵ As Haselberger has pointed out, however, the opinion that most Greek temples were constructed without curvature is probably false and the opposite, that only a few can be proven not to have curvature, is probably the case.²⁹⁶

The curvature was measured along the front foundations, side foundations and middle wall foundations. Points were taken where the top surfaces were best preserved. All of the surviving stylobate points were shot and combined with points taken on lower courses, at places where the krepidoma had been stripped away. Combining this data is only possible to do if it is assumed that all of the blocks were of the same height within a given course, which appears to be the case. Due to the weathered state of the blocks the elevation points cannot be trusted for an exact level at the extremities of the two ends on the front stylobate. Therefore the datum points

²⁹³ Measurements were taken with a Leica Total Station at several points along the front colonnade and on preserved sections of the toichobate along the front wall of the backrooms and sides of the building.

²⁹⁴ For a list of the buildings, see Haselberger 1999, 5.

²⁹⁵ Coulton 1976, 111. These are the Stoa at Brauron, the Stoa at Oropos (Coulton 1968, 156f and Fig. 6); the South Stoa at Corinth and the Northwest Stoa at Thasos (Martin 1959, 33 and Fig. 2). Vitruvius (5.9.4) says the method for horizontal curvature in stoas should be the same as that used for temples. Also, the South Stoa at the Argive Heraion (Pfaff 1999, 119-120).

²⁹⁶ Haselberger 1999, 18 and footnote 66. See Büsing (1984, 43) for the opposite claim that only a few temples likely had curvature. One of the best examples of a temple that lacks curvature is the Erechtheion, though it is an unorthodox building to begin with (see Stevens et al. 1927, 18, 218).

at the two ends are assumed to be at the same absolute level. The curve, when reconstructed, seems to bear out the fact that the levels were more or less the same at the two ends and if there really is a difference, it is not measureable. That is, any possibility of a difference in true elevation at the two ends of the building is less than can be calculated accurately given the rough state of preservation.

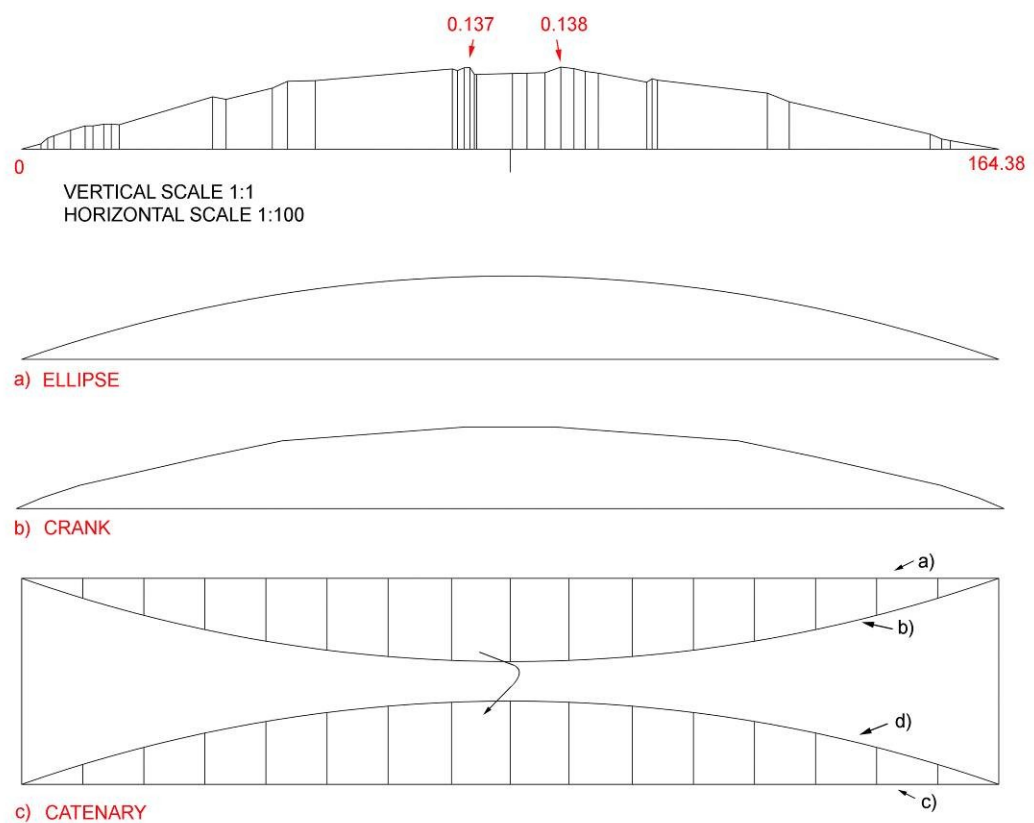

Fig. 139. Stylobate curvature as reconstructed, with three possible solutions for the curve represented. Datum point at both ends is assumed for this analysis to be at the same level.

For the front stylobate curvature, it can be observed that the middle section dips and levels off. **Fig. 139** Whether or not the dip is the result of settling or just due to preservation is not entirely clear, but the two highest

points are approximately seven to eight meters to either side of the center line and, based on the data, it does appear as though the foundations level off in the center.

The total rise of the stylobate compares well with Broneer's figure. The new data suggest that the total rise might be on the order of one centimeter less than previously thought. The main question is what kind of rise is incorporated into the front foundations? In a building with a total length of ca. 165 m. is it possible to establish a true curve, or did the builders simply slope both sides? If the curve was established in a course of the foundations, perhaps it would be possible to establish a subtle curve along the top of the course even though over such a distance and with so little change in height the difference from one block to the next would amount to between two and four millimeters.²⁹⁷ Since, however, the rise appears to be established in the ground, it would seem that a gentle slope would be all that could be done or all that would need to be done. It is also possible that two joining segmented slopes on either side of the center could accomplish much the same results.

The curvature along the north façade appears to have been established in the foundation trench itself, since there is apparently no difference in the heights of individual blocks of each course from the stylobate to the bottom of the foundations.²⁹⁸ That is, for the curve to have been introduced in one of the courses of the foundations or krepidoma instead of the foundation trench itself, the blocks should exhibit a slight increase in height along the length of the building, with a maximum difference of 0.15 m. in the middle.

²⁹⁷ See below, p. 256.

²⁹⁸ Broneer 1954, 91-93, n. 50 and plan 10; 1949, 146-147.

There have been several methods proposed for setting out horizontal curvature.²⁹⁹ It is also possible that several different methods may have been used. Even in cases where there is some direct evidence the method is still not definitely clear.³⁰⁰ One possibility is a cranked curve or polygon, where the rise would change incrementally at points along the sylobate, producing roughly a curve. **Fig. 139 b)** Over such a distance, the breaks in the curve would not be noticeable. Broneer proposed a catenary curve as the means by which the horizontal curvature was made in the South Stoa. **Fig. 139 c)** The idea of a catenary curve being created by stretching a string or chain is undermined by the distance, ca. 165 m., and the fact that the curve was created at the bottom of the foundation trench, according to Broneer, not the first course of foundation blocks. To establish the curve at the bottom of the trench, the workmen would have had to excavate the trench, level it horizontal, and then fill it back in to the inverse of the catenary curve, or alternatively measure from the top of the trench down as they went along.³⁰¹ More importantly, the cable tension required to form a catenary curve with a sag of 0.15 m. at a length of 165 m. is beyond the limits of any modern hemp cord and, one would presume, any ancient cord. With a maximum tension of 2500 N (250 kg) a modern cord of hemp 3/16" in diameter stretched over 165 m. will sag 0.29 m. If the tension is any greater the cord will snap. That is,

²⁹⁹ See especially Haselberger 1999.

³⁰⁰ Haselberger and Seybold 1991, 165ff.

³⁰¹ Coulton (1999, p. 70) dismisses the catenary method in the case of the South Stoa at Corinth, stating "it could hardly have been used in the South Stoa at Corinth where the curvature was established at the bottom of the foundation trench." A catenary curve, by definition, sags in the middle and the inverse establishes the curve. Even if possible, this method would have been much more time consuming than establishing the curve at a reduced scale with a circle, ellipse or catenary curve and then transferring it manually by means of small blocks (if these are the scamilli impares), or some such means, to the site. Once stretched to a length of 165 m. there is virtually no difference between an arc, circle or ellipse.

under maximum tension, the sag would be nearly twice as much as the total height of the curve in the South Stoa.³⁰²

An alternative idea would be that the catenary curve could have been made at a reduced scale and then transferred to the site by some means. At a reduced scale, a curve, which is in fact an ellipse, can be deduced easily from a circle or arc drawn at any scale and then transferred to the site as well.³⁰³ Although a catenary curve is not exactly the same as an ellipse, in the South Stoa the difference is impossible to distinguish given the preservation where the points on the line could be taken combined with the subtleness of the curve itself, in any case. Any of these methods could have been used for the South Stoa and given the state of the foundations and the shallowness of the curve, there is no way to know for certain.³⁰⁴

The most straightforward procedure for setting out horizontal curvature would be by means of a parabolic curve. This method was proposed by Penrose and reiterated in more detail by Stevens for setting out the horizontal curvature in the Parthenon.³⁰⁵ **Fig. 140**

³⁰² I thank Richard Anderson, Architect of the Agora Excavations, for consultation on this problem and for helping conduct an experiment in the Stoa of Attalos at Athens to test the hypothesis. The maximum length for a catenary curve with a sag of 0.15 m. is 118 m., using a standard hemp cord of 3/16" with a maximum applied force of 250 kg. Provided 250 kg of force could be applied to the cord, a catenary curve could theoretically be achieved for any building with a length of 118 m. or less. Any length over 118 m. and the cord would snap before reaching the required tension.

³⁰³ This would be similar to the method used in the Didyma drawing for constructing column entasis (Haselberger 1983, 91-123).

³⁰⁴ See Seybold in Haselberger (1999, 105-112) on the mathematical basis in general.

³⁰⁵ I thank Paul Richens for drawing my attention to this problem and discussing the validity of this procedure. See also Stevens 1934, 533-542; although Stevens' procedure is unnecessarily complicated.

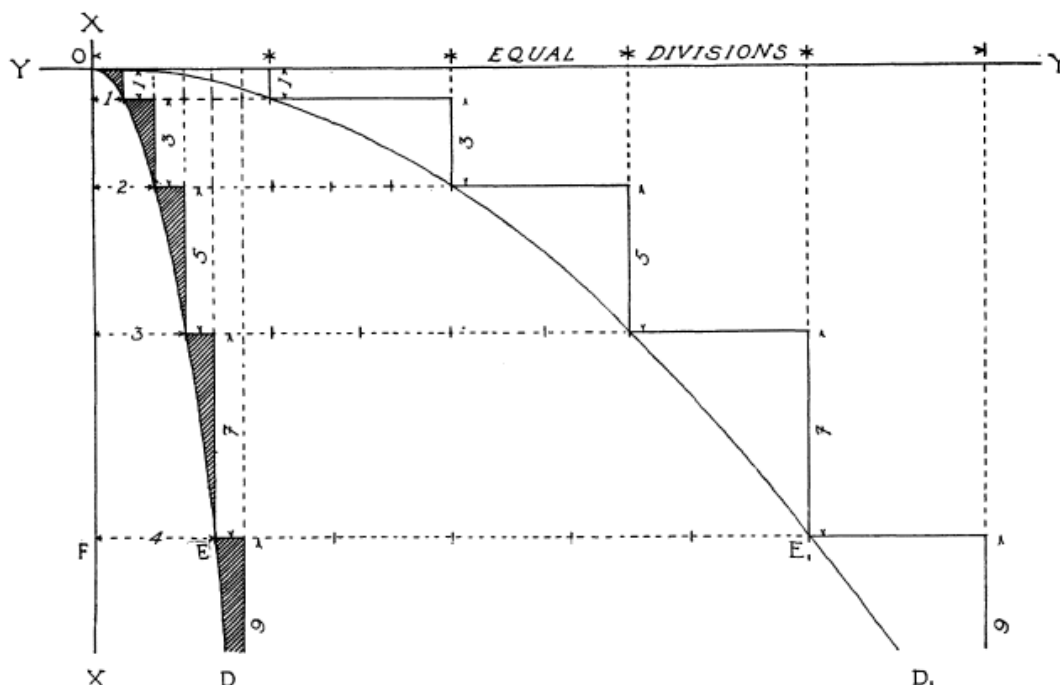

Fig. 140. Illustration of Parabolic curve established with horizontal coordinates multiplied. (Stevens 1934, 537, Fig. 4).

The means by which the curve was transferred to the building is more difficult to establish since the situation here is unlike the normal procedure of introducing the curve in a course of the foundations, where block heights could easily be checked, and not directly into the ground as is presumed for the South Stoa. The simplest procedure for establishing a horizontal ground level would be achieved by digging a trench and filling it with water. After that a parabolic curve could be established easily by laying out tiles of incremental height along the length of the trench and filling in with earth to the level of the tiles.³⁰⁶

The total rise of the horizontal curvature is ca. 0.14 to 0.15 m. The first course of foundations is made up of headers 0.585 m. in width. Dividing 165 m. by 0.585 m., and factoring in the rise, the average horizontal inclination is

³⁰⁶ If a parabolic curve was used it explains Vitruvius' comments about *scamilli impares*, whereby *impares* would be taken to mean an odd number of little steps (tiles). See Stevens 1934, 536.

0.002 m. per block. Above this course, the stretchers, ca. 1.17 m. in length, would be inclined 0.004 m. per block. Given the roughness of the blocks and the small amount to be trimmed due to the gentleness of the curvature, it is difficult to measure an acute angle on the blocks, but one should exist at the top and side edge. It is not possible to verify the very slight acute angle that should exist between the top and sides of the foundation blocks. While these angles do not, in themselves prove curvature, they nonetheless are necessary for it.³⁰⁷

This procedure, whereby the sides of the blocks are trimmed at an angle for good contact, would seem to have been less time consuming for the masons than carving the curve into the top surface over such a distance, especially given the subtleness of the curve. If the curvature was more pronounced, it would have added to the labor and at a certain point it could be argued to be more troublesome to cut each block so that the sides had the correct angle than trimming the top surfaces

Chapter 16

³⁰⁷ Laying squared blocks on a curve produces a V-shaped gap between ends of adjacent blocks, which would be microscopic at this scale. See Coulton (in Haselberger 1999, 72 and Fig. 2.4) on this problem. Coulton points out the minimal amount to be trimmed on the South Stoa blocks. The blocks of the foundations are tightly set against each other and anathyrosis is used in all courses to the bottom (Broneer 1954, 19). The trimming, however, would still have been minimal. This amount is less than the normal amount of excess limestone that would be trimmed when making the final adjustments of the contact surfaces of a joint.

Well System

The stoa is equipped with thirty-one wells, one in each of the front rooms, except the first and thirty-second rooms. The wells are connected to a long tunnel that runs beneath the stoa and brings water from the Peirene system. **Fig. 141** The construction and function of the wells have never been fully discussed. Also problematic is the question of whether or not the wells were part of the original design of the stoa or were a later addition after the stoa had been built.³⁰⁸

The tunnel that runs beneath the stoa has been explored for a length of ca. 109 m. eastward from the west end of the stoa. This tunnel was documented by Hill during his exploration of the Peirene fountain system and most of the following relies heavily on his description.³⁰⁹ The tunnel is ca. 0.60 m. wide and 1.75 m. high. The wells in each of the rooms sit just north of the tunnel and are connected either by a wall of clay no thinner than 0.25 m. or by short branch tunnels the same dimensions as the main tunnel.

The long tunnel follows close to and just north of the line of the dividing wall between the front and back rooms of the stoa. The line of the tunnel jogs slightly between rooms XIII and XIV, indicating that the tunnel was dug from both ends with the intention that it would meet somewhere along the way. Whether or not the intention was to have the two ends of the tunnel meet halfway, a slight jog ca. 109 m. from the west end indicates where the two

³⁰⁸ Edwards (1975, 197, n.13) argued that the stoa wells must belong to the original construction of the stoa because they are centered in the rooms, a point that is in fact false, nor would that matter as the rooms could have been cited on the channel line or vice versa long before the wells were put in the rooms. See below.

³⁰⁹ For the channel see Hill 1964, 61-62. Broneer gives a brief discussion of the channel and wells (1954, 59-65 plan IX).

ends met. The placement of the tunnel in relation to the walls appears to have been well thought out, as it does not run directly beneath any of the heavier load bearing walls, where it could have compromised the building structurally. In the planning stages of the stoa, the lines for the walls of the back rooms would have been surveyed and the channel could have followed this line for convenience of planning. In placing the channel so that it was not directly beneath the heavy load bearing walls, stability of the foundations for the South Stoa seems to have been a consideration.³¹⁰ The wells were sunk to a depth of ca. 12 m. The main tunnel lies at a depth of ca. 11.60 m. **Fig. 142**

³¹⁰ At least in two places diagonal connecting channels and cisterns run beneath the colonnades. The channel has not been followed beyond room XII and perhaps more diagonal channels and cisterns exist there as well.

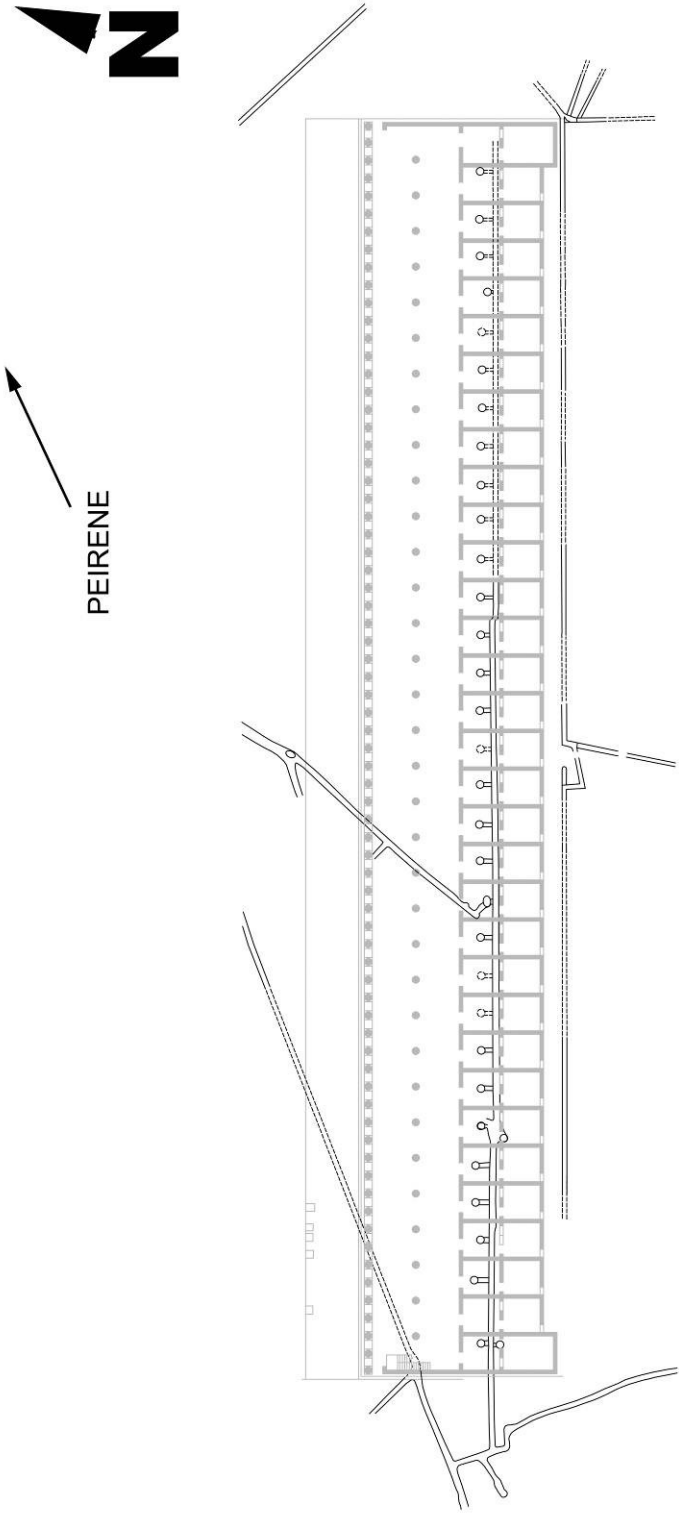

Fig. 141. Wells of the South Stoa with water channel from Peirene Fountain.

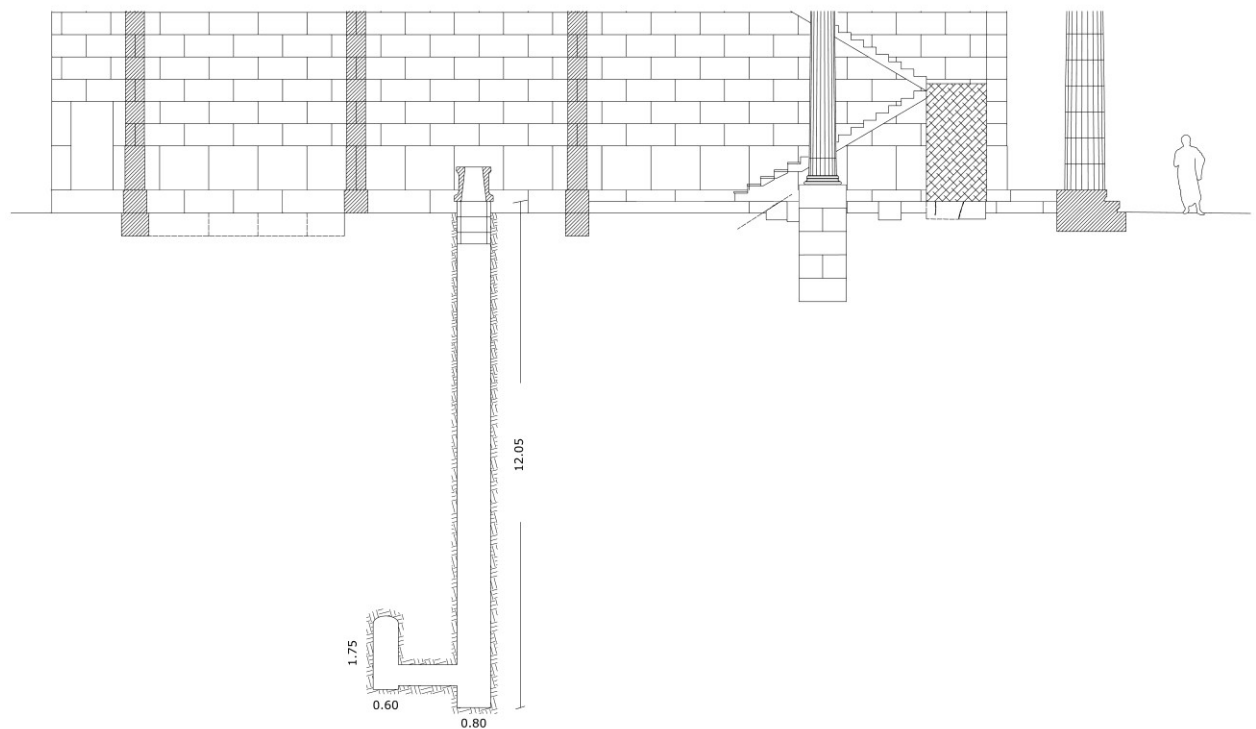

Fig. 142. Section showing Peirene tunnel and well shaft inside back room of stoa.

If the wells postdate the construction of the building then the line of sight for construction of the channel would not have been possible above ground. In order to construct the tunnel it would have been necessary to establish a line of sight below ground along the desired line, in this case the long axis of the stoa. **Fig. 143** The first two and the fifth well shafts from the west end have branch tunnels of the same diameter as the main tunnel, indicating that they were probably dug first in order to establish the line of the channel. By measuring from the wells to the cross wall above ground to the point at which the line was to be laid in front of the foundations and transferring this measurement to the cross tunnel at the desired depth, it would be possible to establish the right position of the tunnel. In addition,

further on at 41 m. from the west end of the stoa there is a manhole that runs vertically into the tunnel. This manhole also would have provided a line of sight during construction of the tunnel. The tunnel could have been started between the first two branch tunnels or from the manhole, back to the first two branch tunnels. Since the second room does not have a well, the distance between the first and second point is just under 10 m. Once this initial line was established, the line could be maintained by back sighting to the initial point. That this method was used seems certain since only three wells in the west half of the building, plus a manhole that was used as a well, have access tunnels large enough for a man to fit through. After construction these larger branch tunnels were blocked up, leaving a small opening at the bottom of the wall for water to pass through. All the other wells investigated have very small branch tunnels ca. 0.20-0.40 m. in height leading into the main tunnel. The other manhole, which was used as a well, lies 72 m. from the west end of the main tunnel.

WEST END

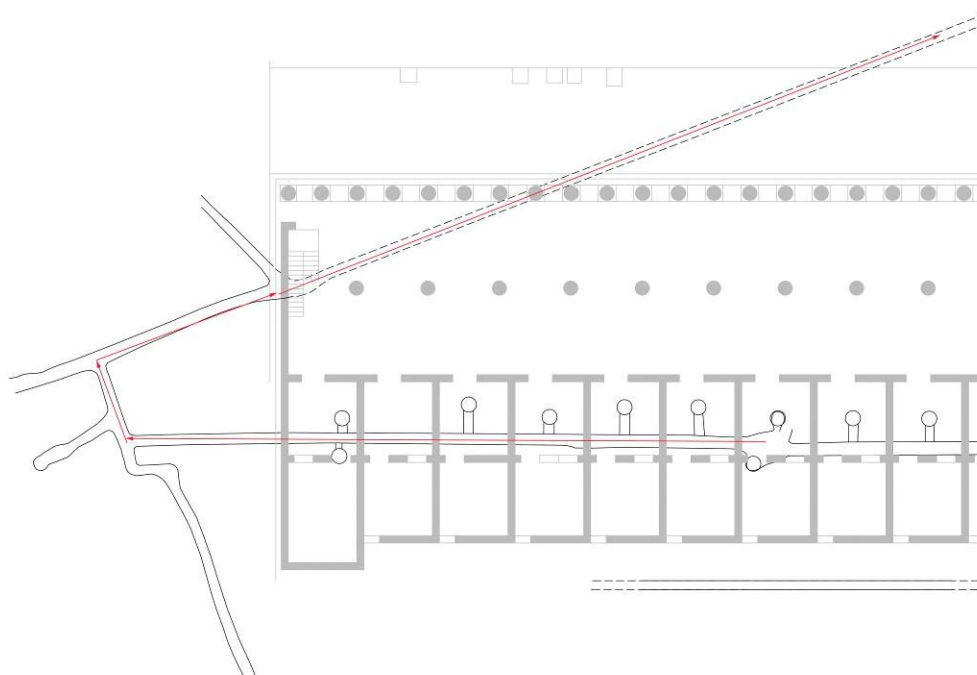

Fig. 143. West end showing underground water channel, well construction and lines of site for establishing the channel.

The wells themselves are not directly centered in the rooms and are only roughly aligned from east to west. If the wells were laid out during the initial planning of the stoa, there would seem to be no reason for them not to be in a straight line. Especially since the wells were connected to the main tunnel by branch tunnels, any deviation in the line of the main channel would not have affected the line of the wells themselves. Since the wells are not centered inside the rooms, it might be inferred that the well system was not part of the original planning of the South Stoa. There is no reason to think that, in laying out the stoa, the architect would not have centered the wells within the rooms, but we can also not assume he would have. Still, the seemingly haphazard placement of the wells is more suggestive of individual

preference than initial planning.³¹¹ It is not clear why so little attention was given to centering the wells, but it appears not to have been a functional or an aesthetic concern regarding the use of the rooms.

It has been assumed that since the axis of the main tunnel is parallel to the long axis of the South Stoa, the tunnel and stoa were planned together, but the line for the wells and channel was established from the manholes and wells themselves, which could have occurred at any time during or after the stoa's construction.³¹² Since the line of the tunnel was measured from the wall foundations inside the rooms and the wells themselves are not centered in the rooms, the more likely scenario is that the whole well system and channel were added later to the stoa after its initial construction. The following, then, is a possible timeline for the construction of the well system. Sometime after the stoa was built, it was decided that at least some rooms should have wells and that a channel should be constructed beneath the stoa to provide water. To begin with, the wells in the first and third rooms at the west end and the manhole centered above the channel were cut and the line of the channel was established. At the east end, corresponding wells and or manholes would have established the eastern line of the channel. Soon after, the other wells were dug as shop owners saw fit to undertake their construction. This scenario would imply that rooms were owned or at least managed by separate individuals, who presumably could do as they saw fit with their rooms. While this cannot be proven it is one idea that would explain the wells being off

³¹¹ It might be suggested that the wells are off center because they were dug after the rooms were constructed when a direct line of sight could not be followed, but, in that case, each well could have easily been centered in the room by measurements from the walls.

³¹² See Broneer 1954, 59 and plan IX.

center and why a few rooms did not have wells, but it does not explain why almost every owner would want, or need, a well.

It is impossible to know exactly when the wells and channel were constructed with respect to the rest of the stoa. Perhaps the wells should be connected to the construction of the latrines behind the stoa, since their construction probably heralded a new and different use of the rooms.

Part III

Chapter 17

Proportions and Metrology

In studies of Greek architecture the question of design is usually reserved for temples, as they were arguably the most important constructions in the Greek landscape requiring the highest degree of perfection. In the Archaic and Classical periods temples surely demanded the most effort, money and manpower to construct, but by the end of the Classical period, most cities began to experiment in other forms of monumental architecture, most prolifically and significantly with stoas. Beyond descriptions and theoretical reconstructions of how they looked, few studies have explored the methods by which stoas were designed.³¹³ The very nature of stoas, however, invites innovation due to the ways in which they had to conform to numerous functions and topographical considerations. The basic form of colonnade, or double colonnade, backed by a wall or rooms can be considered a standard, but the form could be stretched, or pulled horizontally or vertically as necessary and this makes their design different than temples.

The obvious point of comparison between the design of the South Stoa and temple architecture begins with the orders used. The proportions used for the South Stoa were in keeping with contemporary fashion in temple design, up to a point. Because the footprint of the South Stoa is extremely

³¹³ For exceptions, see especially Coulton 1968, 1976.

long, the overall length and width is not a factor in proportional relationships the way it is in temples. For temples, one guiding principle in the design is the footprint of the building.³¹⁴ Another way of putting it is that overall length and width would have had little or no impact on the proportions used in the South stoa. While stoas can vary dimensionally in size (length and width), the scale of the order varies less than on temples. The scale of the order, including column spacing and height, and size of the steps, had to be at a manageable, human scale. Moreover, the height of the columns affects the ceiling height, which would need to be in proportion to the overall room size in those instances when stoas had rooms.

Unit of Measurement³¹⁵

In designing the building a unit of measurement would have been employed. Before proceeding to a discussion of the possible unit or units used for the design of the South Stoa, it is necessary to briefly address the state of metrology in Greek architecture. There are a number of hypotheses proposed for the actual unit or units of measurement used by Greek architects. The

³¹⁴Coulton (1977) has set the standard by which we understand temple design based on the layout of the overall length and width of a building. But see Wilson Jones (2000a, 2001) for a different viewpoint based on the frieze unit (discussed below).

³¹⁵ The overall length measured on the stylobate/toichobate is 164.38 m. (+/- 0.01 m). This measurement was taken by the author with a Leica Total Station (laser theodolite) on several occasions in 2005, 2006 and 2007. The surveying was done using a datum point on Temple Hill as the station and back sighting to a known point at the south reservoir. This was then checked by shooting to known pins east and west on Temple hill and east of the Odeum to establish the stoa within the Greek geodetic coordinate system. The differences when compared were within a few millimeters. With a station and backsight known, the error factor is reduced to the degree of accuracy of the total station (in this case +/- 7 mm.). Other factors of error include the swaying of the prism being held on the point. Stations are checked by shooting to other known points for the purpose of eliminating human error (effectively "closing the traverse"). Broneer gives a measurement of 164.47 m. for the overall length on the toichobate (1954, 24) and stylobate (1954, 33), but see Plan Xb, where this length is given as 164.38 m.

prevailing notion is that by the Classical period architects utilized some form of standard foot length in design.³¹⁶ The field is divided into two major camps, however, when it comes to what foot lengths were used. One side argues that a few lengths were established by the Classical period and that these continued in use until the Roman foot was introduced. The other side argues that many different lengths could be used, possibly determined by regional or local measure.

For the former, Dörpfeld was the first to propose what he called the Attic Euboic Foot, which equaled 0.296 m., the same in effect as the Roman *pes*, and later a common Greek foot of 0.328 m., which he connected to the Aeginetan metric system.³¹⁷ He derived the 0.328 m. foot from the Erechtheion building accounts, which could be checked against measurements on the buildings of the Acropolis and in Attica and which also seemed to work for buildings in the Peloponnesos constructed during periods that Aeginetan currency was in use in those places.³¹⁸ This foot was later modified by Dinsmoor, who proposed on the basis of his calculations on the Acropolis and other buildings in Attica a theoretical foot of 0.32648 m., which he called the Doric foot, common in Attica and on the Greek mainland.³¹⁹ Dinsmoor also posited a shorter “Ionic” foot of 0.294 m. and a larger foot of 0.350 m., which he called a Hellenistic foot, also referred to as a Ptolemaic, Philetairic, or royal foot.³²⁰

³¹⁶Wilson Jones (2000a) summarizes the two sides of the issue.

³¹⁷ Dörpfeld (1882, 277-312) argued for a foot length of 0.2957 m., the Attic-Euboic Foot, for the buildings on the Athenian acropolis, but then changed his mind and proposed it to be the Attic-Aeginetan Foot of 0.328 m. (1890, 167-177).

³¹⁸ Dörpfeld 1890, 168-72.

³¹⁹ Dinsmoor 1961, 358-61.

³²⁰ Dinsmoor 1961, 360.

The methodology used by both Dörpfeld and Dinsmoor essentially attempted to match blocks from the Erechtheion inscriptions to specific blocks in the building, so that if the inscription mentions a block of four feet this could be checked against the measurement of that specific block in the building. This implies that the inscription refers to the building we call the Erechtheion and that the specific blocks can be identified. If both of these assumptions are satisfied, then it should be possible to say something about the foot length.

Recently, Pakkanen has argued that the inscription does refer to blocks from the Erechtheion and that when calculated the range of foot lengths produced by the measured blocks is between 0.323-0.330 m. One difficulty is that the actual lengths of the blocks do not return the same metric length when divided into their ancient equivalents, but the differences amount to less than a centimeter in each case.³²¹ This discrepancy could be due to trimming or differences between contractors lengths, which might be rough, and actual lengths called for by the architect, or simply due to errors.

Regardless of the lack of correspondence, it would seem that the safest conclusion is that the highest value returned from an actual measurement compared with lengths described in the inscription provides the best working foot length as far as can be determined. In Pakkanen's Table I, 0.328 m. is the highest value and therefore the most likely candidate for the actual ancient foot length, barring any higher values that might be found.³²²

³²¹ See Table I in Pakkanen 2006.

³²² I see no reason to prescribe a range that includes lower or higher values not actually seen in the building in an attempt at statistically valid argumentation, as Pakkanen does. Pakkanen's proposal for a way to produce likely outcomes based on sophisticated statistical methods runs the risk of introducing false values, and seems to imply that objective results can be obtained from severely biased data.

No block should produce values higher than the foot length value, since stone can only be trimmed from a block, not added.

A Doric foot between 0.326-0.328 m. has now been put forward for the metrological relief from Salamis and the builder's rule from a Greek shipwreck off the coast of Israel.³²³ Both of these metrological devices also point to other foot lengths, already proposed by Dinsmoor and others. The relief also provides measures for a 'Common' foot of 0.306-0.308 m., an Attic foot of 0.294-0.296 m. and a Samian cubit of ca. 0.523 m. (equal to the Egyptian royal cubit). The builder's rule from Israel provides a 'Pheidonian' foot of 0.333 m., a Doric foot of 0.3275 m. (attributed to Solon by Stieglitz) and an 'Archaic' foot of 0.2775 m. Thus, based on these two pieces of evidence there were a few different foot lengths possibly in use by the end of the Classical Period.

The Salamis relief and the builder's rule, however, are not without problems when it comes to pinpointing precisely what the ancient measures were. For the Salamis relief, there is a discrepancy about where the measurements should be taken. Wilson Jones' argument that measurements must have been taken on the surface as opposed to inside the relief cutting is reasoned but not absolutely certain, since a caliper could have been used to take measurements inside the cutting with relative ease and arguably greater precision, given that the surface of the stone would more likely be compromised by chips and abrasions. Against this possibility is the fact that the bottom interior cutting is not absolutely consistent, but actually rougher and less reliable than the upper surface cutting. Dekoulakou-Sideris' measurements are taken at the bottom edge of the relief cuttings, at the

³²³ For the Salamis relief, see Wilson Jones 2000a. For the builder's rule, see Stieglitz 2006.

beveled edges, and measurements here produce slightly different lengths.³²⁴

For the builder's rule, Stieglitz does not address possible problems of deformation with the wooden ruler and square, which had been submerged in the sea for a long period of time, or how this was accounted for in conservation of the wood, if at all.

A second methodology employed for ascertaining the foot unit, when inscriptional or metrological evidence is lacking, is based on examination of individual monuments, whereby measurements are derived and the foot unit calculated on the assumption that lengths should produce whole numbers, or simple fractions of a foot length. This premise itself is problematic since the assumption that round numbers, whole numbers or simple fractions will be found in actual measurements is undermined by the evidence. As discussed above for the Erechtheion, simple units may be called for at the quarry or onsite by contractors, but final dressing, trimming and other vagaries might affect the final length, causing variation which would obscure the actual foot length.³²⁵

A third method seeks to find the foot unit used for the ancient Greek stadia length. Broneer has proposed two foot units for ancient stadium lengths in the Peloponnesos, derived from his calculations at Isthmia and Epidauros.³²⁶ Broneer calls one foot unit the Peloponnesian Foot of 0.3204 m., and he calls the second one the Hellenistic Foot of 0.302 m, which, he

³²⁴ The measurement taken at the bottom of the relief cutting of the ruler is 0.322 m (Dekoulakou-Sideris 1990).

³²⁵ Stevens (1927, 222) observes that since blocks which are described as being four feet in the inscription vary on the building between 1.29-1.31 m., "blocks were (probably) first cut to the standard length and then reduced in the final dressing." This variation may be less likely for elements such as triglyphs, but even here the adjacent blocks can be adjusted to compensate for deviation.

³²⁶ Broneer 1971, Appendix I, 174-181.

reasons, replaced the first foot.³²⁷ Broneer's calculations were made on the basis that a stadion, by definition, is 600 feet. This in itself is an assumption which cannot be backed up with certainty, although it is often taken for granted.³²⁸ Another problem, which Broneer acknowledges, is that no two stadia share the same length, except at Epidauros and Isthmia, where approximately the same length is found and, Broneer argues, the same foot unit. In addition, only a few stadiums preserve their full length; so calculations of their foot unit are difficult.

Romano followed Broneer in attempting to determine the foot unit used at a number of sites in the Peloponnesos based on evidence preserved from stadia.³²⁹ His conclusions show the problems of this method, in that every city would have employed a different unit, which again is possible but not provable.

What is clear from the above discussion is that no general consensus exists among scholars regarding what units were in use prior to the Roman period or how they might be determined. The presumption that only a few different units were current during a given period is also not proven, however, there does seem to be a prevalence of only a few foot units in use. This does not exclude local units, or slight variations on a few units also being used to a lesser degree.

What follows is an attempt to examine the evidence from the South Stoa at Corinth with a view to determining the foot unit. Each method

³²⁷ Broneer, *ibid.* 177.

³²⁸ See Wilson Jones 2000a, 74.

³²⁹ Romano 1981.

advanced previously is applied to the South Stoa and the resulting outcomes are tabulated.

By examining individual block lengths and key dimensions it is possible to arrive at a unit which may be the original unit of measurement used in the construction of the South Stoa. Dimensions of certain blocks and the interaxial distances between the columns strongly suggest that a standard unit was employed. Arguably, two of the most important criteria for establishing the ancient unit are standard lengths of the krepidoma blocks and the interaxial spacing of the columns of the front colonnade.³³⁰ **Fig. 144** For the foundations and krepidoma, the block lengths are ca. 1.17 m. and several measure exactly this distance. This length also applies to the orthostates of the sides of the building. The normal interaxial spacing of columns, transferred also to the architrave block lengths, is 2.34 m. (2 X 1.17 m).

³³⁰ On the importance of the interaxial measurement as a fundamental element in design, see Coulton 1974, 74-77; Bankel 1983, 93; de Waele 1980, 240; de Waele 1990, 1, 4, 19, 63; Pfaff 2003, 347. The krepidoma blocks of the South Stoa are ideal candidates for length measurements because in many cases along the north colonnade the blocks are well preserved and still tightly fitted against one another, plus they are spaced in relation to the other components of the Doric façade.

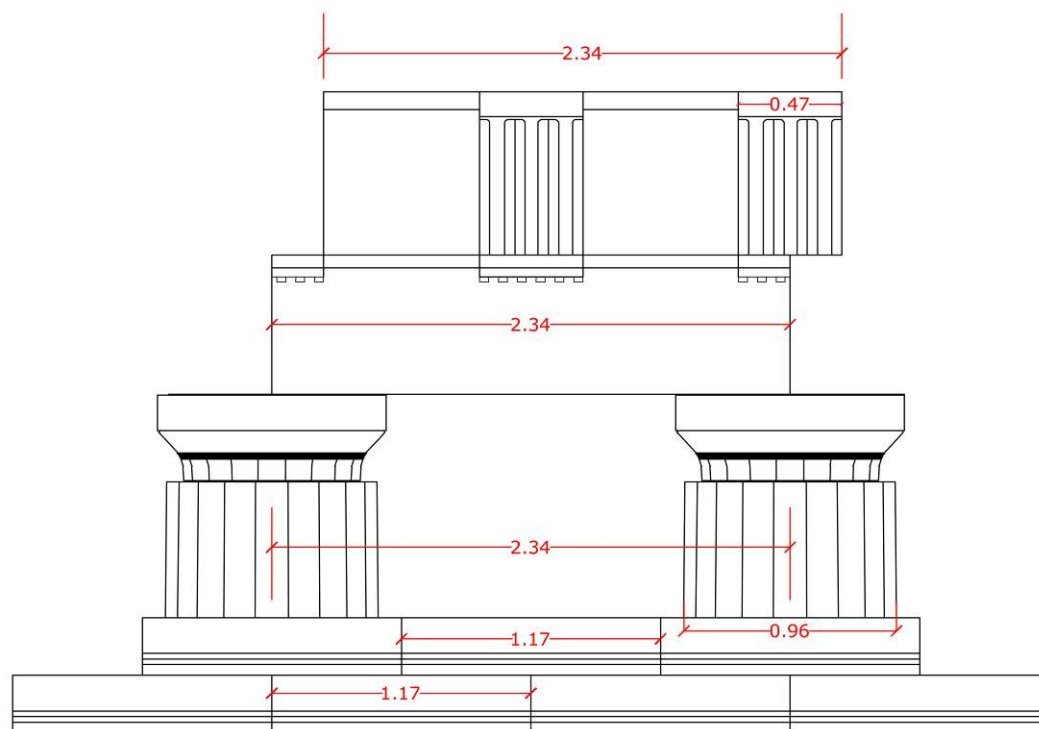

Fig. 144. Principal dimensions of the Doric Order of the façade.

The proportions and dimensions of the South Stoa have previously received only cursory treatment.³³¹ In laying out the footprint of the building an earlier hero shrine (a stele shrine) was partially demolished to make way for the west end of the building, while the remaining half of the shrine continued in use well into the Hellenistic period after the construction of the stoa. This would seem to imply that the length of the building was not subject to the pre-existing topography of the site, but was imposed on it, suggesting that the overall length was determined by either a convenient module for the interaxial

³³¹ On the unit of measurement used in the building, Broneer (1954, 25) followed Heermance who, in 1904, said that a Doric Foot of 0.328 m. does *not* work for the axial distances of the colonnade and that the building's overall measurements must have been determined by the site rather than by a particular unit. Heermance 1904, 437. Using a Doric foot of 0.328 m., the axial distance of 2.34 m would be 7.13 D. F. Other measurements also return numbers that would be difficult to work with; for instance the overall length of the frieze, 164.25 m would be 500.762 D.F. But see Heermance 1905, 181, where he adds a correction that a probable foot of 0.292 m. was used in the South Stoa (not cited by Broneer).

distance of the colonnade, an overall round measurement, or a combination of both.

Romano, in his dissertation on Peloponnesian stadia, argues that the overall length of the South Stoa was nearly the same length as the dromos, or race course, which runs directly in front of the stoa along a slightly different orientation.³³² He hypothesized that the stoa was constructed to have an interior length equal to 600 feet (a stadion), but does not state the precise limits involved. Romano's hypothetical Corinthian foot of 0.269 multiplied by 600 gives a distance of 161.46, his proposed length in meters for the dromos at Corinth. The normal interaxial distance is 2.34 m. The Doric colonnade minus the two end columns is $69 \times 2.34 = 161.46$ m. In actual fact the overall length of the stoa as measured is 164.38 m. and this distance would require the interaxial distance to shrink a few millimeters, which would have a large effect over the full length ($2.3378 \times 69 = 161.3082$). The length of the stoa requires 70 bays for the colonnade. On the stylobate level the distance of 161.46 m. falls between the last two bays if centered on the overall length.

Fig. 145 It would seem that Romano's proposed length for the Corinthian stadion is based on a hypothetical unit (interaxial distance of 2.34), which if carried out for the full length of the stoa, would produce a length 10 cm. longer than what was actually built. If Romano's Corinthian foot is correct, then the stoa might have been designed with the stadion length in mind, however, the stadion length is, itself, hypothetical and in actual practice, the theoretical unit

³³² Romano 1981, 165-166.

is slightly less than what Romano used in his calculations for an overall length.³³³

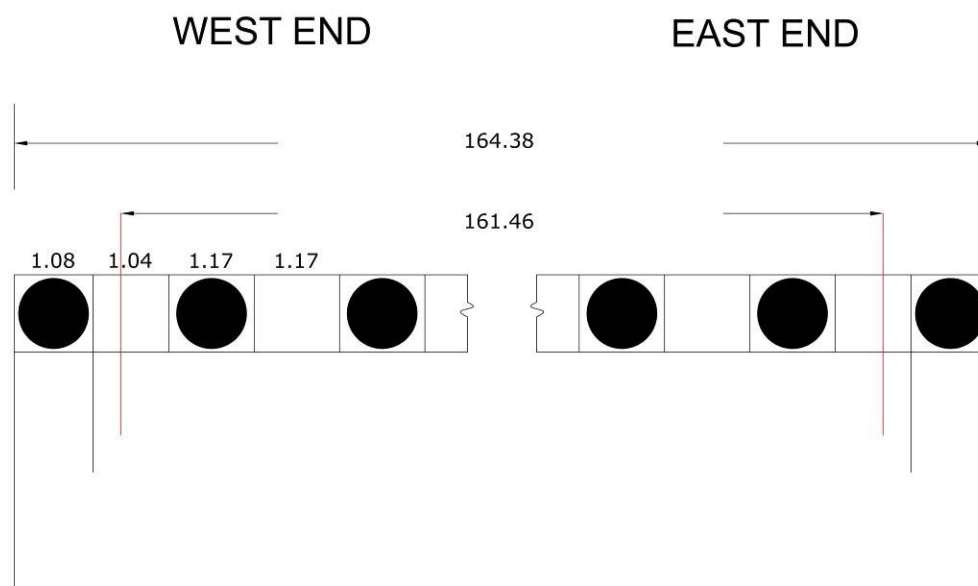

Fig. 145. Romano's stadion length applied to the colonnade of the South Stoa.

Romano's proposed Corinthian foot of 0.269 m., however, does not seem to work as a unit of measurement for any of the internal dimensions of the stoa, such as convenient units for the frieze blocks and interaxial distance of 2.34 m., or for other crucial measurements such as the standardized block

³³³ Without confirmation by means of measurement for the exact length of the stadion at Corinth, it is impossible to say for certain whether or not the South stoa derived its internal length from the stadion. As it stands, Romano's argument for the length of the stadion at Corinth apparently depends on the stoa length. On the date of the racecourse Williams (1970, 5-6) places it in the third to fourth quarter of the 4th century B.C. based on pottery under the fill of the dromos. Williams also ties the construction of the course and stoa together as one major project (*ibid.*). A Hellenistic reservoir, directly in line with a water channel with six settling basins running along the south side of the dromos, is 173.45 m. west of the starting line. This reservoir is also at the right elevation for the western end of the dromos. According to Williams (1970, 3-4) "the western end of the course may not have been far from this reservoir." The distance of the reservoir from the starting line, when divided by the possible ancient foot used in the South Stoa, is almost 600 F ($173.45 / 0.2925 = 592.99$). For the Hellenistic reservoir, see also Stillwell 1936, 43.

lengths (1.17 m.) employed in the building.³³⁴ A length of 2.34 m divided by an ancient foot of 0.269 m returns a value of 8.7 ancient feet, for instance.

The stadion length and the length of the stoa may have some connection, but, for the construction of the building, a different unit appears to have been used, which I would suggest was a unit based on, or close to a foot length of 0.294 m. the standard Attic-Ionic foot, also sometimes referred to as the Ionic foot. Using a theoretical foot of 0.2925 m., normal block lengths of 1.17 m. are 4 feet, the interaxial distance of 2.34 m. is 8 feet and so on. Therefore, a theoretical foot length for the construction of the stoa could be 0.2925 m. A foot of ca. 0.294 m. and a Doric foot of ca. 0.326 m. were both apparently in use in the Peloponnesos in the 4th and early 3rd centuries B.C. The use of a measure close to 0.294 m. has been proposed for several buildings at Epidauros, which are roughly contemporary with the South Stoa at Corinth, while at Nemea a measure close to the Doric foot of 0.326 has been proposed for the Temple of Zeus.³³⁵

If an ancient foot unit of 0.2925 m. is applied to the columns it is possible to arrive at a more precise theoretical column height than is provided by statistical calculation alone. As discussed above, an average drum height can be calculated to be 0.62 m., and 9×0.62 equals 5.58 m., plus a capital height of 0.395 m. equals ca. 6 m.³³⁶ If the number of drums is increased to ten ($10 \times 0.62 = 6.20$ m.), the total height exceeds 6.50 m. with the addition of

³³⁴ Convenient units would be even multiples of a unit.

³³⁵ A foot unit of 0.30 has been proposed for several building projects at Epidauros ranging in date from the 4th century to the 3rd century B.C. (see Burford 1969, 70). The theoretical unit for the Temple of Zeus at Nemea is 0.32565 m. (Hill and Williams 1966, 9, 45); on variation of foot units as a sign of conventions of different stone masons rather than different architects (ibid. 45).

³³⁶ As already discussed above regarding the shafts and column height, the column certainly cannot be shorter than Broneer's proposed column of 5.70 m. and the columns should be in the range of ca. 6-6.5 m. in height.

a capital. Working from a theoretical foot unit of 0.2925 m. it is possible to establish a column height that falls within the range of averages provided by the drums that also is a sensible number of ancient feet with which to work. If the columns were meant to be 20 ½ feet of 0.2925 m. it would make the column height without a capital 5.99 m. With the addition of the recorded capital height of 0.395 m., the full height of the column would be 6.385 m. A capital height of 0.395 m., which in ancient feet comes out to 1.3504, would be more workable at 0.402 m, with the equivalent in ancient feet being 1.375 feet or 1 foot and 6 dactyls (3/8 of a Foot) making the total column height with capital ca. 6.39 m. or 6.65 times the lower diameter.³³⁷

It is highly likely that even if a standardized foot unit was used, the actual length would depend on several variables having to do with how the unit was transferred and how the blocks were cut and trimmed. If the unit was transferred by way of a stone carving, like the Salamis relief, variation could be minimal to perhaps within a millimeter or less, but if the dimension was transferred to a wooden or metal rod, the variation would increase. This would explain how variations of a particular unit involving millimeters could exist between buildings as well as within a single building.³³⁸ If the variation is more

³³⁷The columns of the Temple of Zeus at Nemea, dated ca. 330-320 B.C. are 6.3421 times the lower diameter (Hill and Williams 1966, 44). The columns of the temple at Tegea are 6.169 times the lower diameter (Dugas, Berchmans, and Clemensen 1924, Pls. IX-XI), but see Pakannen (1998, 23): lower drum diam. preferred = 1.55 m. (ibid. 62) column height with capital = 9.544-9.580 m. The ratio would be 6.157-6.18. The temple of Artemis at Epidauros, dated 300-270 B.C., has Doric columns 6.8-7 times the lower diameter (Roux 1961, 208; for date ibid., 221-2). Tholos at Delphi, ca. 370, 1:6.82 (Roux, 1961, 140). The Tholos at Epidauros, ca. 340?, 1:6.92 (Roux, 1961, 140). Stoa at the Amphiaraion, Oropos, mid 4th century., 1:6.9 (Coulton 1968, 157). (4.63/0.626 [0.656 arrises])=7.06.

³³⁸ On the Athenian acropolis, for instance, Dinsmoor posits four slightly different theoretical foot lengths for four buildings of the Periklean period (Parthenon, 0.327685 m; Propylaia, 0.32723 m; Athena Nike temple 0.32614 m; Erechtheion,

than that, it might suggest an entirely different unit was used.³³⁹ Alternatively, there is the argument that rather than a few “universal” foot measurements, a variety of regional foot lengths could have been employed or even several different units used in one building. The contractors and stone masons working in the quarry would have had at least a rough idea of the size of blocks needed. In all cases they must have produced blocks with enough room for trimming, final dressing and polishing, with the final measurements taking place during the trimming process on site as the blocks were set.

In the South Stoa, it is possible that one unit was used for the construction of the front of the building, including the colonnade spacing and the frieze units, and another unit was possibly used for the back half of the building. Some elements, like wall blocks, follow the front modular system in length, while they seem to diverge in height, which may be due to trimming for curvature.

Another way of approaching the problem is by examining the possibility of a modular unit for the design of the building. If this unit can be determined it provides a means of working backwards to the actual foot unit or at least corroborating the theoretical unit.³⁴⁰

0.326 m). See Dinsmoor 2000, 447-449. For the Erechtheion, see Dinsmoor 1950, 195 n. 1; Dinsmoor 1961, I, 358-359.

³³⁹ The subject of standard measures in Greek architecture has proven to be notoriously problematic. See especially the introductory remarks in Wilson Jones (2000, 73-77). Scholarship is further complicated by inconsistencies in nomenclature referring to the various foot units themselves. Thus, the Doric foot is sometimes referred to as the Attic foot, and is usually given as 0.326-0.328 m., or 0.308 m., with variations cited in individual buildings. Dinsmoor, as early as 1910, sometimes used the term “Attic” for the Doric foot of 0.327 m. The Ionic foot, usually cited as 0.294 m.; is sometimes called the Attic-Ionic foot.

³⁴⁰ See discussion of modular units below. Vitruvius lays out the modular system of design for Doric Temples (Bk. IV 3.3-10). To illustrate the problem of determining the design module (ἔμβάτης), one has only to witness the different modules proposed for the Parthenon and Athenian Propylaea (Bankel 1983, 82-83; Hoepfner 1984, 22, n. b;

Design considerations

There is no description or building account for the South Stoa, but the procedure can be postulated none the less, based on analogy with known descriptions, comparison with other buildings and autopsy of the South Stoa. The Arsenal inscription provides good evidence for the procedures followed by the contractors.³⁴¹ The general specifications laid out by the contractor or architect indicate the importance of certain dimensions and considerations over others. For the South Stoa, block lengths are coordinated with inter-columnar measurements, architrave and frieze lengths, indicating these must have been specified beforehand in simple dimensions. In this case the dimension of ca. 2.34 m. for interaxial distances and architrave and frieze lengths, and half this length, 1.17 m. for block lengths establishes a simple procedure for cutting and setting blocks so that the façade dimensions would work in length and elevation. It is more difficult to determine whether or not the design proceeded from overall length and was divided into the smaller parts, such as interaxial distances and block lengths, or it was the smaller units that were established first. In any case, if a foot length of 0.2925 m. is used, the specifications would indicate four feet for block lengths and 8 feet for interaxial distances, frieze blocks and architraves. It should be noted that

de Waele 1990, 3-4). For the fact that modules have been proposed which do not coincide with a standard foot measurement, see Koenigs 1979, 217-234; de Waele 1980; Cooper 1996, 130-31. A module falling within the range of a Doric foot of 0.326 (0.3252 m. theoretical) has been proposed for the Temple of Hera at the Argive Heraion (Pfaff 2003, 347).

³⁴¹ Lorenzen 1964.

0.2925 m. does divide evenly into the overall length on the stylobate of 164.385 m. (562 F).

In the specifications of the Arsenal inscription, the diameter of columns as well as height of columns and wall height are given.³⁴² The lower column diameter of the South Stoa is ca. 0.96 m. on the arrises, which should probably be roughly $3\frac{1}{4}$ ancient feet of 0.2925 m. The column height, made difficult because of the lack of data, has been hypothesized to be 6.30-6.50 m. A theoretical height of 22 ancient feet of 0.2925 m. would produce a column 6.435 m. in height. In many cases metric dimensions translated to theoretical ancient feet do not work out to be simple round numbers.³⁴³

Modular Proportions

For Doric design, Vitruvius calls for a module to be used based on one half of the column diameter.³⁴⁴ It is assumed that Vitruvius' discussion reflects earlier Greek precedents, at least as far back as the Hellenistic period. These traditions probably reflect the perfecting of earlier Greek temple design of the 5th century B.C.³⁴⁵ It has also been shown that this module directly relates to the triglyph width in most if not all cases where a module can be shown to work. None the less it is presumed that Vitruvius' discussion concerns the lower column diameter of the exterior colonnade of a building. It has been noted that in Vitruvius' scheme the module also equates to the triglyph width,

³⁴² Lorenzen, 1964.

³⁴³ Dinsmoor Sr.'s units of measure in the Athenian Propylaia are an example where sometimes convoluted argumentation is necessary to explain why ancient foot measurements are not simple multiples or fractions of feet (2004, 5-7).

³⁴⁴ Vitruvius, 4.3.3-4. The diameter of the columns is equal to two modules; hence one module equals the radius.

³⁴⁵ Vitruvius cites Hermogenes in particular regarding modular design in the Ionic order (4.3.1) and makes reference to his teachers (4.3.3), which may also be taken to be earlier Hellenistic treatises.

giving rise to the idea that this dimension may have been the most critical of the two in Greek practice. In fact, the triglyph width, or its nominal ideal in a convenient value of dactyls or feet, seems to resonate in many cases where a module can be shown to work.³⁴⁶

The lowest column drum is preserved *in situ* at the west end of the South Stoa, so we can ascertain this dimension with certainty. The lower column diameter is 0.90 m. inside the flutes and ca. 0.96 m. on arrises. The measurement inside the flutes can be considered to be a fairly accurate measurement of the original interior surface diameter. Whereas weathering and other damage have affected all of the arrises, the inside of the flutes retain close to the original surface. While the interior flute measurement of 0.90 m. is exactly twice the corner triglyph width (if taken as 0.45), it is, in any case, the dimension from the arrises that should matter. The reconstructed diameter of the column on the arrises (0.96) is over twice the normal width of the reconstructed triglyphs ($0.468 \times 2 = 0.936$). The lower column diameter, therefore, would not seem very helpful as a module.³⁴⁷

For temples in particular, a convenient formula exists for axial bays of five times the triglyph width (Ax. Bay = 5T).³⁴⁸ If applied to the South Stoa, the formula works perfectly ($2.34 = 5 \times 0.468$). Therefore, the triglyph width does make a convenient module for the layout of at least the front colonnade of the South Stoa.

³⁴⁶ Wilson Jones 2001.

³⁴⁷ That the corner columns were not thicker than the others is shown by the fact that beside the two lowest drums in situ on the west end a drum was found which is of the same dimensions as the second drum on the corner. The drum cannot have been a bottom drum because it has an empolion in the bottom, and therefore it must have been above a lowest drum of the same dimensions as the lowest drum at the corner (see Broneer 1954, 31-32).

³⁴⁸ See Wilson Jones, *ibid.*

The layout of stoas on such a grand scale as the South Stoa at Corinth would seemingly have demanded a higher degree of regularity to facilitate construction, as opposed to temples which might incorporate fluctuations in intercolumniations and metope widths, for example.³⁴⁹ Modular design in the South Stoa can be divided between the front half and the back half of the building, so that the colonnades and exterior walls along the two sides follow one scheme and the backrooms follow a separate scheme.

The proportions of the building are perhaps tied to a module, but it would seem likely that it is calculated in relation to the interior elevation and length of the building. In the South Stoa the large exterior order is based on a modular system which may be related to the frieze units. Since the order is relatively large, a two metope system is retained, even though many stoas were beginning to adopt a three metope system by this time.³⁵⁰ The larger order was adopted for the South Stoa presumably to allow greater height in the interior for two levels, while maintaining the stability of the outer colonnade. It would also have had an aesthetic appeal given the length of the building. If the order had been smaller, or more slender, it would have had a low profile in relation to its length. It is only with long stoas that the size of the order begins to be such an issue, since height to length can no longer be proportioned the way it can with temples, where the front and flank lengths are integrated with the height more easily. The overriding factor for height,

³⁴⁹ As is seen in the Parthenon. These differences are subtle but would have required more time and effort to produce and fit into the overall scheme.

³⁵⁰ As Coulton points out, there is sufficient space between columns in such a large order, so the retention of a two metope system makes sense in the case of the South Stoa at Corinth (1976, 116).

however, and by default, the proportions of the order, would have been the desired height for the interior space.

For the interior colonnade, a reason to strengthen the columns came from the fact that the interior colonnade carried a balcony, which included piers and a parapet. While not carrying the load of the ridge beam, the load of the balcony would still have been of concern. Slender columns spaced so far apart and carrying such a load would have given an unsettling appearance.

In temple design, where both Doric and Ionic columns are used, none of the above issues prevail. When Ionic is used, it is almost never directly juxtaposed with Doric and the interior columns do not carry more than ceiling beams and coffers. Ionic buildings, on the other hand, tend to have more slender proportions even though the columns may carry the full weight of the roof load. Obviously the designers had to consider the weight ratio, but in any case the relatively slender column proportions could be accommodated in temples, since the inter-axial spacing would be much closer in comparison to interior column spacing in stoas.

Frieze and Intercolumniation

As noted above in the section on the Doric frieze, there is variation in the mutule width taken from the corner geison block (0.45) versus the regulae and triglyph widths taken from the frieze blocks (0.468). If a triglyph measurement of 0.468 m. is used, the South Stoa would follow Vitruvius' specifications for the relationship between triglyph and metope size within the frieze. Vitruvius calls for a 2:3 relationship. A triglyph of 0.468 and metope of 0.702 would follow this ratio and the interaxial distance of 2.34 would equal

five times the triglyph width, which is the normal method for peripteral temples.³⁵¹ The frieze ratio is slightly larger using a triglyph width of 0.45, where the metope width would have to be 0.72 ($0.45 + 0.72 = 1.17 \times 2 = 2.34$). Using a triglyph width of 0.45, the metope width would be 1.6 times the triglyph width, rather than 1.5 times as much and the intercolumniation would be 5.2 times the triglyph width. This could be understood as a result of making the columns narrower and the intercolumniation wider, which is in keeping with stoa design as a whole. In the South Stoa the amount of widening is slight, due to the fact that the two triglyph system is retained instead of the three triglyph system, but the intercolumniation would be slightly stretched nonetheless.³⁵²

If the module is based on or related to the triglyph width then one important question is whether or not the module relates to the unit of measurement used for other major elements of the building. It was proposed that a unit close to the Attic foot of 0.294 m. was utilized in construction and furthermore that the theoretical unit was 0.2925 m. A triglyph width of 0.45 m. divided by 1.5 would be 0.30 m. The difference is 0.007 m. If the presumed normal triglyph size of 0.468 m. is used the outcome is 0.312 m. A triglyph of 0.468 m. would be 1.6 times the theoretical foot of 0.2925 m.

In general practice, whether or not the module is based on the column diameter or is based on the triglyph width, is seemingly irresolvable. Possible scenarios are:

³⁵¹ See Coulton 1974b, p. 63.

³⁵² Compare the temple in the Asklepieion at Corinth (late 4th c. B.C.), where the triglyph to metope ratio is slightly less than 2:3 (metope width is less than 1.5 times triglyph width). The frieze dimensions are as follows: triglyph = 0.384 m. w., metope = 0.56 m. w. (Roebuck 1951, 32).

1. Lower radius of column based on the triglyph
2. Triglyph based on $\frac{1}{2}$ the column diameter (Vitruvius)

An essential problem of modular analysis arises from the assumption that one of these two scenarios is responsible for producing the module. What is still unknown is how that dimension would have been arrived at and whether or not a module was the determining factor in the design.³⁵³ In temple design, the platform width would provide a possible dimension into which the module could be divisible.³⁵⁴ In stoa design, the overall proportions of the individual elements might be borrowed from temple design, but for stoas other factors must be dealt with. In a stoa with a desired height of lower and upper storeys, the elevation and general size of the bay become the overriding factors as outlined above. The column proportions would then follow, and the lower column diameter would then provide the necessary module for the principal dimensions.

Column Spacing and Doric proportions

The narrow column spacing of the South Stoa, defined by having only a single triglyph between the intercolumniation, is characteristic of stoas with two storeys. **Table 3.**

³⁵³ On the problem of modular design, see Coulton 1975, 69, 98.

³⁵⁴ Coulton *ibid*, 69.

Table 3. Interaxial measurements of lower exterior stoa colonnades

Name	Interaxial distance	Date	Façade elev.
Stoa of Zeus, Athens	3.018 m.	5 th c. B.C.	Single Storey
E. Stoa, Asklepieion, Athens	2.75-2.76 m.	L. 4 th -E. 3 rd c. B.C.	Double Storied
S.Stoa, Corinth	2.34 m.	E. 3 rd c. B.C.	Single Storey
Middle Stoa, Athens	3.04 m.	3 rd c. B.C.	Single Storey
Stoa of Eumenes, Athens	2.45 m.	2 nd c. B.C.	Double Storied
Stoa of Attalos, Athens	2.42-2.43 m.	2 nd c. B.C.	Double Storied

For the South Stoa, the interaxial spacing of the lower columns is 2.34 m. Compared with other stoas known to have a two-storied façade, the South Stoa at Corinth has a relatively closer column spacing. This cannot be due to the larger order, which should make the interaxial distance greater. The reason for the larger order in the South Stoa was to create a greater height for a second interior level rather than for the purpose of accommodating an upper

storey façade.³⁵⁵ One possibility is that the closer column spacing is a conservative design feature, but it would not have been possible to stretch the interaxial distance by simply widening the metopes even slightly, since any additional spacing in the intercolumniation would have caused serious problems over the full length of the stoa. The only alternative would have been to widen the spacing to two triglyphs, as is often done in stoas. Due to the size of the order, however, this would have created an enormous space between columns.

The Design of the Backrooms

Perhaps the most peculiar feature of the South Stoa is the design of the backrooms. The rooms are divided into thirty-three units within the overall length of the building. The simplest procedure for dimensioning the rooms would have been to base the divisions on the spacing of the thirty-four interior columns, so that the dividing walls along the length of the building would follow the interaxial distances of the interior colonnade, but this did not happen.³⁵⁶ If, hypothetically, there were thirty-five rooms instead of thirty-three, with walls falling on line with the interior colonnade, the normal room size would have been 4.815 m. in width, center to center instead of 4.96 m.

$$[(164.36 - 0.63) / 33 = 4.9615]$$

$$[(164.36 - 0.63) / 34 = 4.8156]$$

³⁵⁵For comparison of Doric column proportions, see above section on Doric columns.

³⁵⁶This is almost never done in stoas with rooms. In most buildings, though, the dimensions of the rooms seem to be designed in an *ad hoc* fashion and the rooms, themselves, do not share the same overall dimensions as they do in the South Stoa at Corinth (Coulton 1976, 86-87).

The difference between the slightly shorter width for the rooms would be less than 0.15 m. in width per room if the rooms were lined up on column axis. One advantage in doing this would be that block dimensions could have followed the same modular system as the front of the building. That the backrooms do not follow the modular system of the front of the building suggests that the choice of thirty-three room units over another number was a conscious design decision, so either there was some reason that there needed to be exactly thirty-three rooms, or there was a need to have rooms not shorter than 4.96 m. in width. It must also be noted that 33 rooms would be possible if the length of the stoa was shortened, suggesting that perhaps the overall length was equally important. The fact that the doorways into the rooms are off center, would normally suggest that couches were placed around the edges of the rooms. If this was the case, then the extra 0.14 m. might be necessary for couches to fit, but, there is no satisfactory arrangement for "normal" size couches.³⁵⁷

³⁵⁷ See below; also Coulton 1976, 88.

Part IV

Chapter 18

Date and function of the South Stoa

Broneer, in his 1933 report, initially dated the South Stoa to the second half of the 3rd century B.C., but later amended this and in the final publication of the building he dated the construction in the second half of the 4th century.³⁵⁸ The initial date in the 3rd century B.C. was arrived at because fill in against the foundations of the front room III included 3rd century B.C. material, but this date was abandoned, it seems, largely because all of the moldings attributed to the building appeared to be earlier. Lucy Shoe, in her publication of Greek moldings, dated all of the Greek period moldings from the stoa in the second half of the 4th century B.C. and argued extensively that a date after the 4th century seemed very unlikely.³⁵⁹ On the other hand, Roux, following Martin, preferred a later date and settled on a period between 320 and 270 B.C.³⁶⁰

The 3rd century B.C. deposit in room III could have been a secondary fill, although Broneer did not think so at first. The fact that so much of the building underwent renovation over time, which extended into the foundations in large parts of the building, suggests that none of the original floor levels existed in the rooms. Indeed, in Broneer's later publication of the building, he

³⁵⁸Broneer 1933, 559, for the 3rd century date. This date was based on a deposit of terracotta Fig.urines, shields and coins which dates to the mid 3rd century B.C., found in front room III from east, down at the bottom of the floor fill against bedrock and against the cross wall foundations.

³⁵⁹See especially the note by Shoe (1936, 71, XXX, 28, 29). "The form of the profile and its proportions are those of a cyma used commonly in the 4th century The profiles of the other mouldings of this Stoa are also definitely 4th century in character and therefore so placed on the plates."

³⁶⁰Roux 1961, 348, n. 6 also, 414, 417, 421. Martin 1956, 213-216.

nowhere mentions good floor levels from the Greek period. In any case, it is perhaps more probable that the floor levels in the rooms were serviced from time to time and that at some point after the middle of the 3rd century a refurbishment of the floor involved the depositing of the material from cleaning up the room.

As for material remains from the excavations, only the stoa wells seemed to provide evidence of the earliest use of the building. Coins and pottery from among the material at the bottom of the Stoa wells date from the late 4th century to the early 3rd century B.C.³⁶¹ This material, however, does not provide conclusive evidence for the construction date of the stoa and its validity as a dating tool is compromised by the possibility that all of the material was dumped at one time, in which case its association with the use of the stoa is questionable at best.

A better source for a construction date exists beneath the stoa terrace. There a drain deposit, just to the north of the stoa and under the stoa terrace was found which must predate the construction of the terrace and the stoa.³⁶²

The date given to this deposit is ca. 300 B.C. The date of the drain deposit,

³⁶¹ Broneer 1954, 64 and n.30. If the fill from the bottom of the wells is "habitational debris", It could represent the earliest activity associated with the wells, but it cannot be used to date the construction of the wells or the building. The wells could have been created after the building was constructed in which case material in the wells would indicate only that the date of the construction of the stoa be sometime earlier than use fills in the wells, if that is what they are and this is not certain.

³⁶² Mcphee and Pemberton (in press). This drain deposit is designated 1971-1 in the Corinth Excavations inventory. For previous attempts to date the construction of the stoa: Williams (1980, 107) concluded that the stoa should date "later than mid 4th century, perhaps as late as the 320's B.C.", based on the destruction date of a pre-stoa reservoir south of storeroom XXI and the dates of the latest excavation deposits at the west end of the stoa; Broneer (1954, 96) dated the building to the third quarter of the 4th century B.C.; Shoe (1936, 64, 71, 113, 164) dated the moldings to the second half of the fourth century B.C. A coin stamped with Antigonas Gonatas (277-239 B.C.) found inside a crack between the toichobate course and the course below in room XXXI was recorded by Broneer (N.B. 183, 116), though, as a single piece of evidence, it cannot be used to date the construction of the stoa and could be a later intrusion.

therefore, provides a *terminus post quem* date of ca. 300-290 B.C. for the construction of the South Stoa. This drain was filled with pottery and other debris at the same time, or shortly before, the terrace was built as part of the reorganization of the area for the construction of the South Stoa. **Plate 3** The date is corroborated by other remains which partly underlie the stoa. Building I was destroyed late in the third quarter of the 4th century B.C. after which an interim period of activity is attested before the area was prepared for the construction of the South Stoa.³⁶³ Meanwhile, Building II was destroyed no earlier than the end of the 4th century B.C.³⁶⁴

The beginning of the construction of the South Stoa must be placed sometime soon after the terrace was constructed. There is no reason to believe that the terrace was for anything other than the stoa and no material recovered in the fill between the terrace and the stoa suggests a long period between its construction and the stoa's construction. We should, therefore, expect a date sometime around ca. 300 B.C. for the construction of the South Stoa.

Placing the construction of the South Stoa at the end of the 4th century B.C. requires rethinking the historical circumstances of its construction and function. Moreover, the new date for the South Stoa has implications regarding stylistic comparisons with other buildings. Previously, there were several buildings which were thought to have post-dated the South Stoa based on stylistic criteria. Most important among the stoa buildings affected

³⁶³ Williams and Fisher 1972, 153. The interim period of activity is attested in three places: First, rebuilding of the terrace wall along the south side of the sunken area (Building I), second, installation of a basin, and third, a "tenuous change" in the stratified soil at the level of the socle course of the east wall of Building II, which contained scattered roof tiles (154).

³⁶⁴ Ibid. 171.

by this new date are the Stoa by the harbor at Perachora and the Stoa in the Asklepieion at Athens.³⁶⁵

A new date of ca. 300 B.C. for the South Stoa raises many questions regarding the function of the building and the historical circumstances of its construction. Stoas could have a number of functions within the city and those functions could change over time. It had been suggested that the South Stoa was built for a specific purpose connected to the Corinthian League founded by Philip and, later, continued under Alexander.³⁶⁶ Broneer's reasoning for tying the South Stoa to the Corinthian League has to do with the character of the building, rather than any direct evidence for a connection. If the stoa served a public function unrelated to commercial activity and if the backrooms were for dining and the upstairs for sleeping, the building would have served as an luxurious hostel capable of catering to a large number of people. The accommodations would serve the needs of a league gathering.

As we have seen, based on the revised date of construction, the South Stoa could not have been built for the establishment of the 'Corinthian' League, since it was constructed a considerable time after the league was established and after the deaths of both Philip and Alexander.³⁶⁷ It is still possible, however, that the South Stoa was connected to a later incarnation of the league, as the league was re-established at the end of the fourth century

³⁶⁵ These two buildings are dealt with below regarding stylistic comparison.

³⁶⁶ Broneer 1954, 98.

³⁶⁷ Williams (1995, 45), at one time, suggested the construction of the South Stoa was associated with the tyrant Timoleon's activities in Sicily, particularly his victory at the Krimesos river (341 B.C.). A series of inscribed blocks recording this victory were found near the South Stoa and Williams postulated that they were set up on the terrace wall in front of the South Stoa. For Timoleon's activities, see also, Talbert 1974. On the Monument of Timoleon at Corinth, see Kent 1952, 9-18.

B.C. by Demetrios Poliorketes and continued into the beginning of the third century B.C. under the Antigonid dynasty.³⁶⁸

What is possible to say is that based on historical evidence, at the end of the fourth century B.C., there was activity centered at Corinth and Isthmia connected to Demetrios Poliorketes, when he re-founded the Hellenic League, the generally accepted date of which was 302 B.C. We are told that Demetrios called together delegates from the liberated tribes and city-states in Greece at the Isthmian festival that year.³⁶⁹ This league, like the original one, was short-lived, but it is possible that its re-establishment generated building activity at Corinth, which included the South Stoa. A building, capable of housing and feeding a large number of people, would be an appropriate gesture for such occasions as the league would require for meeting and, it could be argued, the South Stoa at Corinth would have been an ideal facility to house and feed a large group of dignitaries. While this might be attractive in theory, there is no definitive comperanda for stoas used to house overnight guests.³⁷⁰

³⁶⁸ The first league is thought to have been initiated after the battle of Chaironeia in 338 B.C. It was refounded by Demetrios Poliorketes in 302 B.C. Parsons (1936, 123) argued that when Demetrios installed a garrison on Acrocorinth in 303 B.C., renovation of the defenses and gate in the long walls took place, including an arched gate in the Eastern wall to Lechaion, which may have been instigated by him. It is just possible that the South Stoa might be seen as part of these renovation activities in the city. Cf. the stoa dedicated to Antiochos I at Miletus, ca. 300/299 B.C. (Kerweran and Rehm 1914, 261-262.)

³⁶⁹ See Hammond and Walbank (1988, especially 269-270) on this period. Modern scholars refer to this organization as 'The Hellenic League'. The official name of the league as it was referred to was κοινὸν Συνέδριον or just Συνέδριον in the major inscription from Epidauros on the league, I.G., IV², 68, section I, line 8; III, line 70; IV line 115 (also SVA III. 446); For another important inscription mentioning the league see Schweigert 1940, 348-351. Also, Plutarch (*Demetrius*, 25.3) states ἐν δεισμῶι κοινοῦ συνεδρίου... .

³⁷⁰ One exception would be the Abaton in the Asklepieion at Epidauros.

One problem with this idea is that the league was established at the Isthmian festival and there is no definite indication that the officials and delegates were quartered anywhere other than in the Isthmian sanctuary itself. We have no evidence for accommodations at Isthmia at the end of the fourth century B.C., but some form must have existed.³⁷¹ Alternatively, the delegates might also have been housed in more temporary structures, such as tents or even private houses either at the Isthmus or at Corinth. As it is, there is no firm evidence to link the South Stoa with the refounding of the league by Demetrios other than the coincidence of date and the fact that Corinth became the *de facto* headquarters for the garrison left behind by him. The South Stoa could have been constructed for future gatherings of the league and any other official activities associated with it. If this were the case, most likely the rooms would have been used by the city for other purposes when not in use for the league. Regardless, the league was short lived, and the building would have been assigned another purpose shortly after construction.³⁷²

³⁷¹ Buildings, of some form, for accommodation of athletes are remarked upon in an inscription of Roman date. The inscription was apparently on display at Corinth near the Bema in the Roman period. It mentions a ruined stoa and the construction of fifty new rooms at Isthmia to be used by athletes for the duration of the Games free of charge (Broneer 1939, 181-190). The excavations at Isthmia have not, as yet, uncovered evidence of structures to house athletes. Pausanias (6.21.2) mentions rooms for athletes adjoining the wall of the eastern stoa of the gymnasium at Olympia.

³⁷² It is possible that the Hellenistic phase of the theater at Corinth is also associated with league activity in 302 B.C. (see Stillwell 1952, 132). It has already been noted above that the workmanship on the extant blocks from this phase of the theater shows similarity to that of the South Stoa.

Function of the Backrooms

The evidence recovered from inside the backrooms does not provide definitive proof for the function of the building with any certainty. The wells themselves only seem to compound the problem, as having one in almost every room seems excessive, as is discussed below. Broneer posited that the rooms functioned as taverns, but how they would have worked as such has never been explored in detail.³⁷³

That the rooms have off-center doorways raises the possibility of their having couches for dining. Various reasons have been put forward for doorways set to one side, including the relationship of doorways to the wells, windows, and even the common usage of one side of the door while the other remains shut.³⁷⁴ One of the most obvious reasons to have off-center doorways is to accommodate dining couches, placed around the perimeter of the room. The correlation between dining couches and off-center doorways is never a certainty, however, without supporting evidence and in this case it should be seen only as one of the criteria necessary for assigning couches to the interior and a dining function to the rooms. The best evidence for dining

³⁷³ The wells themselves contained material evidence spanning a period of time from the end of the 4th century B.C. up to ca. 146 B.C., including public dining debris in the form of a large number of cups and serving vessels for wine, which led to the suggestion that dining took place in the rooms. The well deposits appear to comprise again dumped fills, including destruction debris, from top to bottom with no certainly definable use levels, so any discussion of occupational use would seem to be hazardous. See Edwards 1975, 196-198 and deposit summaries 95-118, for discussion of the character of these deposits. See Broneer 1954, 62-64, 98, for a discussion of types of vessels found in the wells which led him to conclude that the stoa functioned as a tavern.

³⁷⁴ See Broneer 1933, 556, on the asymmetry of the doors as a response to the placement of the wells in the rooms; Thompson 1954, 43, for the accommodation of windows and usage of door valves. Thompson notes that the market building at Aigai also has off-center doorways, to the right of center like the South Stoa, and windows.

couches would be evidence of stone couches themselves, but none are known for the South Stoa. The second best piece of evidence would be a raised border sill along the perimeter of the room from placement of the couches, which again is lacking in the South Stoa rooms.

Nevertheless, the question of whether or not couches fit in the backrooms of the stoa or how dining might have taken place without standard couches must be addressed considering the fact that Broneer was confident that the rooms were taverns for public dining and the doorways leading into both the front and back rooms are off-center.³⁷⁵ It has been suggested that the South Stoa doorways are off-center for the purpose of accommodating windows, but while windows have been restored in the walls leading to the far back rooms, there is no certain evidence that the front rooms had windows, so there is a possibility that the provision of off-center doorways was for dining couches. It is theoretically possible that windows existed at a higher level above the couches. It is therefore necessary to at least determine whether or not couches inside the rooms are a possibility given the evidence of off center doorways.³⁷⁶

Miller, in his discussion of Prytaneia, analyzes the evidence for couch sizes from various sites and ultimately derives a standard size, which with minor variations, seems to exist in several different architectural contexts

³⁷⁵ At Labraunda the excavators have proposed placing eleven couches inside each of the six backrooms of the East Stoa, seemingly based solely on the evidence of off-center doorways. Here the doorways are also accompanied by windows (see Hellstrom 2007). It is assumed that the stoa was used for sacrificial meals and sacred festivals.

³⁷⁶ See Coulton (1976, 88), where he argues that because the doorways of the South Stoa are off-center to the right, the couches would have to be for left-handed diners, which would seem to be an impossible arrangement. This is true if the couches are of the so-called standard size, but this may not be the case.

where dining on couches are present.³⁷⁷ He posits an average of 0.82 x 1.80 m for the dimensions of a normal couch.³⁷⁸ One problem with averaging the dimensions of the couches is that the differences in his table amount to 0.14 m. for the width and 0.19 m. for length. This amount begins to make a difference when a series is supplied around the perimeter of a room and raises concern as to the efficacy of employing an average at all.

If we attempt to fit a standard couch size as ascertained by Miller into the rooms of the South Stoa, it is clear that the rooms do not satisfy the requirements in terms of space, unless major adjustments are made to couch size or some couches are left out. One immediate problem would be that the couch on the east side of the doorway would have the head in the corner and be blocked in by the adjoining couch along the east wall. The couch in the south east corner would have a similar arrangement. **Fig. 146** The couches could be extended in length and still fit the space, although the same problems would exist. **Fig. 147**

³⁷⁷ See Miller (1978, Appendix B, 219-224) on the criteria necessary to assign dining couches to rooms.

³⁷⁸ Miller (ibid.) Table 2.

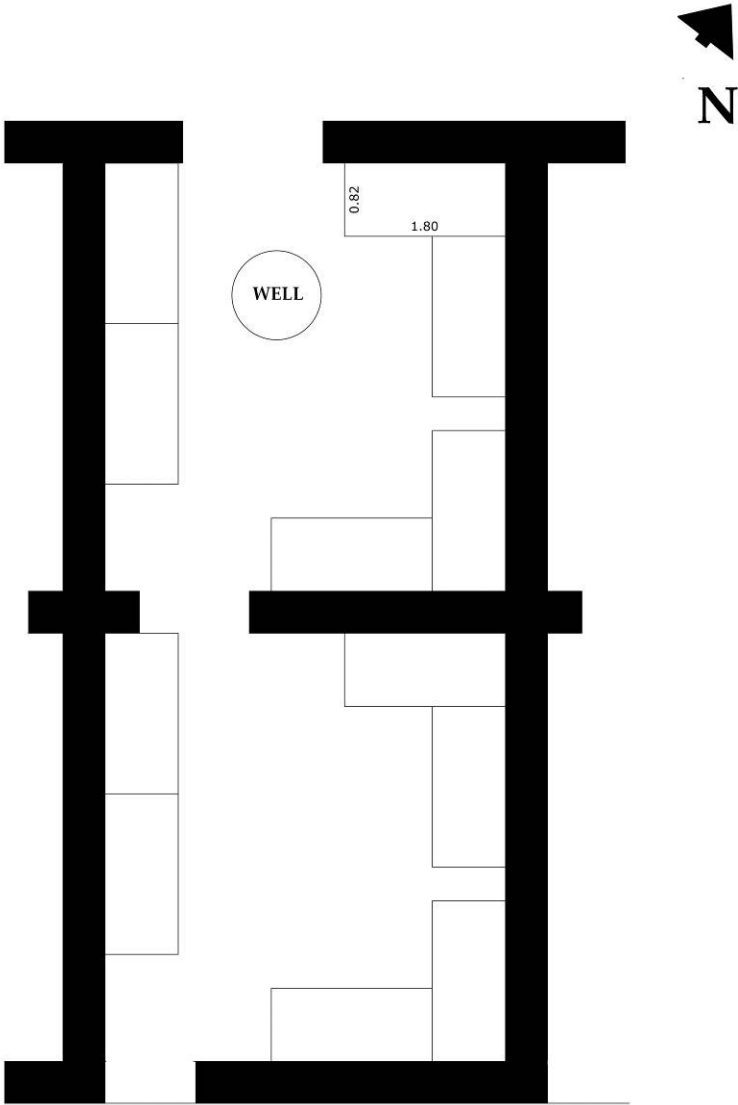

**SOUTH STOA ROOM SUITE
WITH DINING COUCHES OF STANDARD SIZE**

Fig. 146. Rooms shown with addition of dining couches of standard size (0.82 X 1.80).

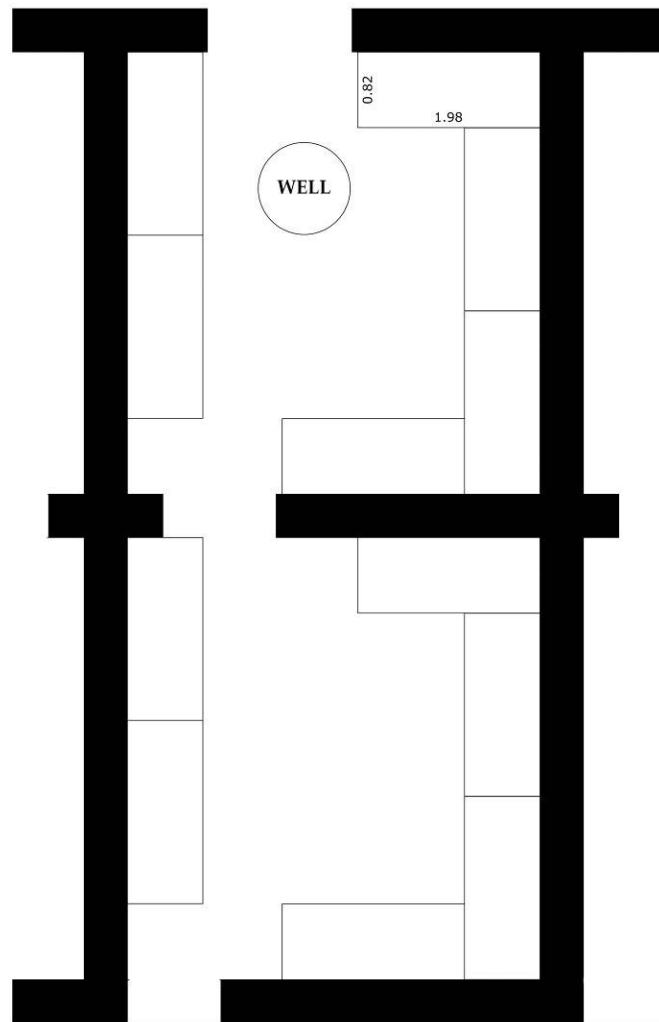

**SOUTH STOA ROOM SUITE
WITH DINING COUCHES OF MODIFIED LENGTH**

Fig. 147. Rooms with addition of dining couches using a modified length of 1.98 m. for couches

The only way for couches to fit in the front room would be to have only two along the east wall and one along the south wall. Couches along the west wall would have to be omitted because the doorways would be partially blocked and there would be little space for foot traffic due to the wells inside the rooms. The wells also cut off nearly all the space for dining tables.

It is clear that any arrangement for standard dining couches and tables in the front rooms would involve compromising most of the space and the result would be awkward. If the rooms were designed for dining, no practical solution for couches of standard size is apparent.

The far back rooms also may have had windows on the east side, which could explain the off-center doorways, but, in any case, couches would not fit easily in these rooms either. The doorway into the far back rooms is even more off-center toward the right, leaving enough space for a couch inside the doorway on the east to be moved out from the corner, but the doorway on the south wall would prohibit couches in the southwest corner and along the west wall. We are left with space for only four couches, and perhaps a fifth in the center of the west wall.

In sum, the relationship of room size and off-center doorways does not accommodate “standard” or even modified dining couches neatly in either the front or back rooms. If some form of dining did take place in the far back rooms, then the front rooms, with their wells, could have been where food preparation took place, but then diners would have to pass through the kitchen on the way to the dining room, which would be an awkward arrangement. None of these solutions is particularly appealing and we are left with uneasy solutions for making the lower floor rooms into dining facilities with anything approaching standard dining couches.

In order for the lower rooms to accommodate dining, it is necessary to imagine some other type of arrangement for which we have little evidence to go on. Perhaps couches were not of the standard size that has been proposed for buildings elsewhere, or some were of a different size. Another

entirely different possibility is that dining in the South Stoa was performed without reclining couches, in which case there could have been wooden benches around the perimeter. In any case there is no evidence, other than the circumstantial evidence of the off-center doorways, to suggest that couches go in any of the lower rooms.

A larger question raised by the dining hypothesis would concern the rationale for having so many separate dining areas with the same number of cooking areas behind, plus such a large number of wells to service them. One possibility would be that some form of hierarchy existed to make separate small dining areas necessary. Evidence does exist for the separation of small groups into dining compartments, but it is the number of rooms set aside for this purpose that is problematic in the South Stoa.³⁷⁹ In any case, given the monumental nature of the building, and its prominent placement in the city, any dining in the South Stoa would have to be considered a public and or elite enterprise.

The fact that the staircase to the upper floor starts just outside the front rooms and runs up toward the exterior colonnade before making a return implies a sense of privacy for the upper floor, since access to the upper floor is made from the interior rather than the exterior of the building. This would lend credence to a private function for the lower floor rooms as well, but without more evidence we cannot say for certain that dining took place in the lower rooms.³⁸⁰

³⁷⁹ For dining in separate small groups, we have architectural evidence, i.e. the prytaneion buildings identified by Miller; the dining facilities in the Sanctuary of Demeter and Kore on Acrocorinth; South Stoa I in the Athenian Agora.

³⁸⁰ The material from the wells includes cups and household wares, which would suggest a dining function, but there is no definitive reason that this material, which

Function of the Wells

Whatever the scenario for possible dining facilities in the South Stoa, thirty one out of thirty-three rooms have wells, which is an extravagant feature for any stoa. There is no obvious reason to have so many wells next door to one another for dining or commercial reasons. The main function of the South Stoa wells must have been to draw water.³⁸¹ There are only two known parallels of stoas with wells inside the rooms. The earlier of the two is a stoa in the agora at Pella, which may have had a commercial function associated with pottery production.³⁸² The second is the stoa at Kameiros on Rhodes, which also may have had a commercial function, since it is located on the agora.³⁸³ Nothing definitive has been said, however, about the use of the wells in either of these buildings, but preliminary findings among destruction debris in the rooms of the stoa in the agora at Pella indicate that it is likely to

was dumped into the wells effectively putting them out of use, must be from the South Stoa rather than from other nearby structures.

³⁸¹ The suggestion by Broneer (1954, 61) that the wells served mainly to chill wine is not supported by any solid evidence. There are no other occasions where such elaborate facilities for chilling wine exist in the archaeological record and the two literary references referred to by Broneer in support of this theory, are both circumstantial (see Aristophanes, *Ekkl.*, lines 1002-4; Athenaios, *Deipnos.*, III, 124d). Athenaios does refer to wine being chilled in a well, specifically quoting two ancient authors who mention the cooling of wine by this method. This occurs in the context of discussing the consumption of cold liquids in general. What is certain from this testimony is that wine could be and probably was chilled by this method and perhaps a subsidiary use of wells was to cool wine, and other food stuffs too for that matter, but this is not enough to assert that the main function of the South Stoa wells was for this purpose. Broneer's argument (1954, 61) that the well heads were not of sufficiently hard material for the wells to be used chiefly for pulling up water is perplexing as the well heads are made of stone. It is interesting that the passage from Athenaios concerns extravagant dining behavior in which Alexander and his successors are mentioned several times for adopting Persian excesses. If the Stoa was used by Demetrios, who was known for his lavish lifestyle, perhaps we should expect such extravagant use of the wells. I know of no other references to the ancient Greek practice of chilling wine in this way (as a general rule).

³⁸² The colonnades of the agora at Pella await full publication. See Lilimpaki-Akamati, and Akamatis, et al. 2011, 67-72.

³⁸³ For the stoa at Rhodes see Jacopi 1932-39, 241-249.

have served as a pottery production center, in which case the water would have presumably been necessary for this activity. This would be one of the few instances in which the material evidence recovered from a stoa speaks to actual use of the building.

The stoa at Kameiros is longer than the South Stoa, at 207 m., and sits on a hill dividing the agora in front of it from a sanctuary behind it. The building has fourteen wells spaced almost evenly among forty-six rooms. Coulton suggested that the wells served a function related to dining, citing the South Stoa as a parallel, but they could just as easily have been for industrial activity.³⁸⁴ To date, no other material has been described to support their use.

In keeping with the idea of industrial activity, it is possible that the South Stoa at Corinth could have been part of a major re-organization of the area for commercial purposes in the late 4th to early 3rd centuries B.C., but no other buildings in the vicinity support this idea. The evidence for this would be circumstantial and have to do more with the character of the building as a lavish and large stoa. The rooms on one or both levels could be for shops, though no use material has been found to indicate commercial activity other than the possibility that one deposit under the floor in room III might indicate that the manufacture or sale of terracotta figurines took place there in the 3rd century B.C.³⁸⁵ The number of wells might be an indication of industrial activity requiring water, but for what purpose is not clear. The parallels, such as they are from Pella and Kameiros, are not definitive, but the evidence from Pella could support the idea of an industrial function related to terracotta

³⁸⁴ Coulton 1976, 61-62.

³⁸⁵ This deposit was noted above in connection with the date of the building.

production, in which case the terracottas under the floor in room III might be related.

Other Possible Functions for the Building

In addition, it has been suggested that the South Stoa could have been used for the accommodation of athletes in training for the Isthmian games.³⁸⁶ The evidence to support this claim lies with Pausanias' reference to athletes at Olympia, who first had to participate in training at Elis. Williams suggested that the same might have applied for athletes intending to participate in the Isthmian games, who first had to undergo training at Corinth, in which case the South Stoa could have functioned as a large hostel for athletes.³⁸⁷ The stoa was constructed directly next to the dromos, which lies in front of the Stoa terrace. If we are to see the dromos and the stoa as a unit connected with athletic training, they would have to be seen as a separate training facility apart from the gymnasium known to Pausanias, which has been located north of the theater in a completely different area of the city.³⁸⁸

Since the South Stoa appears to be the same, or nearly the same length, as the dromos to the north, a connection between the two is plausible. The Hellenistic racecourse also appears to have been constructed at roughly the same time as the South Stoa.³⁸⁹ The fact that the South Stoa might be as long as the dromos at Corinth, and therefore a full stadion in length, raises the question as to whether or not the colonnade might be considered a covered

³⁸⁶ Williams 1970, 39. At Olympia, Pausanias says that athletes first had to participate in training at Elis. He describes a gymnasium complex at Elis for this purpose (Pausanias 6. 23).

³⁸⁷ Williams, *ibid.*

³⁸⁸ For a Gymnasium located north of the theater according to Pausanias, see Williams (forthcoming).

³⁸⁹ Williams (1970, 5-6) places it in the third to fourth quarter of the 4th century B.C.

dromos, or *xystos*. The requirements for a *xystos*, as far as can be determined from the three secure examples from the Greek world, are a roofed colonnade with a running track inside, that includes some form of starting line and presumably makes allowance for turning at both ends. The *xystoi* for which we have evidence are arguably the length of a stadion, given discrepancies of several meters for length, and in one case has starting posts at one end.³⁹⁰ Also based on the evidence, *xystoi* are simple, one storied, roofed colonnades, with an external and internal colonnade, but without rooms.

If Romano's stadion length for Corinth is correct, the South Stoa length would be a Corinthian stade measured inside the building from the second column to the second to last column, but there are several arguments against it being a *xystos*. The interior space for running is hindered by a staircase in the colonnade at the west end (and possibly one at the east end), which would interfere with the runners' turning ability and would reduce the usable length. There is no evidence for starting posts, which arguably may have been removed over the course of the building's use, but they are nonetheless absent. Perhaps most importantly, the South Stoa would appear to be too grand a building for such a purpose, as it is much more elaborately appointed than any of the known examples of *xystoi*, unless it combined other functions in addition to being a covered running track, in which case it would be an unparalleled type.

³⁹⁰ In the agora at Amphipolis, there is a stoa approximately one stade in length, with starting posts preserved in situ. Very little has been published to date on this stoa, but it appears to fulfill the requirements for a true *xystos* and is definitely related to other athletic complexes next to it. The other two *xystoi* are the Stoa by the Gymnasium at Delphi and the stoa by the Gymnasium at Elis; also at Olympia in the stoa on the west side of the Gymnasium, which is no longer preserved.

Moreover, besides the dromos in front of the stoa, there is no evidence for a gymnasium complex or palaistra in the vicinity. To make the South Stoa a *xystos*, one would have to argue that a dual function of hostel and *xystos* obviated the necessity of having a palaistra, or would have to posit one in the vicinity for which the evidence is lacking and ignore the problems associated with not having starting posts or adequate room for turning inside the stoa.³⁹¹ It therefore seems more likely that the length of the South Stoa, although it might share or be close to the length of the dromos, did not serve as an indoor running track, but was simply conditioned by topographical considerations, that being the length necessary to bound the southern side of the pre-forum area. In addition, the number and size of the rooms inside the stoa may have been what dictated its overall length.

³⁹¹ There is one piece of evidence for an interior courtyard, consisting of a re-entrant corner column fragment built into a later foundation to the west of the stoa. The workmanship is similar to that of the stoa and could be early Hellenistic. The proportions would make a column approximately four to five meters tall. A re-entrant column would imply an interior courtyard space, such as would be necessary in a palaistra, but no foundations for such a building have been found in the area; nor does there appear to be adequate space for one, unless it were in front of the stoa along the west side of the forum area.

Part V

Chapter 19

Influences on the South Stoa

Multi-Level Stoas

The South Stoa at Corinth was constructed in an era that witnessed the development of large two storied stoas, in cities throughout the Greek world. The construction of multi-leveled stoas is generally thought to have been influenced by Pergamene building programs in the Hellenistic period, but the earliest attested stoas with a façade of more than one storey are on the mainland of Greece at Athens and at Perachora, and both are dated to the end of the 4th century.³⁹² These two stoas are modest in comparison with those that came later under Pergamene influence.³⁹³

The earlier of the two stoas is the East Stoa in the sanctuary of Asklepius at Athens, where the second storey backs onto the face of the south slope of the acropolis. The building has been dated to the middle decades of the 4th century B.C, although Townsend dates it to the end of the 4th century.³⁹⁴ The façade of the stoa is Doric for both levels, which presents design issues having to do with the proportions in the upper storey but the evidence clearly exists for the reconstruction. As Coulton has remarked, the

³⁹² Coulton 1971, 183-184. See Dinsmoor 1950, 292 ff., for discussion of the “Pergamene type”.

³⁹³ Chronologically, one of the earliest would be a stoa at Brauron if it can be proven to have two storeys. An inscription from Brauron dating to the 4th century B.C. refers to a stoa with a second storey. The word used is *διστεγής* meaning “of two storeys”; *επιδιστεγον* means “double roofed”. I thank Molly Richardson for the reference to the Brauron inscription. Also see Coulton 1971, 181-84.

³⁹⁴ The main discussion of this building is still Allen and Caskey 1911, but see also Townsend 1982, 42-89; especially p. 76 on a date at the end of the 4th century.

problem is in carrying up the proportions in the traditional way associated with temple cella colonnades, where the taper continues from lower columns to upper columns when there are two tiers of columns. This works when there is only an architrave, not a full entablature as in the stoa, separating the two levels.³⁹⁵ In any case, the two levels of Doric on the exterior offer little in the way of comparison with the South Stoa at Corinth.

The stoa by the harbor at Perachora has been dated by Shoe just after the South Stoa based on stylistic criteria, but Coulton assigns it to ca. 300 B.C., making the two buildings roughly contemporary.³⁹⁶ The small L-shaped stoa was fitted with an upper storey of Ionic pier columns on the exterior. Across the bay from Corinth, Perachora was under Corinthian control in the 4th century, but aside from the use of Ionic pier columns on the exterior as perhaps a development of interior equivalents in the South Stoa, and antifixes of the roof, the comparisons are few between the two buildings.

Precedents: Superimposed storeys

Two-storied buildings were not something new in the 4th century B.C. Certainly in domestic architecture there is evidence that houses could have had more than one storey, but based on the evidence available, few stoas were multi-leveled if at all, before the end of the 4th century. One possible exception is South Stoa I in the Athenian Agora, which possibly had a split level design of two storeys for the back rooms and a one storied façade. This

³⁹⁵ Coulton 1976, 105.

³⁹⁶ For the date, see Coulton 1976, 56. Shoe (1936, 74) dates the cyma reversa geison soffit of the stoa at Perachora "at least as late as the second half of the 4th century." The hawksbeak of the Doric geison crown, she dates to the end of the 4th century at the earliest (1936, 115). The main work on this stoa is by Coulton 1964 and 1967.

relatively modest stoa, dating to the 5th century B.C., with stone socle and mudbrick walls, perhaps influenced the design of the South Stoa at Corinth to the extent of having a split level interior with an upper storey, if indeed its reconstruction as such is correct. **Fig. 148** The upper floor was restored as having rectangular pillars overlooking the road behind the stoa to the south. **Fig. 149** The front wall of the backrooms seemingly presents the biggest problem for the reconstruction of an upper storey, if it is entirely of mudbrick above a stone socle and rises two storeys, but mudbrick walls can easily rise two or more storeys.³⁹⁷ The back retaining wall is less of a problem if it was entirely of stone, as restored. The evidence on site suggests that the retaining wall steps down toward the front, giving the wall a buttressed effect, further strengthening the cross walls to support an upper floor. If the stairway toward the middle of the back rooms functioned as Thompson suggests, the roof at the back of the stoa would have to be significantly higher than one storey or the stairs would project through the roof, unless the stoa was broken at this point, leaving the staircase unroofed, which does not appear to be the case.³⁹⁸

³⁹⁷ A split level design for South Stoa I in the Athenian Agora was first proposed by Thompson (1968, 46-48). The stairs apparently are a later addition. The upper storey has been objected to by Coulton (1976, 44) on three points. The first, that the front wall is of mudbrick, but there are plenty of parallels for two storey mudbrick walls. The second, that the terrace wall is already overtaxed, is offset by the buttressing of the cross-wall blocks. The third, concerning parallels this early, is undermined by an inscription that has been interpreted to imply that a stoa at Brauron had an upper storey.

³⁹⁸ Thompson 1968, 46-48.

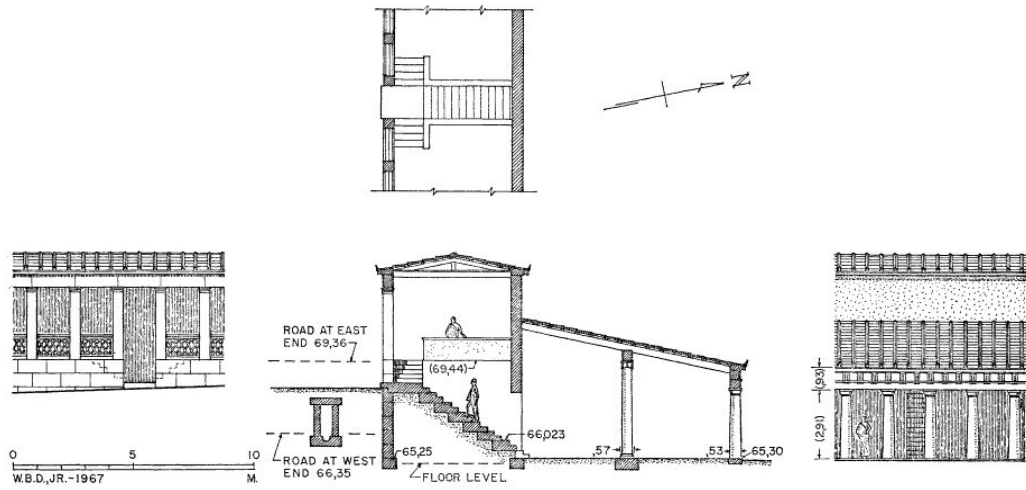

Fig. 148. South stoa I details and elevation as restored by Dinsmoor, Jr. (Thompson 1968, Fig. 2).

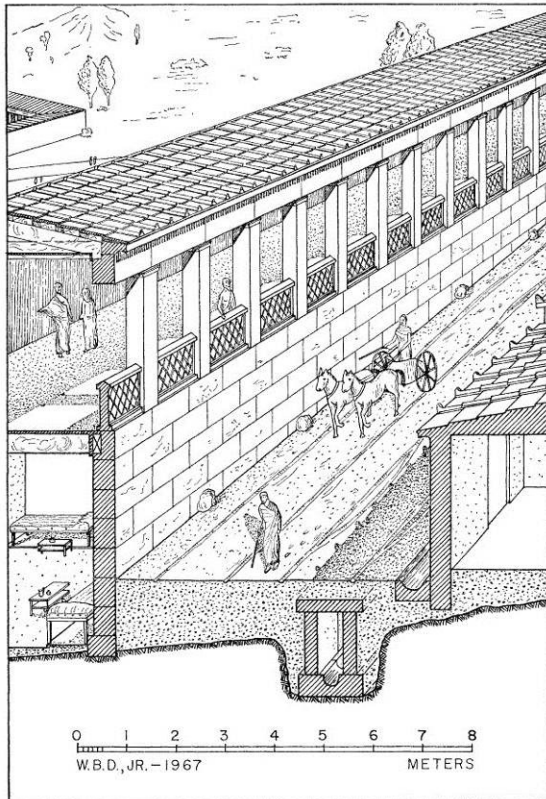

Fig. 149. South stoa I, restored perspective. View from southwest. As restored by Dinsmoor, Jr. (Thompson 1968, Fig. 3).

A more circumstantial piece of evidence for a two-storied stoa in the 4th century comes from an inscription at Brauron.³⁹⁹ The inscription mentions an upper level (ὑπερῶα) in the context of a discussion of the rooms (οἴκοι), which has been interpreted by Bubenheimer and Mylonopoulos as referring to the rooms of the Π-shaped Stoa.⁴⁰⁰ If this inscription is referring to an upper storey in the Π-shaped stoa, it would be the earliest dated stoa with an upper storey. The stoa was published by Bouras, who conducted an extensive investigation of the architectural remains and restored it as one-storied. No elements of an upper storey superstructure have been put with the stoa to support the idea of it having an upper storey.⁴⁰¹ If the second storey was only above the rooms behind the colonnade, the interior of the stoa at the lower level would remain unchanged and we should envision a split-level design.

Fig. 150

³⁹⁹ For the inscription see especially, SEG XLVI 133, XLVII 134. I thank Molly Richardson for bringing this to my attention. The inscription is a law of the *nomothetai* and deals with building repairs in the Sanctuary of Artemis at Brauron. It has been tentatively dated ca. 250 B.C., but may belong in the 4th century B.C. The full inscription has not been officially published, but a photograph of it has been published in *Scientific American* (1963, 208, 118) and has received partial publication by Bubenheimer and Mylonopoulos (1996, 7-23), who discuss the parts of the text concerning the buildings mentioned in it. See also Travlos 1988, 56. Thompson (1968, 48-49, especially note 16) appears to refer to this inscription in passing, as evidence for an upper storey above the rooms adjacent to the stoa at Brauron. On the term ὑπερῶα with reference to upper storeys in stoas, see the discussion by Coulton (1976, 3-4).

⁴⁰⁰ Bubenheimer and Mylonopoulos (1996, 17-18, on the upper storey).

⁴⁰¹ See Bouras 1967.

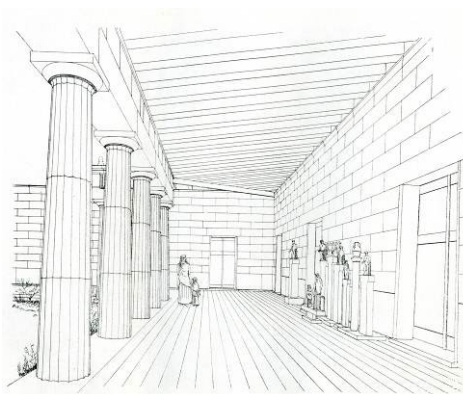

Fig. 150. View looking west inside the colonnade of the Stoa at Brauron (Orlandos 1961, Fig. 21).

A two storied building in a sanctuary context dated to the late 4th century B.C. exists in the sanctuary of Asklepieion and Lerna at Corinth. **Fig. 151** The North wing is restored with a staircase leading up to the abaton and north colonnade.⁴⁰²

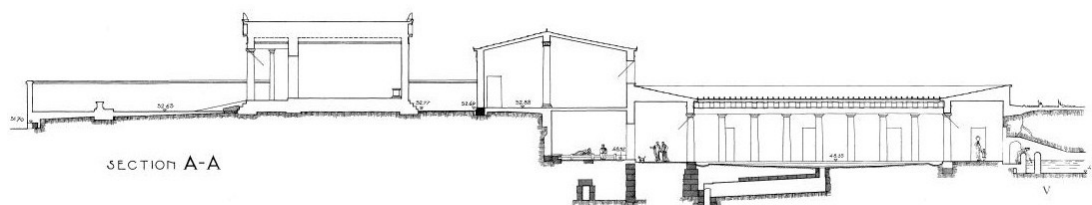

Fig. 151. E.W. section through the Asklepieion and Lerna at Corinth, showing central complex on two levels (Roebuck 1951).

In this case, the topographical situation lends itself to making the central abaton complex on two levels and in fact demands it. A similar two storey abaton has been restored at Epidauros, but the extension possibly dates from the Roman period.⁴⁰³ Here, the extension is set on a basement level, which makes it similar to the central building in the Asklepieion at Corinth. **Fig. 152**

⁴⁰² Roebuck 1951, 51-55; Plate 4²; Plan A.

⁴⁰³ The original section of the building has been dated to the first half of the 4th century B.C. The extension is possibly Roman. See Roux 1961, 291-302.

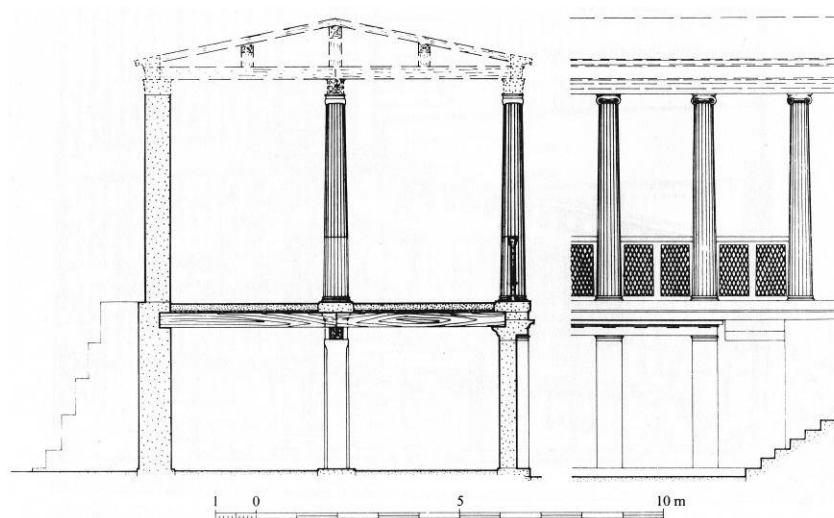

Fig. 152. Epidauros, Abaton Extension, section and elevation (Coulton 1976, Fig. 10).

In monumental architecture, superimposed colonnades existed already in temple design from the 6th century B.C. The interior of the cella might have two tiers of columns with reduced proportions, compared to the exterior peristyle and porch columns, reaching to the ceiling. These colonnades were carrying far less of the load from the roof if any, though they would have supported the ceiling beams spanning the cella. Aesthetically, these double colonnades were hidden behind the wall of the cella, where they would never be seen against the exterior colonnade.

A superimposed colonnade in the interior of a stoa is a different matter and it has been objected to on aesthetic grounds, since, when viewed from the outside, the exterior colonnade would be broken by the entablature of the interior colonnade.⁴⁰⁴ To what extent this was an aesthetic consideration in antiquity, we have only the evidence that, barring the South Stoa at Corinth and one other questionable example, the practice of constructing two-tiered

⁴⁰⁴ Coulton (1976, 102-103) states that a “two storied arrangement is unsatisfactory” for the interior colonnade of a stoa.

colonnades in stoas was not done.⁴⁰⁵ Plommer thought that the Oikos of the Naxians should be given a two-tiered internal colonnade based on the proportions of the preserved internal column fragments.⁴⁰⁶ His reasoning has to do with the load that the colonnade would have carried, which would have been substantial considering the roof tiles are in marble. The question of load bearing capacity on columns has been little explored, but would have been a consideration, although it is not entirely clear that two tiers of columns with an intervening entablature would be more stable than a single slender column with an entablature. In the case of internal columns that were larger than the external colonnade, the evidence is clear that the columns were meant to reach as high as needed to support the roof ridge.

A slightly different practice of having a colonnade above a wall or supported by columns, creating an upper storey loggia, occurs in Macedonian palace architecture in the 4th century B.C. In Macedonia, residential palace complexes had an upper storey, restored often with an open loggia of piers facing outward and colonnaded courtyards on the interior. The Palace at Vergina/Aigai is an example containing both upper storey pier columns and a colonnaded interior courtyard. This palace is usually dated to the second half of the 4th century B.C.⁴⁰⁷ The “palace” structures at Pella are like that of Vergina/Aigai. At Vergina/Aigai and Pella there is ample evidence on the site (pier columns with parapets) to suggest a second storey with a loggia of pier

⁴⁰⁵ Shear, Jr. (1970, 244) suggested that the Stoa Basileus possibly had a two tiered internal colonnade. Otherwise, the interior columns were exceedingly slender. But see Coulton 1976, 101, who disagrees that it was necessary.

⁴⁰⁶ Plommer 1970, 186-7.

⁴⁰⁷ See Nielson 1994. Evidence on-site consists of pier columns with Ionic capitals, which would have formed part of the balustrade.

columns, but the reconstructions of these upper storeys have not been fully explored yet.

Related to this type of palace construction are the domestic Pastas-type houses at Olynthus from the 4th century B.C. **Fig. 153** The Pastas-type house has an interior courtyard with an open veranda that continues on either side of the courtyard as enclosed corridors. A rudimentary staircase would provide access to the upper storey. What is noteworthy for the purposes of comparison with the South Stoa is the balcony with an upper storey veranda, constructed entirely of wood except for the capitals, which are of stone.⁴⁰⁸ Hoepfner concludes that the Pastas-type house probably shares a connection with Macedonian domestic architecture of the 5th century, or derives its inspiration from Macedonian tomb architecture.⁴⁰⁹

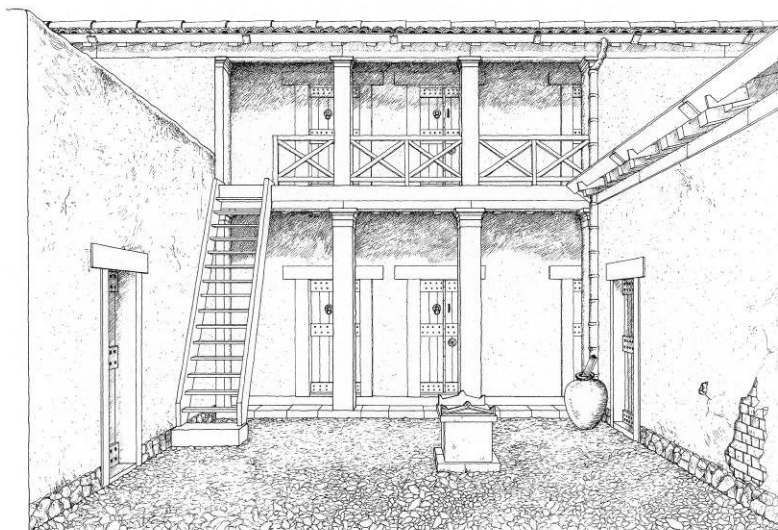

Fig. 153. Pastas-type interior courtyard showing two-storey arrangement with balcony (Hoepfner 1999).

⁴⁰⁸ Compare this with the columns, piers and parapet of stone in the South Stoa. The wooden elements of the South Stoa are confined to the interior entablature and floor beams.

⁴⁰⁹ Hoepfner 1999, 273-274, where he also notes that the quality of the capitals and antae are comparable to good public buildings.

Macedonian two-storied tomb facades may have given some of the artistic inspiration to architectural construction, but tomb facades were applied in a strictly decorative way as opposed to functional support for the structure. Architects, therefore, would seemingly have been much freer to experiment with the idea of superimposing orders and upper storeys on tomb façades. Given the geographical limitations of Macedonian tombs, the inspiration they might have provided would seem to have been largely confined to local architects involved in palace architecture. In any case, it is generally assumed that inspiration for the tombs came from palace architecture.⁴¹⁰ As Hoepfner notes, elaborate construction in domestic contexts is consistent with Macedonian traditions, where there is a vastly different political and social development than in Athens.⁴¹¹ Different political and social developments would certainly have an effect on building traditions, although with Greek architecture, traditions seem to cut across these lines and in Macedonia in particular, the ruling class cultivated a “Greek” aristocracy. This may have led to monumentalizing domestic architecture that was truly Greek. This is not the place to explore the development of domestic architecture, but it is worth noting in the context of influence from and on Greek civic architecture and stoas in particular.

Outside of Macedonia, only one house has been found which has been identified as a Pastas-type house, dated to the 5th century B.C. and it lies in Attica. This is the Dema House excavated near the Dema Wall in Northern Attica. **Fig. 154** The reconstruction is based on the evidence of a single

⁴¹⁰ Nielson 1994, 95-96.

⁴¹¹ Ibid.

column base, which must have been accompanied by several more, fronting a series of rooms with a courtyard.⁴¹²

The Pastas- type house provides evidence of the use of a split level balcony, which most often was probably constructed in wood. The use of stone bases would have had a functional incentive, while the use of stone capitals would have made the houses more sumptuous, in a sense monumentalizing them.

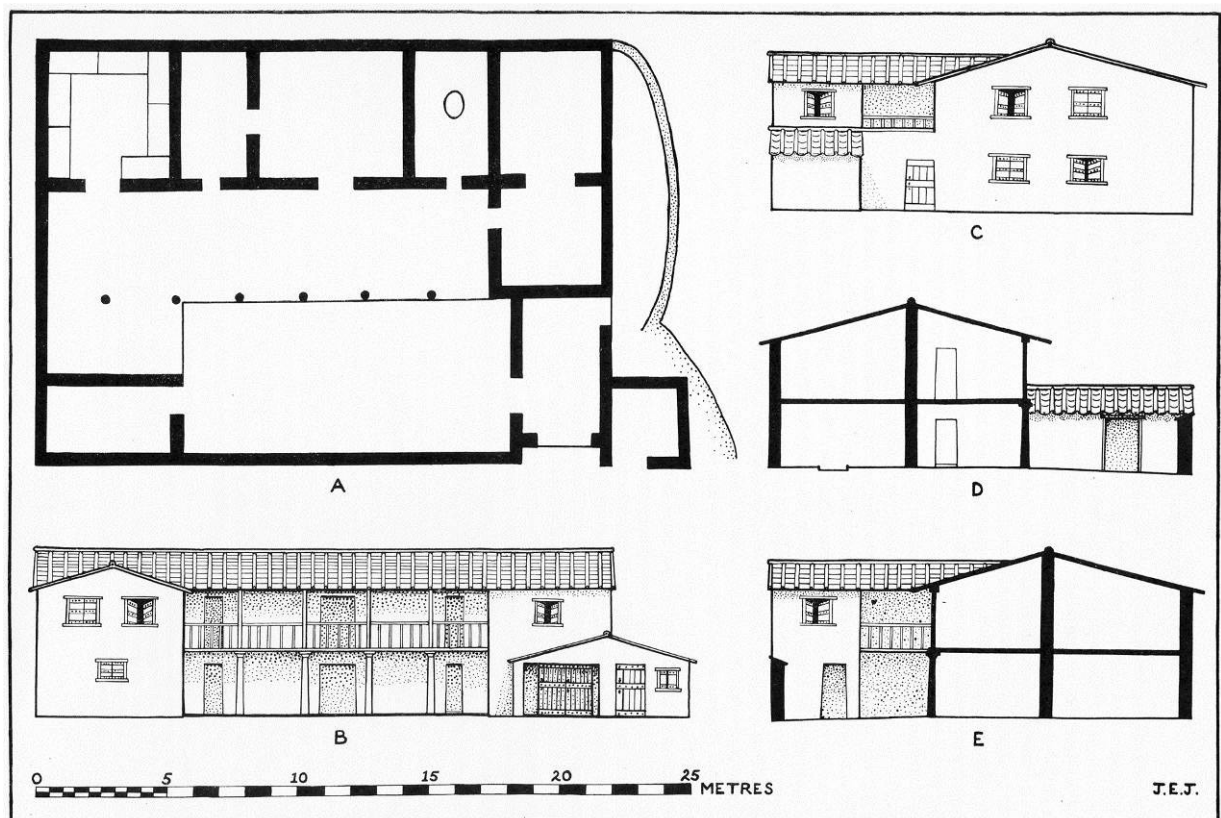

Fig. 154. The Dema House (Jones 1962).

By the end of the 4th century, when monumental stoas with two or more levels begin to appear, they seem to belong to an experimental phase of stoa design. The two earliest, the stoa at Perachora and the Stoa in the Asklepieion at Athens have major differences in design and elevation, other

⁴¹² See Jones, et al. 1962, 75-114.

than that both have two storied facades.⁴¹³ By the later 3rd to 2nd centuries B.C., two-storied colonnades were fairly common, especially in the East. Coulton has discussed two-storied stoas as being largely a Pergamene phenomenon that occurs later in the Hellenistic period, but it is significant that the earliest stoas with two storeys are in Athens and Perachora. The experimentation with structural issues that had to be dealt with in constructing multiple levels was already manifest in designs such as in the Asklepios sanctuaries at Athens, Corinth and Epidauros, though the topography, which gave access to different levels seems to have been an influential factor in aiding the designers by providing support for terracing. South Stoa I in Athens also was influenced by similar topographical considerations, if it was split level, which would make it the earliest of such structures. These buildings then share a common theme of having an upper storey influenced by topographical considerations. This topographical component sets the South Stoa at Corinth apart, as it was placed in an open space on leveled ground.

The study of multi-level buildings from the Archaic period up to the Hellenistic period deserves more attention from a design standpoint, as it would, I think, shed more light on design in civic architecture during the dawn of the Hellenistic period. The discussion above highlights the cases that stand out as possible precursors to the idea of building multi-level stoas in the Hellenistic period. One major problem in assessing the case for multilevel buildings, including those of the Hellenistic period, is the paucity of evidence

⁴¹³ At Apollonia in Epirus there is a large stoa which has upper storey elements and has been dated to the 4th century B.C. Very little has been published about the architecture, so nothing definitive can be said at this time, but the columns and upper storey elements look nothing like fourth century work at Corinth. The fact that the stoa is in Apollonia is interesting, however, as Corinth maintained strong connections with this city throughout the classical period.

or misinterpretation of the evidence that exists in some cases. The lack of evidence on sites is due to the fact that most buildings have been stripped down to foundations with only fragments of superstructure having survived. I believe, however, that more buildings were probably multi-storied than is reported or has been published.

The Stoa by the harbor at Miletos is a case in point. It is restored as a single storied stoa with a flat roof by Coulton, largely because there seems to be no evidence for an upper level superstructure.⁴¹⁴ **Fig. 155** I would argue that the cornice blocks, with horizontal upper surfaces, are precisely the kind used for transitioning to an upper floor, which apparently is missing entirely, and that a terrace, or flat, roof is uncharacteristic for any monumental building of the Greek period. Flat roofs do not occur in Greek architecture of the mainland. The South Stoa cornice with flat topped cornice cannot be expected to go with a flat roof and the lack of superstructure should not preclude the possibility of an upper storey.

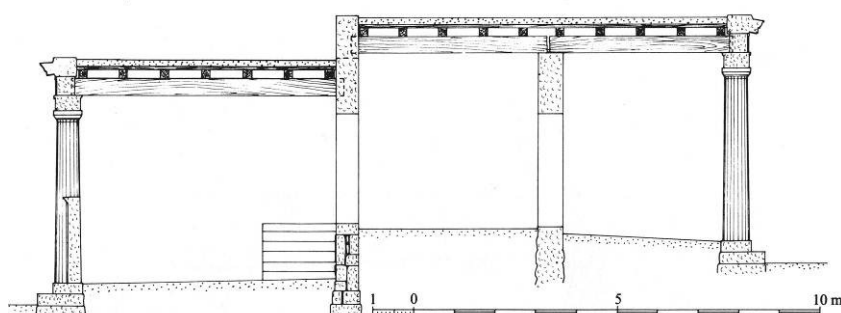

Fig. 155. West wing of the Stoa by the Harbor, Miletos. Reconstruction by Coulton (1976, Fig. 37).

⁴¹⁴ See Coulton 1976, 150 for his idea that the building had a flat roof. The main publication of the building is Gerkan 1922, 4-14, 91. Coulton's argument (149) that island architecture typically has flat roofs is anachronistic since it holds only for earlier periods and the modern period.

Stoa Size

In the Hellenistic period, the length of stoas is determined by topographical considerations and by function, while in the earlier 5th and 4th centuries stoas were designed at a much more modest scale. Prior to the end of the 4th century, the longest stoa known was the Stoa Philipeios at Megalopolis, at ca. 90 m. in length, constructed sometime between 338 and 330 B.C.⁴¹⁵ With the construction of the South Stoa at Corinth, the scale in terms of length changes considerably. It has been noted above that the South Stoa bounded the southern side of the open area, which up to this point had already been largely given over to public use, with a racecourse and ample water supply. Replacing earlier scattered buildings on the south side of the area, the stoa would appear to have been a conscious effort to organize the space. Length, then, can be seen as being tied to topographical considerations of marking a boundary. A comparable situation occurred at Kameiros on Rhodes. There, marking a boundary between sacred and public space was built the longest freestanding stoa yet excavated.⁴¹⁶ Its length is 207 m. and, as discussed above concerning the function of the South Stoa rooms, this stoa also has a series of wells inside the rooms. At Miletos there were two stoas over 100 meters long that are contemporary with the South Stoa at Corinth. The south wing of the stoa by the harbor at Miletus, dated to the late 4th century B.C., was 143.85 m. long. The East building in the South Market at Miletos is 189.20 m. in length 22.69 m. in depth.⁴¹⁷ This building has been attributed to Antiochus. Coulton does not include it as a stoa proper

⁴¹⁵ Coulton 1976, 51.

⁴¹⁶ For the stoa at Rhodes, see Jacopi, 1932-39, 241-249.

⁴¹⁷ For the East Building, see Knackfuss 1924, 31-47.

because he considered stoas to need more than one aisle of columns or for the aisle to be at least half the width. The building, which has two sets of rooms at the back, fronts onto a square with colonnades on three sides and if the front colonnade is seen as part of the building, it should be considered two aisled. The back rooms could be accessed from the rear, like in the South Stoa at Corinth. I would argue that the East building should be seen within the development of stoas in the Hellenistic period, precisely because of these attributes. That it is not a free standing stoa serves to illustrate the ongoing evolution of design, especially in the Hellenistic period where larger complexes subsume and reshape the canonical elements of Greek architecture. While the stoas at Rhodes and Miletos show that long stoas are being built elsewhere at roughly the same time as the South Stoa at Corinth, these examples are in cities where urban planning of long colonnades serving as boundaries is part of the plan from the beginning. At Corinth, the South Stoa is fitted into an already existing, complex urban environment. It is also probably the case that the South Stoa at Corinth is the earliest example of this kind of urban development, where a unified colonnade marks such a boundary.

Slightly later on the mainland of Greece, we see a continuation of stoa development at Thermon, where two long stoas were added; the East Stoa and Middle Stoa were both over 160 meters in length and the Southern Stoa was 184 meters in length. These buildings are assigned to the period of 287-216 B.C. under the Aitolian league.⁴¹⁸ This building program appears to be for the purpose of expanding into open area south of the temple area, but still

⁴¹⁸ Coulton 1976, 58.

within the sanctuary and within the walls.⁴¹⁹ Here again, the South Stoa serves as a precedent for large scale urban development using colonnades to mark space. Stoas arguably already were doing this at Athens and Argos, but in a more limited capacity and smaller scale.⁴²⁰ Once the expansion in length is begun it becomes the standard way that agora spaces and sanctuaries are demarcated and organized. That part of the program at Miletos is under Seleucid sponsorship is suggestive of the influence that Macedonian building activity had in shaping early Hellenistic building programs and the development of large scale stoa architecture which began at this time.⁴²¹

Macedonian Connections

In view of the connections between Demetrios Poliorketes and Corinth and the larger presence of Macedonians at Corinth and Sikyon especially from the mid 4th century B.C. to the end of the 3rd century B.C., it is worthwhile to explore the possible influence of Macedonian building activity in more depth. Previous attempts at making architectural connections with Macedonian traditions have focused for the most part on looking for stylistic parallels. While there may be some cases of influence at the level of details, it

⁴¹⁹ Two long stoas were also planned in the mid to late 4th century on the Pnyx in Athens; the one to the west has an overall length of 149.32 m. This western stoa, may have been planned to be two storied judging by the thickness of the outer walls, which are arguably wide enough to carry a second storey, and the close interaxial spacing of the columns, calculated to be 2.686 m. (See Thompson and Scranton 1943, 272-280). Romano (1985) conjectured that the foundations were for a stadium, but the evidence cited is not conclusive and requires basing a foot unit for the stadium on the overall length at frieze level as determined by Thompson and Scranton for their proposed stoa rather than on the overall length of the foundations themselves.

⁴²⁰ Athens: South Stoa I, 5th c. B.C. (Thompson 1972, 74-78); Argos: South Stoa, E. 4th c. B.C. (Coulton 1976, 217).

⁴²¹ See Winter 2006, 54ff. for discussion of possible Macedonian influence, especially with regard to stoas with wings.

is clear that borrowing of stylistic details is not so easily discernable in the architectural record. Moreover, while local traditions may have assimilated ideas the exchange of those ideas back and forth is not readily apparent. It would seem doubtful that we can extrapolate much in the way of direct influence or connection unless there was more supporting documentation.⁴²²

In the 4th and 3rd centuries B.C., Corinth had a thriving building tradition of its own. This fact raises the question as to how much the local tradition would be influenced by outside forces and how influence might manifest itself. Transmission of influence can flow at least five ways. One involves a specific donor, as in the case of Attalos II and his donation of a stoa at Athens. A second way would be through outsider presence, as in the case of Macedonian control of an area or the actual presence of Macedonian officials. A third way would be by currying favor of outside influence as a show of respect or at least honor, in which a city honors a specific person, as occurred with the Stoa Philipeios at Megalopolis, which until the construction of the South Stoa was the longest freestanding stoa, being constructed ca. 338-330 B.C.⁴²³ One obviously has to be careful not to take these models too far, but they offer possibilities for interaction that might be present in the architectural record. A fourth way for transmission of influence would involve itinerant workshops or craftsmen, which could be connected in some form to the other three avenues of transmission or simply be the result of economic circumstances. This idea has been pursued for a number of sites with varying

⁴²² A good case of both material and inscriptional documentation of direct influence would be the Stoa of Attalos, for which we have Pergamene style capitals and an inscription on the architrave of the building assigning it to Attalos II.

⁴²³ Pausanias 8.30.6. Imperial design, however, was imposed on the provinces by the Romans to some extent, but this kind of comparison would be dangerous. By the Roman period, Greek traditions had slowed and Roman building practice was thriving on a global scale in the Mediterranean.

degrees of success.⁴²⁴ A fifth way could have been by treatises explaining design and construction.

Given the possibility of influence, the next step would be to establish at what level transmission might be present, whether it is at the level of formal qualities such as details or construction methods or at an ideological level that might include building function. The formal qualities of the palace architecture in Macedonia, with courtyards and upper storey balconies, and the related pastas-type house arguably did share a crossing of influence with stoa design as witnessed by the attraction to multi-storied stoas in the Hellenistic period, but these palaces and their shared features are contemporary with the development of multiple storeys in stoas, not earlier.

Hellenistic conventions in architecture also include the laying out of an agora space, such that the borders are lined with stoa colonnades. This application of stoas on a large topographical level can be traced to the Macedonian agora at Pella, where the earliest formal layout of a large open rectangular square bordered by stoas (ca. 202 m. E. to W. and 182 m. N. to S.) dated sometime near the end of the late 4th century B.C., is preserved.⁴²⁵ Although the bordering of agora space can be seen in agoras such as Athens and Argos earlier, as noted above, it is the scale to which it is done that is notable at Pella.

As noted above, in the agora at Pella there are foundations of long stoas on the east and north forming a rectangle with wells in many of the shop

⁴²⁴ For instance, itinerant craftsmen have been posited as a possible reason for some Athenian details seen in the temple of Hera at the Argive Heraion (Pfaff 2004).

⁴²⁵ See Lilimpaki-Akamati and Akamatis, et al. 2011, 72. The date is made based on finds from construction fill and by the latest burials in the cemetery directly beneath the agora (ibid.).

rooms of the eastern building complex, making it comparable to the South Stoa at Corinth. The stoa at Pella is composed of small ashlar block foundations, supporting plastered mudbrick walls, and thus lacks the monumentality of the South Stoa at Corinth; The function of the eastern block of rooms has been tied to commercial activities and at least the northern block was two storied based on the preservation of a staircase.⁴²⁶

Pending final publication of this building, drawing parallels might be misleading, but a connection to Macedonian buildings in the late 4th or early 3rd centuries is tantalizing given the expansion of Demetrios into the Peloponnesos at exactly this time. Debris found on the floors inside the rooms of the stoa at Pella has led to the proposal that the stoa rooms served as pottery workshops. It is unclear exactly what purpose the wells served in this capacity, but one might surmise the necessity of water for such activities as burnishing and painting pottery among other things. No kilns have been published in connection with the complex, however. The correspondence between the eastern stoa complex at Pella with wells in many of the rooms and the South Stoa at Corinth with a similar arrangement might suggest a similar function for the rooms in the South Stoa, but the material in the rooms is otherwise lacking to substantiate the parallel. The relationship of a Macedonian architectural tradition of an agora bordered by extensive colonnades, with shops behind, to the wider practice of Greek stoa design in the Hellenistic period would have manifested itself through the political and social interaction between the Macedonians and the rest Greek world

⁴²⁶ Lilimpaki-Akamati and Akamatis, et al. 2011, 67.

beginning in the late 4th century B.C. and continuing through the Hellenistic period.

What is certain is that at the end of the 4th century B.C. the splintering of Macedonian power led to widespread infusion of Macedonian money and support for city-states around the Mediterranean. Some, like Pergamon or Miletos, saw urban development on a grand scale in the Hellenistic period. Based on the evidence from Pella, the beginnings of large scale stoa architecture and multi-storey palatial style buildings may then have occurred in Macedonia territory before spreading around the mediterranean. The palaces and the buildings on the agora, with a date in the late 4th century B.C., indicate that both of these architectural models perhaps saw their flowering in Macedonia before spreading throughout the Greek world. That the Macedonians were borrowing and expanding on earlier Greek architectural traditions is without question, but the impetus to develop architecturally on such a monumental scale may have come from the political leadership of the Macedonian dynasties. The South Stoa might then be a part of this new urban monumental planning as one of the earliest buildings showcasing that monumentality in the emerging Hellenistic period.

The length of the South Stoa corresponds with the distance from the north stylobate of the Archaic temple to the stylobate of the South Stoa. It is tempting to think that the construction of the stoa may have been initially planned so that matching colonnades would run perpendicular from the two ends of the stoa toward Temple Hill enclosing the open area that included the dromos. If this were true it would have created an enclosed space similar to the agora at Pella. This would not necessarily mean, however, that the open

area in front of the South Stoa at Corinth must be the agora by this period. On a less grand scale the sanctuary of Artemis at Brauron, ca. 420-415 B.C., with its Π-shaped stoa framed on the fourth side by the terrace for the temple had already achieved such a space in a sanctuary. There is no solid evidence, however, that anything like this was done in the Greek or Hellenistic periods at Corinth. In the Roman period, this arrangement was facilitated in an abbreviated fashion. Two colonnades ran perpendicular from both ends of the stoa north to the central shops, creating an enclosed terrace.

I would argue that at Corinth it is possible to see the beginnings of Macedonian influence in the South Stoa, with its large footprint on the urban landscape of the city. While the evidence is not conclusive, the stoa and its peculiar design may be a statement of Macedonian interest in the region, although this can only be posited as a tentative possibility. If so, historical circumstances caused this purpose to be short lived and local economic and civic factors would have determined a different purpose or purposes for the building. In any event, the construction and function of the South Stoa is more safely grounded in the multifunctional aspect to which stoas were put throughout the Greek world. If the South Stoa rooms functioned as commercial shops at some point in the life of the building prior to the Roman period then perhaps the area had been turned over to an agora with the construction of the stoa or shortly thereafter. This is a question that cannot, as I see it, at the moment be solved on the weight of the current evidence; nor does it mean that there is not another space at Corinth which might be excavated and identified as an agora in the Greek period of the city.

This study has attempted to clarify several of the details of construction and design in the South Stoa based on a new analysis of the evidence. The South Stoa, constructed in local traditional limestone, was elaborately appointed to be a sumptuous and monumental stoa following the latest architectural trends at the end of the 4th century B.C. in Greece. The design of the stoa followed late 4th century temple design in concept and form, though the execution of the design was fundamentally influenced by the particular demands of the stoa in terms of length, height and the addition of the back rooms. What the initial function of the South Stoa was cannot be ascertained with certainty from the evidence gathered in the excavations of the building and its wells, nor from the design of the building, but a re-examination of the evidence allows for some measured speculation. As a stoa, its function was probably already multifarious in its long history well before Roman interventions altered the rooms at the back drastically into something else again. That the rooms in the initial Greek phase of the building could have served for dining is possible, though no certain arrangement of couches within the rooms is possible and more temporary arrangements may have been intended from the start. That the stoa and its rooms may have been built in part to serve as a place for meetings of the re-founded league under the Antigonids is also possible, though not certain and no parallels exist for such a building. If one is to see the South Stoa serving as an official meeting place, it may be that at times when city officials needed to meet, it was used for this purpose, while the rest of the time the rooms were probably used for commercial purposes, or any other purpose for which a stoa could be put. That it could also have been used by athletes training for the Isthmian games,

as well as officials for the games, is also possible, but we should probably not see the length of the stoa as indicating a *xystos* for indoor running. The building is too luxurious. The wells do not solve the question of function and the parallel of the shop wells at Pella, along with the evidence of the manufacture and selling of pottery there, is only suggestive of one possible activity for the rooms of the South Stoa, which otherwise did not preserve material indicating this kind of workshop activity. The number of wells in the rooms of the South Stoa would seem to suggest industrial activity or large gatherings of people and it is hard to see so many rooms being used for anything other than shops for most of the Greek phase of the building.

In terms of where the South Stoa fits in the development of civic architecture it is now possible to say that it along with the stoa at Megalopolis, the stoas in the agora at Pella and shortly thereafter at Thermon, mark a new period of large scale urban planning. Architects utilized the stoa concept for its elasticity in terms of length and height, influenced by and in some cases in response to Macedonian expansion, while in details largely following local or regional design.

Appendix: Vitruvius and Building Types

Vitruvius' discussion of building types includes a reference to Greek palastras, which he describes as square or oblong peristyles having a perimeter measuring two stades (equal to the Greek "diaulos"). Three sides were single colonnades, while the fourth should face south and be double (5.11.1-4).

Vitruvius also mentions the *xystos*, which is the Greek term for a covered portico with the length of a stadion, where athletes could train in inclement weather. Next to the *xystos*, Vitruvius places twin porticos on either side with open air promenades called "paradromides" (5.11.4).

The attempt by Vitruvius to distinguish palastras from gymnasia and *xystoi* is not so easily deduced from evidence in the Greek world. The unifying features of all these building types are that they have colonnades arranged for the benefit of athletic training.

When Vitruvius moves on to other types of colonnaded buildings, he distinguishes their function as commercial. For Vitruvius, the Greek "forum" "was very spacious with double porticos" (5 1.1), "having money changers' shops and balconies on the upper storeys for viewers' convenience and for revenue" (5.1.2). Vitruvius' discussion is probably based on Hellenistic models of stoas lining the edges of Greek agoras, many of which would still have been visible in his day, and his attention to balconies implies that he was familiar with multi-leveled varieties of stoas. The main distinction that can be drawn from his discussion is one of function between stoas related to athletic activities and stoas dedicated to commercial purposes, both of which might coexist within the city space.

Vitruvius' separate categories of peristyle colonnades imply that they are distinct design categories as well, which is not necessarily the case in practice. In fact he discusses them within a broader category, separate from temple design, of colonnaded buildings having different functions. The point is that the differences in function of peristyles and colonnades do not detract from the relationships that the buildings share in terms of design. This might seem like an obvious conclusion, but rarely is design looked at from the points of comparison between building types. While it is important to distinguish between types of buildings, it should be equally important to look at their shared characteristics and, in fact, to draw out these characteristics. Just as stoas would have drawn from temples and propylaia, the influence of palaistras and gymnasia on stoa design and vice versa should not be underestimated.

Bibliography

- Amandry, P. 1981. "Chronique delphique (1970-1981)." *BCH* 105: 673-769.
- 1983. "Delphes." *BCH* 107: 854-861.
- Bankel, H. 1983. "Zum Fussmass attischer Bauten des 5. Jahrhunderts v. Chr.," *AM* 98: 65-99.
- 1993. *Der spätarchaische Tempel der Aphaia auf Aegina* (DAA 19), Berlin.
- Bohn, R. 1885. *Altertümer von Pergamon II, das Heiligtum der Athena Polias Nikephoros*, mit einem Beiträge von Hans Droysen. Berlin.
- Bookidis, N. and R. Stroud. 1997. *The sanctuary of Demeter and Kore, topography and architecture*, Princeton.
- Bouras, Ch. 1967. Η αναστήλωση της στοάς της Βραυρώνος : τα αρχιτεκτονικά προβλήματα. Υπουργείο Πολιτισμού - Γενική Διεύθυνση Αρχαιοτήτων και Αναστηλώσεως. Athens.
- Bousquet, J. 1984. "Inscriptions de Delphes. A) Les sculptures tympanales du temple delphique d'Apollon (IVe s.) et les comtes des trésoriers." *BCH* 108: 695-698.
- 1989. *Les comtes du quatrième et du troisième siècle (Corpus des inscriptions de Delphes II)*, Paris.
- Broneer, O. 1933. "Excavations in the agora at Corinth, 1933." *AJA* 37: 554-72.
- 1935. "Excavations in Corinth, 1934." *AJA* 39, 1: 53-75.
- 1947. "Investigations at Corinth, 1946-47." *Hesperia* 16: 233-47.
- 1949. "Measurements and refinements at the South Stoa at Corinth." *AJA* 53, 2: 146-147.

- , 1950. "Investigations at Corinth." *Hesperia* 20: 291-300.
- , 1954. *The South Stoa and its Roman Successors, Corinth I, iv*, Princeton.
- , 1971. *Temple of Poseidon. Vol. I. Isthmia Excavations*. Princeton.
- Burford, A. 1969. *The Greek Temple Builders at Epidauros*. Liverpool.
- Charbonneau, J. and K. Gottlob. 1925. *La Tholos (FdD II: Topographie et architecture, Le Sanctuaire d'Athéna Pronaia 2)*, Paris.
- Clarke, J.T., F.H Bacon and R. Koldewey. 1902-21. *Investigations at Assos, drawings and photographs of the buildings and objects discovered during the excavations of 1881-1883*, edited by F.H. Bacon. Cambridge, MA.
- Conze, A., A. Hauser, O. Benndorf. 1880. *Neue Untersuchungen auf Samothrake II*. Wien.
- Cooper, F. 1996. *The Temple of Apollo Bassitas I. The Architecture*. Princeton.
- Coulton, J. J. 1964. "The stoa by the harbour at Perachora." *BSA* 59: 100-131.
- , 1966. "The treatment of re-entrant angles." *BSA* 61: 132-146.
- , 1967. "A tympanum fragment at Perachora." *BSA* 62: 207-210.
- , 1968. "The Stoa of the Amphiarraion at Oropos." *BSA* 63: 147-183.
- , 1971. "Διπλή Στοά." *AJA* 75: 183-4.
- , 1973. "The columns and roof of the south stoa at the Argive Heraion." *BSA* 68: 65-85.
- , 1974a. "Lifting in early Greek architecture." *BSA* 94: 1-19.
- , 1974b. "Towards understanding Doric design: The stylobate and intercolumniations." *BSA* 69: 61-86.

- , 1975. "The second temple of Hera at Paestum and the pronaos problem." *JHS* 95: 13-24.
- , 1975. "Towards understanding Greek temple design. General considerations." *BSA* 70: 59-99.
- , 1976. *The architectural development of the Greek stoa*. Oxford.
- , 1979. "Doric capitals. a proportional analysis." *BSA* 74: 81-153.
- , 1979. "Extended angle intercolumniations in fifth-century Athenian Ionic." *JHS* 99: 155-7.
- , 1980. "Hellenistic royal architecture." *PCA* 77: 21-22.
- , 1982. *Ancient Greek architects at work: problems of structure and design*, Ithaca, New York.
- , 1985. "Incomplete preliminary planning in Greek architecture. Some new evidence." *Le dessin d'architecture dans les sociétés antiques. Actes du colloque de Strasbourg, 26-28 janvier 1984*, Leiden, 103-121.
- , 1989. "Modules and measurements in ancient design and modern scholarship." *Munus non ingratum: proceedings of the international symposium on Vitruvius' De Architectura and the Hellenistic and Republican architecture, Leiden 20-23 January 1987*, Leiden.
- Courby, M. 1927. *La terrasse du temple*, (*FdD* II : Topographie et architecture, Le Sanctuaire d'Apollon 2), Paris.
- Courby, F. and C. Picard. 1924. *Recherches archéologiques à Stratos d'Acarnanie*, Paris.
- Dekoulakou-Sideris, I. 1990. "A metrological relief from Salamis." *AJA* 94: 445-51.
- Dinsmoor, W. B. 1950. *The architecture of ancient Greece*. London – New

York.

-----, 1961. "The basis of Greek temple design in Asia Minor, Greece, Italy," *Atti VII Congresso internazionale di archeologia classica I, Rome*. 358-61.

----- and W. B. Dinsmoor, Jr. 2004. *The Propylaia to the Athenian Akropolis II: The Classical Building*. Edited by A. N. Dinsmoor. Princeton.

Dörpfeld, W. 1890. "Metrologische Beiträge," *AM* 15: 176-77.

Edwards, G. R. 1975. *Corinth*, Vol. VII.iii. *Corinthian Hellenistic pottery*. Princeton.

Fowler, H. and R. Stillwell. 1932. *Corinth I.i, Introduction, Topography, Architecture*. Princeton.

Freyberg, B. von. 1973. "Geologie des Isthmus von Korinth," *Erlanger geologische Abhandlungen* 95.

Gerkan, A. v. 1922. *Milet* 1.6, Berlin.

Glass, S. 1967. *Palaistra and gymnasium in Greek architecture*. University of Pennsylvania Diss.. University Microfilms, Inc. Ann Arbor, Michigan.

Gruben, G. 1976. "Die Tempel der Griechen." Munich.

Guarducci, M. 1974. *Epigrafia Greca III*. Roma.

Hammond, N. G. L., and F. W. Walbank. 1988. *A history of Macedonia. Volume III. 336-167 B.C.* Oxford.

Hansen, E. 2000. "Delphes et le travail de la pierre." *BCH Suppl.* 36: 201-233.

Hansen, E., ed. 1991. "Versetzen von Baugliedern am Griechischen Tempel." *Bautechnik der Antike, Internationales Kolloquium in Berlin vom 15.-17.*

Februar 1990 veranstaltet vom Architekturreferat des DAI in Zusammenarbeit mit dem Seminar für Klassische Archäologie der Freien Universität Berlin,

Mainz am Rhein, 72-79.

- Haselberger, L. and H. Seybold. 1991. "Seilkurve oder Ellipse? Zur Herstellung antiker Kurvaturen nach dem Zeugnis der didymeischen Kurvenkonstruktion," *AA*, 165-188.
- Haselberger, L., ed. 1999. *Appearance and essence. Refinements of classical architecture: curvature*. University Museum Monograph 107, Symposium Series 10, Philadelphia.
- Hayward, C. 2003. "Geology of Corinth: The study of a basic resource." *Corinth*, Vol. 20, *Corinth, The Centenary: 1896-1996*, Princeton, pp.15-42.
- Hayward, C. "High resolution provenance determination of construction stone. A Preliminary Study of Corinthian Oolitic Limestone Quarries at Examilia." *Geoarchaeology*, John Wiley and Sons Ltd.
- Heermance, T. W. 1904. "Excavations at Corinth in 1904: Preliminary report." *AJA* 8: 433-441.
- Heermann, V. 1986. *Studien zur makedonischen Palastarchitektur*. Diss. Friedrich Alexander Universität, Erlangen-Nürnberg.
- Hill, B. H., and C. K. Williams II. 1966. *The Temple of Zeus at Nemea*. Princeton.
- Hellstrom, P. 2007. *Labraunda, a guide to the Karian sanctuary of Zeus Labraundos*, Istanbul.
- Hoepfner, W. 1999. *Geschichte des Wohnens. Band I. 5000 v.- Chr. 500 n. Chr. Vorgeschichte Frühgeschichte Antike*. Stuttgart.
- Hoepfner, W. und G. Brands. 1996. *Basilea, Die Paläste der Hellenistischen Könige. Internationales Symposium in Berlin vom 16. 12. 1992 bis 20. 12. 1992*. Mainz am Rhein.

- Hoepfner, W., E.-L. S. 1990. *Hermogenes und die hochhellenistische Architektur*. Internationale Kolloquium in Berlin von 28. bis 29. Juli 1988, Berlin, Mainz am Rhein.
- , 1988. "Proportionen klassischer Ionischer kapitelle," in Büsing and Hiller, *Bathron: Beiträge zur Architektur und verwandten Künsten für Heinrich Drerup zu seinem 80. Geburtstag von seinem Schülern und Freunden* (Saarbrücker Studien zur Archäologie und alten Geschichte 3), Saarbrücken.
- Hodge, T. 1960. *The Woodwork of Greek Roofs*. Cambridge.
- Jacopi, G. 1933. *Clara Rhodos* 6-7:1 [1932-3], Bergamo, 241-9.
- Kanellopoulos, C. 2003. "Building Phases of the Acropolis of Ancient Karthaia." *AM* 118: 211-238.
- Kaweran, G. and A. Rehm. 1914. *Milet I, 3 : Das Delphinion in Milet*. Berlin.
- Kent, J. H. 1952. "The Victory Monument of Timoleon at Corinth", *Hesperia* 21: 9-18.
- Knackfuss, H. 1924. *Milet* 1.7, Berlin.
- Koenigs, W. 1979. Zum Entwurf dorischer Hallen, " *IstMitt* 29: 209-237.
- Kohte, J. 1904. *Magnesia am Meander*. Berlin.
- Korres, M. 1994. "The Architecture of the Parthenon", in *The Parthenon and its Impact in Modern Times*. Ed. P. Tournikiotis. Athens.
- Lauter, H. 1986. *Die Architektur des Hellenismus*. Darmstadt: Wissenschaftliche Buchgesellschaft.
- Lawrence, A. W. 1996. *Greek Architecture*. New Haven.
- Leybold C. 2008. *Bankettgebäude in griechischen Heiligtümern*. Reichert Verlag Wiesbaden.

- Lilimpaki-Akamati, M., 1996. *Pella, Capital of Macedonians*. Ministry of Culture Archaeological Receipts Fund. Athens.
- Lilimpaki-Akamati, M. and Ioannis Akamatis, et al. 2011. *The archaeological museum of Pella*. John S. Latsis, Public Benefit Foundation. Athens.
- Lilimpaki-Akamati, M. and I. Akamatis. 2003. *Pella and its environs*. Thessaloniki.
- Llinas, C. 1965. "Le portique coudé de Pérachora." *BCH* 89: 484-97.
- Lorenzen, E. 1964. *The Arsenal at Piraeus*. Copenhagen.
- Mallwitz, A. 1972. *Olympia und seine Bauten*. Darmstadt.
- Martin, R. 1959. *Thasos, 1959. L'Agora, I*. Paris.
- Martin, R. 1965. *Manual d'architecture grecque*. Paris.
- Mertens, D. 2006. *Städte und Bauten der Westgriechen: von der Kolonisationszeit bis zur Krise um 400 vor Christus*. Munich.
- Michaud, J.-P. 1977. *Le temple en calcaire (FdD II: Topographie et architecture, Le Sanctuaire d' Athéna Pronaia 4)*, Paris.
- Miller, S. G. 1974. *Hellenistic Macedonian architecture*, Bryn Mawr College. Ph.D. diss.
- Miller S. G. 1978. *The Prytaneion: its form and function*. Berkeley.
- Morgan, C. H. 1953. "Investigations at Corinth, 1953 – a tavern of Aphrodite." *Hesperia* 22: 131-140.
- 1939. "Investigations at Corinth, 1938." *AJA* 43: 258.
- 1938. "Excavations at Corinth, Autumn 1937." *AJA* 42: 362-70.
- 1937. "Excavations at Corinth, 1936-1937." *AJA* 41: 539-52.
- 1936. "Excavations at Corinth, 1935-1936." *AJA* 40: 466-484.
- Nielson, I. 1994. *Hellenistic palaces. Tradition and renewal*. Aarhus.

- Orlandos, A. K. 1955-1958. "Τὰ ὑλικά δομῆς τῶν ἀρχαίων Ἑλλήνων"
(Βιβλιοθήκη τῆς ἐν Ἀθήναις Ἀρχαιολογικῆς Ἐταιρείας 37), 2 vols., Athens.
- . 1962. *Το Ἔργον τῆς ἀρχαιολογικῆς ἐταιρείας κατὰ τὸ 1961*. Athens.
- Osborne, R. 2004. "Greek Archaeology: a survey of recent work." *AJA* 108:
87-102.
- Pakkanen, J. 1997. "Entasis in fourth-century BC Doric buildings," *BSA* 92:
321-344.
- . 1998. *The Temple of Athena Alea at Tegea: A reconstruction of the
peristyle column* (Publications by the department of Art History at the
University of Helsinki 18), Helsinki.
- . 2006. "The Erechtheion construction work inventory", *AJA* 110: 275-281.
- Parsons, A. W. 1936. "The long walls to the gulf," in R. Carpenter and A. Bon.
Corinth III, 2. The Defences of Acrocorinth and the lower town. Cambridge MA.
107-23.
- Paton, J. M. and G. P. Stevens. 1927. *The Erechtheum*, Cambridge, MA.
- Penrose, F. C. 1902. "On the origin and construction of the Ionic volute,"
JRIBA, series III, X₂, 19-30.
- Pfaff, C. A. 1999. "Curvature in the temple of Apollo at Corinth and in the
South Stoa and classical temple of Hera at the Argive Heraion," in
*Appearance and essence: refinements of classical architecture, curvature:
Proceedings of the second Williams symposium on classical architecture at
the University of Pennsylvania, Philadelphia, April 2-4, 1993* (University
Museum Monograph 107, Symposium Series 10), L. Haselberger, ed.,
Philadelphia, 113-125.
- . 2001a. "A re-evaluation of the roof of the South Stoa at the Argive

- Heraion." *BSA* 96: 261-279.
- , 2001b. "Fifth-century contractors' marks at the Argive Heraion." *JHS* 121: 150-153.
- , 2003. *The architecture of the classical temple of Hera*. Princeton.
- Plommer, H. 1970. "Vitruvian studies." *BSA* 65: 179-190.
- Richardson, R. B. 1897. "The excavations at Corinth in 1896." *AJA*, 1: 455-480.
- Robertson, D. S. 1943. *Greek and Roman Architecture*.
- Roebuck, C. 1951. *The Asklepieion and Lerna. Corinth XIV*, Princeton.
- Roebuck, M. 1994. "Architectural terracottas from Classical and Hellenistic Corinth", in *Proceedings of the international conference on Greek architectural terracottas of the Classical and Hellenistic periods, Hesperia Suppl. 27*. N. Winter, ed., Princeton. 39-51.
- Romano, D. G. 1981. *The Stadia of the Peloponnesos*. Ph.D. diss., University of Pennsylvania, University Microfilms, Inc. Ann Arbor, Michigan.
- , 1985. "The Panathenaic Stadium and Theater of Lykourgos: a re-examination of the facilities on the Pnyx Hill," *AJA* 89: 441-454.
- , 1993. *Athletics and mathematics in Archaic Corinth. The origins of the Greek stadion*. American Philosophical Society. Philadelphia.
- , Rotroff, S. and J. Oakley. 1992. "Debris from a public dining place in the Athenian Agora." *Hesperia Suppl. 25*. Princeton.
- Roux, G. 1961. *L' Architecture de l'Argolide aux IV^e et III^e siècles avant J. C.* (*BEFAR 199*), Paris.
- Salviat, F. 1962. "Addenda Samothraciens." *BCH* 86: 268-394.
- Schweigert, E. 1940. "Greek Inscriptions." *Hesperia* 9: 309-357.

- Scranton, R. 1951. *Corinth, 1.3. Monuments in the lower agora and north of the Archaic temple*. Princeton.
- Seddon, L. R. 1987. *The agora stoas at Assos, Aigai and Termessos: Examples of political function of Attalid architectural patronage*. Diss. UCLA. University Microfilms, Inc. Ann Arbor.
- Shear, T. L. 1971. "The Athenian Agora: Excavations of 1970." *Hesperia* 40: 243-255.
- Shoe, L. T. 1936. *Profiles of Greek mouldings*, Cambridge, MA.
- 1996. "Athenian Ionic capitals from the Athenian Agora". *Hesperia* 65: 121-174.
- Stieglitz, R. 2006. "Classical Greek measures and the builder's instruments from the Ma 'agan Mikhael shipwreck." *AJA* 110: 195-203.
- Stillwell, R., R. Scranton, et. al. 1941. *Corinth, I.2. Architecture*. Princeton.
- Stillwell, R. 1952. *Corinth, 2. The Theatre*. Princeton.
- 1936. "Excavations at Corinth, 1934-1935." *AJA* 40: 21-45.
- Talbert, R. J. A. 1974. *Timoleon and the revival of Greek Sicily*. New York.
- Tanoulas, T. 1997. *Τα Προπύλαια της Αθηναϊκής Ακρόπολης κατά τον Μεσαίωνα*. Βιβλιοθήκη της εν Αθήναις Αρχαιολογικής Εταιρείας Αρ. 165, Athens.
- Thompson, H. and R. L. Scranton. 1943. "Stoas and city walls on the Pnyx." *Hesperia* 12: 269-383.
- Thompson, H. A., 1954. "Excavations in the Athenian Agora: 1953." *Hesperia* 23: 39-45.
- Thompson, H. A. 1968. "Activity in the Athenian Agora: 1966-1967." *Hesperia* 37: 46-8.

Thompson, H. A. 1972. *Agora 14. The history, shape and uses of an ancient city center*. Princeton.

Tomlinson, R. A. 1992. Review: *Hermogenes und die hochhellenistische Architektur. Internationale Kolloquium in Berlin von 28. bis 29. Juli 1988* by W. Hoepfner; E.-L. Schwandner, *The Classical Review*, New Ser. Vol. 42, No. 1, 147-148.

Tomlinson, R. A. 1969. "Perachora: the remains outside the two sanctuaries." *BSA* 64: 155-258.

Townsend, R. F. 2004. "Classical signs and anti-classical signification in 4th-century Athenian architecture," *XAPIΣ, Essays in Honor of Sara A. Immerwahr, Hesperia Suppl.* 33, 305-326.

----- . 1982. *Aspects of Athenian Architectural Activity in the Second Half of the Fourth Century B.C.* Diss. UMI, Ann Arbor.

Travlos, J. 1971. *Pictorial Dictionary of Ancient Athens*. London.

Travlos, J. 1988. *Bildlexikon zur Topographie des antiken Attika*. Tübingen.

Ulrich R. B. 1996. "Contignatio, Vitruvius, and the Campanian builder," *AJA* 100: 137-151.

Vallet G., F. Villard. 1966. *Megara Hyblaea 4. Le temple du IV^e siècle*. Paris.

Vallois, R. 1944. *L'architecture hellénique et hellénistique à Délos ii*. Paris.

Waele, F. J. de. 1931. "The Greek stoa north of the temple at Corinth," *AJA* 35, 399-423.

Waele, J. A. K. E. de. 1980. "Der Entwurf der dorischen tempel von Akragas," *AA*, 180-241.

----- . 1990. *The Propylaia of the Akropolis in Athens: The Project of Mnesikles*,

Amsterdam.

Weinberg, S. 1939. Excavations at Corinth, 1938-1939." *AJA* 43: 562-600.

Welles, C. B. 1947. "Archaeological news, Corinth." *AJA* 51, 3: 271-3.

Williams, C. K. II. 1995. "Archaic and Classical Corinth," in *Corinto e l'Occidente, (Atti del trentaquattresimo convegno di studi sulla Magna Grecia Taranto, 7-11 ottobre 1994)*, Taranto, 31-45.

----- . 1980. "Corinth Excavations, 1979." *Hesperia* 49: 107-134.

----- . 1979. "Corinth, 1978: Forum southwest." *Hesperia* 48: 125-136.

-----, J. L. Angel, P. Burns and J. E. Fisher. 1973. "Corinth, 1972: The Forum area." *Hesperia*, 42: 1-44.

----- . 1970. "Corinth, 1969: Forum area," *Hesperia* 39: 1-39.

----- and J. E. Fisher. 1972. "Corinth, 1971: Forum area." *Hesperia* 41: 143-184.

Wilson Jones, M. 2000a. *Principles of Roman architecture*. New Haven.

Wilson Jones, M. 2000b. "Doric measure and architectural design 1: The evidence of the relief from Salamis." *AJA* 104, 73-93.

Wilson Jones, M. 2001. "Doric measure and architectural design 2: A modular reading of the classical temple." *AJA* 105: 675-713.

Wilson Jones, M. 2002. "Tripods, triglyphs, and the origin of the Doric frieze." *AJA* 106: 353-390.

----- . 2006. "Ancient architecture and mathematics: Methodology and the Doric temple," in *Nexus VI: Architecture and mathematics*. Duvernoy, S. and Pedemonte, O., eds. Turin, 1-20.

Wiseman, J. 1972. "The gymnasium area at Corinth," 1969-1970." *Hesperia* 41: 1-42.

----- . 1978. *The Land of the Ancient Corinthians (Studies in Mediterranean Archaeology 50)*, Göteborg.

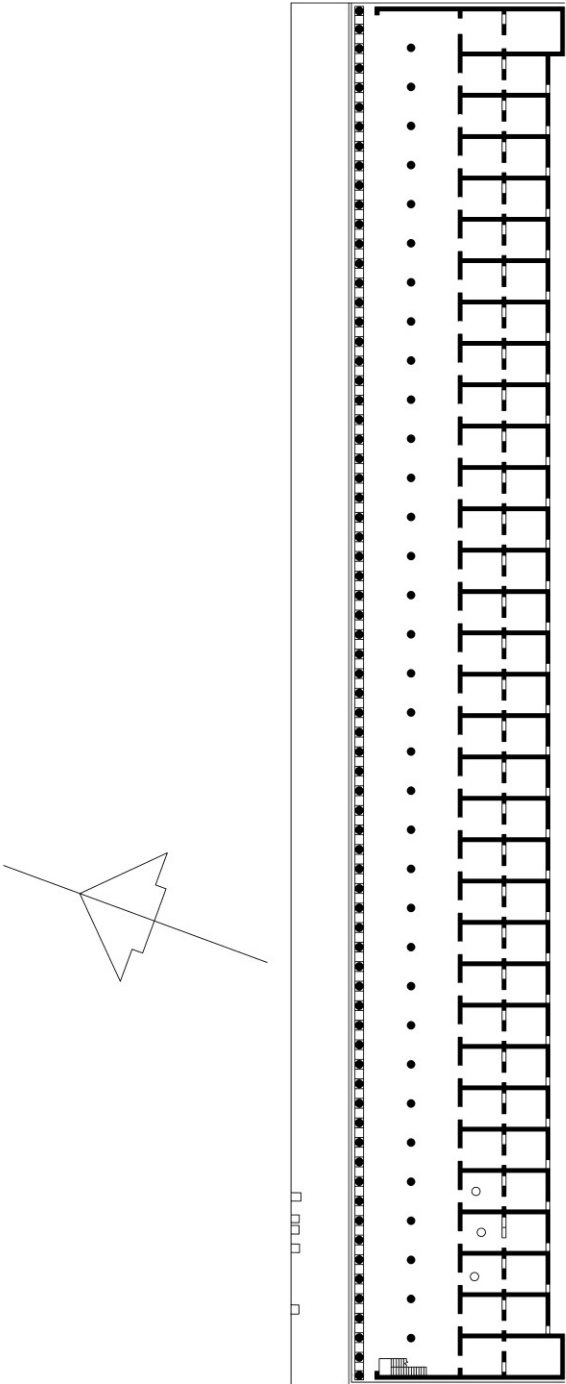

Plate 156. Plan of the South Stoa at Corinth, ca. 300 B.C.

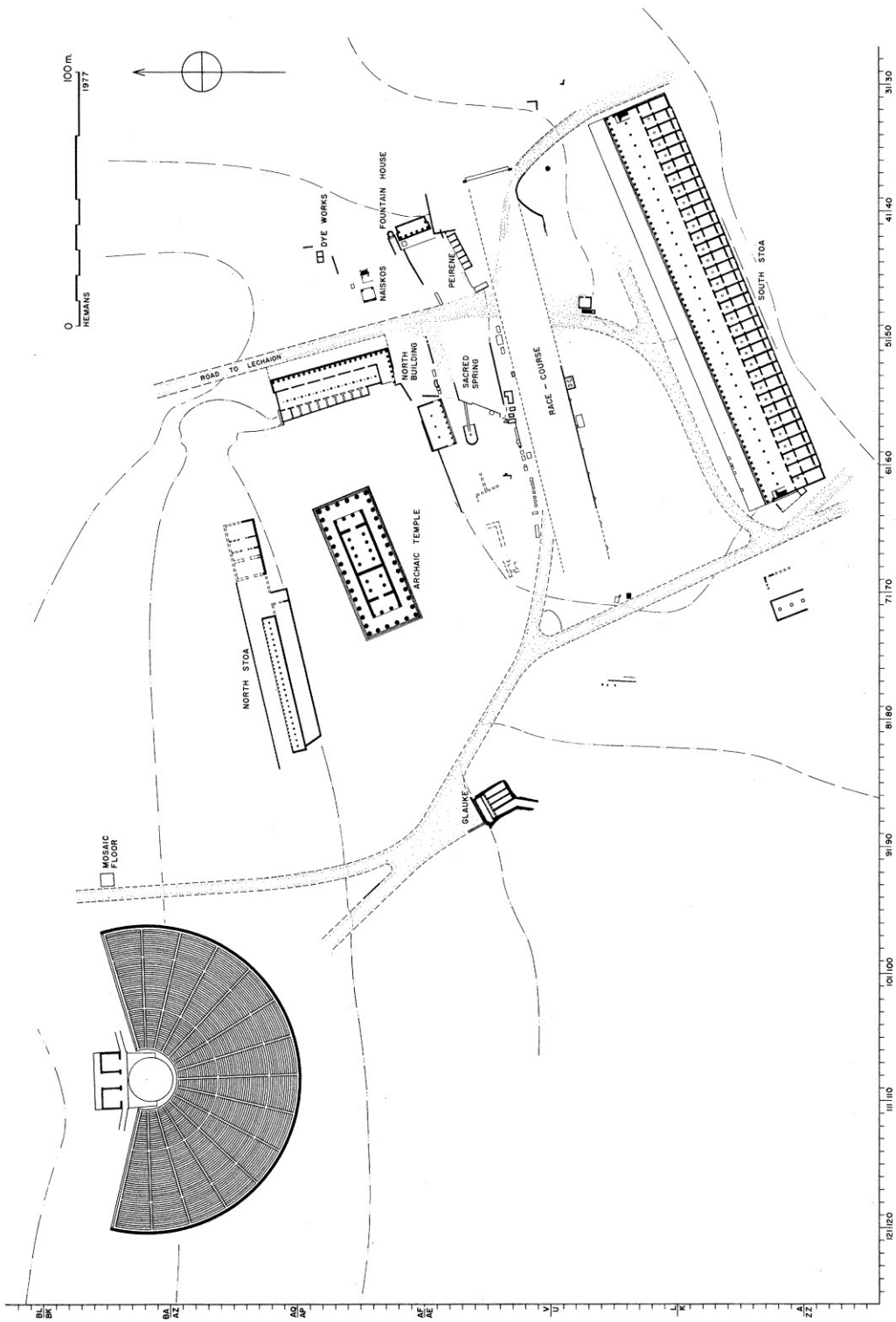

Plate 2. Plan of Corinth Central Area. Third Century B.C.

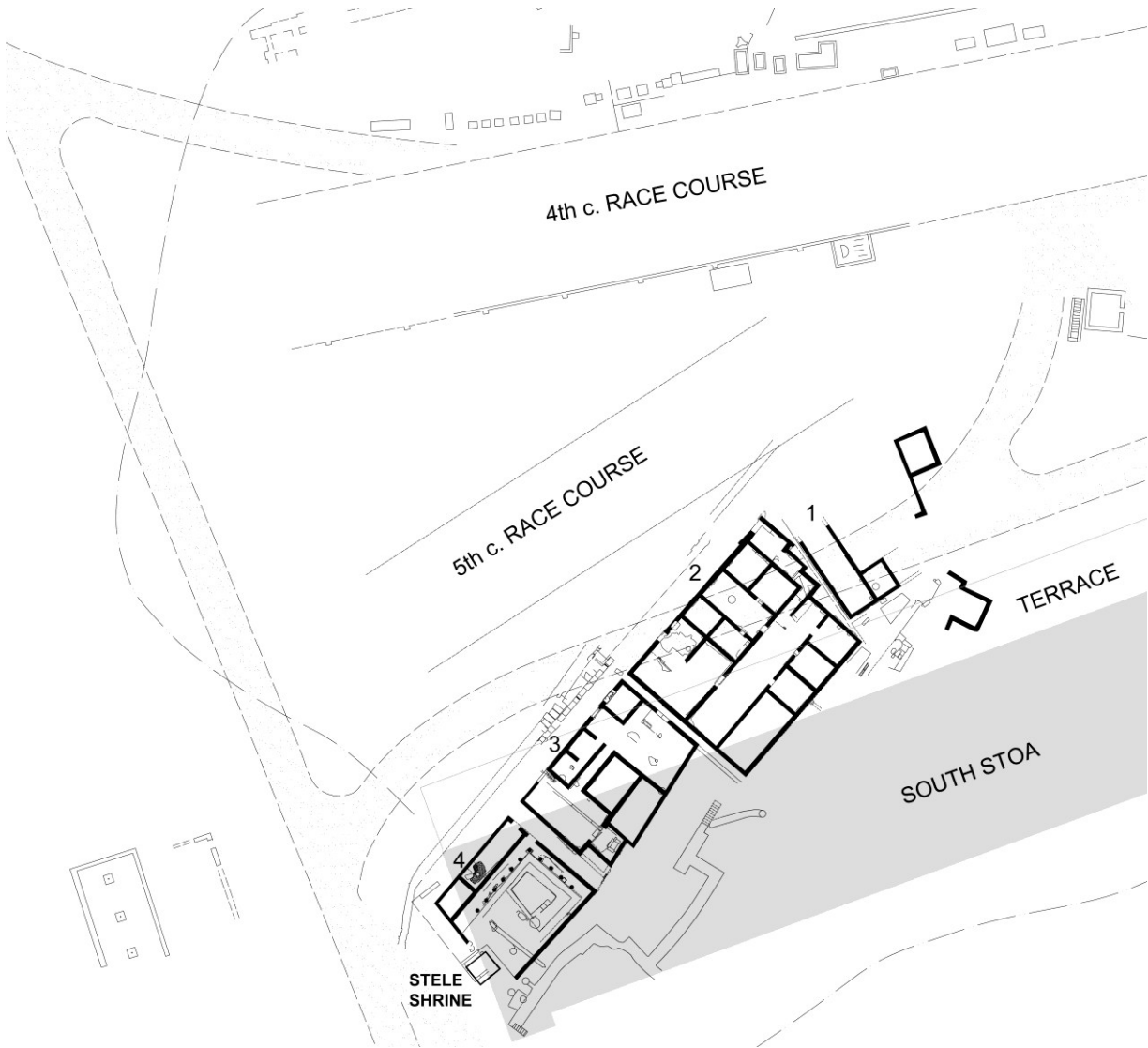
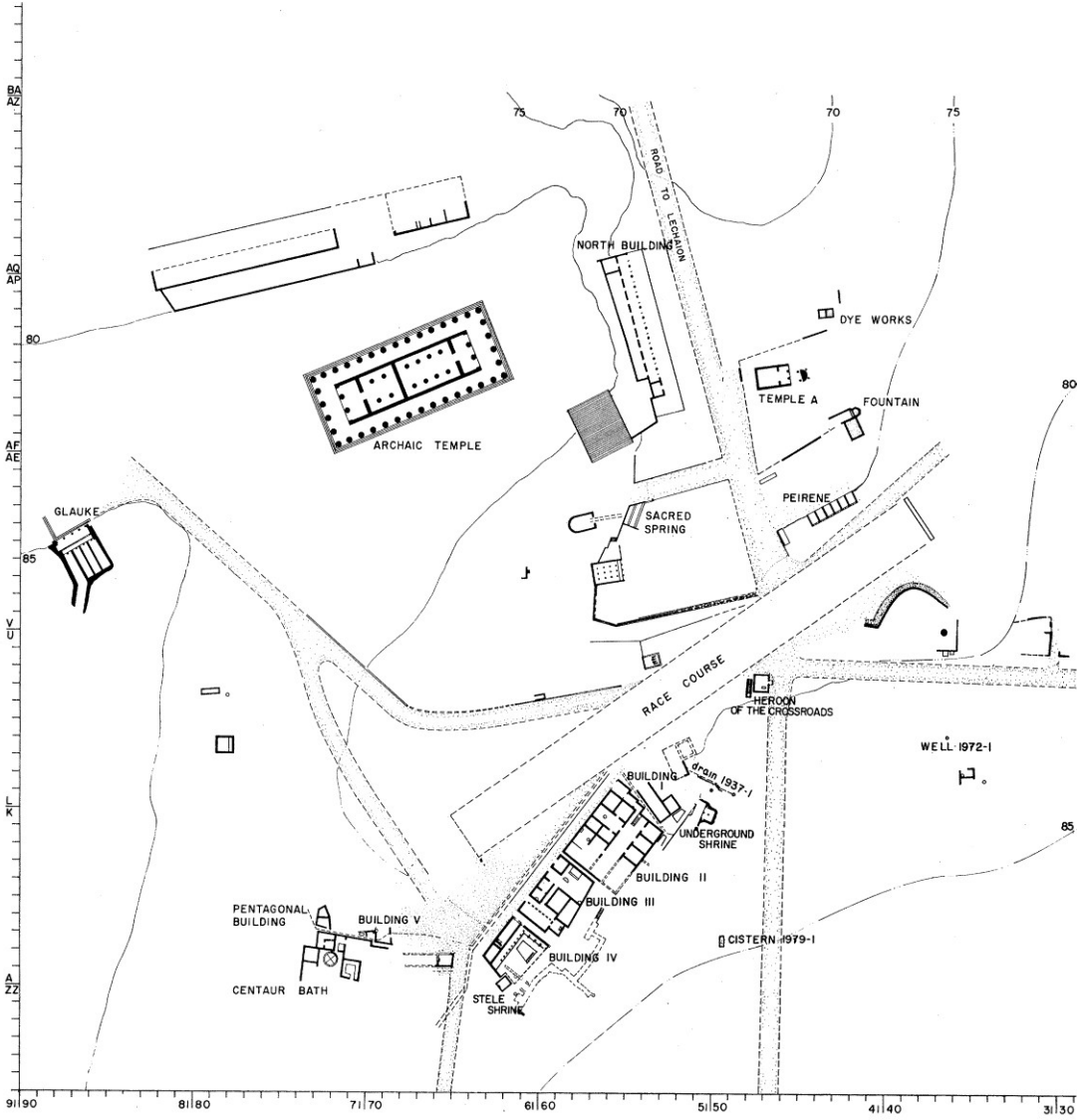

Plate 3. South side of central area with buildings and drain pre-dating the construction of the South Stoa and its terrace.



Plan. Corinth, Central Area, ca. 400 B.C.

Plate 4.