

ARCHAIC ARCHITECTURAL TERRACOTTAS FROM HALIEIS AND BASSAI

(PLATE 9)

HALIEIS

The Sanctuary of Apollo at Halieis now lies submerged in the bay of the modern town of Porto Cheli in the Argolid, where underwater excavations took place in 1970, 1971, and 1973.¹ Within the sanctuary are foundations for several buildings.² The two that concern us here are the Temple of Apollo, identified by inscription,³ and Building 2, first thought to be a Stoa, which I now identify as a second temple.

The two buildings stood side by side, with their outside walls less than one meter apart, and were in use during the same period. When the large quantities of terracotta revetment were analyzed, it became apparent that two nearly complete roof-tile systems could be reconstructed, and each could be assigned to the building for which it had been designed.⁴ The tiles were found in a layer covering the foundations with almost no mixing of the two types. Temple II had a Laconian-type roof (Fig. 1). The Temple of Apollo had a roof that I first called Corinthian type, to distinguish it from the Laconian roof (Fig. 2). Since a roof of such a design has not been found at Corinth, the term "Corinthian" should be avoided. I refer to it here as the "Halieis-style" roof.⁵

¹ The following abbreviation will be used in this article:

Yialouris, "Problems" = N. Yialouris, "Problems Relating to the Temple of Apollo Epikourios at Bassai," *Greece and Italy in the Classical World, Acta of the XI International Congress of Classical Archaeology, London, 3-9 September 1978*, London 1979, J. M. Coldstream and M. A. R. Colledge, edd. (pp. 89-104)

² For a site plan and plan of the Apollo sanctuary, see M. Jameson, "The Excavation of a Drowned Greek Temple," *Scientific American*, Oct. 1974 (pp. 111-119), pp. 113 and 114-115; *idem*, *Δελτ* 26, 1971 B' 1 (1974; pp. 114-119), p. 117, plan 1; *idem*, "Halieis at Porto Cheli," *Colston Papers*, 23, *Proceedings of the Twenty-third Symposium of the Colston Research Society Bristol 1971*, London 1973, pp. 219-229; *idem*, "Porto Cheli," *BCH* 89, 1966, pp. 787-791; *idem*, "Excavations at Halieis (Porto Cheli) 1973," *Δελτ* 29, 1973-1974, B' 2 (1979), pp. 261-268.

³ M. Jameson, "The Submerged Sanctuary of Apollo at Halieis in the Argolid of Greece," *The National Geographic Society Research Reports* 14, 1982 (pp. 363-367), p. 364.

⁴ Not all tiles from the Apollo Temple examined during excavation were inventoried. More than half of the tiles from the roof were recovered. The author's study (1977) of architectural terracottas from Halieis and a catalogue of the fragments will be published in the projected volume *Halieis, II, The Apollo Sanctuary, Architecture*, edited by Michael Jameson. See also N. Cooper, 1983. The author's work was supported by grants from the Minnesota Foundation, the American Philosophical Society: Penrose Fund 1979, and the University of Pennsylvania and Indiana University excavations.

⁵ See footnote 3 above. N. Winter has suggested "Argive-style" roof (pp. 13-32 above).

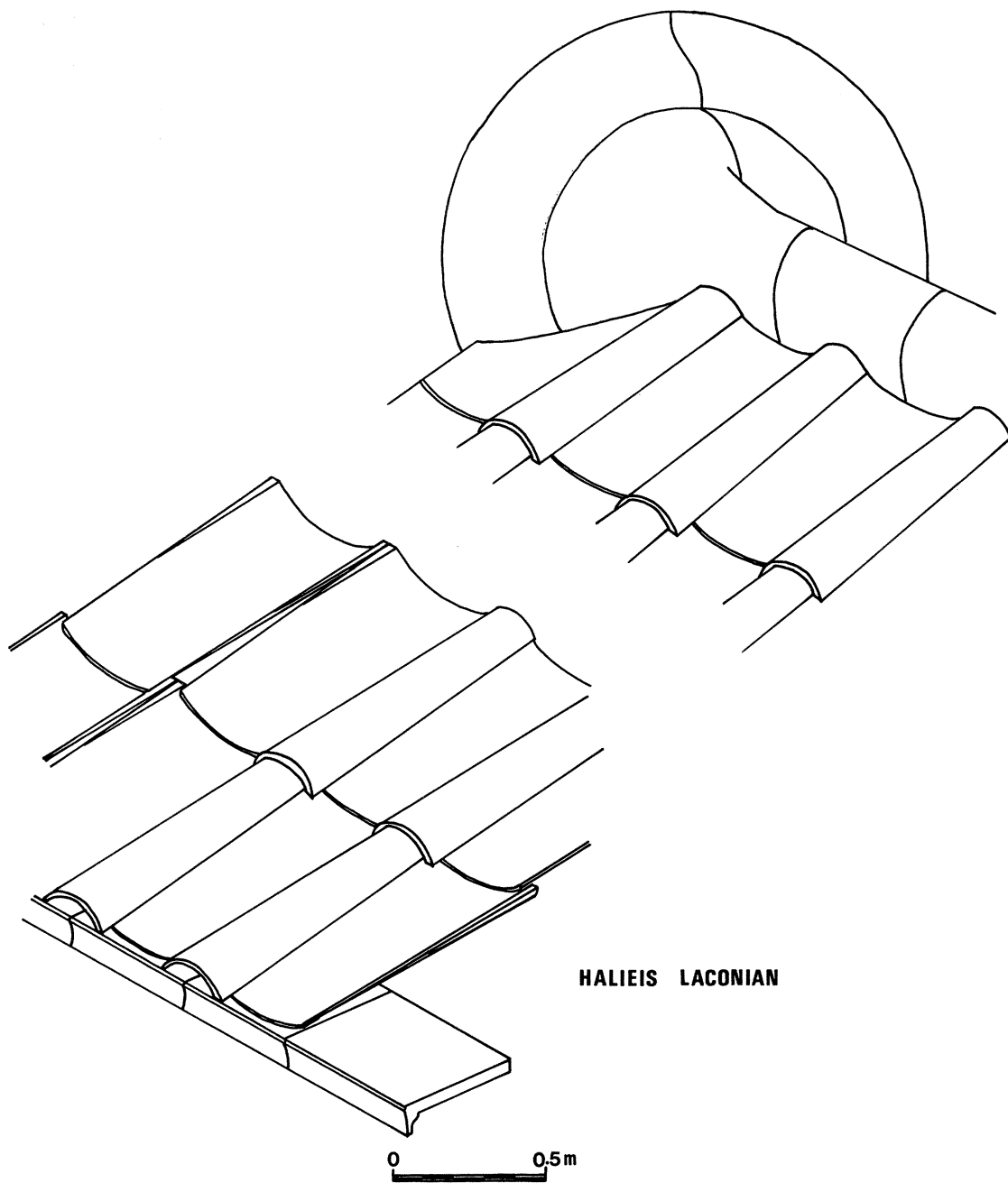

FIG. 1. Halieis, Laconian Roof, eaves and ridge, with back of disk

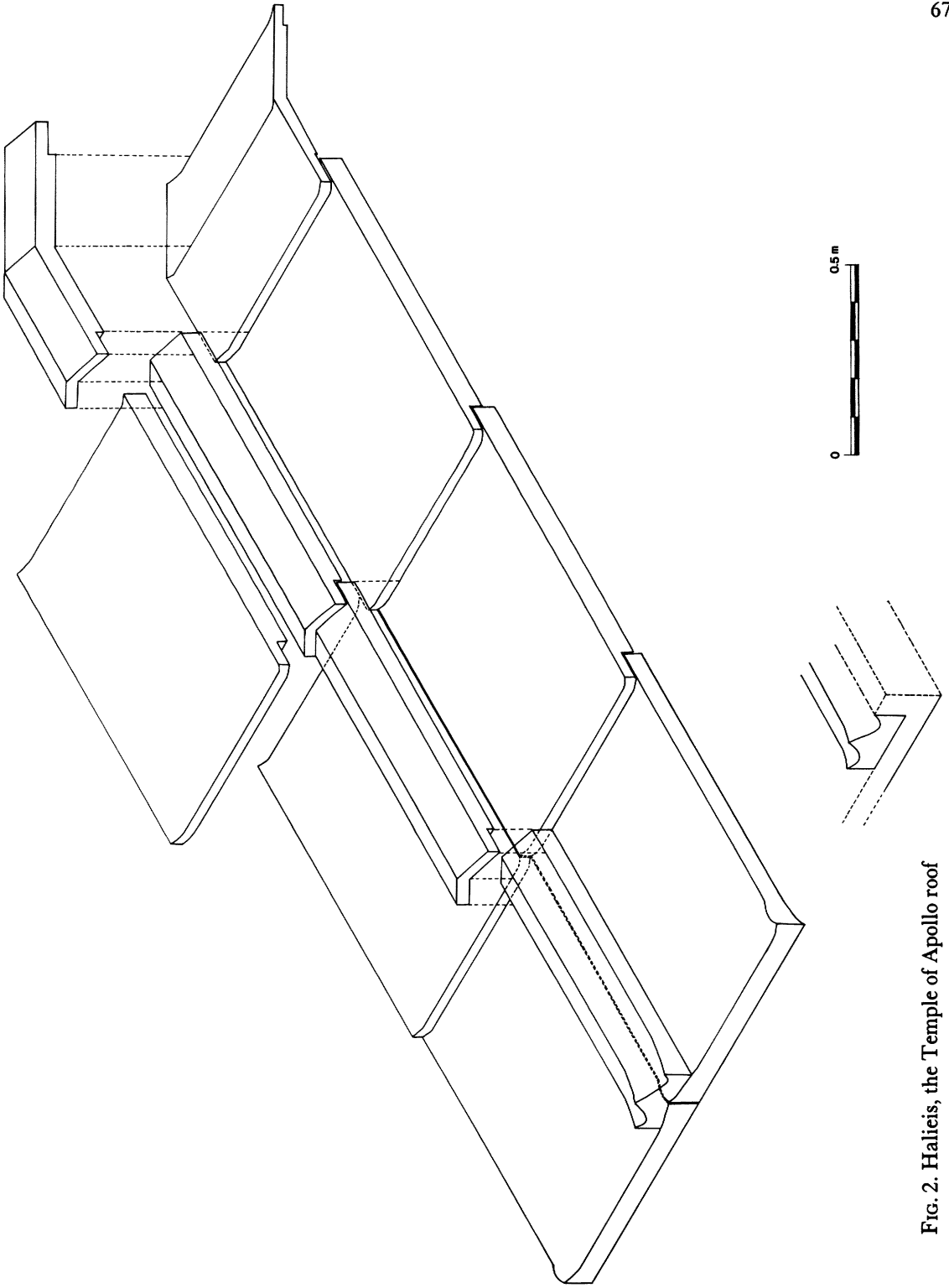

FIG. 2. Halieis, the Temple of Apollo roof

THE TEMPLE OF APOLLO: THE HALIEIS ROOF

Long submersion in the sea has damaged the surfaces of the tiles, but the technical design of the roof of the Apollo Temple can still be reconstructed almost in entirety.

Antefixes had flat smooth faces which rose to three peaks, the central peak being higher than the two on either side (Fig. 3, Pl. 9:b). The bottom surface of the antefix face was cut away at an obtuse angle, trimmed to fit the contour of the eaves tiles on which it sat. The faces of the eaves tiles were not of equal height along the length of the eaves of the roof, but followed the contours of the pan tiles, increasing in height where two eaves tiles abutted, directly under the antefix (Fig. 10). The triple peaks of the antefixes raised the faces higher than the cover tile behind.

One fragmentary antefix has a flat bottom and could have been used at the corner of the roof (Fig. 4, bottom). The antefix covered no seam between pan tiles. It would have sat against the back edge of a sima, which was probably no more elaborate than a pan tile with a turned-up edge.

Only two small fragments of eaves tiles have been inventoried and both are from the lower corners of the tiles (Fig. 5, top). The eaves tiles projected beyond the edge of the wall plate by 0.10 m., and the undersides were molded into a sharp overhanging drip edge. This overhanging portion of the tile could not have been doweled or rabbeted. There is no indication of the method by which they were attached to the roof. No evidence of dowel holes was found on any tiles from this roof. The two small fragments of eaves tiles indicate the method by which the antefixes were secured. On the top surface of the tile, at the edge which abuts the next eaves tile, a triangular lump of clay formed a wedge against which the antefix was securely braced. The underside of the antefix was hollowed to fit (Fig. 5, center). This system makes doweling of the antefix unnecessary.

All pan tiles were flat bottomed. The undersides were cut back on the lower edge to abut and overlap the next tile below (Fig. 5, bottom). The usual length of the overlap was 0.08 to 0.10 m. Since the tiles were eroded from long submersion in the sea, there is no slip left on the surface. The edges, however, still retain their original shape. Each edge of the pan tiles was smoothly finished, and the long abutting edges rose to sharp peaks. Several complete pan tiles were joined together from fragments (Fig. 6); they measured 0.82 m. long by 0.55 m. wide. The cover tiles had cut-backs identical to those on the regular pan tiles, and the covers also overlapped the tile below by about 0.08 to 0.10 m. One complete cover tile was joined together from three fragments and provides the measurements of 0.811 m., length, and 0.165 m., width (Fig. 4, top and center). There were no bevels or moldings at the edges of any of the tiles.

Saddle-shaped pan and cover tiles folded over the ridge beam; these extended 0.30 m. down the roof on each side. The slope of the roof is easily calculated from these well-preserved ridge tiles. The angle at the peak of the roof was 150° , and so the angle at the eaves was 15° (Fig. 7).

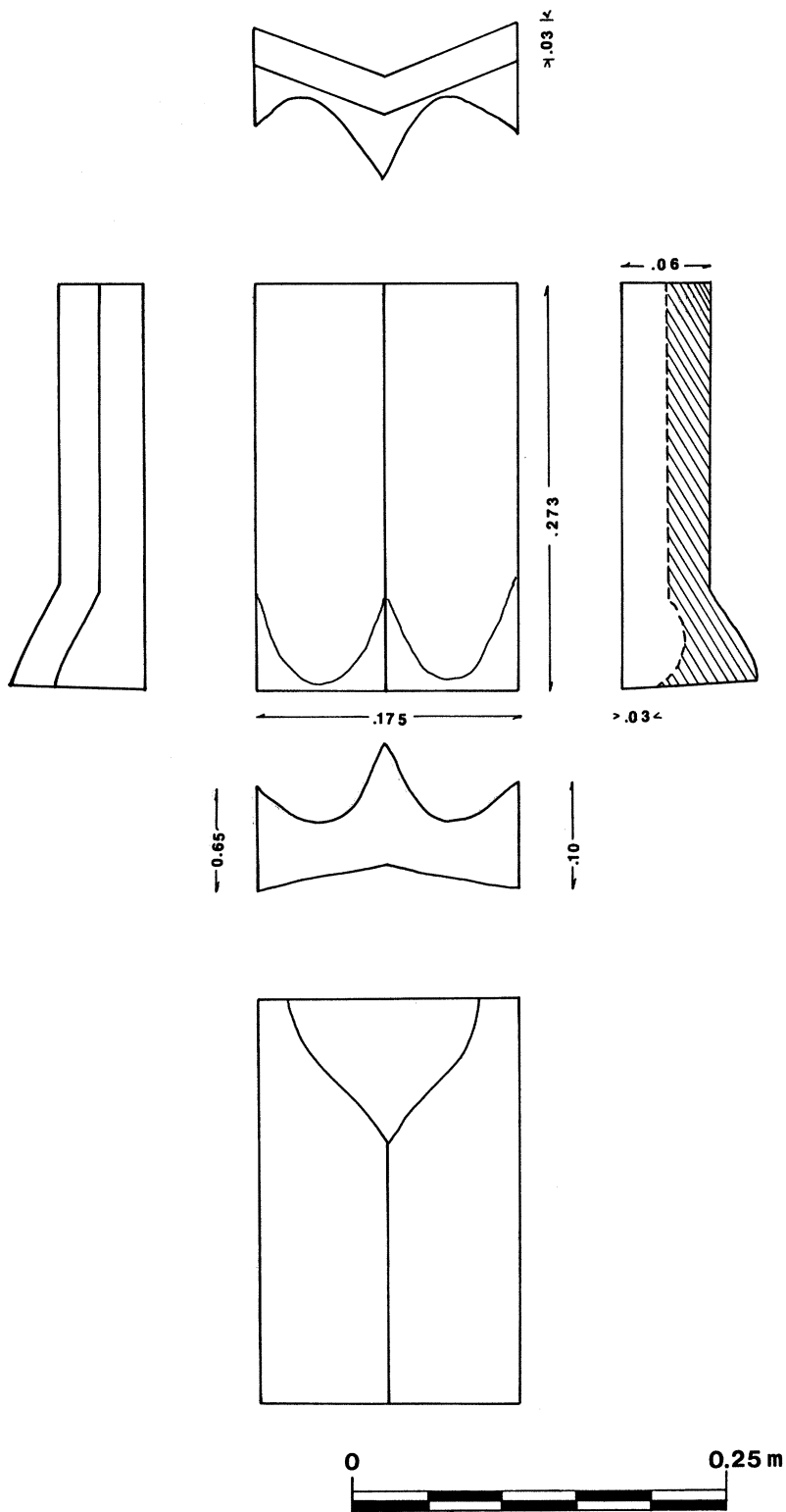
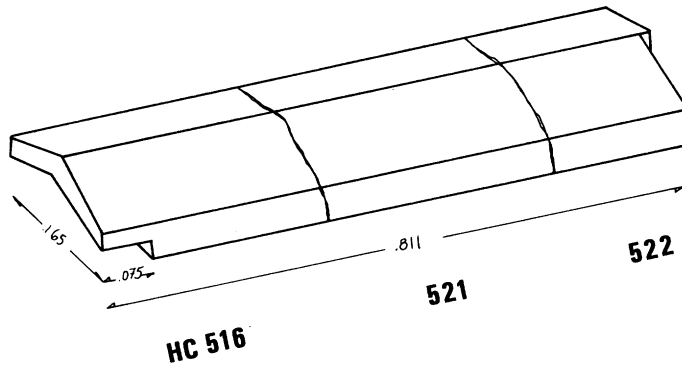
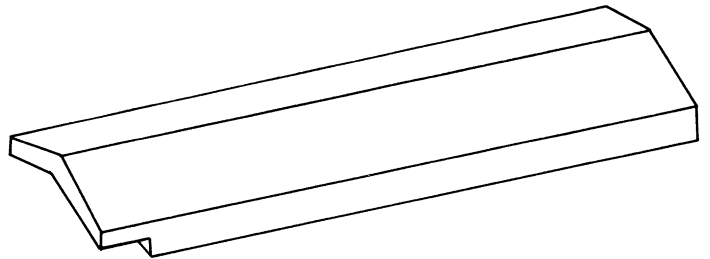
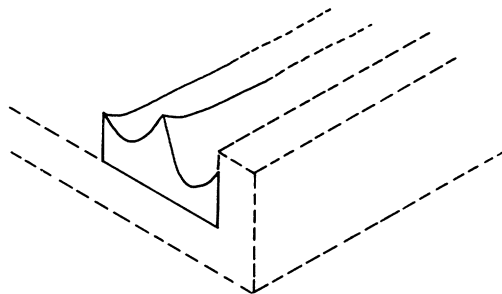

FIG. 3. Halieis, the Temple of Apollo roof, antefix reconstruction



HALIEIS COVER TILES



**HALIEIS
CORNER RECONSTRUCTION**

FIG. 4. Halieis, the Temple of Apollo roof, cover tiles and corner reconstruction

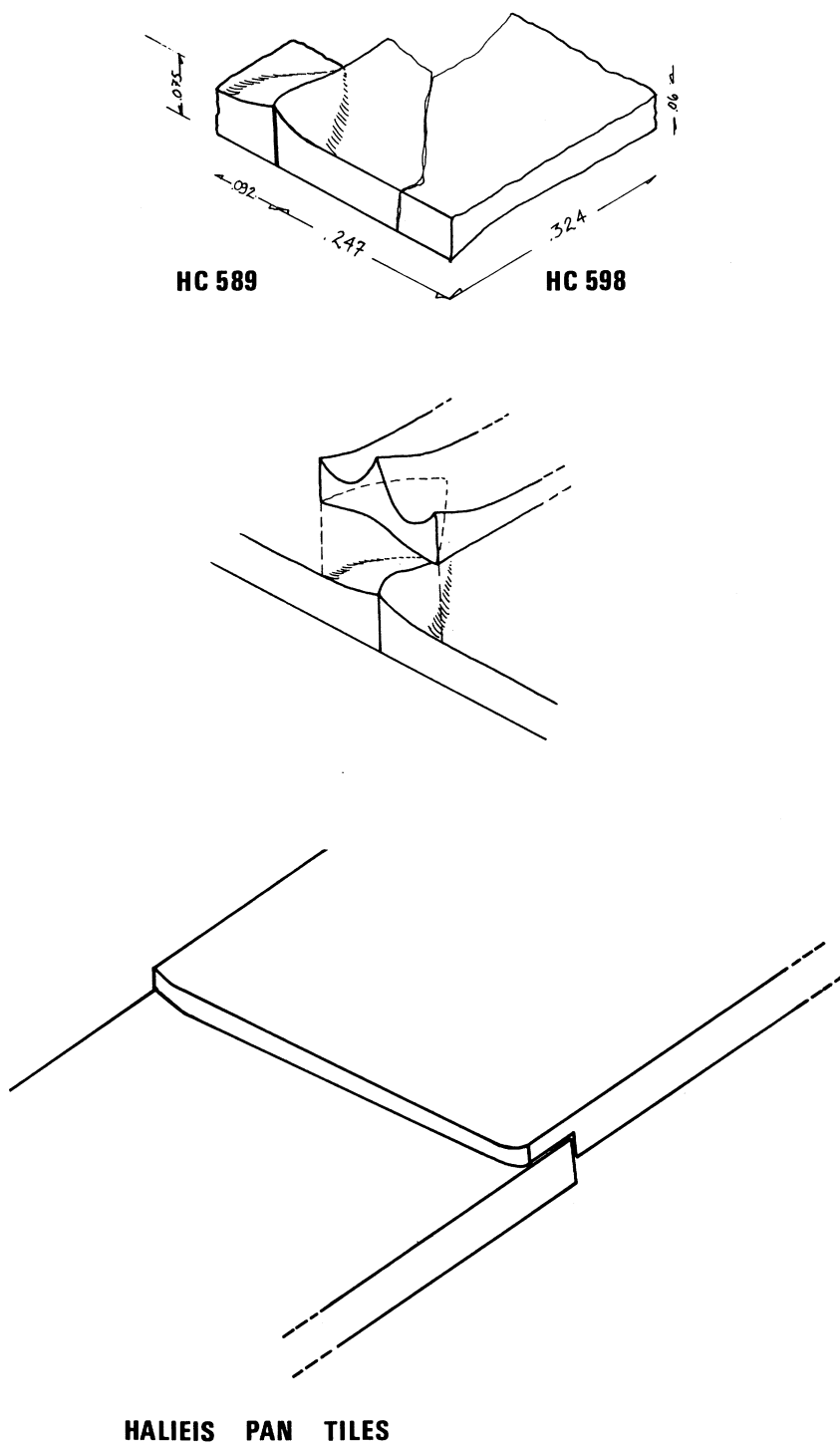

HALIEIS PAN TILES

FIG. 5. Halieis, the Temple of Apollo roof, eaves tiles, antefix construction, and overlapping pan tiles

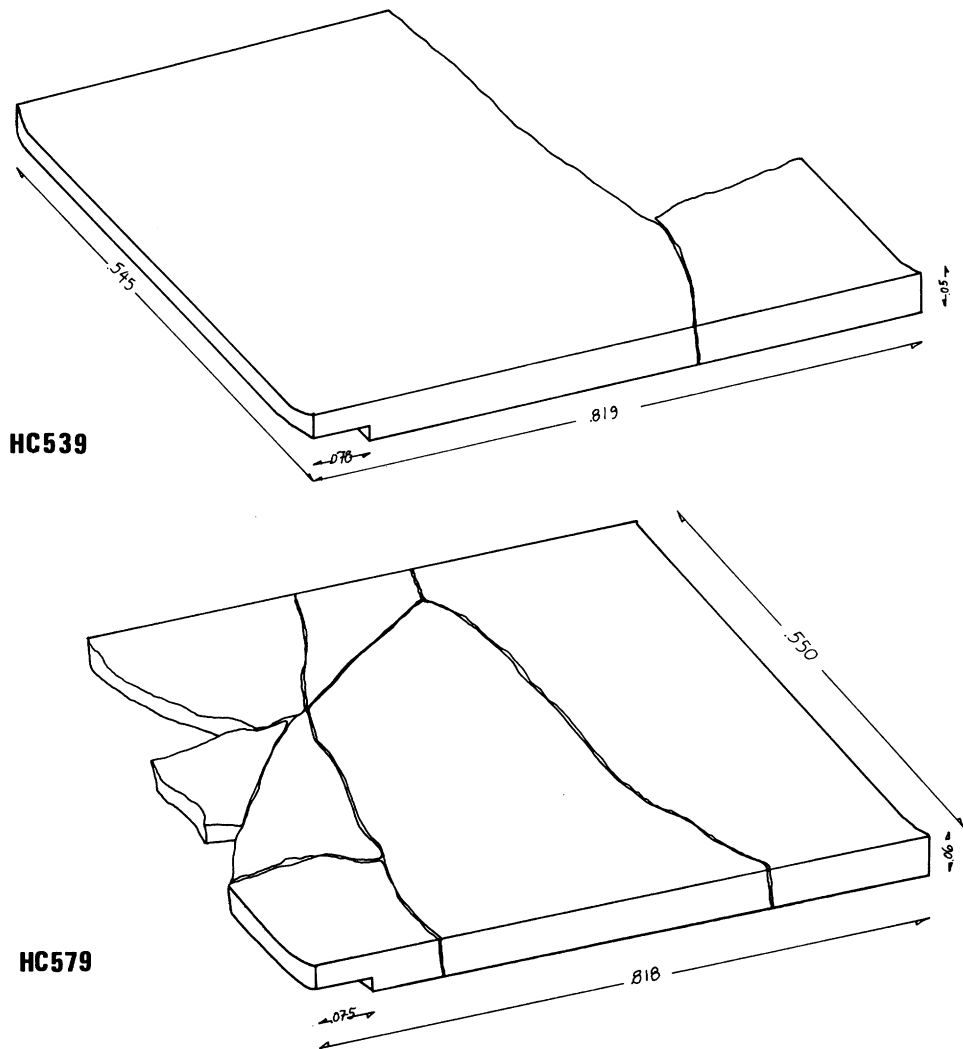
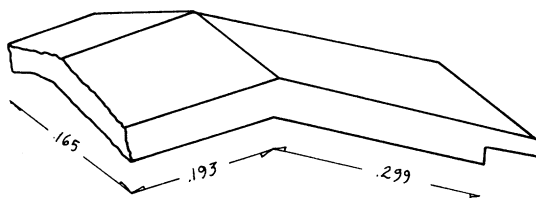

FIG. 6. Halieis, the Temple of Apollo roof, pan-tile fragments

Calculation of the module used in construction of the Apollo Temple produced the “Halieis foot” of 0.273 m.⁶ The size of a pan tile expressed in “Halieis feet” is 3 feet long and 2 feet wide. The agreement between the module of the tiles and the module used in the ground plan is confirmation that the tiles belonged to the building. The longest preserved cover tile attached to an antefix is 0.27 m. At the eaves, it is possible that the pan eaves tiles and cover tiles forming the back of the antefixes were 1 Halieis foot long (Fig. 8, bottom). A

⁶ F. Cooper will publish full details in *Halieis II*. T. Boyd and W. Rudolph (“Excavations at Porto Cheli and Vicinity, Preliminary Report IV: The Lower Town of Halieis, 1970–1977,” *Hesperia* 49, 1980 [pp. 333–355], p. 340) published a preliminary notice of the foot measurement.



HC 543

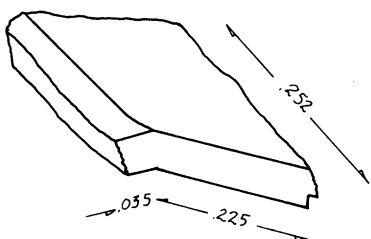

HC 544

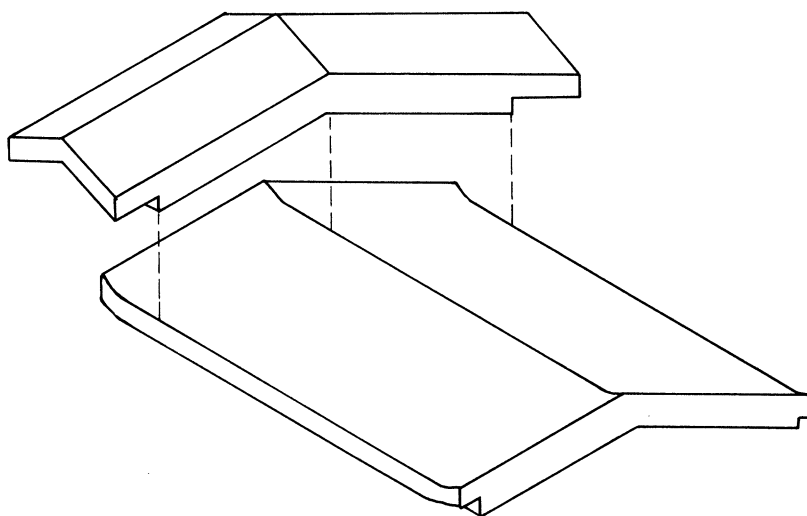

HALIEIS RIDGE TILES

FIG. 7. Halieis, the Temple of Apollo roof, ridge-tile fragments and ridge reconstruction

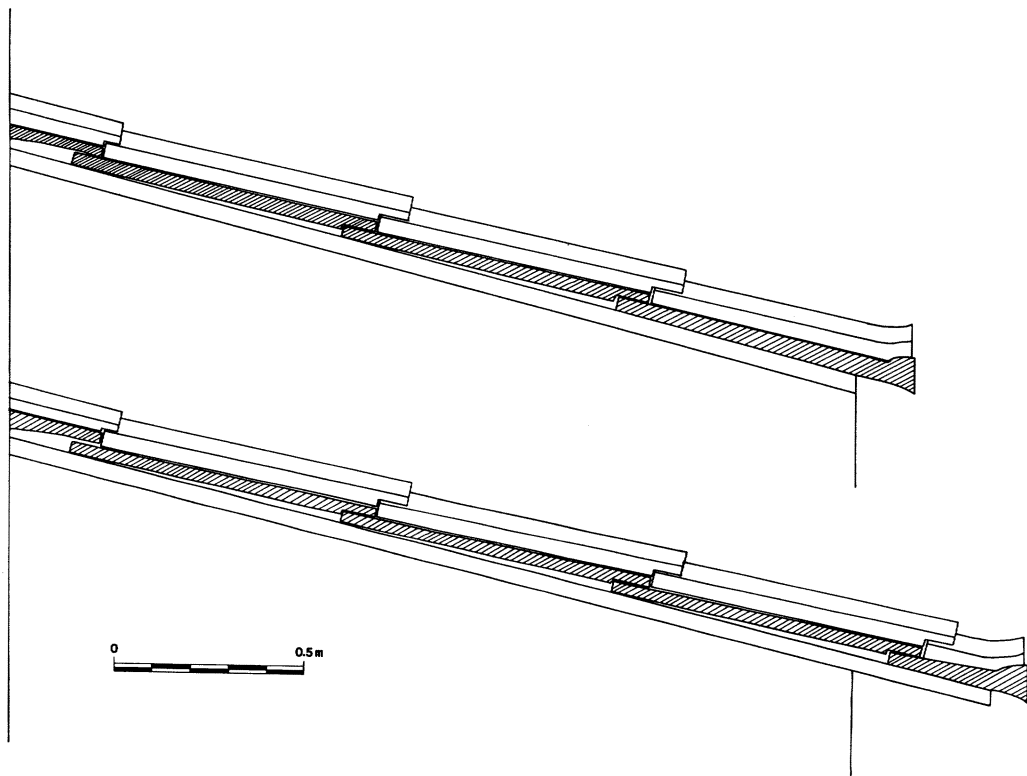

FIG. 8. Halieis, the Temple of Apollo roof, two possible reconstructions, sections

reconstruction with short eaves tiles gives an overhang of approximately 0.50 m. Between the two temples is a drainage channel, the edge of which runs along the side of the Apollo Temple at a distance of 0.50 m. from the wall, to catch the run-off from the two temples.

The Halieis roof is characterized by the three-peaked molded decoration on the antefixes and by pan and cover tiles of distinct profile which are not joined to each other. Similar tiles have been found elsewhere in the Peloponnese, at Mases,⁷ Nemea,⁸ Argos,⁹ and Kombothekra,¹⁰ at Aigina,¹¹ and on mainland Greece at Delphi (Fig. 9).¹² At Mases, on the Franchthi headland in the Argolid, one part of an antefix was recovered. Nothing more is known of

⁷ J. Dengate, "The Archaic Doric Temple at Mases," *Abstracts of Papers 76th General Meeting, Archaeological Institute of America, 1974*, Section IIA, p. 123.

⁸ S. Miller, "Excavations at Nemea, 1979," *Hesperia* 49, 1980 (pp. 178–205), p. 178, pl. 39.

⁹ C. Pfaff (pp. 149–156 below).

¹⁰ U. Sinn, "Das Heiligtum der Artemis Limnatis bei Kombothekra," *AM* 96, 1981, pp. 25–71; K. Müller, "Artemistempel bei Kombothekra," *AM* 33, 1908, pp. 323–326.

¹¹ A. Furtwängler, E. Fiechter, and H. Thiersch, *Aegina. Das Heiligtum der Aphaia*, Munich 1906, fig. 119; Schwandner, 1985; E.-L. Schwandner, "Der Ältere Aphaiatempel auf Aegina," *NFGH* (pp. 103–120), fig. 8, p. 115; E.-L. Schwandner and D. Ohly, "Aegina, Aphaia Tempel," *JdI* 86, 1971, p. 534.

¹² Le Roy, 1967, pl. 5:2 and p. 28.

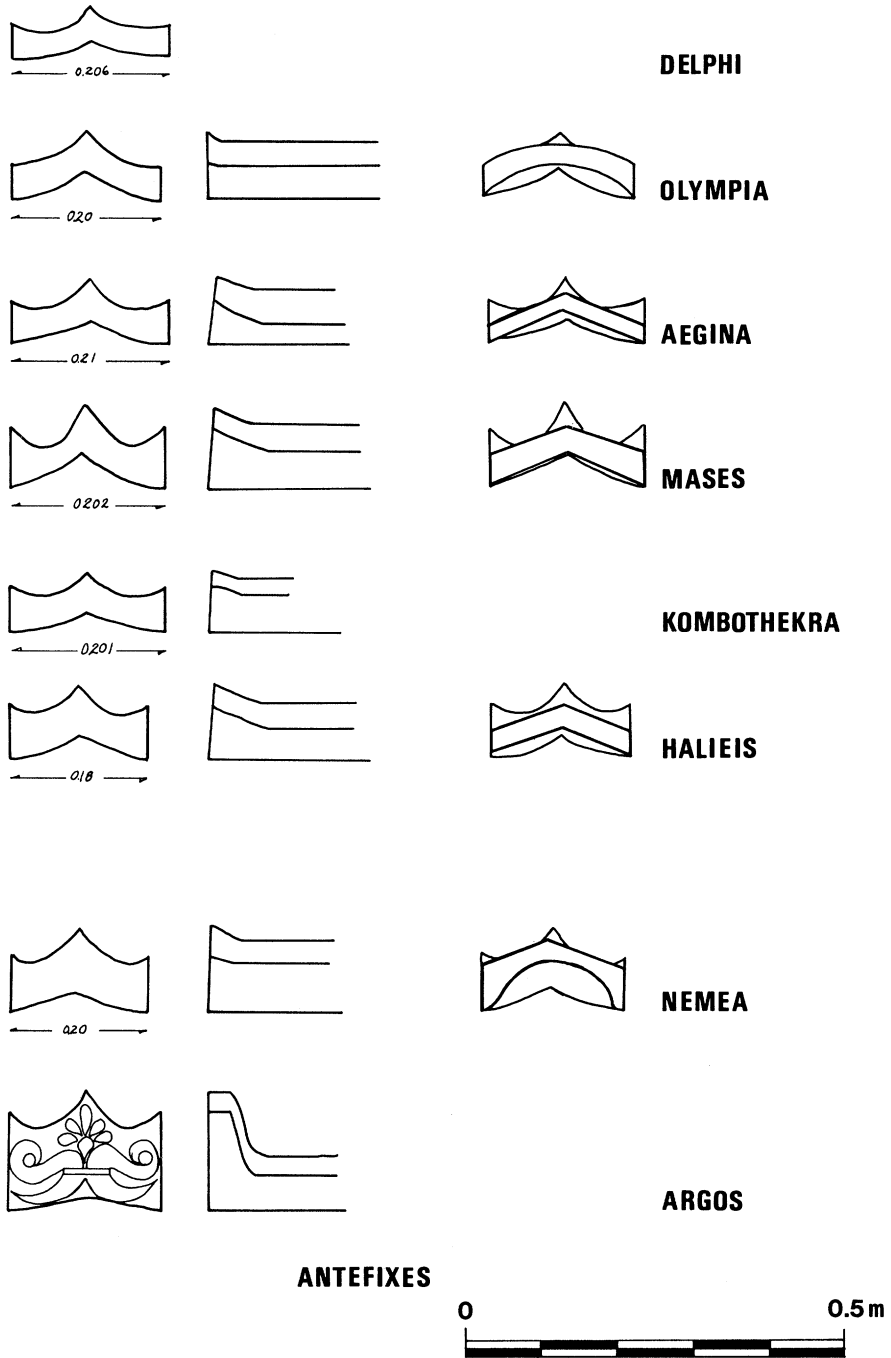

FIG. 9. Three-peaked antefixes, comparison

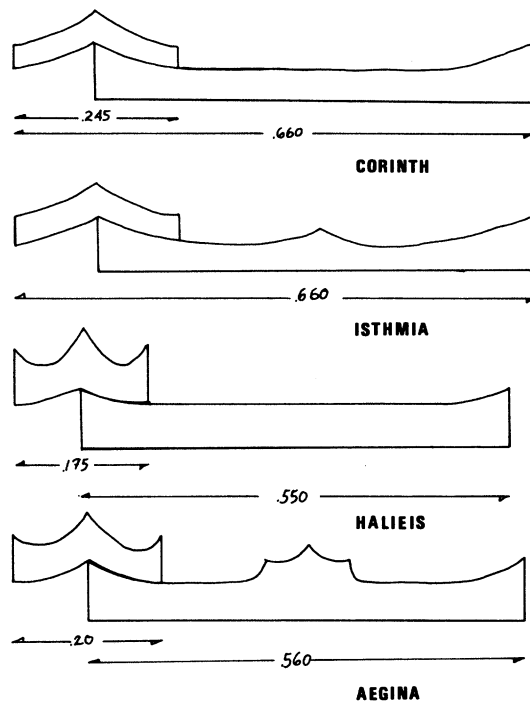

FIG. 10. Antefix and eaves tiles, comparison

this roof; the site is unexcavated. The Mases antefix still retains traces of a dark red color, which is like the color on the Aegina tiles. The Halieis antefixes were probably red also.

At Aegina the eaves tiles had decoration also. The three-peaked projections at the center of the eaves tile formed pseudo-antefixes echoing the shape of the antefixes, in smaller scale (Fig. 10). This decoration was not found at Halieis. It would seem that this added feature of the Aegina tiles would make the roof later in date than the Halieis roof, but the ridge tiles at Aegina are of a more primitive type than those at Halieis. The Aegina ridge pan tiles are very narrow, only 0.10 m. on each slope of the roof; those at Halieis, 0.30 m. The Aegina ridge is closer in design to the "Protocorinthian" roof at Corinth (Roebuck, p. 48 above, fig. 1).¹³ The Isthmia version of the Protocorinthian roof is dated slightly later than the Corinth one and has the added decoration of one peak on the eaves tile (Fig. 10).¹⁴ The reverse situation may exist with the Halieis and Aegina roofs. The earlier has the added decoration, the later does not. The improvement of the design of the Halieis tiles at the peak of the roof is strong evidence that it should be dated after the Aegina roof.

¹³ Robinson, *AM*, p. 56, fig. 1. At the ridge the "Protocorinthian" roof has a strong horizontal row of tiles whose dimensions represent the size of the beam on which they sit.

¹⁴ O. Broneer, *Isthmia, I, Temple of Poseidon*, Princeton 1971, p. 121.

The Halieis-style roof should represent the next stage of development after the Corinth and Isthmia “Protocorinthian” roofs. The Halieis tiles are not combination tiles; each pan and cover is a separate piece. This would seem to be a step backwards, but separate tiles would have made the actual fitting of the tiles on the roof more simple and would have eliminated most of the cutting of the upper edges of the tiles that occurs on the “Protocorinthian”. There are also design advances: the Halieis tiles were flat bottomed and the ridge tiles more stable. The ridge pan and cover tiles were much longer and therefore much heavier, in fact three times the length of the 0.10 m. ridge tiles of the “Protocorinthian” roof. The tiles were stabilized by their own weight, and no dowels or nails were needed to secure them to the ridgepole of the roof.

Of the three-peaked antefixes found at various sites, only at Halieis can the foundations of the temple to which they belonged be positively identified and something said of the nature of the building. The temple was long and narrow, divided into several chambers, was oriented north–south, had an entrance on the south facing the altar and other doors on the west. There were no stone columns and no ashlar masonry. The walls may have been constructed of mud brick above a socle made of roughly worked stones. The temple was not peripteral. To walk along the east side meant passing through a meter-wide space where two roofs nearly met overhead. The landscape of the passageway consisted of a drain.

The foundations of the Temple of Apollo seem early, and pottery dating from the second quarter of the 7th century B.C. was found inside.¹⁵ The roof system of the temple is an early one. The most straightforward conclusion is that building and roof are part of one building period; however, the pottery does not necessarily date the architecture.

The three-peaked antefix roof should be original to this building, whatever its date. If it is true, however, that the similar tiles at Aigina and Mases were used on fully developed Doric stone temples and should be dated to the first quarter of the 6th century B.C., then the Halieis roof must have replaced an earlier roof, which was made from a perishable material, such as thatch. This could not have been a simple alteration because the weight of the terracotta revetment would have needed a stronger wooden roof structure. In the temple, some stone bases were found that could have supported a series of wooden columns along the interior walls.¹⁶

TEMPLE II: THE LACONIAN ROOF

The remains of the foundations of Temple II at Halieis give no indication of the interior plan, of the orientation of the façade, or of the function or date of the building. The superstructure was completely robbed; only a few finds similar to those in the Temple of Apollo and a thick layer of shattered tiles were left behind. The remains of the roof are not sufficient to allow a detailed restoration of all aspects of its appearance; some important features,

¹⁵ Jameson (footnote 3 above), p. 367.

¹⁶ If this is the case, and such a change seems to have taken place at Bassai and Kalapodi as well, perhaps this can be seen as the origin of the interior colonnade.

however, are certain. The roof was a typical Laconian roof with a ridge cover and an akroterion disk (Fig. 1).

One nearly complete pan tile was pieced together from many fragments and was approximately 0.45 m. wide and 0.95 m. long (Fig. 11). No full-length cover tiles were found, but the length was necessarily the same as that of the pan tile. The covers widen from 0.17 m. at the upper edge to 0.22 m. at the lower and form a flattened curve in profile. The dimensions and profiles of the Halieis Laconian roof tiles are remarkably similar to the tiles from the early Temple of Apollo at Bassai (Fig. 17).

Of the several geison tiles one slab is preserved with its full width (Fig. 12). Two fragments join and measure 0.45 m., exactly the width of the upper end of a pan tile. The length is not fully preserved but measures 0.36 m. on the best example. The overhanging portion is slightly concave on the front face, preserved to a height of 0.15 m. which must be nearly the full height. The underside, meant to be seen from below, carries a molding. There is a hole in one fragment which could have been used to attach the geison to the woodwork below.

There are eleven identifiable fragments of the ridge cover. Only two areas of the ridge-cover tiles have edges which permit them to be distinguished from the mass of shattered tiles recovered during excavation: those portions which were cut to fit over the cover tiles which ended at the ridge of the roof, and the rim which was overlapped by the adjoining section of the ridge cover along the ridge of the roof. The other end of each ridge cover, which overlapped the rim of the next one, may have been plain, with no distinctive moldings. A more usual design was that with one or more tori along the overlapping edge,¹⁷ but nothing with this shape was recovered.

The overlapped rim of the ridge-cover tile was molded in such a way as to provide a completely waterproof seal (Fig. 13). The rim projects from the body, and the part of the molding just at the overlap forms a tiny gutter, which carries away water entering the joint. The water is directed into the center of the pan tile below, and flows off down the roof. Six rim fragments have been catalogued, and a composite of the diameters provides an estimate of the size and shape of the ridge cover. It is not semicircular in section: the sides rise straight up 0.12 m. before they curve over the top. The approximate height and width are the same, 0.30 m.

Five fragments from the body of the ridge cover contain some portion of an aperture which fit over the tops of the cover tiles at the ridge of the roof. Although no fragment of the ridge cover preserves a complete aperture, there are enough fragments from different points along the curve to allow a reconstruction of the full arc. The curve agrees exactly with the profile of the flat arc of the top of a cover tile. Also, the edge of the aperture is undercut to correspond to the angle of the junction of the ridge cover and cover tile, giving the approximate slope of the roof, which is slightly less than 15° (Fig. 14, top). The length of the individual ridge covers could not be recovered but may be restored as being equal to the width of the upper edge of a pan tile. The joints of the ridge cover would then fall at the centers of the

¹⁷ For example, see W. George and A. Woodward, "Architectural Terracottas," in *The Sanctuary of Artemis Orthia at Sparta* (JHS Suppl. 5), R. M. Dawkins, ed., London 1929, pl. 27 and p. 132, fig. 100.

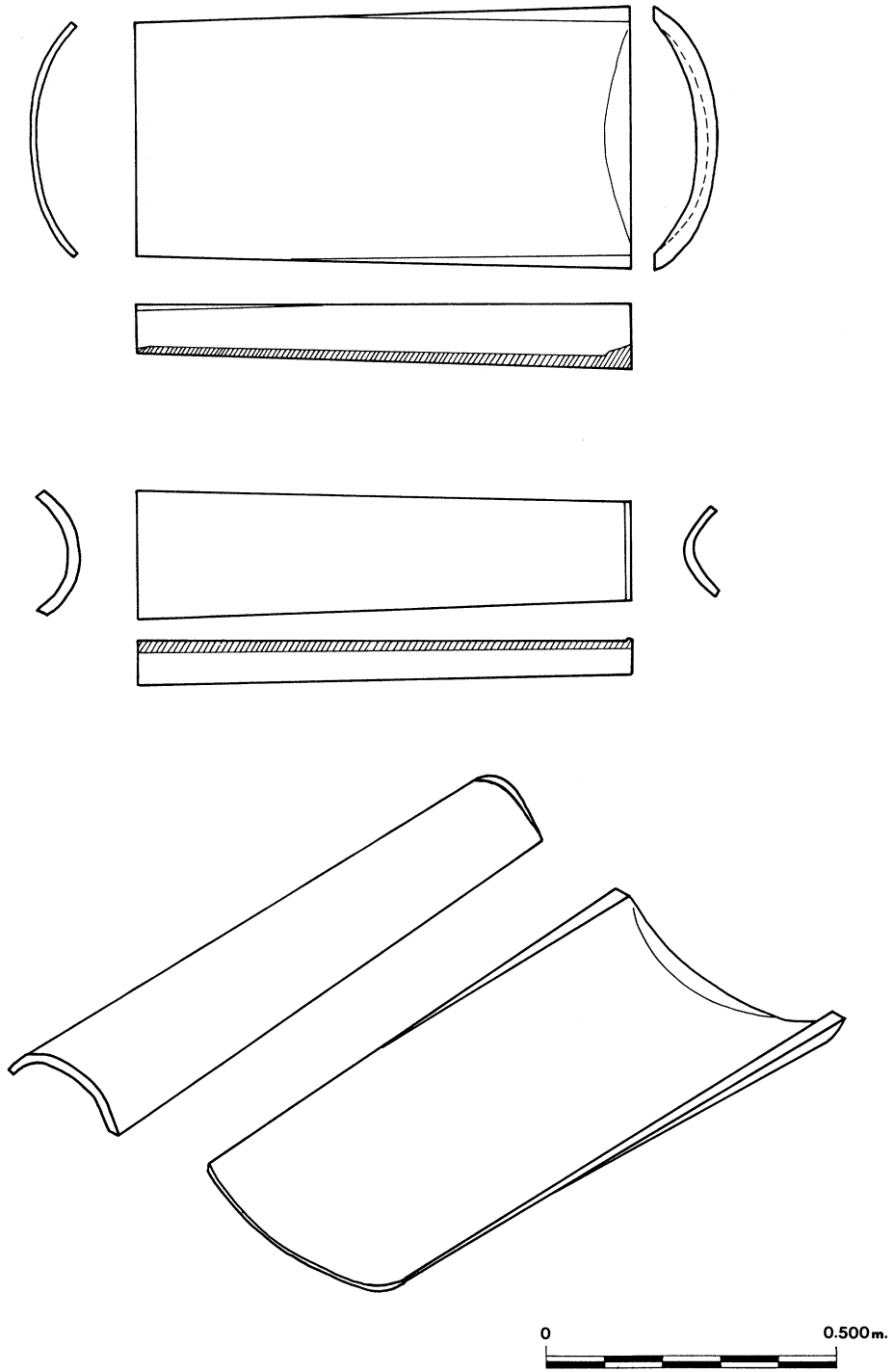

FIG. 11. Halieis, Roof II, reconstruction of pan and cover tiles

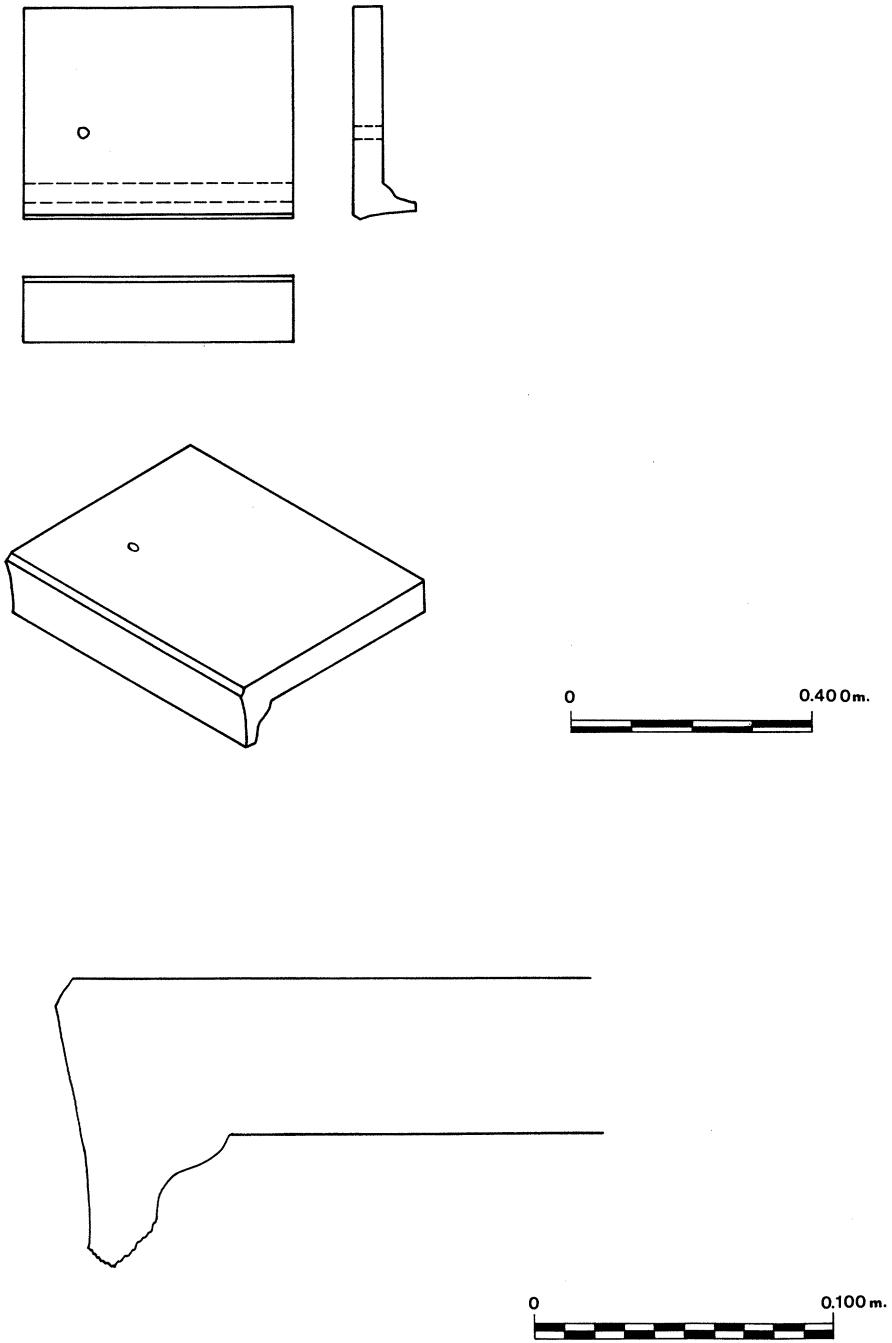

FIG. 12. Halieis, Roof II, reconstruction of geison tile

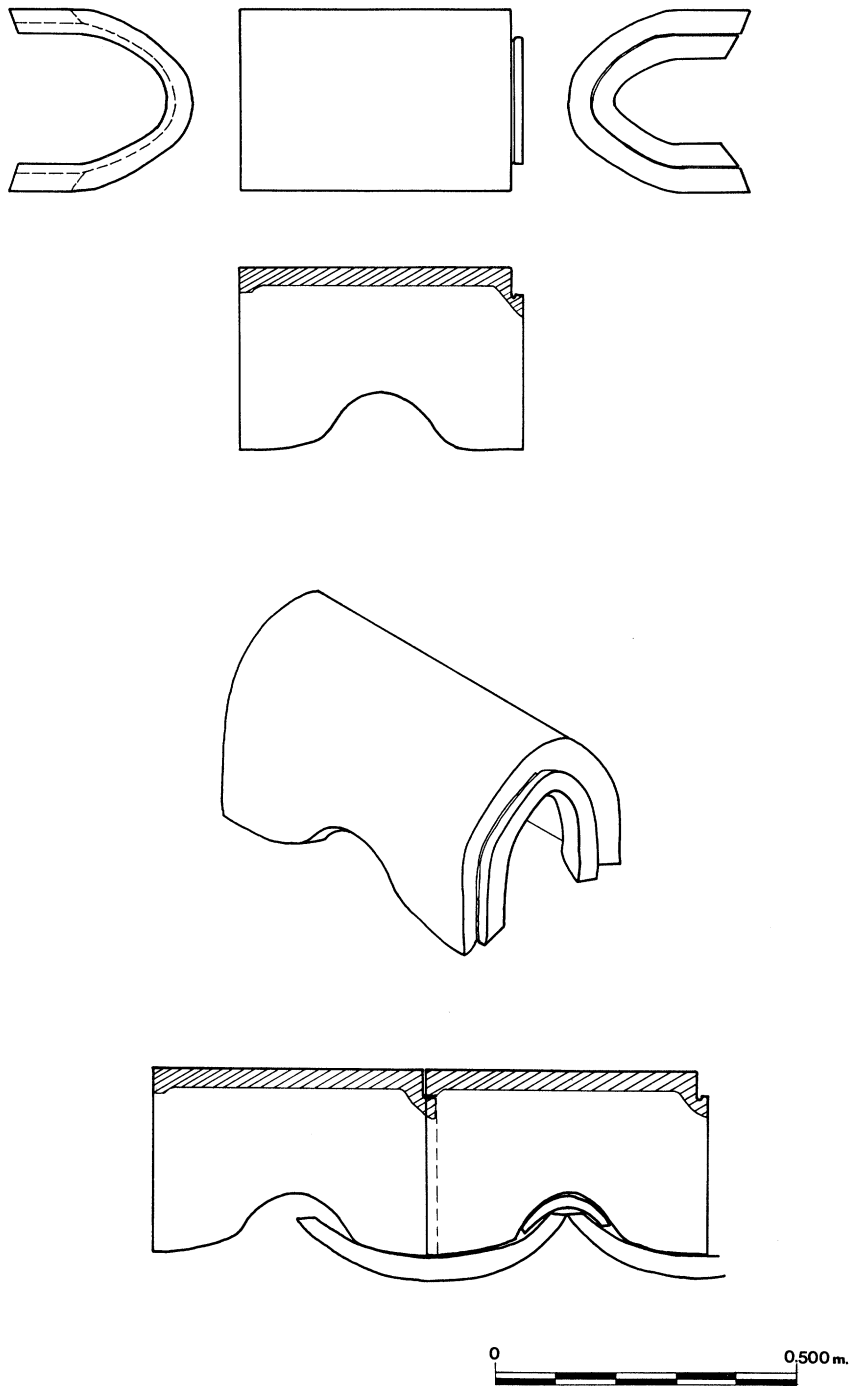

FIG. 13. Halieis, Roof II, reconstruction of ridge cover

pan tiles along the ridge of the roof. An arrangement of four tiles on each side of the slope of the roof would make an overhang of approximately 0.50 m., since the temple is 6.45 m. wide (Fig. 14, top). No antefixes were found.

Five fragments of an akroterion disk were found. Three fragments are shown on Plate 9:a. None of the fragments join, and all are badly preserved. No trace of painted decoration remains, and the surface of each piece is so damaged by water that only traces of the decorative moldings on the face of the disk remain. The back surface of one fragment preserves a trace of a connecting strut, which probably connected directly to the ridge cover.

The face of the disk was decorated in concentric zones, consisting of tori, flat areas, and moldings. All the zones were probably painted. Those fragments which have some traces of the decorative moldings preserved give an approximate diameter for each zone of molding. A fragment from the outer edge of the disk seems to have broken saw-toothed projections. The diameter of the disk can be restored to about one meter (Fig. 15). The preserved moldings are typical of those which occur on other similar disks, such as that of the Heraion at Olympia, or those from Bassai.¹⁸ Since these disks have two separate zones of three or four concentric tori, it is possible that some zones are not represented among the preserved fragments from the Halieis.

Mallwitz has divided akroterion disks into two classes: the Heraion type and a coarse type, which instead of a saw-toothed outer zone has alternating rounded and pointed leaves.¹⁹ The outer edge of the disk of Temple II at Halieis is not well enough preserved to indicate to which type it belonged. The absence of any trace of painted decoration is also an obstacle to arriving at a more specific date for the Laconian roof at Halieis. Generally, however, such akroterion disks are dated to the 6th century B.C.

The fact that Temple II at Halieis was decorated by an akroterion disk is the proof that it was a temple. Treasuries and possibly fountain houses are the only other buildings known to have been decorated with disks, and the foundations at Halieis are too large to belong to either of these. The Archaic sanctuary at Halieis thus included two temples, side by side, facing an altar. The design of one roof was in direct contrast with the other. The roof of the Temple of Apollo was plain, in an early stage of development of this type. The Laconian roof was more elaborate. The buildings were in use simultaneously.

BASSAI

During the Early Archaic period, there were three temples in the sanctuary at Bassai. Two stood together in a narrow valley near the summit of Mt. Kotion. A little down the slope was the Archaic Temple of Apollo, known first from the recovery of decorated architectural terracottas in the area around the Classical temple. The exact location of the Archaic temple was not known until 1970, when the foundations were recognized directly to the south of the

¹⁸ N. Yialouris, «Τὸ ἀκρωτήριο τοῦ Ἡραίου Ὀλυμπίας», in *Χαριστήριον εἰς Ἀναστάσιον Κ. Ὀρλάνδου* IV, 1967–1968, pp. 57–65; Yialouris, “Problems,” pl. 34:c.

¹⁹ A. Mallwitz, “Ein Scheibenakroter aus Olympia,” *AM* 83, 1968 (pp. 125–146), p. 133.

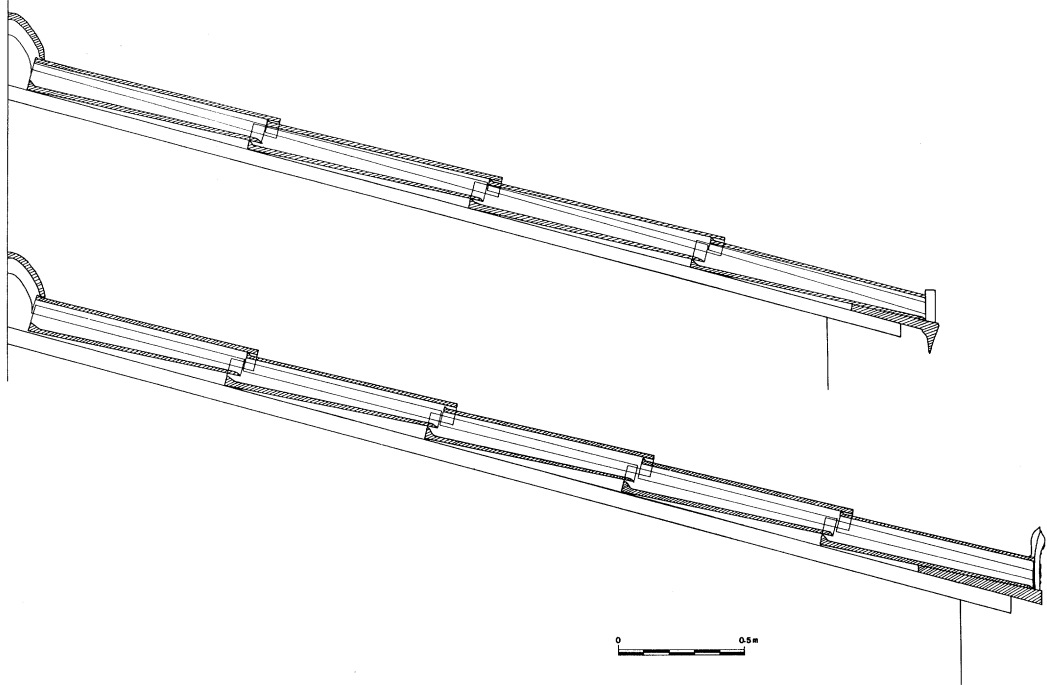

FIG. 14. Halieis, Roof II (top) and Bassai (bottom), sections

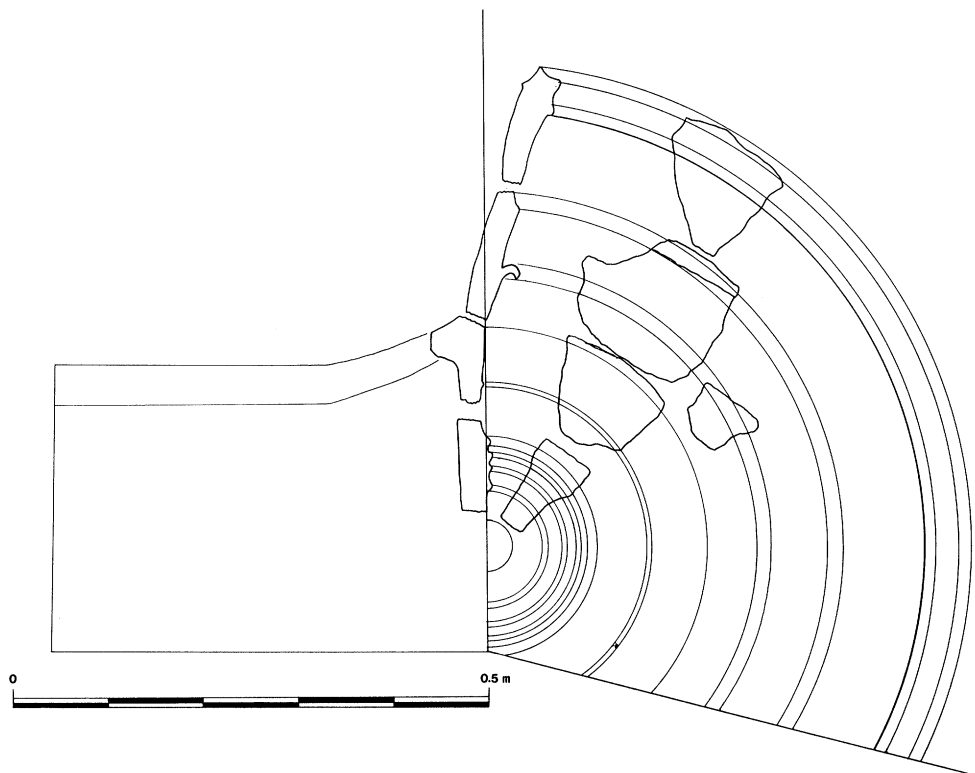

FIG. 15. Halieis, Roof II, reconstruction of akroterion disk

Classical temple, during the excavations conducted by Nicholas Yialouris.²⁰ Its outlines had always been visible at the site and had been sketched on Kavvadias' site plan in 1903,²¹ even though they were not recognized (Fig. 16). The location, orientation, and ground plan of the Early Archaic temple were copied by the Classical temple and provide a rare confirmation of the theory that Archaic temple planning had a profound influence on later building. A study of the design of the Early Archaic temple explains many of the anomalies of the design of the Classical temple, including the roof.²²

THE TEMPLE OF APOLLO: THE LACONIAN ROOF

The Archaic terracottas consisted of fragments of two sets of Laconian tiles, including antefixes decorated with heraldic sphinxes, and akroterion disks.²³ More fragments of the Archaic roof were found by Yialouris in his excavations in the 1950's and 1970's.²⁴ Yialouris has published a photograph of the reconstructed akroterion disk "A"²⁵ which differs substantially from the earlier description and drawings. The "A" disk has the so-called "hallmark" of Laconian pottery, a pomegranate frieze, which can be dated to the end of the first quarter of the 6th century B.C.²⁶

Rhomaïos distinguished two sets of architectural terracottas in his study of the disk and antefix fragments, based upon the two different clays used.²⁷ He described one clay as being fine and dense with a yellow color (type "A"), the other more red in color, rough and gritty ("B"). The clay of the tiles, both undecorated and decorated, found in the later excavations is easily recognized as fitting Rhomaïos' two categories. But although two types of clay are used, the fragments of the two sets were almost identical, as if one set served as full or partial replacement for the other. The fragments of "B" tiles greatly outnumber "A" tiles at the site.

²⁰ N. Yialouris, «Δοκιμαστική ανασκαφή εἰς τὸν ναὸν τοῦ Ἐπικουρίου Ἀπόλλωνος Βασσῶν», *Πρακτικά* 1959 (1965), pp. 155–159; *idem*, «Ἀνασκαφαὶ εἰς τὸν ἐν Βάσσαις Φιγαλείας ναὸν τοῦ Ἀπόλλωνος», *ΑΑΑ* 6, 1973, part 1, pp. 39–49; *idem*, «Φιγαλεία, Βάσσαι» *Ἔργον* 1959 (1960), pp. 106–109; Yialouris, "Problems," pp. 89–104; L. Parlama, «Βάσσαι, Ναὸς Ἐπικουρίου Ἀπόλλωνος», *Δελτ* 26, 1971, Β' 1 (1974), pp. 142–146. F. Cooper ("Bassai," in *PECS*, pp. 145–146) has postulated four phases for the Temple of Apollo at Bassai. Phases I and II on the foundations discussed here (the Early Archaic Temple); Phase III directly under the Classical temple (the Late Archaic Temple), consisting of ashlar limestone blocks cut and re-used in the Classical temple and a wall and floor found by Yialouris ("Problems," p. 95 and fig. 2); Phase IV, the Classical temple.

²¹ M. Kavvadias, "Der Apollotempel von Phigaleia," *Comptes Rendus du Congrès International d'Archéologie* I, Athens 1905 (pp. 171–179), p. 175, and K. Kourouniotis, «Τὸ ἐν Βάσσαις ἀρχαιότερον ἱερόν τοῦ Ἀπόλλωνος», *Ἀρχ* Ἐφ 1910 (pp. 271–332), p. 273, fig. 2.

²² "Laconian Tiles from Bassai," in N. Cooper, 1983, pp. 100–111, and *eadem*, "The Archaic Sanctuary at Bassai," *AJA* 84, 1980, p. 202.

²³ K. Kourouniotis, «Ἀνασκαφή ἐν Κωτίλω», *Ἐφ* Ἀρχ 1903 (pp. 151–188), pp. 151–158; *idem* (footnote 21 above), pp. 271–332; Kavvadias (footnote 21 above), pp. 171–179; K. Rhomaïos, «Ἐκ τοῦ ἀρχαιότερου ναοῦ τῆς Φιγαλείας», *Ἀρχ* Ἐφ 1933, pp. 1–25. Rhomaïos dates the roof to 625–600 B.C. Also, some akroterion-disk and antefix fragments have been published in *GFR*, figs. 56, 59, and 60.

²⁴ See footnote 20 above. I must rely on the published photographs, drawings, and descriptions of the disk and antefix fragments for my reconstructions.

²⁵ Yialouris, "Problems," pl. 43:c.

²⁶ J. Boardman, "Artemis Orthia and Chronology," *BSA* 58, 1963 (pp. 1–7), pp. 2–4.

²⁷ Rhomaïos (footnote 23 above), p. 2.

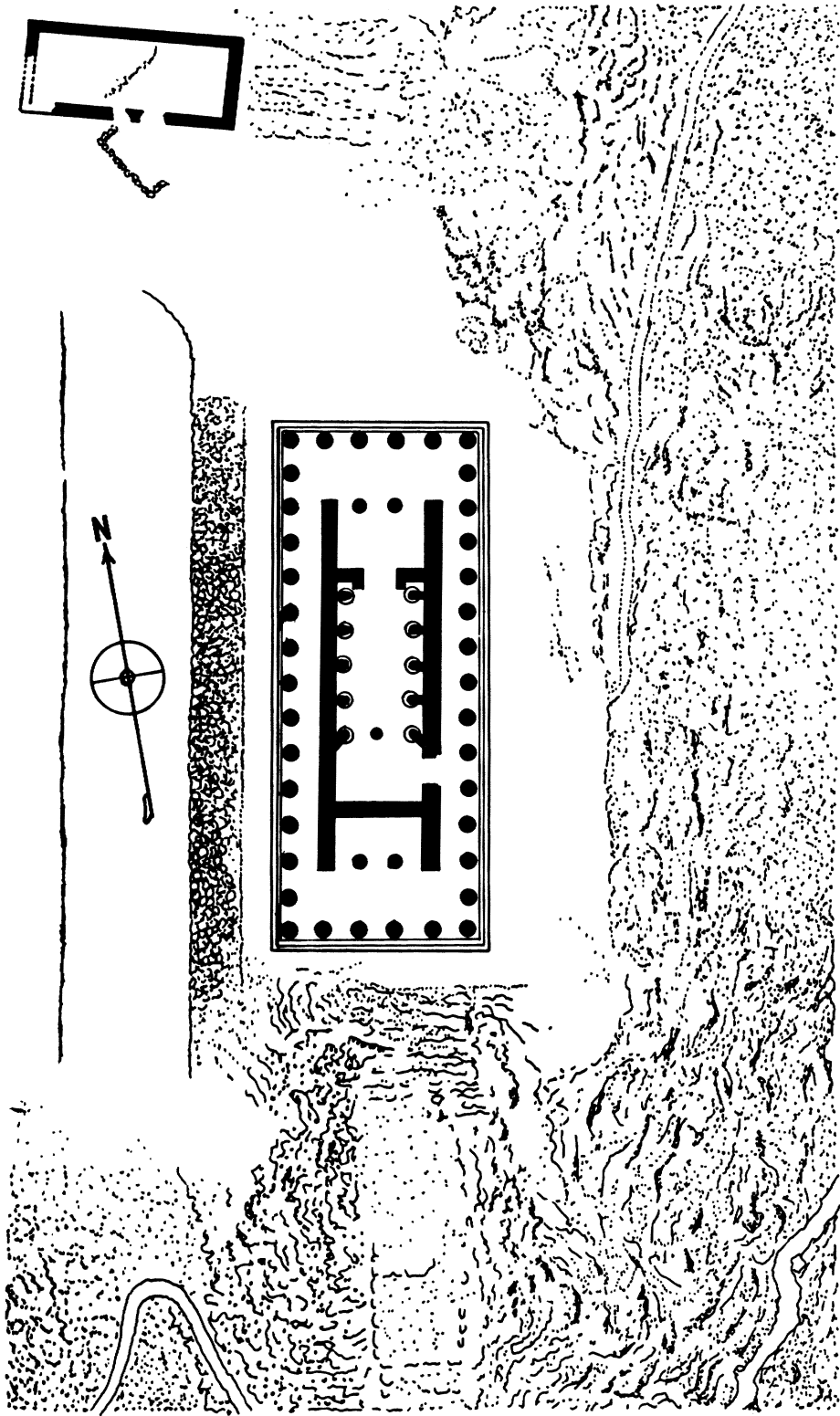

FIG. 16. Bassai, site plan, after K. Kourouniotis, 'Αρχ'Εφ 1910, p. 273, fig. 2

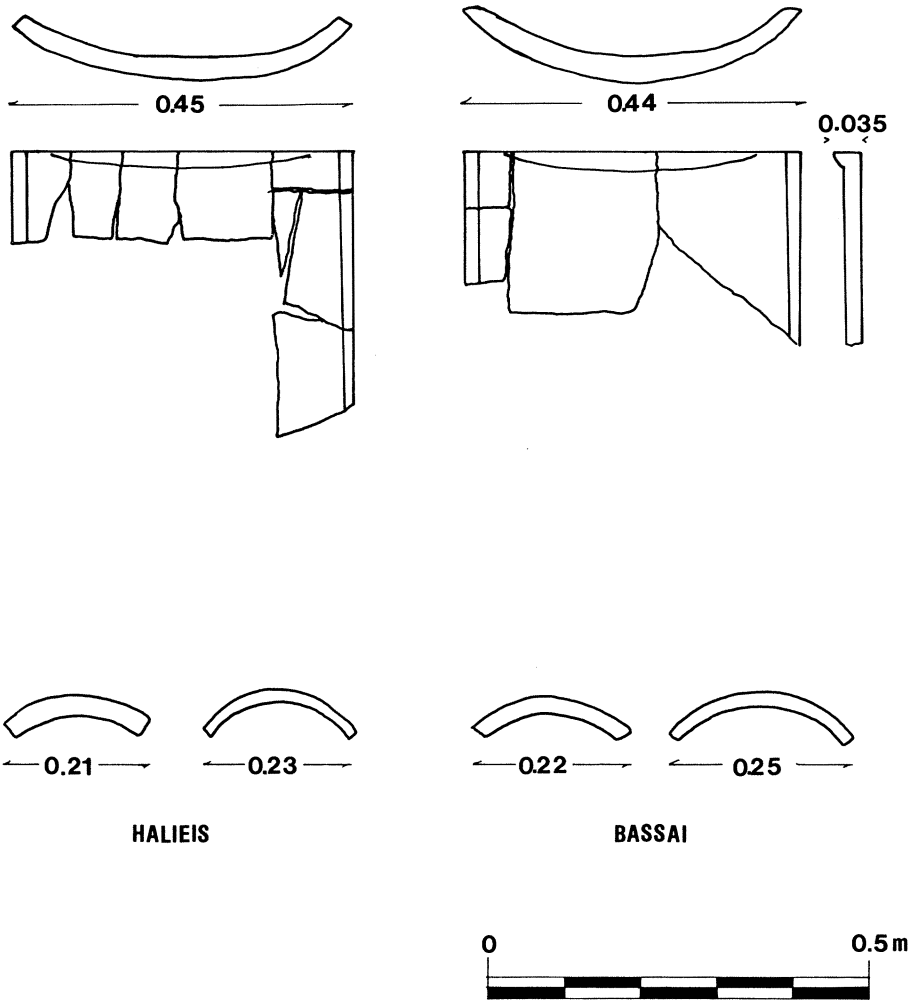

FIG. 17. Bassai and Halieis, fragments of Laconian tiles

Pan-tile width can be measured from three joining fragments from the upper, overlapped edge of one “B” tile, which also provides a profile of the curvature (Fig. 17). The pan is 0.435 m. wide. The overlapping edge of one cover tile is preserved on which the width can be measured as 0.21 m. The length of the pan and cover tiles is not known. Color, both red and black, was found on both the “A” and “B” types of tiles. Some cover tiles had red color, others had black, and the same was true for the pan tiles. Red is less common than black, but no reconstruction of color pattern is possible.

Some fragments of the ridge cover of type “A” have been identified. One preserves the cut-out section that fit over the cover tile and has the same type of beveled edge as the ridge cover of Temple II at Halieis. The color is well preserved: solid black with no pattern

visible. A reconstruction of the roof at the ridge is made possible by these fragments, although some details, such as how the ridge-cover sections joined, are lacking (Figs. 18 and 23). Antefixes of an unusual bi-level design were recovered (Figs. 19 and 20:c, d). Antefixes of both types of clay, "A" and "B", were found. There is some slight variation in detail: "A" antefixes show more fine detail and have fewer filling ornaments (Fig. 20:c). The "B" antefixes have a recessed border 0.02 m. wide, outlining the entire shape of the antefix, while "A" antefixes do not. It is possible that "A" antefixes were slightly smaller than the "B" type. Reconstructed dimensions of the "B" antefix are 0.31 m. wide and 0.245 m. high. Kourouniotes depicts a wavy line painted beneath the sphinxes in one example and says that the top portion of the antefix, the palmette, was dark red and the back black; the sphinxes' bodies were painted red.²⁸ The faces of the antefixes have flat bottoms, which indicates that they sat on the level surface of a geison-tile course.

The sphinx motif of the Bassai antefixes is similar to that on an architectural fragment found at Delphi.²⁹ There is also a similar Laconian antefix from Capua, which has two heraldic sphinxes with one head.³⁰ The Corinthian tiles from the Artemis Temple at Corfu are illustrated together with an antefix fragment, which bears a relief design of a seated sphinx in a heraldic pose, its body facing the center line of the antefix and one paw raised.³¹ The size of this antefix is close to that of Bassai, but it is of the pentagonal Corinthian type, not Laconian. All similar antefixes have been dated to the late 7th—early 6th century B.C.

The Bassai antefix differs in design from those with similar decorative motifs, because it has a palmette perched above the lower half. The palmette is borrowed from Corinthian antefixes. Two Corinthian antefixes from Thasos have figures decorating the pentagonal face, with a palmette above (Fig. 20:a, b).³² The treatment of the figures is like that of those from Bassai: black or dark figures on light ground. Some of the empty space is filled by painted dots in a circle. The Thasos antefixes are from a Corinthian-type roof, not Laconian. The Bassai palmette seems to be less developed than that of the Thasos examples but more developed than the small palmette which decorated a series of Corinthian-type antefixes found at Corinth, Nemea, Kalapodi, and other sites, which have a palmette perched on the peak of a pentagonal face.³³ This series of antefixes does not have figural decoration (Fig. 21).

If compared to other Laconian antefixes, the Bassai antefixes look strange. Laconian antefixes were normally of the semicircular type, with a well-marked center and decoration

²⁸ Kourouniotes (footnote 21 above), p. 276 and p. 277, fig. 4.

²⁹ Le Roy, 1967, p. 90, A.185, pl. 31. The fragment is not Laconian and is not even clearly an antefix. Le Roy dates it to the end of the 7th century B.C. without excluding the possibility that the type was perpetuated in the first part of the 6th century. There is also a sima fragment from Delphi with heraldic sphinxes.

³⁰ H. Koch, *Dachterrakotten aus Campanien*, Berlin 1912, pl. 12:3.

³¹ *Korkyra I*, p. 135, fig. 107. Two broken antefixes are in the museum at Corfu, nos. 447 and 449, labeled "from Artemis temple 6th C."; *GFR*, pl. 21, fig. 68. There is a variant with lions replacing the sphinxes.

³² P. Lemerle, "Chronique des fouilles (1934)," *BCH* 59, 1935 (pp. 234–309), pp. 293, 296–297, and pl. XVIII.

³³ This series of antefixes was arranged for the author's paper, "Early Development of the Corinthian Antefix" (84th General Meeting of the Archaeological Institute of America, Philadelphia, 1982, abstract *AJA* 87, 1983, p. 230) and "The Development of the Corinthian Antefix" in N. Cooper, 1983, pp. 52–73.



FIG. 18. Bassai, reconstruction of eaves, cover tile, and ridge cover

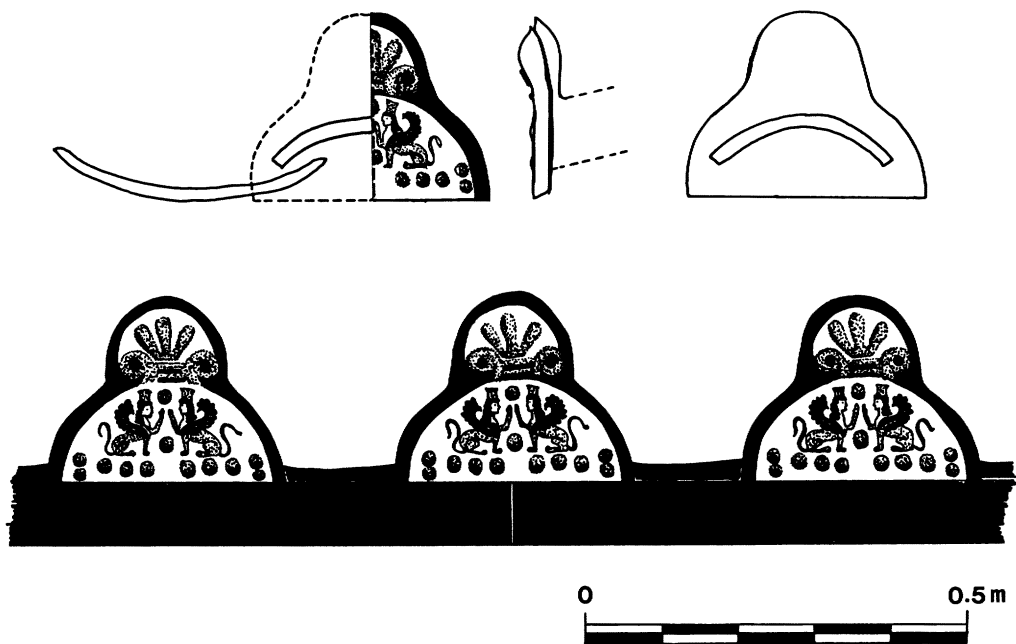

FIG. 19. Bassai, reconstruction of eaves

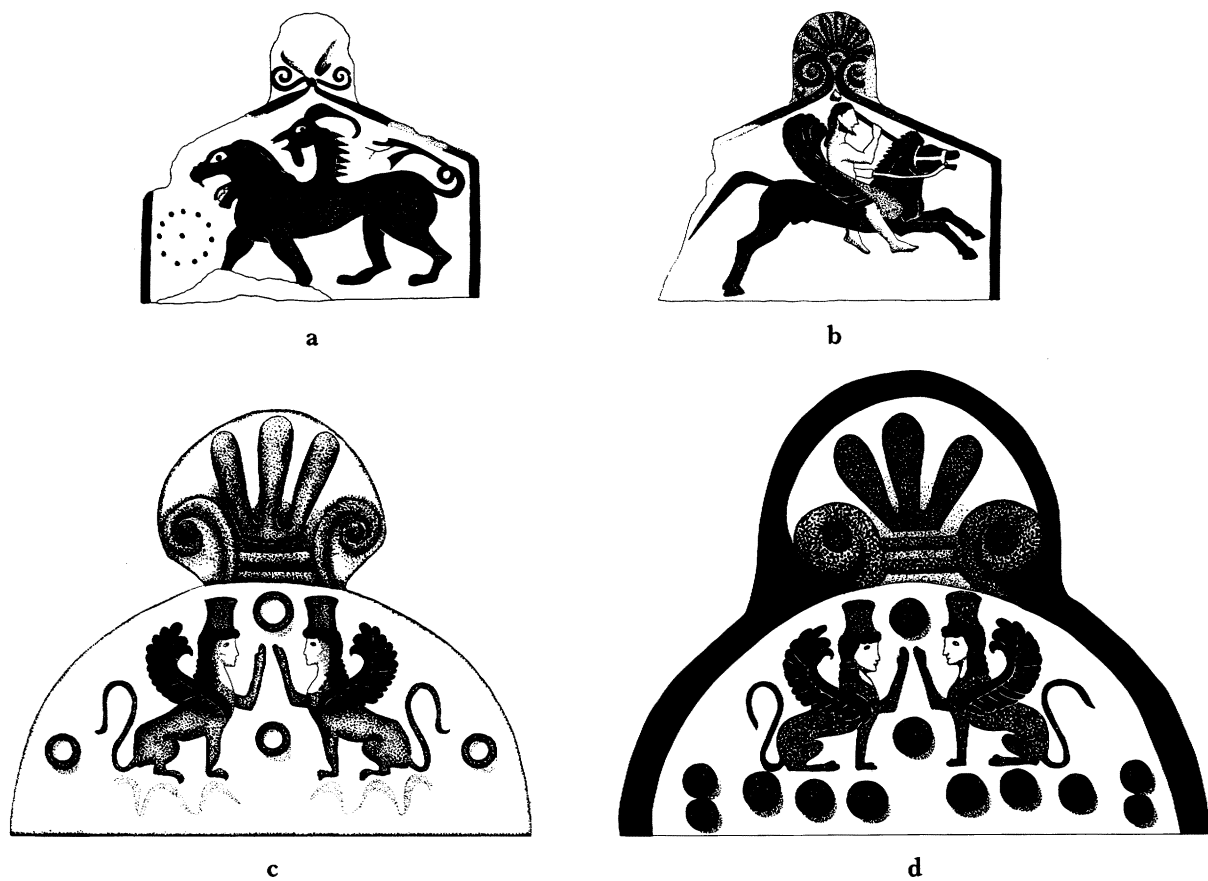
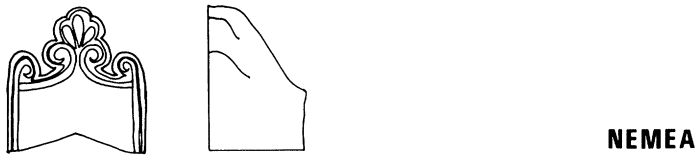
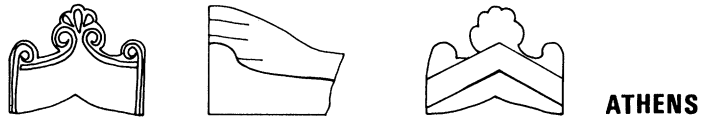

FIG. 20. a, b: Thasos, two Corinthian antefixes. c, d: Bassai, "A" and "B" antefixes. Scale 1:5



ANTEFIXES



FIG. 21. Early palmette antefixes

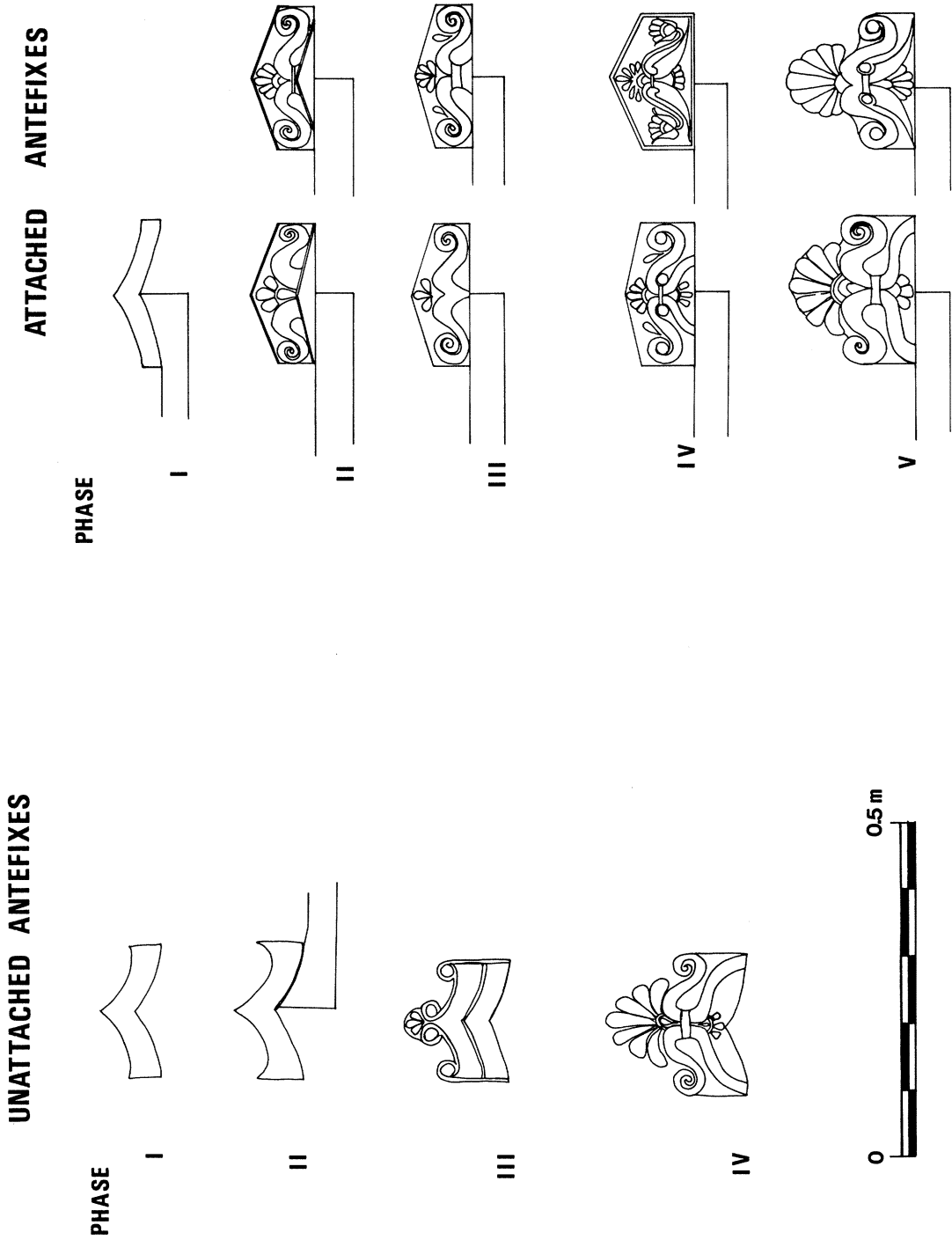

FIG. 22. Development of the antefix

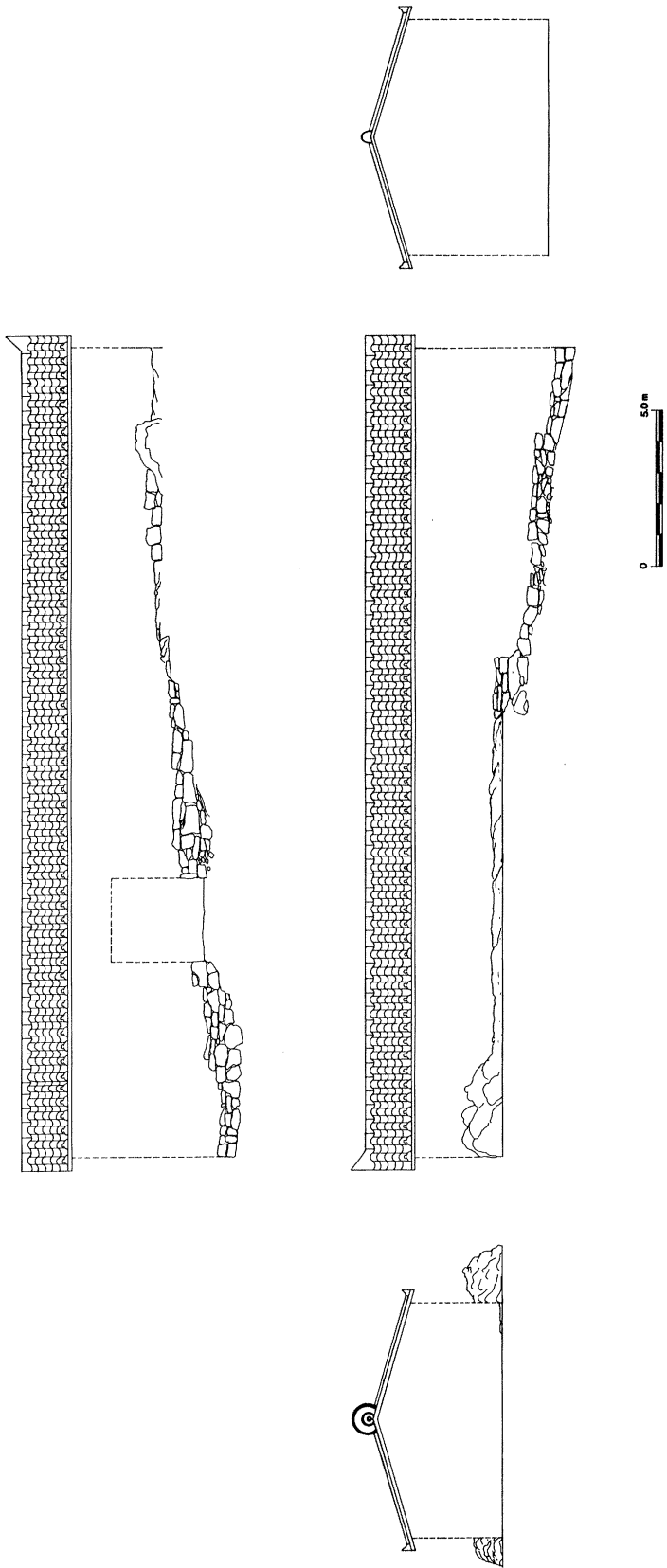

FIG. 23. Bassai, Archaic Temple of Apollo, reconstruction

of concentric zones or radiating patterns. The antefix of the Heraion at Olympia has raised molded decoration, a further development of earlier designs incised and painted on a flat surface. The only element of the decoration on the Bassai antefix that even remotely resembles these patterns is the placement of one of the wreaths or spheres marking the center. The palmette at the top completely changes the semicircular shape. The Bassai antefix looks like a Laconian antefix disguised as Corinthian. It must come near the end of the period when the Laconian-style roof was used on temples and between phases III and IV on the left side of the chart of antefix development in Figure 22.

The original surfaces of the “A” tiles are well preserved; the “B” tiles appear worn by comparison. The excellent preservation of the surface and the colors of the “A” tiles suggests that they were not on the roof long enough to undergo severe weathering. The presence of pieces representing two nearly identical but distinct revetments can be explained by the assumption the roof was repaired by replacing only damaged “B” tiles with “A” tiles. This would also account for the weathering of the “B” tiles and the fact that tiles of this type are found at the site in greater numbers than those of type “A”. Both types show the result of burning. Van Buren and Rhomaios claim that roof “A” preceded “B”. Both seem to have based their conclusion only upon the style of disk and antefix fragments, without considering the ratio of type “A” to “B” tiles at the site.³⁴ The “B” roof was the original roof of the Archaic temple, the “A” roof a replacement, most likely of only part of the roof.

The foundations of the temple and surrounding landscape indicate a simple structure with mud-brick walls on a roughly worked stone socle (Fig. 23). Three small (0.30 m. diameter) stone columns were found, none taller than about 0.60 m. The columns have flanges projecting from them, as if they were added to the temple interior when terracotta revetment replaced a lighter roof.³⁵

As has been remarked above, the profiles of pan and cover tiles from Bassai are remarkably similar to those of the Laconian roof at Halieis. The dimensions of the tiles are also similar (Fig. 17). Since the building sizes and the tiles are so similar, the missing element at Bassai, the ridge cover, probably would have been similar to those at Halieis also. The Halieis akroterion disk was about 1.0 m. in diameter, as are the disks from Bassai (Fig. 23).

The architectural terracottas of the Archaic temples at Halieis and Bassai are of special interest because they can be assigned to the foundations of specific buildings. In size and proportion, all three temples are comparable, and all have the same north–south orientation. What little is known about the superstructure of the three buildings is also in agreement.

NANCY K. COOPER

CORNELL UNIVERSITY
Department of Classics
Goldwin Smith Hall 120
Ithaca, NY 14853

³⁴ *GFR*, pp. 18–19. Rhomaios (footnote 23 above), p. 2.

³⁵ See footnote 16 above.



a. Halieis, Roof II: three akroterion-disk fragments. Scale *ca.* 1:2

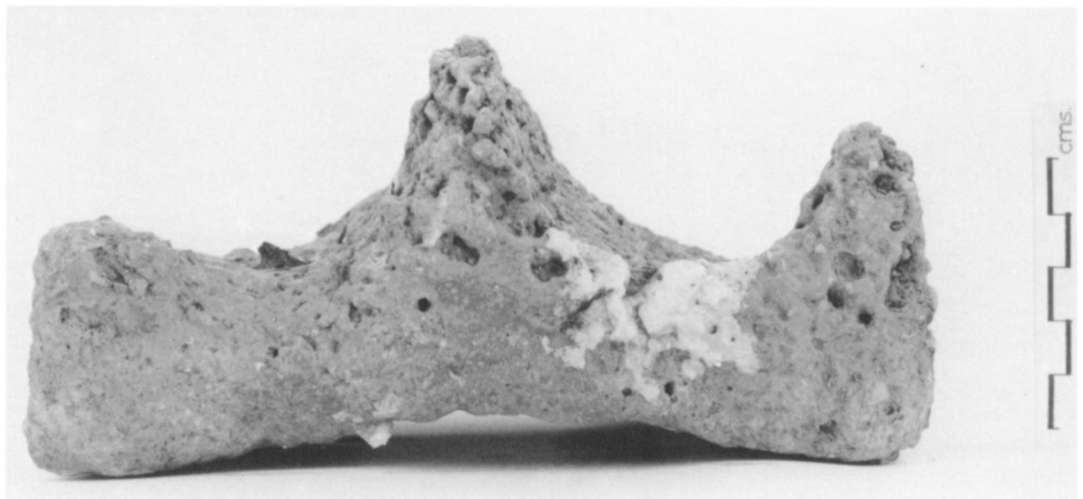

b. Halieis, Temple of Apollo roof: antefix