



Metal contamination in urban, suburban, and country park soils of Hong Kong: A study based on GIS and multivariate statistics

Celine Siu-lan Lee^a, Xiangdong Li^{a,*}, Wenzhong Shi^b,
Sharon Ching-nga Cheung^b, Iain Thornton^c

^aDepartment of Civil and Structural Engineering, The Hong Kong Polytechnic University, Hung Hom, Kowloon, Hong Kong

^bDepartment of Land Surveying and Geo-Informatics, The Hong Kong Polytechnic University, Hung Hom, Kowloon, Hong Kong

^cDepartment of Environmental Science and Technology, Imperial College, London SW7 2AZ, UK

Received 18 March 2005; accepted 21 March 2005

Available online 23 May 2005

Abstract

The urban environment quality is of vital importance as the majority of people now live in cities. Due to the continuous urbanisation and industrialisation in many parts of the world, metals are continuously emitted into the terrestrial environment and pose a great threat on human health. An extensive survey was conducted in the highly urbanised and commercialised Hong Kong Island area (80.3 km²) of Hong Kong using a systematic sampling strategy of five soil samples per km² in urban areas and two samples per km² in the suburban and country park sites (0–15 cm). The analytical results indicated that the surface soils in urban and suburban areas are enriched with metals, such as Cu, Pb, and Zn. The Pb concentration in the urban soils was found to exceed the Dutch target value. The statistical analyses using principal component analysis (PCA) and cluster analysis (CA) showed distinctly different associations among trace metals and the major elements (Al, Ca, Fe, Mg, Mn) in the urban, suburban, and country park soils. Soil pollution maps of trace metals (Cd, Co, Cr, Cu, Ni, Pb, and Zn) in the surface soils were produced based on geographical information system (GIS) technology. The hot-spot areas of metal contamination were mainly concentrated in the northern and western parts of Hong Kong Island, and closely related to high traffic conditions. The Pb isotopic composition of the urban, suburban, and country park soils showed that vehicular emissions were the major anthropogenic sources for Pb. The ²⁰⁶Pb/²⁰⁷Pb and ²⁰⁸Pb/²⁰⁷Pb ratios in soils decreased as Pb concentrations increased in a polynomial line (degree=2).

© 2005 Elsevier B.V. All rights reserved.

Keywords: Urban soil; Heavy metals; Multivariate statistic; GIS; Pb isotope; Hong Kong

* Corresponding author. Tel.: +852 2766 6041; fax: +852 2334 6389.

E-mail address: cexdli@polyu.edu.hk (X.D. Li).

1. Introduction

With the increasing demand for metals in industries and rapid urbanisation in many parts of the world, contamination by metals in the terrestrial environment has become widespread in a global context. Increasing metal pollution has severely disturbed the natural geochemical cycling of the ecosystem. Heavy metals from vehicular emissions, incinerators, industrial waste, the atmospheric deposition of dust and aerosols, and other activities have continuously added to the pool of contaminants in the environment (Harrison et al., 1981; Culbard et al., 1988; Thornton, 1991; Schuhmacher et al., 1997; Hashisho and El-Fadel, 2004; Kuang et al., 2004; Mireles et al., 2004; Banat et al., 2004). Hong Kong is an urban metropolis with a population of over 6.8 million and a small land area of only 1067 km² (for population density of about 6300 people per km²). Many residential areas and commercial skyscrapers have been built in the close vicinity of well-established networks of highways and roads. Situated in the southern tip of the Pearl River Delta Region (PRDR) that has rapidly industrialised in the last three decades, Hong Kong is also susceptible to regional pollution from the PRDR (Wang et al., 2003; Wong et al., 2003). Metal contamination from various sources is an important environmental concern in Hong Kong.

Due to the non-biodegradability of heavy metals and their long biological half-lives for elimination, their accumulation in the food chain will have a significant effect on human health in the long term (Alloway, 1990; Kabata-Pendias and Pendias, 1992). Past studies have revealed that human exposure to high concentrations of heavy metals will lead to their accumulation in the fatty tissues of the human body and affect the central nervous system, or the heavy metals may be deposited in the circulatory system and disrupt the normal functioning of the internal organs (Nriagu, 1988; Thompson et al., 1988; Waisberg et al., 2003; Bocca et al., 2004). A number of studies have indicated that children exposed to contaminated soils, dust, and air particulates may ingest a significant amount of toxic elements through the hand–mouth pathway and through other routes of exposure (Davies et al., 1990; Mielke et al., 1999; Raghunath et al., 1999; Yáñez et al., 2003).

The distribution of heavy metals in soils has been widely studied in Hong Kong (Wong and Tam, 1978; Lau and Wong, 1982; Chen et al., 1997; Li et al., 2001). Some attempts have also been made in Hong Kong (Li et al., 2004) and other areas (Tao, 1995; Mielke et al., 2000; Facchinelli et al., 2001; Norra et al., 2001; Romić and Romić, 2003) to study the distribution of metals in soils and their sources using GIS methods. However, the enrichment of heavy metals in soils in urban areas compared with the situation in industrial or mining areas is not well illustrated. Studies on the sources of pollution using GIS have also mainly been limited to the mapping of soil pollutants/pollution indices and direct comparisons between them and various thematic maps (such as roads, topography, and buildings) within different GIS layers. The quantitative correlation between heavy metals in soils and their potential sources has also not been well established in urban surroundings. The aims of the present study are (1) to assess and compare metal contamination in soils of urban, suburban, and country park areas of Hong Kong; (2) to evaluate the relationship between heavy metals and their possible sources using GIS spatial analysis; and (3) to identify the anthropogenic sources of Pb using Pb isotopic composition analysis.

2. Materials and methods

2.1. The study area

Hong Kong is comprised of three geographical areas, namely Hong Kong Island, the Kowloon Peninsula, and the New Territories. Hong Kong Island and the Kowloon Peninsula are old urban areas of Hong Kong with a long history as city centres. The development of the New Territories commenced in the 1970s, and new towns were developed to decentralise the population from the main urban districts (Hong Kong Island and Kowloon Peninsula). In recent years, reclamation has been carried out in Western Kowloon and the north shore of Hong Kong in order to construct a strategic transport link, and to develop residential and commercial areas (Information Services Department, 2004). Hong Kong's industry underwent major restructuring in the 1980s and early 1990s.

Most of the manufacturing industries have been relocated to the Chinese mainland.

2.2. Soil sampling

In this study, the scope of the sampling area was focused on Hong Kong Island, which has an area of 80.28 km². A systematic sampling strategy was adopted to provide a sampling programme over the entire island (Fig. 1). The whole area was divided into 80 cells of 1 km × 1 km in size, within which the topsoils (0–15 cm) were collected. In the sampling programme, soils from urban, suburban, and country park areas were collected based on the different site conditions (see Table 1). A sampling density of 5 samples per km² was adopted wherever possible in urban areas, and 2 samples per km² was used in both the suburban areas and inside the country parks. Each of the soil samples consisted of 9 sub-samples

Table 1

Site description of the sampling sites of urban, suburban, and country park soils

Type of soils	Site description
Urban soils	Collected at locations where there is a high density of buildings and roads
Suburban soils	Collected from areas surrounding the country parks that are away from highly urbanised areas but are accessible by road
Country park soils	Collected inside country parks that are not accessible by road and that are at least 50 m away from roads

obtained in a 2 m × 2 m grid using a stainless steel hand auger. The collected soil samples were stored in polyethylene bags for transport and storage. The soil samples were air-dried in an oven at 50 °C for 3 days. They were then sieved through a 2.0-mm polyethylene sieve to remove stones, coarse materials, and

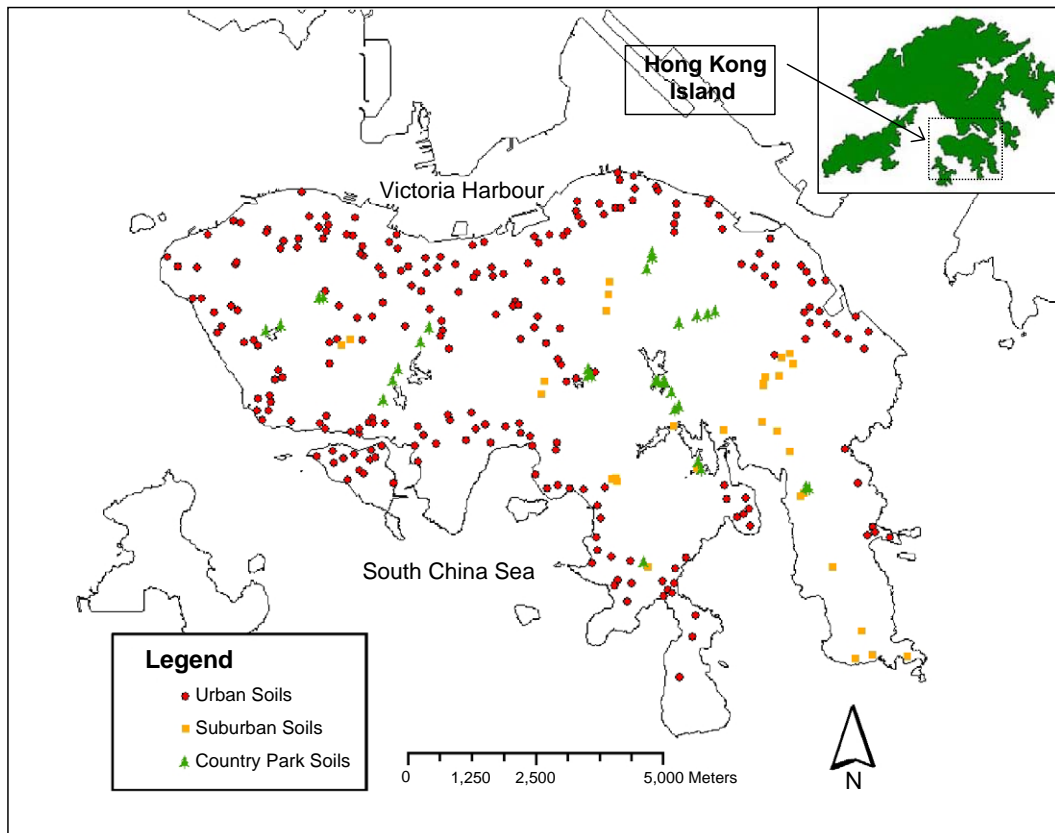

Fig. 1. Sampling locations of urban, suburban, and country park soils on Hong Kong Island.

other debris. Portions of the soil samples (~20 g) were ground in a mechanical agate grinder until fine particles (<200 µm) were obtained. The prepared soil samples were then stored in polyethylene bags in a desiccator.

2.3. Rock sampling

Three major types of bedrock in Hong Kong, including granite, granodiorite and tuff, were sampled. A total of 9 samples were collected (3 samples for each type of rock) at various locations of Hong Kong using a stainless steel hammer. Portions of the rock samples were then ground using mechanical agate grinder to fine particles (<200 µm). The ground rock samples were then stored in a polyethylene bags in a desiccator before analysis.

2.4. Strong acid digestion

The soil samples were analysed for major and trace metal concentrations using a strong acid digestion method (Wong and Li, 2004). Approximately 0.200 g of the soil samples were weighed and placed into pre-cleaned Pyrex test tubes. About 8.0 ml of concentrated nitric acid and 2.0 ml of concentrated perchloric acid were added to the tubes inside the fume hood. The concentrated nitric and perchloric acid were handled with caution. Protective robe and gloves were put on when concentrated acids were used. The mixtures were heated in an aluminium block at 50 °C for 3 h, 75 °C for 1 h, 100 °C for 1 h, 125 °C for 1 h, 150 °C for 3 h, 175 °C for 2 h, and 190 °C for 3 h until they were completely dry. After the test tubes were cool, 10.0 ml of 5% HNO₃ were added and heated at 70 °C for 1 h with occasional mixing. Upon cooling, the mixtures were decanted into polyethylene tubes and centrifuged at 1230 × g for 10 min. Metal concentrations of the solutions were measured using Inductively Coupled Plasma-Atomic Emission Spectrometer (ICP-AES; Perkin Elmer 3300DV). The major elements that were determined were Al, Ca, Fe, Mg, and Mn, while trace metals included Cd, Co, Cu, Cr, Ni, Pb, and Zn. For quality control, reagent blanks, replicates, and standard reference materials (NIST SRM 2709 San Joaquin Soil and an internal reference material), representing 10%, 20%, and 10% of the total sample

population, respectively, were incorporated in the analysis to detect contamination and to assess precision and bias. The analytical results showed no signs of contamination and that the precision and bias of the analysis were generally <10%. The recovery rates for most of the heavy metals and major elements in the international standard reference material (NIST SRM 2709) were around 80% to 95%. The recovery rates for Al, Pb, and Cr were around 60% in the reference material due to their low concentrations and the presence of aluminosilicate minerals.

Approximately 0.300 g of the ground rock samples (<200 µm) were digested in similar settings using the strong acids (concentrated nitric and perchloric acids). Elemental concentrations of the solutions were then determined using ICP-AES (Perkin Elmer 3300DV). The precision and bias assessed by the reagent blanks and replicate samples were <10% for both trace and major elements in the analysis.

2.5. Pb isotopic composition analysis

The Pb isotopic composition analysis was performed on selected soil samples from the urban, suburban, and country park areas, and the rock samples to study the natural and anthropogenic origins of Pb in the three types of soils and the natural bedrocks. Solutions from the strong acid digestion were diluted until a Pb concentration of about 20 ppb was obtained, using 5% high-purity HNO₃ and analysed for Pb isotopic composition by Inductively Coupled Plasma-Mass Spectrometer (ICP-MS; Perkin-Elmer Elan 6100 DRC^{plus}). The analytical parameters were set as 190 sweeps/reading, one reading/replicate, and 10 replicates per sample solution. Dwell times of 40, 25, 25, and 25 ms were used for ²⁰⁴Pb, ²⁰⁶Pb, ²⁰⁷Pb, and ²⁰⁸Pb, respectively. The Pb counts of the procedural blank were below 0.5% of the samples. The relative standard deviations (RSD) of the 10 replicates were generally below 0.5%. A standard reference material (NIST SRM981 Common Pb Isotopic Standard) was used for quality control. The measured Pb ratios of ²⁰⁴Pb/²⁰⁷Pb, ²⁰⁶Pb/²⁰⁷Pb, and ²⁰⁸Pb/²⁰⁷Pb were 0.0645 ± 0.0001, 1.0938 ± 0.0011, and 2.3710 ± 0.0030, which were in good agreement with the standard reference values of 0.0645, 1.0933, and 2.3704, respectively.

2.6. Statistical analysis

The analytical results and field data were compiled to form a multi-elemental database using Excel and SPSS®. Statistical analyses, including principal component analysis (PCA) and cluster analysis (CA), were performed using SPSS® statistical software. In the PCA, the principal components were calculated based on the correlation matrix. Varimax with Kaiser normalisation was used as the rotation method in the analysis. Since the elemental concentrations varied greatly among the major and trace elements, the raw data were standardised before the execution of clustering in CA. The data were standardised to the Z score (with a mean of 0 and a standard variation of 1) and then classified using the Ward's method. The distance measure used in CA was the Squared Euclidean distance. The heavy metals, which showed a close correlation, were identified and grouped for further analysis.

2.7. Spatial analysis based on GIS

The heavy metal concentrations were used as the input data for soil pollution maps to study the distribution of metals in urban soils. The software used for the mapping and spatial analysis was Arcview 8.3. An interpolation method called the Inverse Distanced Weighted (IDW) method was adopted for the interpolation of geographical data. Gridding was performed based on a grid size of 50 × 50 m² using all of the input points available with a variable search radius. In the IDW method, the closer a point is to the centre of the cell being estimated, the more weight it has in the averaging process. The heavy metals, which are highly enriched in urban and suburban soils as compared with country park soils, were identified. A soil pollution index (SPI) was then calculated at each location by dividing the heavy metal concentrations of the samples with the Dutch target concentrations of the specific highly elevated heavy metals, and then averaging the results by the number of trace elements:

$$\text{SPI}_i = \frac{\sum_j \frac{\text{MC}_i}{\text{TC}_j}}{N}$$

where: i =sampling locations; j =the heavy metals that are highly enriched; MC_i =the metal concentrations at i th sampling location; TC_j =the target concentrations of j th heavy metal that are highly enriched, and N =the number of heavy metals that are highly enriched. The calculated SPI was then interpolated to give an index map of metal contamination in the soils. A map of traffic data (Annual Average Daily Traffic—AADT) was also constructed based on the data in the traffic census (Transport Department, 2002). A three-dimensional view of the map of the soil pollution index was also formed and overlaid with the thematic map of AADT to provide better visualisation of the metal pollution and to study the relationship between metal enrichment in soils and the related traffic volumes.

3. Results and discussion

3.1. Heavy metal concentrations

The concentrations of Cd, Co, Cr, Cu, Ni, Pb, and Zn in the urban, suburban and country park soils in Hong Kong Island are summarised in Table 2. The mean concentration of Pb in the HKI urban soils (88.1 mg/kg) exceeded the target values recommended by the Netherlands Soil Contamination Guidelines (Department of Soil Protection, 1994) (85 mg/kg) and the mean Zn concentration (103 mg/kg) was close to the Dutch target value (140 mg/kg). The mean concentrations of Cd, Co, Cr, Cu, Ni, Pb, and Zn in the suburban and country park soils were generally below the target values. The major and trace elemental concentrations of three types of major bedrock in Hong Kong, granite, granodiorite, and tuff, were also analysed in the present study and the results are given in Table 3. In comparison with the background values, represented by the natural bedrock, the urban soils and suburban soils were enriched with metals such as Cu, Pb, and Zn. The trace metal concentrations of the country park soils were comparable to the background values. The heavy metal concentrations in the urban soils were generally higher than those in suburban soils, because more anthropogenic activities took place in urban environments.

Table 2

Heavy metal concentrations (mg/kg) in the urban, suburban and country park soils collected on Hong Kong Island and the target values (mg/kg) from the Netherlands soil contamination guidelines

Location		Cd	Co	Cr	Cu	Ni	Pb	Zn
Urban soil ^a (<i>n</i> = 236)	Range	0.11–1.36	0.60–10.9	2.56–51.4	1.30–277	0.24–19.9	7.53–496	23.0–930
	Mean	0.36	3.55	17.8	16.2	4.08	88.1	103
	Median	0.33	3.33	16.8	10.4	3.65	70.6	78.1
	S.D.	0.16	1.57	5.92	22.6	2.51	62.0	91.3
Suburban soil ^a (<i>n</i> = 31)	Range	0.23–0.80	1.71–16.3	10.1–49.2	1.39–89.0	1.25–6.78	15.8–161	25.5–173
	Mean	0.37	3.72	20.8	9.72	3.54	57.8	67.9
	Median	0.31	2.91	19.7	4.93	3.11	49.4	52.0
	S.D.	0.15	2.85	8.60	16.1	1.54	31.0	40.0
Country Park soil ^a (<i>n</i> = 31)	Range	0.20–0.58	1.35–8.11	13.7–47.6	1.99–20.2	1.77–9.62	11.2–124	25.3–136
	Mean	0.35	3.04	21.8	6.37	5.30	39.6	46.8
	Median	0.32	2.67	20.2	4.84	4.82	36.5	43.6
	S.D.	0.09	1.41	6.70	4.02	2.00	23.3	21.5
Urban soil ^b (Kowloon; <i>n</i> = 152)	Mean	0.62	3.33	23.1	23.3	12.4	94.6	125
Dutch soil guidelines ^c	Target value	0.8	20	100	36	35	85	140
	Intervention value	12	240	380	190	210	530	720

^a The present study.

^b Li et al. (2004).

^c Department of Soil Protection, Netherlands (1994).

3.2. Results of multivariate statistics

3.2.1. Principal component analysis (PCA)

The results of PCA for the metal concentrations in the urban, suburban, and country park soils are tabulated in Table 4. Four principal components were considered in the PCA analysis, accounting for over 80% of the total variance in the three sets of data.

In the HKI urban soils, elements such as Cd, Cu, Ni, Pb, and Zn were closely associated in the first principal component (PC1), which explained over 30% of the total variance. This may indicate the influence of anthropogenic inputs of these elements into the urban soils. Cobalt was found to be associated with Mg and Mn in the PC1 of the suburban soils, and elements such as Cd, Cr, and Ni were associated with Al and Fe in the PC1 of the country park soils, which explained over 25% and 30% of the total variance, respectively. These results showed that the heavy metals in the suburban and country park soils were found to be associated with some rock-forming elements, which may originate from the parental materials of the soils. In urban soils, metal enrichments resulted from different sources of input, particularly

anthropogenic activities. The first principal component accounted for most of the variability in the data, and each succeeding component accounted for a reduced percentage of the remaining variability. Hence, anthropogenic activities were shown to be the dominant influence on urban soils, while natural sources and, to some extent, anthropogenic activities were shown to have a strong influence on the suburban and country park soils.

The rotated component matrix showed that Cr was mainly associated with Fe and Mg in the second component (PC2) and Co and Mn in the third component (PC3) of the HKI urban soils, suggesting a natural origin from parent rocks. Similarly, strong

Table 3

Concentrations (mg/kg) of major and trace elements of natural bedrocks in Hong Kong

Rock type		Cd	Co	Cr	Cu	Ni	Pb	Zn
Granite (<i>n</i> = 3)	Mean	< 0.30	1.65	13.0	2.04	5.82	7.41	27.3
	S.D.		1.51	2.80	2.64	6.14	3.94	9.34
Granodiorite (<i>n</i> = 3)	Mean	< 0.30	7.61	32.8	2.87	13.4	15.4	92.9
	S.D.		5.67	11.3	3.58	13.9	4.03	28.8
Tuff (<i>n</i> = 3)	Mean	< 0.30	5.27	26.5	2.79	5.08	16.1	55.1
	S.D.		2.64	8.44	3.36	2.16	10.1	31.4

Table 4

Matrix of the principal component analysis loadings of heavy metals and major elements of urban soils on Hong Kong Island

	Principal component											
	Urban soils (<i>n</i> =236)				Suburban soils (<i>n</i> =31)				Country Park soil (<i>n</i> =31)			
	PC1	PC2	PC3	PC4	PC1	PC2	PC3	PC4	PC1	PC2	PC3	PC4
Al	-0.067	0.227	-0.075	-0.805	-0.031	<i>0.938</i>	-0.079	0.076	<i>0.851</i>	-0.309	0.033	-0.152
Ca	0.236	0.290	-0.100	<i>0.703</i>	0.005	0.103	<i>0.904</i>	-0.033	-0.070	0.069	-0.028	<i>0.904</i>
Cd	<i>0.822</i>	0.363	0.023	0.162	0.598	0.357	<i>0.648</i>	0.111	<i>0.663</i>	0.591	-0.041	0.024
Co	0.120	0.548	<i>0.648</i>	-0.115	<i>0.897</i>	0.241	-0.037	0.075	0.100	0.352	<i>0.896</i>	-0.002
Cr	0.632	<i>0.658</i>	-0.095	-0.049	0.473	<i>0.770</i>	0.279	-0.165	<i>0.942</i>	0.119	-0.161	-0.008
Cu	<i>0.891</i>	0.111	-0.046	0.129	0.069	-0.012	0.144	<i>0.956</i>	0.274	<i>0.726</i>	0.264	0.142
Fe	0.232	<i>0.828</i>	0.063	-0.232	0.571	<i>0.710</i>	0.150	-0.160	<i>0.894</i>	0.098	-0.169	0.134
Mg	-0.037	<i>0.853</i>	0.157	0.303	<i>0.784</i>	0.394	0.216	0.068	0.087	0.126	0.064	<i>0.909</i>
Mn	-0.030	0.017	<i>0.910</i>	0.055	<i>0.814</i>	-0.0442	0.223	-0.090	-0.123	0.225	<i>0.919</i>	0.033
Ni	<i>0.749</i>	0.416	-0.191	0.060	0.008	<i>0.667</i>	0.438	0.075	<i>0.757</i>	0.007	0.287	0.021
Pb	<i>0.777</i>	-0.201	0.384	-0.070	0.509	0.007	0.402	0.178	-0.261	<i>0.774</i>	0.378	0.036
Zn	<i>0.915</i>	0.098	0.053	0.207	0.290	0.073	<i>0.742</i>	0.211	-0.032	<i>0.900</i>	0.184	0.118

The italicized numbers are the dominant elements in different PCs.

associations were also observed between Co and Mn in the suburban and country park soils. Calcium was univocally isolated in the fourth component (PC4) of the HKI urban soils and showed a weak association with other elements. In general, PC2, PC3, and PC4 in the rotated component matrix of the suburban and country park soils depicted the natural geochemical associations of elements in soils derived from their parental materials.

3.2.2. Cluster analysis (CA)

Cluster analysis was performed on the elemental concentrations in the urban, suburban and country park soils. The results are illustrated in the dendrograms (Figs. 2–4). The distance cluster represents the degree of association between elements. The lower the value on the distance cluster, the more significant was the association. A criterion for the distance cluster of between 15 and 20 was used in the analysis.

*** H I E R A R C H I C A L C L U S T E R A N A L Y S I S ***

Dendrogram using Ward Method

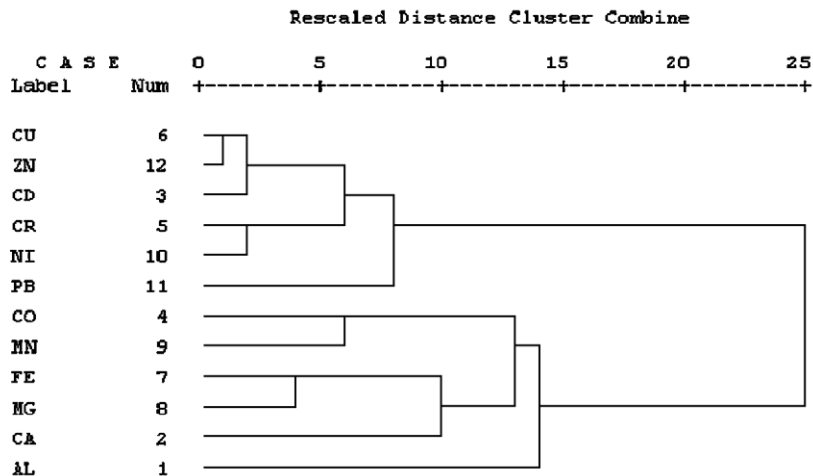

Fig. 2. Dendrogram of the cluster analysis of the HKI urban soils based on their total metal concentrations (*n*=236).

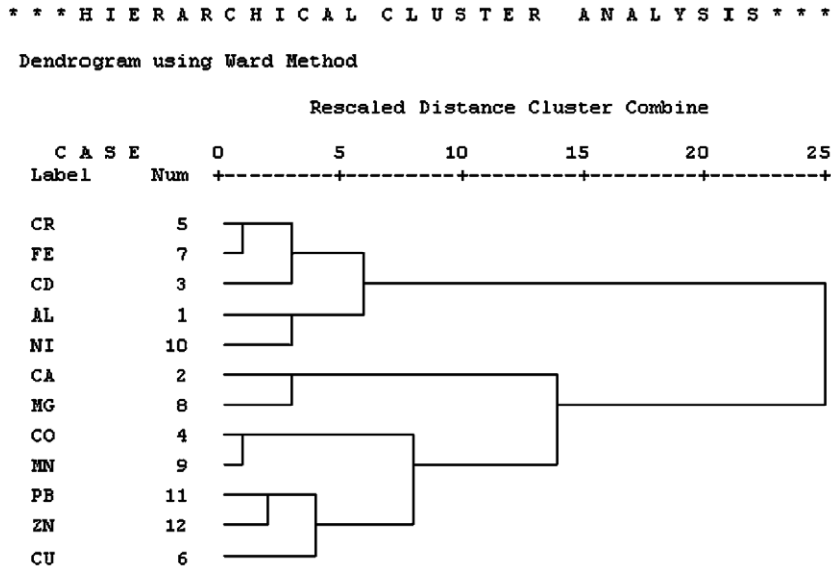

Fig. 4. Dendrogram of the cluster analysis of the country park soils based on their total metal concentrations ($n=31$).

distance cluster of about 8. This suggested the association between these elements was very significant. Only Co was found to be associated with the major elements in the urban soils, especially with Mn, at a distance cluster of about 7 (see Fig. 2). The clusters in the suburban soils showed that heavy metals were associated with the major elements (see Fig. 3). However, the clustering pattern of elements was less distinct in the suburban soils. The associations between the heavy metals and major rock-forming elements may reflect both anthropogenic and natural inputs in the soils.

In general, the results of CA agreed well with that of the PCA. The differences between the HKI urban soils and country park soils were well illustrated in both analyses. The anthropogenic inputs in the urban environment caused significant enrichments of heavy metals, such as Cd, Cr, Cu, Ni, Pb, and Zn in the soils. Therefore, the original associations of these elements with major elements derived from their natural sources were altered, demonstrating a different clustering pattern in these soils.

3.3. GIS based analyses

3.3.1. Spatial distribution of trace metals

The soil pollution maps of heavy metals including Cd, Co, Cr, Cu, Ni, Pb, and Zn were generated

using GIS. The results of the selected elements are shown in Fig. 5. The spatial distributions of metals such as Cd, Cu, Pb, and Zn in soils were similar. In fact, they were strongly correlated in the statistical results for the urban and suburban soils. Cadmium, Cu, Pb, and Zn in the soils may originate from similar sources and most probably from anthropogenic inputs. Previous studies have revealed that metal contamination in Hong Kong is significantly related with traffic and its related activities (Lau and Wong, 1982; Li et al., 2004). Traffic emissions and other human activities may be a common source governing the distribution of Cd, Cu, Pb, and Zn in soils. Moreover, the spatial distribution of Co (see Fig. 5) was distinctly different from the trace elements such as Cd, Cu, Pb and Zn. High concentrations of Co were mainly found in the western and southern Hong Kong Island, which may attribute to the inputs from natural sources.

As discussed above, the urban and suburban soils of Hong Kong Island were highly enriched with metals, including Cu, Pb, and Zn. These three metals were therefore used to calculate the soil pollution index (SPI), which represents the overall degree of metal pollution in soils. The calculated data was used to form the map of the soil pollution

index (see Fig. 6). The northern and western parts of Hong Kong Island were found to be more polluted than the other parts of the study area, with $SPI > 1$. This result indicated that the soils in

these areas contain elevated concentrations of Cu, Pb, and Zn that exceed the Dutch target values (36 mg/kg, 85 mg/kg, and 140 mg/kg for Cu, Pb, and Zn, respectively). In particular, in Wan Chai, a

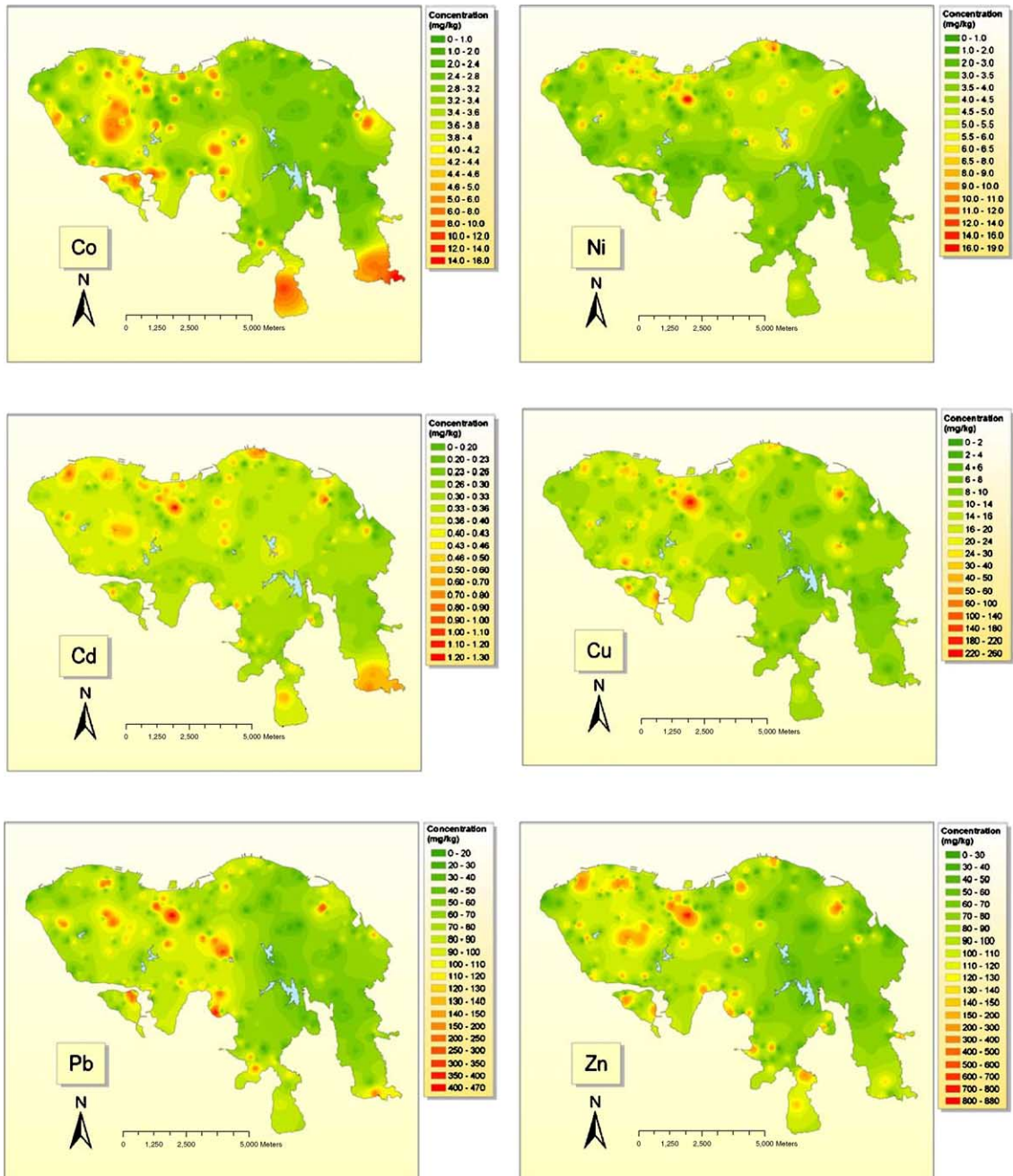

Fig. 5. The soil pollution maps of Co, Ni, Cd, Cu, Pb, and Zn in urban, suburban, and country park soils of Hong Kong Island.

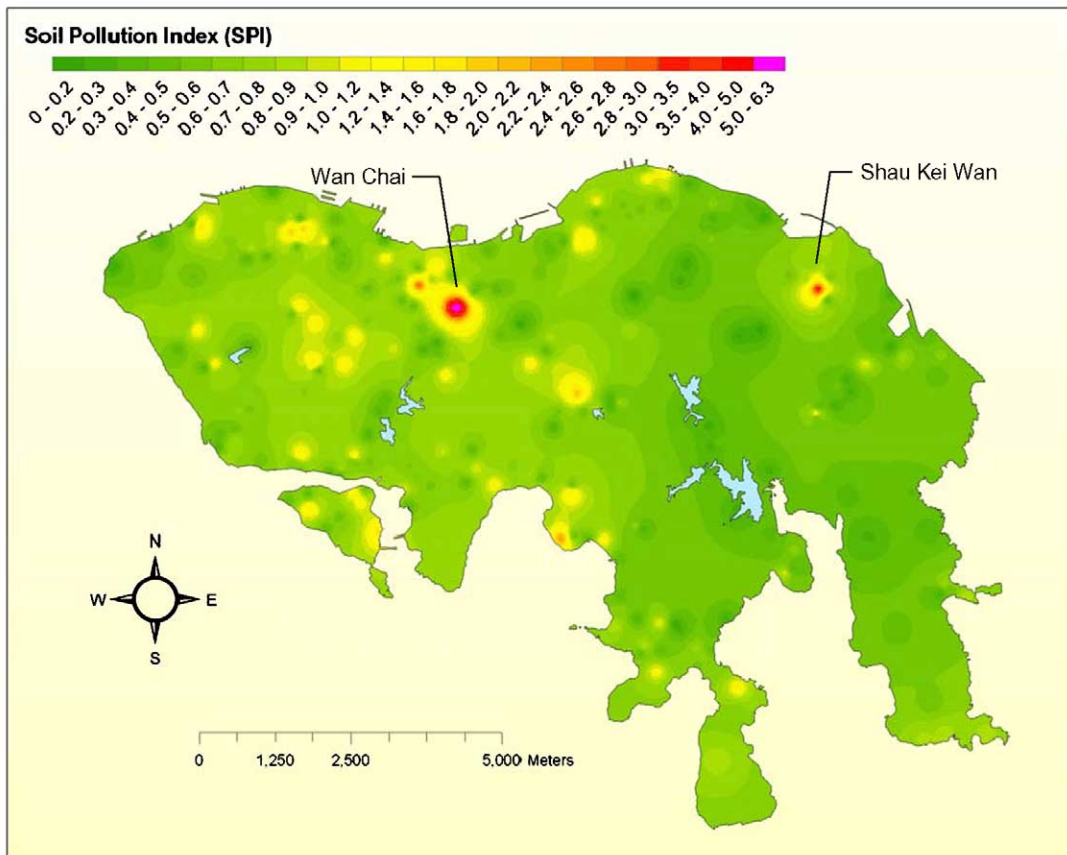

Fig. 6. Map of the soil pollution index.

crowded old residential and commercial area in Hong Kong, the SPI value of 6.7 was almost seven times that of the target values. At Shau Kei Wan, an old residential and commercial area, the SPI value of 3.4 was more than three times that of the target values. Other hot-spot areas with SPI values ranging from 1 to 2 were widely distributed in the northern and western parts of Hong Kong Island (see Fig. 6). The southeastern part of Hong Kong Island was less contaminated with heavy metals, probably because the area has lower population density with little traffic and few industrial activities.

3.3.2. Spatial analysis of the soil pollution index with AADT

The Annual Average Daily Traffic (AADT) data of major and minor roads in Hong Kong Island

was interpolated using GIS and presented in a thematic map (Fig. 7). Three zones of high traffic areas can be identified in Hong Kong Island, including the northern shoreline stretching from Sheung Wan to Causeway Bay, the northeastern corner near Tai Koo Shing and Shau Kei Wan, and the southwestern area near Aberdeen and Wong Chuk Hang. The Annual Average Daily Traffic (AADT) in all of these areas was over 40,000 vehicles. To further investigate the effect of traffic on the trace metal contamination in soils, the contour map of traffic volume (AADT) was overlaid on the three-dimensional map of the Soil Pollution Index (Fig. 8). Some of the hot-spot areas as indicated by high Soil Pollution Index values were near the high traffic zones, including Wan Chai (SPI=6.7) and Shau Kei Wan (SPI=3.4). The major roads near the hot-spot at Wan Chai

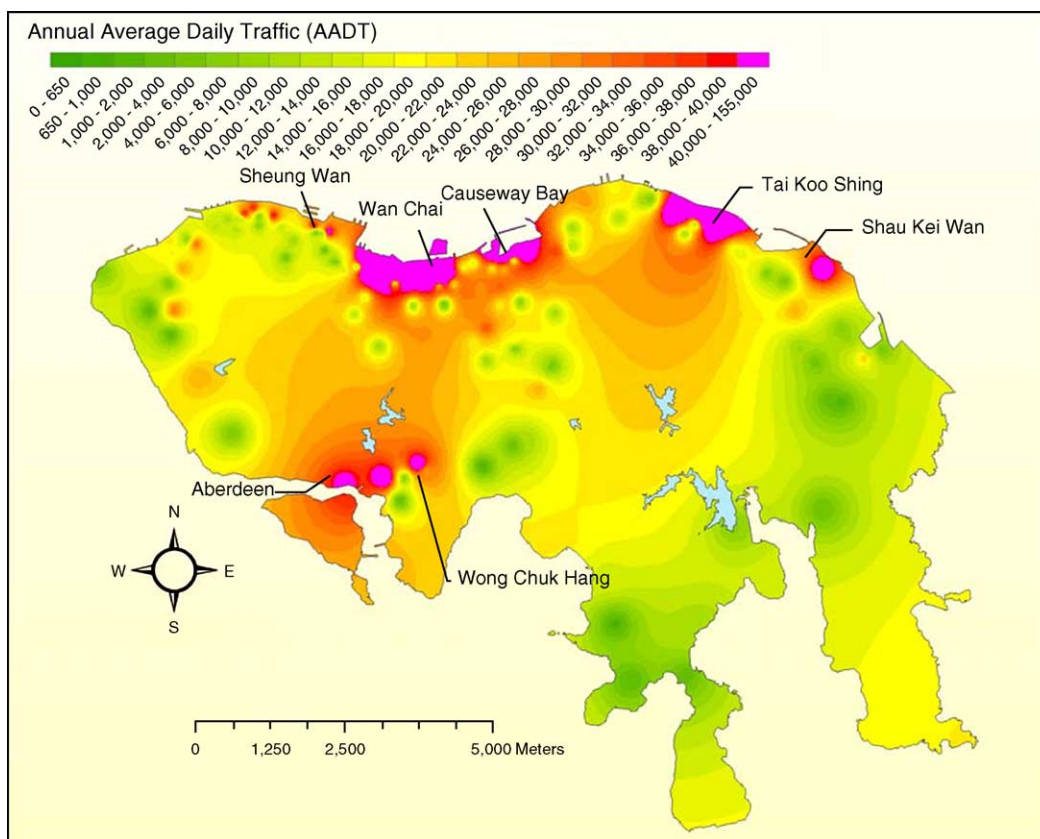

Fig. 7. Map of the annual average daily traffic (AADT).

included Gloucester Road connecting the main cross harbour tunnel (AADT=168,480); and the major expressway, the Island Eastern Corridor (AADT=50,720), was in close vicinity to the hot-spot at Shau Kei Wan. Vehicular emissions from intensive traffic activities contributed mainly to the enrichment of heavy metals in these areas. The effect of wind may have led to the further dispersion of elements such as Cu, Pb, and Zn from these high traffic areas to the surrounding areas through atmospheric deposition.

3.4. Pb isotopic composition analysis

A total of 30 samples from the urban, suburban, and country park soils were analysed for their Pb isotopic compositions. The Pb isotopic ratios ($^{204}\text{Pb}/^{207}\text{Pb}$, $^{206}\text{Pb}/^{207}\text{Pb}$, and $^{208}\text{Pb}/^{207}\text{Pb}$) for selected samples of urban, suburban and country

park soils, and other environmental samples are summarised in Table 5. The mean $^{206}\text{Pb}/^{207}\text{Pb}$ ratios of urban, suburban, and country parks soils were 1.1711, 1.2034, and 1.1996, respectively; and the mean $^{208}\text{Pb}/^{207}\text{Pb}$ ratios of urban, suburban, and country park soils were 2.4608, 2.4927, and 2.4953, respectively. The $^{206}\text{Pb}/^{207}\text{Pb}$ and $^{208}\text{Pb}/^{207}\text{Pb}$ ratios of the urban soils were found to be significantly lower than those of the suburban and country park soils. The Pb isotopic ratios of urban, suburban and country park soils, the natural parent rocks in Hong Kong, the urban dust in Hong Kong, the vehicular exhaust in the Pearl River Delta, and the Australian Pb ore are shown in Fig. 9. The Pb isotopic ratios of the urban, suburban, and country park soils formed a linear line between the natural parent rocks and the known anthropogenic sources ($R^2=0.953$). This implies that the enrichment of Pb in the urban soils of Hong

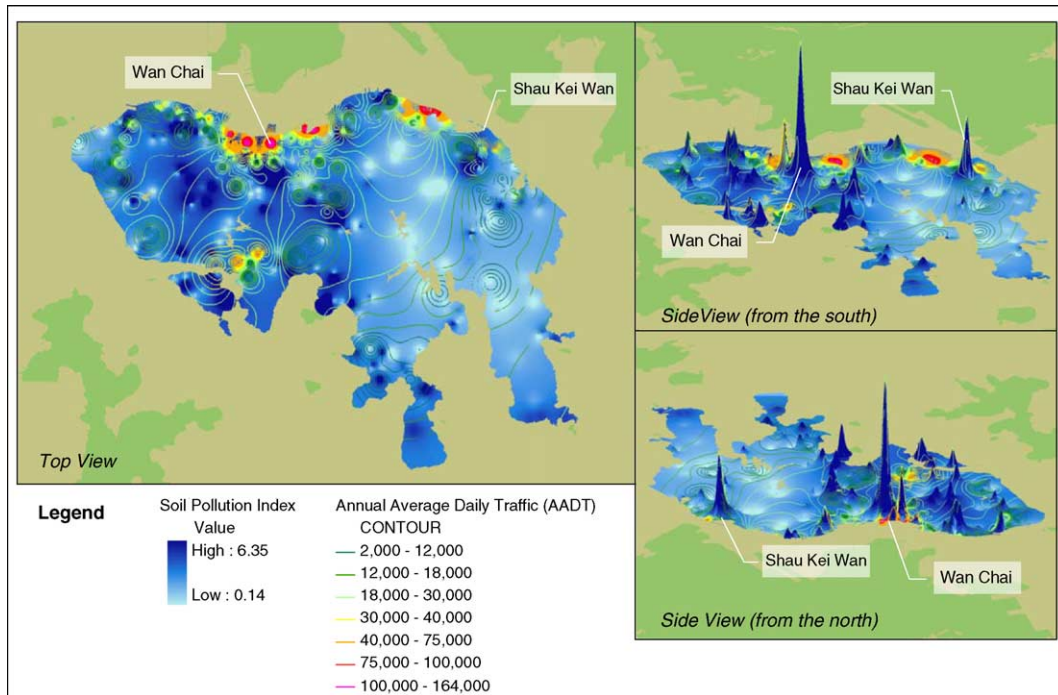

Fig. 8. An overlaid map of the soil pollution index (Cu, Pb, and Zn) and AADT.

Kong Island was probably due to binary mixing between vehicular emissions (i.e., lead additives from Australian ore in the fuel in the past) and geological materials. Similar results were obtained in another study of heavy metal contaminations in the Kowloon urban area of Hong Kong (Li et al.,

2004). Although the use of leaded petrol had been banned in Hong Kong since 1999, the Pb contamination in the urban soils due to the historical use of Pb in petrol was still significant.

Highly contaminated soils were known to have Pb isotopic signatures reflecting their anthropogenic

Table 5

Lead isotopic composition and concentrations of selected urban, suburban, and country park soils on Hong Kong Island and natural bedrock in Hong Kong

Range of Pb conc. (mg/kg)			$^{204}\text{Pb}/^{207}\text{Pb}$	$^{206}\text{Pb}/^{207}\text{Pb}$	$^{208}\text{Pb}/^{207}\text{Pb}$	Pb conc. (mg/kg)
<i>Natural bedrock in Hong Kong</i>						
Tap Mun Island ^a			0.0636	1.2206	2.5291	12
Hok Tsui ^b			0.0636	1.2168	2.5129	14.8
Aberdeen ^b			0.0635	1.2360	2.5914	4.9
<i>Hong Kong Island soils</i>						
Urban soils	>200 (n=4)	Mean	0.0629	1.1101	2.3882	309
	80–100 (n=5)	Mean	0.0638	1.1862	2.4725	90.4
	< 30 (n=5)	Mean	0.0637	1.2048	2.5073	23.7
Suburban soils	30–85 (n=5)	Mean	0.0637	1.2034	2.4927	49.5
Country Park soils	30–85 (n=6)	Mean	0.0635	1.1976	2.4880	60.3
	< 30 (n=5)	Mean	0.0636	1.2021	2.5040	17.6

^a Duzgoren-Aydin et al. (2004).

^b The present study.

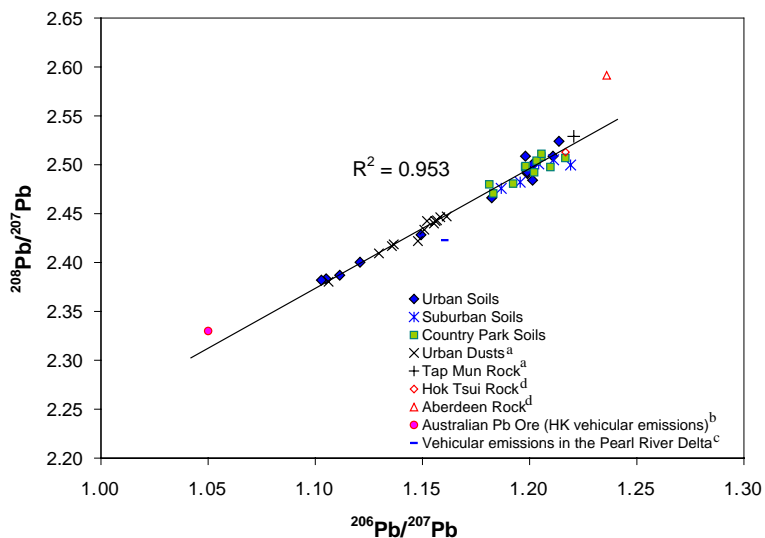

Fig. 9. $^{206}\text{Pb}/^{207}\text{Pb}$ and $^{208}\text{Pb}/^{207}\text{Pb}$ ratios of urban, suburban, and country park soils on Hong Kong Island and other environmental samples. (^aDuzgoren-Aydin et al., 2004; ^bBollhöfer and Rosman, 2001; ^cZhu et al., 2001; ^dThe present study.)

source (Wong and Li, 2004; Li et al., 2004). The Pb isotopic ratios of HKI urban, suburban, and country park soils with different Pb concentrations were plotted in Fig. 10. The $^{206}\text{Pb}/^{207}\text{Pb}$ and $^{208}\text{Pb}/^{207}\text{Pb}$ ratios in the suburban soils were found to be between that of urban soils and country park soils. Of the soils from the three different areas, the urban soils were

found to have the lowest $^{206}\text{Pb}/^{207}\text{Pb}$ and $^{208}\text{Pb}/^{207}\text{Pb}$ ratios, closer to the anthropogenic signature (e.g., vehicle emission sources), while the country park soils had the highest values, resembling that of the natural bedrocks. It was noted that the Pb isotopic ratios of the low contaminated urban soils (<30 mg/kg) were found to be very similar to that of the

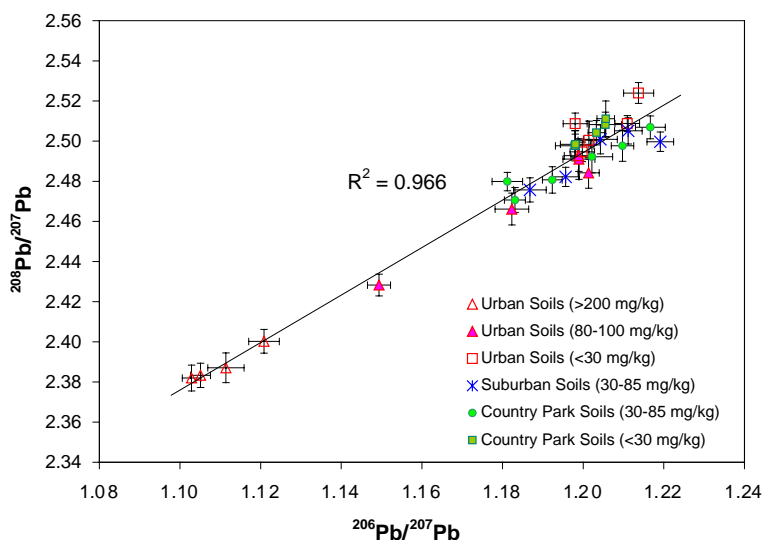

Fig. 10. $^{206}\text{Pb}/^{207}\text{Pb}$ and $^{208}\text{Pb}/^{207}\text{Pb}$ ratios of urban, suburban, and country park soils in Hong Kong Island.

country park soils with similar range of Pb concentrations. The result showed that some of the uncontaminated soils in the urban area reflected the Pb isotopic signatures of their parental materials. Therefore, the Pb isotopic ratios in soils were closely related to the Pb contamination and to its sources. The plot of the Pb concentrations against the $^{206}\text{Pb}/^{207}\text{Pb}$ and $^{208}\text{Pb}/^{207}\text{Pb}$ ratios is shown in Fig. 11. The Pb concentrations were found to form a polynomial line (degree=2) with the $^{208}\text{Pb}/^{207}\text{Pb}$ ($R^2=0.843$, $n=30$) and $^{206}\text{Pb}/^{207}\text{Pb}$ ($R^2=0.805$, $n=30$) ratios. The increase in the Pb concentrations of soils resulted in a lower rate of decrease in the Pb isotopic ratios ($^{208}\text{Pb}/^{207}\text{Pb}$ and $^{206}\text{Pb}/^{207}\text{Pb}$), reflecting the anthropogenic inputs of Pb from urban activities, particularly traffic emissions.

4. Conclusion

Multivariate statistical methods and geographical information system (GIS) were used to assess the degree of heavy metal contamination in the soils of the urban, suburban, and country park areas of

Hong Kong Island. The urban and suburban soils were highly enriched with metals such as Cu, Pb, and Zn, in comparison with the country park soils. The urban soils were found to be more contaminated than the suburban soils. The results of the principal component analysis (PCA) and cluster analysis (CA) showed distinctly different elemental associations and clustering patterns among metals in the urban, suburban, and country park soils. The soil pollution maps of Cd, Cr, Co, Cu, Ni, Pb, and Zn were generated using a GIS technique. The soil pollution index was formulated to indicate the degree of metal contamination (Cu, Pb, and Zn) in the soils. The three-dimensional map of the soil pollution index was overlaid with the thematic map of the Annual Average Daily Traffic (AADT). Many of the hot-spot areas were found in high traffic zones with an AADT figure of over 40,000 vehicles. The Pb isotopic composition analysis suggested that vehicular emissions were the major sources of Pb in the urban and suburban soils. The present study demonstrated the value of GIS and multivariate statistical methods in studying metal contamination in complex urban settings.

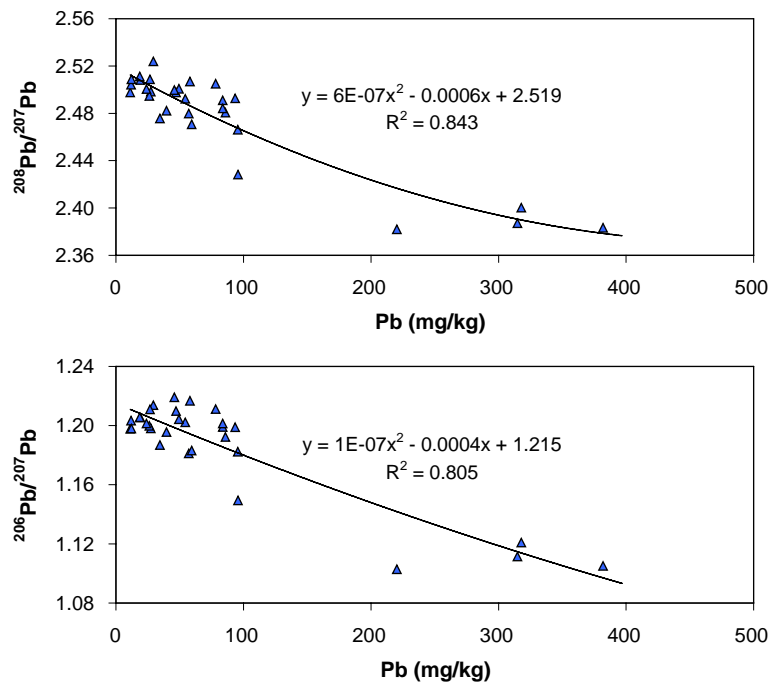

Fig. 11. $^{208}\text{Pb}/^{207}\text{Pb}$ and $^{206}\text{Pb}/^{207}\text{Pb}$ ratios vs. the Pb concentration diagrams of urban, suburban, and country park soils in Hong Kong Island.

Acknowledgements

The project was supported by a research grant from the Research Grants Council of the Hong Kong SAR Government (PolyU 5062/01E and 3-ZB40). We would like to thank C. C. Wang, Carman Ip, and Jun Li for their assistance in the soil sampling and the analysis.

References

- Alloway BJ. Heavy metals in soils. London: Blackie; 1990.
- Banat KM, Howari FM, Al-Hamad AA. Heavy metals in urban soils of central Jordan: should we worry about their environmental risks? *Environ Res* 2004;97:258–73.
- Bocca B, Alimonti A, Petrucci F, Violante N, Sancesario G, Forte G. Quantification of trace elements by sector field inductively coupled plasma spectrometry in urine, serum, blood and cerebrospinal fluid of patients with Parkinson's disease. *Spectrochim Acta* 2004;B59:559–66.
- Bollhöfer A, Rosman KJR. Isotopic source signatures for atmospheric lead: the Northern Hemisphere. *Geochim Cosmochim Acta* 2001;11:1727–40.
- Chen TB, Wong JWC, Zhou HY, Wong MH. Assessment of trace metal distribution and contamination in surface soils of Hong Kong. *Environ Pollut* 1997;96:61–8.
- Culbard EB, Thornton I, Watt J, Wheatley M, Moorcroft S, Thompson M. Metal contamination in British urban dusts and soils. *J Environ Qual* 1988;17:226–34.
- Davies DJA, Thornton I, Watt JM, Culbard EB, Harvey PG, Delves HT. Lead intake and blood lead in two-year-old UK urban children. *Sci Total Environ* 1990;90:13–29.
- Department of Soil Protection, Netherlands. The Netherlands Soil Contamination Guidelines, Netherlands Intervention Values for Soil Remediation; 1994. Reference #DBO/07494013.
- Duzgoren-Aydin NS, Li XD, Wong SC. Lead contamination and isotope signatures in the urban environment of Hong Kong. *Environ Int* 2004;30:209–17.
- Facchinelli A, Sacchi E, Mallen L. Multivariate statistical and GIS-based approach to identify heavy metal sources in soils. *Environ Pollut* 2001;114:313–24.
- Harrison RM, Laxen DPH, Wilson SJ. Chemical associations of lead, cadmium, copper, and zinc in street dusts and roadside soils. *Environ Sci Technol* 1981;15:1378–83.
- Hashisho Z, El-Fadel M. Impacts of traffic-induced lead emissions on air, soil and blood lead levels in Beirut. *Environ Monit Assess* 2004;93:185–202.
- Information Services Department, Hong Kong. Hong Kong Facts Sheets, Hong Kong SAR Government Publication; 2004.
- Kabata-Pendias A, Pendias H. Trace elements in soils and plants 2nd edition. Boca Raton, Florida: CRC Press; 1992.
- Kuang C, Neumann T, Norra S, Stuben D. Land use-related chemical composition of street sediments in Beijing. *Environ Sci Pollut Res* 2004;11:73–83.
- Lau WM, Wong MH. An ecological survey of lead contents in roadside dusts and soils in Hong Kong. *Environ Res* 1982;28:39–54.
- Li XD, Poon CS, Liu PS. Heavy metal contamination of urban soils and street dusts in Hong Kong. *Appl Geochem* 2001;16:1361–8.
- Li XD, Lee SL, Wong SC, Shi WZ, Thornton I. The study of metal contamination in urban soils of Hong Kong using a GIS-based approach. *Environ Pollut* 2004;129:113–24.
- Mielke HW, Gonzales CR, Smith MK, Mielke PW. The urban environment and children's health: soils as an integrator of lead, zinc, and cadmium in New Orleans, Louisiana, USA. *Environ Res* 1999;A81:117–29.
- Mielke HW, Gonzales CR, Smith MK, Mielke PW. Quantities and associations of lead, zinc, cadmium, manganese, chromium, nickel, vanadium, and copper in fresh Mississippi delta alluvium and New Orleans alluvial soils. *Sci Total Environ* 2000;246:249–59.
- Mireles A, Solís C, Andrade E, Lagunas-Solar M, Piña C, Floccchini RG. Heavy metal accumulation in plants and soil irrigated with wastewater from Mexico City. *Nucl Instrum Methods Phys Res B Beam Interact Mater Atoms* 2004;219–220:187–90.
- Norra S, Weber A, Kramer U, Stuben D. Mapping of trace metals in urban soils. *J Soil Sediment* 2001;1:77–97.
- Nriagu JO. A silent epidemic of environmental metal poisoning? *Environ Pollut* 1988;50:139–61.
- Raghunath R, Tripathi RM, Kumar AV, Sathe AP, Khandekar RN, Nambi KSV. Assessment of Pb, Cd, Cu, and Zn exposures of 6- to 10-year-old children in Mumbai. *Environ Res* 1999;80:215–21.
- Romic M, Romic D. Heavy metals distribution in agricultural topsoils in urban area. *Environ Geol* 2003;43:795–805.
- Schuhmacher M, Meneses M, Granero S, Lobet JM, Domingo JL. Trace element pollution of soils collected near a municipal solid waste incinerator: human health risk. *Bull Environ Contam Toxicol* 1997;59:861–7.
- Tao S. Kriging and mapping of copper, lead, and mercury contents in surface soil in Shenzhen area. *Water Air Soil Pollut* 1995;83:161–72.
- Thompson CM, Markesbery WR, Ehmann WD, Mao YX, Vance DE. Regional brain trace-element studies in Alzheimer's disease. *Neurotoxicity* 1988;9:1–7.
- Thornton I. Metal contamination of soils in urban areas. In: Bullock P, Gregory PJ, editors. *Soils in the urban environment*. Blackwell; 1991. p. 47–75.
- Transport Department, Hong Kong, 2002. The Annual Traffic Census. Hong Kong SAR Government Publication.
- Waisberg M, Joseph P, Hale B, Beyersmann D. Molecular and cellular mechanisms of cadmium carcinogenesis. *Toxicology* 2003;192:95–117.
- Wang T, Poon CN, Kwok YH, Li YS. Characterizing the temporal variability and emission patterns of pollution plumes in the Pearl River Delta of China. *Atmos Environ* 2003;37:3539–50.
- Wong MH, Tam FY. Lead contamination of soil and vegetables grown near motorway in Hong Kong. *J Environ Health* 1978;A13:13–22.

- Wong CSC, Li XD. Pb contamination and isotopic composition of urban soils in Hong Kong. *Sci Total Environ* 2004;319:185–95.
- Wong CSC, Li XD, Zhang G, Qi SH, Peng XZ. Atmospheric deposition of heavy metals in the Pearl River Delta, China. *Atmos Environ* 2003;37:767–76.
- Yáñez L, García-Nieto E, Rojas E, Carrizales L, Mejía J, Calderón J. DNA damage in blood cells from children exposed to arsenic and lead in a mining area. *Environ Res* 2003;93:231–40.
- Zhu BQ, Chen YW, Peng JH. Lead isotope geochemistry of the urban environment in the Pearl River Delta. *Appl Geochem* 2001;16:409–17.