

# Social Studies of Science

<http://sss.sagepub.com>

---

**The Uncertain but Crucial Relationship between a 'New Energy'  
Technology and Global Environmental Problems: The Complex Case of  
the 'Sunshine' Project**

Miwao Matsumoto

*Social Studies of Science* 2005; 35; 623

DOI: 10.1177/0306312705052107

The online version of this article can be found at:  
<http://sss.sagepub.com/cgi/content/abstract/35/4/623>

---

Published by:

 SAGE Publications

<http://www.sagepublications.com>

**Additional services and information for *Social Studies of Science* can be found at:**

**Email Alerts:** <http://sss.sagepub.com/cgi/alerts>

**Subscriptions:** <http://sss.sagepub.com/subscriptions>

**Reprints:** <http://www.sagepub.com/journalsReprints.nav>

**Permissions:** <http://www.sagepub.com/journalsPermissions.nav>

# S|S|S

**ABSTRACT** This paper describes, analyses and illuminates complex unnoticed aspects of the 'Sunshine' project in Japan. The 'Sunshine' project was launched by the Ministry of International Trade and Industry (MITI) as a large-scale and long-term project with the aim of developing 'new energy' technology. It continued from the 1970s through the early 1990s. Particular reference is made to the unexpectedly complex relationship between the ocean thermal energy conversion technology developed by the project and stratospheric ozone depletion. The paper shows that the unexpected and complex relationship between 'new energy' technology development and irreversible environmental change can be reduced to the problems of assessment and decision-making in situations of uncertainty. Based on this insight, a model for assessing large-scale, long-term technological development projects through a reflexive 'feedback-for-learning' channel is proposed. Finally, the paper introduces a sociological implication of the study: the principle of 'mild freezing', a perspective that builds upon and complements the precautionary principle.

**Keywords** global environmental problems, 'new energy' technology, precautionary principle, 'Sunshine' project, uncertainty

## The Uncertain but Crucial Relationship between a 'New Energy' Technology and Global Environmental Problems:

### The Complex Case of the 'Sunshine' Project

*Miwao Matsumoto*

This paper investigates the social process through which a 'new energy' technology – the 'Sunshine' project in Japan, under the aegis of which a new ocean energy technology was developed from 1974 to 1992 – generated the completely unintended consequence of potentially aggravating global environmental problems. The technology was originally designed to produce clean energy, while avoiding environmental damage. The paper explains the discrepancy between the intended purposes and actual consequences of the technology by describing, analysing and discussing unnoticed aspects of the 'Sunshine' project. Special attention is paid to the unexpectedly complex relationship of the development of ocean thermal energy conversion (OTEC) to irreversible global environmental change, such as stratospheric ozone depletion.<sup>1</sup> Sociological implications will be

*Social Studies of Science* 35/4(August 2005) 623–651  
© SSS and SAGE Publications (London, Thousand Oaks CA, New Delhi)  
ISSN 0306-3127 DOI: 10.1177/0306312705052107  
www.sagepublications.com



discussed, and particular principles will be suggested for allocating responsibility for problems arising under conditions of uncertainty at the science–technology–society interface.

### **How Did the ‘Sunshine’ Project Originate? The Social Background of the Development of a New Energy Technology in Japan**

The Middle East War that broke out on 6 October 1973 dramatically reduced the supply of crude oil, driving up the price and causing an oil crisis, which was keenly felt in Japan. The next year, the ‘Sunshine’ project was announced as the first national development of ‘new energy’ technology.<sup>2</sup> This long-term project, planned in anticipation of the projected supply and demand for energy in the year 2000, sought to develop a new, clean source of energy that would not give rise to environmental problems. The official gazette stated its aim as: ‘Development of a new technology to produce clean energy by the year 2000 through various medium-term research projects of several years each, and to satisfy a great percentage of the energy demand for several decades in the future.’<sup>3</sup>

‘Development of a new technology to produce clean energy’ is one of the main ways to cope with resource problems while considering the environment. There is a wide variety of ‘new energy’ technologies of this sort available at various stages of development: super-efficient gas turbines, liquid coal, sunlight, heat pumps, HDR (Hot Dry Rock) electricity production, fuel cells, wind turbines, biomass and nuclear fusion. They include technologies making use of both renewable and non-renewable energy sources. Some have already been put into effect or are deemed feasible in the near future, and others have either not been put into effect or are not deemed feasible. If we were to include all the ideas that have been proposed but soon dropped, the list would be much longer.

There is one characteristic common to all of the ‘new energy’ technologies: they are intended to supplement and/or replace energy technologies using fossil fuels, particularly oil. Taking into account the geopolitical situation of Japan, with its near total reliance on imported oil and its lack of gas or coal reserves, the development of ‘new energy’ technology is a crucial substitute for oil, the only other available major energy source being nuclear fission.

According to the Special Law for the Promotion of the Utilization of New Energy enacted in 1997, ‘new energy’ is defined as ‘power obtainable from the production and utilization of oil-substitute energy and electricity which could be particularly contributory to decreasing the degree of oil-dependence, and therefore requires aid continuously, but is still not in widespread use due to insufficient economy.’<sup>4</sup> This definition of ‘new energy’ itself originates from the Law for the Development and Promotion of Oil-substitute Energy (Law No. 71) of 30 May 1980. Thus in Japan ‘new energy’ has for a long time meant, almost exclusively, substitutes for oil,

and the first national project to develop such technology was the 'Sunshine' project.

The social shaping of the 'Sunshine' project from its inception was characterized by a conscious effort to create links between the governmental, industrial and academic sectors. The Ministry of International Trade and Industry (MITI), national test and research institutes, universities and private corporations spearheaded basic research for the project. MITI, and particularly its Agency of Industrial Technology (AIT), worked most closely with the test and research institutes that it governed. MITI had a client-trustee relationship with universities and private corporations. In applied and developmental research, MITI, the New Energy Development Organization (NEDO) and private corporations took the lead. The closest link was between MITI and NEDO, which was established in 1980 to satisfy the need for a single, unified research organization for development and application, a step which had been expected since the start of the 'Sunshine' project.<sup>5</sup> MITI controlled the expenditure of funds (investment, trust money, grants, supply money, subsidies) and supervised the organization's work. NEDO's relationship with the private corporations was one of trust. All agents concerned were expected to provide mutual feedback between basic and applied/developmental research.

The 'Sunshine' Project Promotion Headquarters established within the AIT controlled all the project teams. Project ideas were selected and evaluated by the New Energy Development Subcommittee of the Industrial Technology Council, an advisory organ for MITI. The budget increased about 16-fold during this period.<sup>6</sup> This increase resulted from the Special Account Law for Promoting Power Development and the Special Account Law for Coal, Oil, and Oil-Substitute Energies, which came into effect in May 1980. A special account has its own source of revenue independent of the general account, with a specific purpose given priority by the government so that there is usually a higher degree of freedom in the execution of the budget than under the general account. From the budgetary viewpoint, the 'Sunshine' project was thus an independent, long-term, large-scale project distinct from MITI's other – more ordinary – large-scale projects.<sup>7</sup>

The project covered five main areas: (1) solar energy; (2) geothermal energy; (3) coal energy; (4) hydrogen energy; and (5) wind and ocean energy. The project was planned to advance through phases, starting with basic research, through conceptual design, development of component technology, and construction and operation of pilot, practical, and finally, commercial plants.

One could evaluate the project by taking each phase of the five areas and examining its eventual contribution to the originally conceived purpose – for example, the construction and full-scale operation of OTEC commercial plants to solve resource problems. However, this paper argues that the 'Sunshine' project had an aspect that should be evaluated in the light of completely different standards, independent of any evaluation of individual contributions to the purpose of the project. The reason is that an

independent, large-scale, long-term technological development project such as the 'Sunshine' project requires an analysis of its intricate connection with global environmental assessments. That is to say, such projects tend to produce an unanticipated degree of complexity that necessitates global environmental assessment. An account of how ocean energy development in the 'Sunshine' project started will substantiate this approach.

### The Ocean Energy Development Project and Global Environmental Assessment: The Complex Case of Ocean Thermal Energy Conversion

The ocean energy development project consisted of the following five sub-projects: (1) wave-activated power generation; (2) OTEC; (3) tidal power generation; (4) ocean current power generation; (5) ocean density power generation. The development of OTEC merits particular attention to the relation between technological development and global environmental problems, because a detailed analysis of the project enables us to pinpoint where the global environmental assessment was significant in relation to unexpected technological developments. The other reason for this particular focus is that in the mid 1970s OTEC was supposed to be greatly superior to the other four ocean energy development sub-projects in terms of the availability of resources, output stability and cost. Consequently, OTEC appeared the most promising and attracted the most attention at the time.<sup>8</sup>

Haruo Uehara, who was a professor of Saga University and one of the best-known proponents of OTEC, published a paper in 1977 titled 'Current Status and Technological Aspects of OTEC' in *Machinery Studies (Kikai no Kenkyu)*. At the outset of the paper, he states:

For the human being, energy is one of the most important concerns. At present, Japan relies on oil imports for most of its energy needs. Considering the geographical location of Japan, we should make the utmost effort to exploit the energy resources of the sea. The thermal energy of the ocean can produce electric power. (Uehara, 1977: 1)

According to Uehara, 'The power available within the 200 sea-mile area around Japan is about ten billion kW if produced at current technological efficiency. This is about ten times the energy (one billion kW) that Japan will require in the year 2000' (Uehara, 1977: 1–2). It is clear that he considered OTEC a trump card that would solve resource problems. The next year Hiroshi Kamogawa, chairman of the Committee on OTEC of the 'Sunshine' project at the AIT, published a paper titled 'OTEC for Solving Resource Problems' in the *Monthly Report of the Federation of Economic Organizations (Keidanren Geppo)*. He stated:

OTEC has the potential to satisfy energy demand, the demand for sea-food resources, and contribute to increased output of industrial raw materials including uranium. . . . We hope that the Japanese government will pay most attention to OTEC at the national level and promote its development immediately. (Kamogawa, 1978: 82)

In the same year, an even brighter and at the same time more concrete picture of the prospects for OTEC was painted by a report of the Marine Science and Technology Centre of the Science and Technology Agency (STA). The report stated:

We can expect a maximum output of 100 MWe – 400 MWe per single OTEC plant. It is estimated that, with proper design and a viable commercial plant, OTEC will enable Japan, the USA, and European countries to produce electricity in the 1990s at broadly the same moderate cost as today.<sup>9</sup>

OTEC is based on the very simple principle of converting the thermal difference between the warm surface water and the cold subsurface water into electrical energy. A French physicist, Jacques A. d'Arsonval hit upon the idea at the end of the 19th century.<sup>10</sup> There are two ways to apply the idea practically. One is a closed-cycle (CC) system where the working fluid circulates, the other is an open-cycle (OC) one in which it does not. CC was proposed by d'Arsonval himself, and OC was invented by a French industrial chemist, Georges Claude, a former student of Arsonval and well known for his successful production of synthetic NH<sub>3</sub>. The earliest trial of OTEC was made using an OC system constructed by Claude in Cuba in 1928, which proved a disappointing failure (Claude, 1930).<sup>11</sup> CC became the focus of full-scale OTEC research after J.H. Anderson and J.H. Anderson Jr of the USA obtained a patent for the CC system in 1967.<sup>12</sup>

Thus far, the pioneering research and development (R & D) of OTEC was carried out mainly by France and the USA. Based on these pioneering efforts, there were a number of attempts in the 1980s to carry out OTEC development in various other parts of the world (the UK, the Netherlands and Sweden, among other nations). This was shortly before Japan entered the field.<sup>13</sup>

In Japan, a feasibility study of the CC system was undertaken right after the start of the 'Sunshine' project in 1974. The OTEC system (CC hereafter except where otherwise indicated) consisted of three sub-systems: (1) a system for circulating warm water; (2) a system for circulating cold water; and (3) a system for circulating a working fluid (see Figure 1). Japan had constructed three pilot plants by 1988.

Under the accelerating development plan drafted by the 'Sunshine' project team, an OTEC pilot plant with an output capacity of about 1000 kW was to be constructed by the fiscal year 1991. Construction of the commercial plant was scheduled for the fiscal year 1991 or after.<sup>14</sup> By the fiscal year 2003, not only was no commercial plant in operation, but no further working OTEC plant has been constructed since the initial three pilot plants.<sup>15</sup> However, in this case, what is more important than an assessment of how far a target was reached is an assessment of the way the initial technology selection was made, because the selection of OTEC technology had an important relationship to global environmental problems.

FIGURE 1  
The concept of ocean thermal energy conversion (OTEC).

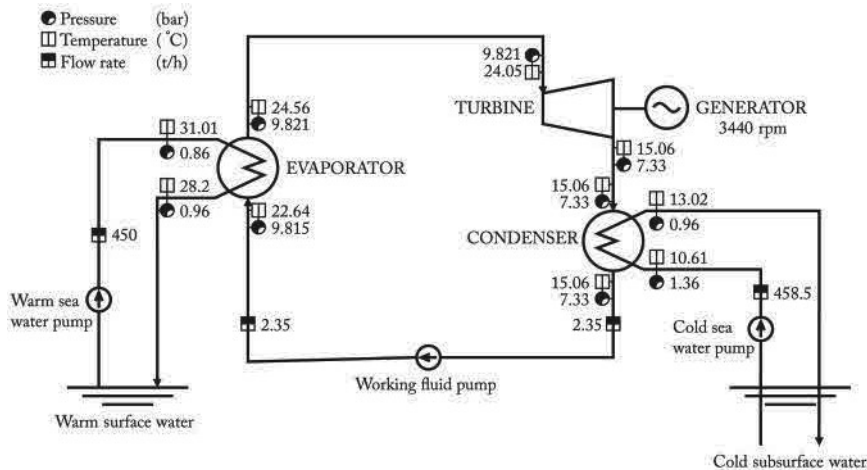

Source: Showa 61 Nendo Sunshine Keikaku Kenkyu Kaihatsu no Gaikyo (Sogo Kenkyu) (The Outline of Research and Development of the 'Sunshine' Project for Fiscal 1986) (Tokyo: Nihon Sangyo Gijutsu Shinko Kyokai, April 1987: 45).

The critical problem in making OTEC sustainable and/or feasible is how to use the small decrease in heat between warm and cold sea water. The average water temperature is about 28°C at the surface and about 7°C in subsurface sea water. The temperature difference is therefore only about 20°C, as against several hundred degrees in the usual thermal power generation methods. To generate power from this small heat drop, the efficiency of the heat cycle must be enhanced. Since the surface water temperature is only about 28°C, water, used in large quantities as the working fluid in standard thermal power generation, is of no use in OTEC. This critical problem was solved in the 'Sunshine' project by using a working fluid containing chlorofluorocarbon (CFC) compounds.

A compound working fluid for OTEC composed of CFC-12 and CFC-21 was developed at the basic research stage of the 'Sunshine' project. In the working fluid, CFC accounted for about 99% of the fluid, with CFC-12 accounting for about 85%.<sup>16</sup> It is well known that CFC-12 is considered to be the chemical most likely to be responsible for the depletion of the stratospheric ozone layer. On the other hand, the purpose of the 'Sunshine' project was to develop a clean energy source that would not damage the environment. These two facts invite the following question: why was this ozone-depleting substance adopted as the principal component of the working fluid for OTEC in the 'Sunshine' project? According to the contemporary agents concerned, there were three reasons: (1) high thermal conductivity; (2) low boiling point (29.8°C for CFC-12); (3) easy handling and availability (because of high chemical stability due to the C-F combination).<sup>17</sup>

The first proposal to employ CFCs as the working fluid for OTEC dates back to the start of the 'Sunshine' project in 1974. In that year a conceptual design for a 1.5 MW OTEC plant was produced as a feasibility study, and the design proposal stated:

Two plans are proposed, and details are given of the performance and the specified designs of these plans. One plan employs a design combining the steam cycle of existing power plants with a working fluid having a low boiling point, such as a CFC, circulated by means of pumped water. The other plan performs heat exchange by connecting the two cycles directly.<sup>18</sup>

From then on, CFCs were an important candidate for the working fluid for OTEC, along with others such as  $\text{NH}_3$ ,  $\text{CH}_3(\text{CH}_2)_2\text{CH}_3$  and  $\text{C}_3\text{H}_8$ . In fact, the first successfully working pilot plant, constructed in the Republic of Nauru by Tokyo Electric Power Co. with funds from the Official Development Assistance of the Japanese Government and the AIT of MITI, used CFC in its working fluid (see Figure 2).

For this working pilot plant CFC-22 was singled out to make use of the heat drop created between warm water at  $29.8^\circ\text{C}$  and cold water at  $7.8^\circ\text{C}$ . For that purpose, a new CFC turbine was developed, which was

**FIGURE 2**  
The concept of the first working ocean thermal energy conversion (OTEC) pilot plant

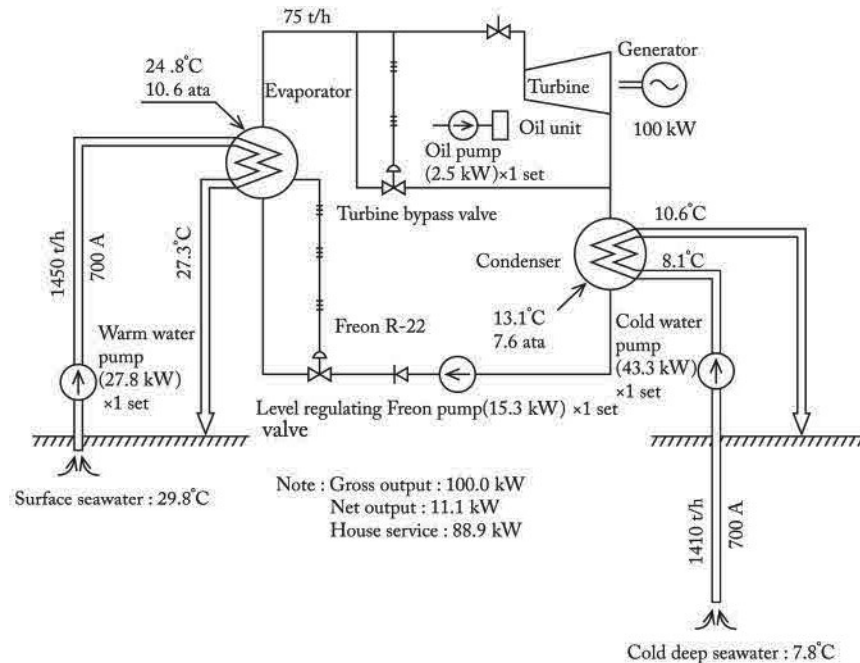

Source: ECOR (Engineering Committee on Ocean Resources), Japan Marine Science and Technology Association (Japan National Committee for ECOR), Ocean Energy Systems: Report of ECOR International Working Group (February 1989: 83).

described at the time as being ‘the vanguard of energy-saving’, and test experiments starting in 1981 provided important data on the working of the turbine.<sup>19</sup> A continuous run test was carried out for ten days using the working pilot plant, during which all kinds of experiments relating to generating capacity were undertaken. The report of the experiments evaluated their results as follows:

We find that OTEC is a stable means of electricity supply. Various test experiments of the dynamic characteristics of OTEC in terms of the rotation control, start, stop, and load fluctuation, and so forth have been undertaken, and all of them demonstrate that OTEC has sufficient stability for a generating system.<sup>20</sup>

Thus, on the one hand, CFCs were considered to be the optimal technological choice for enhancing the efficiency of the heat cycle to solve the problem of the small heat drop in OTEC. On the other hand, they were a suspected ozone-depleting substance. Admittedly, in the case of the CC system where the working fluid circulates only within the system, it might seem unlikely that the fluid could escape from the system under ordinary running conditions (in a refrigerator, a very similar system, escapes during ordinary operation are very unusual). In the case of OTEC, however, the problem lay in the fact that a large number of plants were to be dispersed throughout a wide area of open sea. According to an estimate made by Hiroshi Kamogawa, a plant with an output of 100,000 kW would require at least sea area of 20 km<sup>2</sup>, assuming constant efficiency in extracting heat from the sea (Kamogawa, 1978).

In order to get the maximum heat from warm, surface sea water, it would have been necessary for Japan to locate OTEC plants in southern sea areas as close as possible to the Tropic of Cancer. Entirely coincidentally, on 1 July 1977, Japan set a 200 nautical mile economic limit and extended the range of its territorial waters from 3 to 12 nautical miles from the coast. Accordingly, the initial development plan mentioned earlier drafted by the ‘Sunshine’ project team meant that one OTEC plant should occupy every 20 km<sup>2</sup> area throughout the large sea area from 3 to perhaps 200 nautical miles from the coast of the southern half of Japan. In fact, a special map showing the potential output of total OTEC plants per year was produced on a latitude 1° × longitude 1° basis with particular emphasis on ‘more advantageous’ southern sea areas, according to which potential power output within 200 nautical miles was estimated at 1.06 × 10<sup>2</sup> GW per year.<sup>21</sup>

However, this is the very area where many seasonal typhoons pass, caused by the active evaporation of sea water. The area is also a main artery of sea transportation where many ships come and go. In fact, the area coincided with a designated sea-patrol area in which the Maritime Safety Agency is required to deploy one or more patrol boats constantly because of ‘frequent shipwrecks due to the traffic density of sea transportation and fishery vessels and sea and weather conditions.’<sup>22</sup> Furthermore, preventing the plants from drifting by continuously correcting for complex influences

from tidal currents ('dynamic positioning') posed another serious problem to be resolved.

If we take these conditions into account, the possibility is far from negligible that CFCs would escape on a large scale from plants damaged by natural disasters (typhoons, and so on) or accidents (collision with ships due to the weather and sea conditions, and to drifting from their stable stations). By the same token, a researcher of the Marine Energy Section of the Electrotechnical Laboratory of the AIT of MITI himself realized this, recommending in 1981:

The ocean is a place for biological resources and transportation, and so forth, as well as for energy development. Since the ocean is equally important for such a variety of different purposes, it should be kept in mind that energy plants to be placed in the ocean cannot be feasible until coexistence between these different purposes is secured. [Unfortunately this realization was not reflected in Japan's national policies of the day as mentioned later.] (Kajikawa et al., 1981: 423, Interpolation with brackets by the author)

In fact, contemporary statistics on shipwrecks tell us that the number of ships calling for rescue due to typhoons and accidents within 12 to 200 nautical miles from the coast was quite substantial (10% and more of the total number of shipwrecks in all sea areas around Japan).<sup>23</sup>

In short, the working fluid selected was optimal from a thermal energy conversion standpoint for technology within an OTEC plant, but it could become far from optimal just outside such a plant. Once again, then, why was such a technological choice made? The next section gives an answer to this question by going into the subtler background of the complex relation between OTEC and global environmental problems.

### **Subtler Aspects of the Social Background of the Complex Relationship Between Ocean Thermal Energy Conversion and the Global Environment**

One might imagine that the above technological choice was made only at the stage of basic research, with no intention to use CFCs as an actual working fluid. Table 1 proves that this was not so.

Table 1 lists the patents using CFCs as a working fluid for OTEC. All these patents pertained to the OTEC heat cycle and power generation system. As the table shows, seven patents using CFCs were applied for and published: they are numbered consecutively in order of the date of application. It should be noted that six of the seven patents were applied for and published by Asahi Glass Manufacturing Co., Ltd, the leader in terms of production capacity among the few CFC manufacturers in Japan. (The production capability of the company rose from 40,000 tons in 1980 to 91,200 tons in 1990.)<sup>24</sup> As a CFC manufacturer, Asahi Glass was rather a latecomer. During the period of high economic growth in the 1960s, the company decided to enter this field, for the following reasons:



More and more uses are being found for carbon fluoride as a coolant, spraying agent, and polyurethane foaming agent. In addition, high-purity natural gas is available at low cost from our mining area in Chiba. To make effective use of this natural gas supply and electrolytic chlorine obtained from caustic soda conversion, we should manufacture CFCs, then manufacture fluorine derivatives.<sup>25</sup>

Following this strategy, Asahi Glass built a CFC plant with a monthly production capacity of 500 tons within its Chiba factory and the plant started manufacturing CFCs in April 1964 (the plant started full production in the fiscal year 1967).<sup>26</sup>

The one remaining patent was applied for and published by Sanyo Electric Co., Ltd. The company was not a CFC manufacturer, but was manufacturing refrigerators, for which CFCs had been used as a coolant since the period of high economic growth of Japan in the 1960s. Particularly after the mid 1970s when the regulation of gas under high pressure became strict, the conversion from NH<sub>3</sub> to CFCs both at home and for industrial use was promoted by various policy measures, with the result that by the time the ozone depletion problem came to be taken seriously, CFCs had almost wiped out NH<sub>3</sub> in the coolant market in Japan.<sup>27</sup>

**TABLE 1**  
Patents related to ocean thermal energy conversion (OTEC)

Date of application	Laid-open number	Applicant	Title of patent	CFC used
1984.5.22	60-245686	AG	Compound Working fluid	R-11, R-12, R-22 R-114, R-115
1984.6.1	60-255884	AG	Compound Working fluid	R-22, R-133
1984.6.1	60-255885	AG	Compound Working fluid for Rankin cycle	R-12, R-124 R-115
1984.6.12	61-285	Sa E Tokyo Sa E	Compound Working fluid for Heat cycle	R-21, R-22
1984.7.24	61-31488	AG	Compound Working fluid	R-11, R-134
1984.7.31	60-37855	AG	Compound Working fluid	R-12, R-123b
1984.7.31	61-37856	AG	Compound Working fluid	R-22, R-123

Notes: The first figure in the Laid-open number indicates the year of the Japanese regional calendar in which the patent was made public: 60 is 1985, 61 is 1986. The first patent in the table uses one of the CFC put in the column or a combination: AG, Asahi Glass Manufacturing Co., Ltd; Sa E, Sanyo Electrical Engineering Co., Ltd; Tokyo Sa E, Tokyo Sanyo Electrical Engineering Co., Ltd.

Source: Produced from Showa 61 Nendo Sunshine Keikaku Itaku Chosa Kenkyu Seika Hokokusho: Tokkyo Joho Chosa Kenkyu, Kaiyo Ondosa Hatsuden (Report of Results of the Research by the 'Sunshine' Project for 1986-87: OTEC Patents), March 1987.

Thus it was a CFC manufacturer and a manufacturer using CFCs in its endproducts that selected CFC as the working fluid for OTEC. This means that intermediate products familiar to CFC manufacturers or to manufacturers using CFCs became the working fluid during the process of selection of technology for OTEC in the 'Sunshine' project, a project which began with the environmentally conscious aim of developing a clean source of energy. To be sure, we can generally observe a similar phenomenon in the process of technological 'spin-off' from one field to another. But an intrinsic problem arises when we look at the timing of this technological selection. As the patent application dates in Table 1 show, all the patents were applied for during the period from May to July 1984. It is worth discussing the social implications of this fact, because the first observation of an ozone hole was reported at almost the same time.

Shigeru Chubachi, a scientist in the Meteorological Agency, reported these stratospheric ozone densities, observed between February 1982 and January 1983, when he was working at the Showa station in Antarctica. What he expected to observe was the seasonal fluctuation of the stratospheric ozone density in Antarctica (Chubachi, 1984a). However, the result he obtained was the first evidence of the existence of an ozone hole. The paper was submitted to the English journal of the National Polar Research Institute in March 1984 and published in December of the same year.

On the theoretical side, M.J. Molina and F.S. Rowland predicted the depletion of the ozone layer in their paper published in 1974. They argued that CFC released into the air would reach the stratosphere without being decomposed in the troposphere. In the stratosphere, the sunlight would cause a free radical reaction and decompose the ozone quickly into O<sub>2</sub> and ClO. They made a provisional estimate of the results based on the total amount of CFCs produced up to that time and the rate of increase of their production, and concluded the paper with the following remark:

It seems quite clear that the atmosphere has only a finite capacity for absorbing Cl atoms produced in the stratosphere, and important consequences may result. . . . A lengthy period (of the order of calculated atmospheric lifetimes) may thus be required for natural moderation, even if the amount of Cl introduced into the stratosphere is reduced in the future. (Molina & Rowland, 1974: 812)

The prediction by Molina and Rowland triggered a sensation, particularly in the USA, but even after its publication, for a long time no computer simulation was able to predict the existence of an ozone hole. In this situation, Chubachi's paper was the first observational study that supported the theory of Molina and Rowland. As mentioned earlier, all the patents using CFCs as a working fluid for OTEC were applied for during May to July 1984. Chubachi's paper was published in December the same year.

This sequence of events strongly suggests that the agents who recommended using CFC as a working fluid for OTEC in the 'Sunshine' project completely lacked any perspective for connecting a 'new energy' technology for solving resource problems with stratospheric ozone depletion.<sup>28</sup>

Under Japanese law a patent must be published 18 months after application, and the patent applications were therefore all laid open in 1985 and 1986. What is significant here is that the publication of Chubachi's observation predated the public announcement of all these patents. Admittedly, the patents thus applied for were not actually accompanied by a request for immediate examination, so that the patent rights did not take immediate effect. Even so, it might seem extremely odd that patents using CFCs were published after stratospheric ozone depletion had been observed.

There is nothing especially odd about the patterns of behaviour in the scientific community at the time, however, since Chubachi's observation was ignored for a long time even after its publication. Three months before publishing his observational data, Chubachi presented them in detail at the International Ozone Symposium held in Greece (Chubachi, 1984b). However, his was the only presentation on the ozone layer above Antarctica, and no other participant showed any interest in the topic. According to him, all he was able to do was to hand out two-dozen preprints. The comments he got within the Meteorological Agency before his presentation at the symposium mostly reflected general scepticism about the observation, and he was advised to recheck the data.<sup>29</sup> It was not until 1987, when Nimbus 7, a US meteorological satellite, independently observed extremely low stratospheric ozone density above Antarctica, that Chubachi became known as one of the discoverers of the ozone hole. Thus it took nearly three years for the significance of his observation to be recognized, during which time (1985 and 1986) all the patents using CFCs for OTEC were published.<sup>30</sup>

This sequence of events indicates that the 'common sense' expectations of the scientific community delayed the acceptance of the ozone hole, and the global environmental problems it indicated. Although Chubachi's data were published in English, the absence of any corroboration may also have hindered acceptance of his evidence. Corroboration appeared just five months later, on 15 May 1985, when J.C. Farman and other members of the UK Antarctic observation team reported similar results in a paper published in *Nature* (Farman et al., 1985).<sup>31</sup>

This paper later became known in Europe and the USA as the first report of an actual ozone hole.<sup>32</sup> The paper not only reported the discovery of an ozone hole, but also rejected the theories that attributed that hole to natural phenomena (atmospheric motion), and suggested the possibility of chemical reactions resulting from artificial influences (release of CFCs).<sup>33</sup> These observational data thus further supported the forecast made by Molina and Rowland in 1974. That is to say, although Farman's team had not heard of Chubachi's paper, they effectively corroborated his data, which were eventually supported by the independent observation by Nimbus 7, thus causing the global environmental problem to be recognized as a social problem.<sup>34</sup>

In contrast to these developments in Europe and the USA, there was a curious situation in contemporary Japan with regard to the ozone layer and

environmental protection. The Environment Agency added an item 'CFC gas problem' to its White Paper on the Environment in 1981 and kept calling public attention to this problem every year until 1989. The item thus appeared for the first time three years before the 1984 application for patents using CFCs as a working fluid for OTEC, and five years before their publication. What then did the agency actually realize about the problem when the White Paper on the Environment first called attention to it? The 1981 White Paper states:

1. CFC gases, such as CFCs 11 and 12, used in aerosol and coolant products are chemically very stable. If the gases are released into the environment, they will reach the ozone layer without being decomposed and destroy the layer. As a result, the amount of ultraviolet rays reaching the earth's surface will increase, causing skin cancers and climate changes. If the ozone layer is depleted, serious problems on a global scale will occur. Early preventive measures are required to prevent these effects.

2. Outside Japan, the US and several other countries have legal restrictions on the release of CFC gases. The European Community decided to ban the release of CFCs into the atmosphere in March 1980.

3. This problem requires a full scientific analysis. In Japan, the Environment Agency and the Meteorological Agency have been conducting a continuous programme of scientific research to investigate the problem and will encourage further research in cooperation with the ministries and agencies concerned.<sup>35</sup>

By reference to the forecast made by M.J. Molina and F.S. Rowland, the White Paper first stated that it was worth taking preventive action to avoid serious problems. It then listed the positive actions taken by other countries. In its conclusion, it explained the necessity of taking action beyond the boundaries of individual ministries and agencies. Given the prior recognition of the problem and even of recommendations of appropriate guidelines for tackling it, why then were the CFC-based patents applied for and published? One possible explanation might be that the 'Sunshine' project produced the patents under the aegis of MITI, whose programmes were completely outside the authority of the Environment Agency.

However, since the White Paper stressed the 'cooperation with ministries and agencies concerned', the sectarianism of governmental agencies does not provide an excuse. In fact, the CFCs Problem Liaison Council was organized in September 1980 as a joint undertaking of the Environment Agency, MITI, the Ministry of Foreign Affairs, the Ministry of Welfare and the Meteorological Agency. Moreover, the Chief of the Chemical Products Division of the Basic Industries Bureau of MITI stated in 1988:

In view of the importance of the CFC problem for ozone layer protection, MITI has been tackling the problem since it was first realized. By administrative guidance, the ministry has frozen the production of CFCs 11 and 12 since May 1980 and is attempting to reduce the use of CFCs 11 and 12 in aerosol products. (Komiya, 1988)

Furthermore, in the 'Sunshine' project, the 'new energy' technology development policy of MITI was drafted from the outset in a way that was closely coupled with the environmental protection policy. An official gazette stated as early as 1973: 'Environmental protection is now a matter of top national priority. It must be a foremost principle that energy should be supplied and consumed within the bounds of environmental capacity.'<sup>36</sup> Thus, despite the relevant governmental authorities' realization of the possibility of stratospheric ozone depletion by CFCs, the CFC-based patents were applied for and published in connection with a 'new energy' technology development project seeking clean energy.

These facts might suggest that during the 1980s, when the 'new energy' technology development project started, basic research was undertaken, and the patents using CFCs as a working fluid were applied for and published, there were at least two possible channels in Japan through which 'feedback-for-learning' might have occurred. First, the Environment Agency and MITI planned political guidelines and issued administrative instructions based on their realization that CFCs could be ozone-depleting. At this moment, Japan might have been able to institute a 'feedback-for-learning' channel that would have reassessed the already initiated 'new energy' technology development project in light of the information about CFCs, and would have amended the individual programmes. Second, when S. Chubachi reported the ozone hole at the Meteorological Research Institute of the Meteorological Agency, CFCs could have come under increased suspicion as ozone-depleting substances. At this moment, Japan might have been able to institute another 'feedback-for-learning' channel that would have reassessed the development project based on this observation and would have amended the individual programmes.

In reality, however, neither channel existed at the time. Japan's administrative organizations apparently did not include reflexive assessment and reassessment channels. They were not able to take appropriate action to pursue the development of new energy technologies while simultaneously seeking to relieve global environmental problems. This policy failure occurred despite the fact that information had been available on the relationship between technological development and environmental policy since the very beginning of the 'Sunshine' project.

Ironically, Hiroshi Kamogawa, the aforementioned chairman of the Committee on OTEC in the 'Sunshine' project at the AIT, pointed out a possible relationship between OTEC and environmental change in the same paper that urged immediate promotion of OTEC development as a trump card for solving resource problems. According to him, there might be two ways that OTEC could affect the environment: first, cold and warm waste-water from OTEC could affect marine ecological systems; second, the complex behaviour of cold waste-water around the surface sea water could change the evaporation velocity of the sea water, which could lead to local changes in the state of the ocean around OTEC plants and changes in the climate in the troposphere (Kamogawa, 1978).<sup>35</sup> As mentioned earlier,

these possibilities were not reflected in Japan's OTEC development policy at the time. Furthermore, more global possibilities were not included in Kamogawa's consideration of ecological consequences: the possibility of ecological effects on large areas of the ocean and on the stratosphere.

What, then, enabled the project to run continuously without having recourse to the 'feedback-for-learning' channels mentioned earlier? This question leads us to an important clue for clarifying and elaborating upon the social context and implications of the 'Sunshine' project.

### **Decision-Making in the Absence of Complete Information: Reversible Technological Development and Irreversible Environmental Change**

There are two major social contexts associated with the time periods in which the 'Sunshine' project, and particularly OTEC development, took place. One is relevant to the whole process of OTEC development, from its inception to its stagnation and fade-out, a process that extended from 1974 to the early 1990s. The other is relevant to the later revival of OTEC development, starting at around the time that the 'Sunshine' project ended in 1992.

During the first period, from 1974 to the early 1990s, OTEC development was close in time to the Middle East War of October 1973, which triggered a global oil crisis. The fact that the 'Sunshine' project was initiated in July 1974 might lead us to infer that 'new energy' technology development in Japan got started as a result of the oil crisis, but this was not the case.

On 18 May 1973, a meeting was held of officials in charge of the future development plan for the AIT in MITI, and a plan for creating a 'new energy' development section within the AIT was adopted and authorized. This plan was independent of the oil crisis, which had not yet occurred. The newly established section became the headquarters of the 'Sunshine' project when it started about five months later. In an independent development, on 18 August 1973, still about two months before the oil crisis, MITI submitted the following enquiry to the Special Commission on Industrial Technology: 'What kind of new industrial technology should be developed to enhance the well-being of the nation and to promote international collaboration in accordance with socio-economic needs, and how? In particular, how should the development of energy technologies be designed to avoid an energy crisis in the future and contribute to environmental protection?' (This is the title of the enquiry No. 1 from MITI to the Special Commission on Industrial Technology.) In the contemporary industrial sector as well, there appeared to be awareness that the strongly oil-dependent energy policy had come to a turning point.<sup>37</sup> In fact, in January 1973, about nine months before the oil crisis, the Federation of Economic Organizations made an official call to break away from an over-dependence on oil.<sup>38</sup> In other words, the policy measures taken for 'new energy' technology development emerged from the endogenous initiative of both

the governmental and industrial sectors, rather than from external events such as the oil crisis.

The early creation of institutional settings in which such endogenous initiatives could be canalized and materialized was another social mechanism associated with the start-up of OTEC development. A strong example of these initiatives was the drastic reorganization of the Electrical Testing Laboratory of the AIT into the Electrotechnical Laboratory in 1970. The Electrical Testing Laboratory was one of the oldest national research institutes in Japan, originating in the Telegraph Laboratory set up in 1873, and the purpose of its reorganization in 1970 was to expand research activities far beyond the practical business of testing and developing standards – activities in which the laboratory had long specialized.

The advent of pioneering attempts since the 1960s to produce electricity by various new technologies, such as nuclear fission, Magneto-Hydro-Dynamics (MHD) and thermoelectromotive force, made it necessary for the laboratory to upgrade its research function to keep abreast of new technologies for the production of electricity. By 1970, the major practical tasks of testing and standards had been transferred to external organizations (for example, the Japan Electrical Appliances Testing Institute, the Japan Electrical Instruments Testing Institute). Against this background, as part of the reorganization in 1970, the Electricity Supply Division and the Instruments Division of the Electrical Testing Laboratory were integrated into the Energy Section, where OTEC development was carried out after the start of the ‘Sunshine’ project.<sup>39</sup> Thus, independent of the oil crisis, the governmental and industrial sectors aimed to break away from a long-standing oil-dependent energy policy (a ‘pull’ factor) and to initiate a concomitant reorganization of research settings that created room for ‘new energy’ development (a ‘push’ factor). These were the actual social mechanisms at work in the process of starting up OTEC development in the ‘Sunshine’ project.

An interaction between high technology and technologies for commercialization ensued, and it is here that we can find the basic reason for the later stagnation and fade-out of OTEC development. In the case of the CC-type of OTEC that was developed in the ‘Sunshine’ project, the key high-technology element was a system enabling the efficiency of the generating system to be enhanced, and the key technology for commercialization was a system that would enable large-scale and efficient transmission of electricity from the OTEC plant in the ocean to the land. R & D of the high-technology element began in 1974, when, as mentioned earlier, the conceptual design of a 1.5 MW OTEC plant was drawn up in a feasibility study for the ‘Sunshine’ project. The R & D of the technology for commercialization began in 1977, when a conceptual design for a transmission system was made by a project team to estimate the cost of transmitting AC 80 MW over a distance of 20 km.<sup>40</sup> On the high technology side, the development of a new working fluid to enhance heat-cycle efficiency and new chemicals to prevent biofouling of the condenser

followed; on the technology for commercialization side, there was investigation of the possibility of using microwave transmission and a new system to transform energy into chemicals such as  $H_2$ ,  $NH_3$  and  $CH_4$ .

Despite all these efforts, however, there was no breakthrough with either technology. And the OTEC development unit was downsized after the 'Sunshine' project came to an end in 1992. The Electrotechnical Laboratory, which provided the locus of OTEC development in the start-up stage of the project, finally announced its decision to withdraw from OTEC development, publishing its last short report on OTEC in 1997 (Takazawa et al. 1997).<sup>41</sup> The main reason for the decision was difficulty in finding sites where OTEC could achieve economy comparable with that achieved by existing generating systems. The OTEC Research Association, one of the short-lived (1988–94) research groups surrounding OTEC, described the situation as follows:

Based on comprehensive R & D we have carried out up to now in relation to technologies for the generating system, cold water intake, multi-purpose utilization, and so on, and a survey for site selection around the Southern Pacific, we find it difficult to implement a construction plan for OTEC plants that would enable sufficient economy to be achieved even around the equator.<sup>42</sup>

Quite separately from the possibility of causing global effects on large areas of the ocean and on the stratospheric ozone layer, OTEC development stagnated and faded out because of the incomplete transformation of high technologies into technologies for commercialization. In other words, it failed to achieve sufficient economy to recover the huge initial cost of construction. Notwithstanding the fact that the move to 'new energy' development in Japan originated from the initiative of the governmental and industrial sectors, and OTEC development once symbolized endogenous initiative for such development, now there is no OTEC development as prescribed by the New Energy Promotion Law enacted in 1997. In fact, ocean energy development as a whole is absent from the target of the 'new energy' technology development strategy, projected for 2030; instead, the target is focused on sunlight, solar thermal power, wind turbines, biomass, heat pumps, natural gas co-generation, fuel cells and electric vehicles. And the new 'Sunshine' project started in 1993 aims for the development of solar power, geothermal power and wind power, with no OTEC or other ocean energy.<sup>43</sup>

However, these developments do not mean that OTEC entirely disappeared. In fact, there was a noticeable resurgence of OTEC, starting around the end of the 'Sunshine' project in 1992. The most direct indicator of the trend was the eighteen OTEC-related patents obtained since 1990 (Table 2).

Two important points are evident from this list of patents. First, various component technologies of the CC-type of OTEC developed in the 'Sunshine' project can serve a vast range of objectives in fields unrelated to the production of electricity, such as the purification of water,



heat exchange, fresh water production, transportation of fluid and the utilization of deep subsurface water. This phenomenon is a 'spin-off' of elementary technologies from one field to another. The other important point is the shift from CC-type OTEC to OC-type as seen in patents 1 and 15 in Table 2. In contrast to the CC-type of OTEC developed in the 'Sunshine' project, which could potentially affect large areas of the ocean and stratosphere, OC is a technology that can avoid that damage. Both CC and OC share the difficulty of achieving sufficient economy for commercial production of electricity, a problem that is more serious for OC because of its more severe technical difficulties (creating a vacuum of one-20th of atmospheric pressure, developing a large-scale and efficient turbine, and so on).<sup>44</sup>

**TABLE 2**  
Ocean thermal energy conversion (OTEC)-related patents since 1990

- 
1. 'Condenser and the way of condensation for the OC type OTEC', applied for by the Director of the AIT of MITI on 9 April 1992, No. 4-116963
  2. 'OTEC appliances', applied for by the Toshiba Electrical Co. on 8 June 1992, No. 4-147063
  3. 'Thermoelectric appliances for the environmental protection', applied for by N. Sawada on 7 November 1992, No. 4-339422
  4. 'OTEC generators', applied for by S. Konno on 24 December 1992, No. 4-94440
  5. 'Thermoelectric appliances for the environmental protection', applied for by N. Sawada on 17 February 1998, No. 5-67293
  6. 'The utilisation of deep subsurface water', applied for by the Mitsui Shipbuilding Co. on 23 August 1993, No. 5-207540
  7. 'OTEC apparatus', applied for by the Chancellor of Saga University on 22 September 1993, No. 5-236432
  8. 'The system for the purification of water', applied for by the Nakamura Electrical Co. on 9 March 1994, No. 6-66567
  9. 'A generating system', applied for by the Mitsubishi Heavy Industry Co. on 11 April 1994, No. 6-72043
  10. 'Heat transmission pipe', applied for by the Matsushita Reiki Co. on 19 May 1994, No. 6-105437
  11. 'The deep subsurface water intake', applied for by the Taiyo Plant Co. on 21 June 1994, No. 6-173075
  12. 'The energy conversion apparatus', applied for by the Chancellor of Saga University on 20 September 1994, No. 6-224918
  13. 'Fluid transfer device', applied for by the Hitachi Electrical Co. & the Chubu Electrical Co. on 29 June 1995, No. 7-163360
  14. 'OTEC system', applied for by the OTEC Development Co. on 7 June 1996, No. 9-501395
  15. 'The method of fresh water production by the OC type OTEC', applied for by the President of the AIT of MITI on 27 November 1996, No. 8-316533
  16. 'The best mix system of natural energy', applied for by the Nihon Steel Co. on 18 September 1997, No. 9-253438
  17. 'The intake pipe of deep subsurface water', applied for by K. Daifuku on 25 February 1998, No. 11-241788
  18. 'The pumping of deep subsurface water, etc.', applied for by the Trio Marine Tech Co. on 13 November 2000, No. 2000-345226
- 

Source: Produced from the data base provided by the Patent Office of MITI.

As far as the utilization of OTEC technology is concerned, these two points are the bright side of the resurgence of OTEC development starting in the 1990s. What is noteworthy in both points, however, is the fact that there is a decisive transformation of the purpose OTEC was designed to serve. As for the 'spin-off' effects evident in the vast range of objectives of OTEC-related patents in Table 2, none of these effects serves the production of electricity at all, not to speak of the originally conceived purpose of OTEC as a trump card that would solve massive energy resource problems. As for the change of the OTEC type from CC to OC, it is true that the production of electricity is still kept alive as a purpose, but this purpose is completely different from the originally conceived one; that is to say, it is distinct from a solution to resource problems.

The individual aims of the two OC-related patents in Table 2 (patents 1 and 15) demonstrate this point. Patent 1 in the table states:

Medium-sized OC OTEC is feasible and still worthy of pursuing not only because of its medium scale production of electricity but also because of its valuable byproducts such as fresh water for drinking and industrial use. The practical use of OC is particularly promising as a means to the provision of electricity for remote islands and/or the provision of fresh water.<sup>45</sup>

Patent 15 likewise states: 'The patent aims at the provision of a more efficient apparatus for and method of fresh water production by OC OTEC which has the advantageous capability of producing fresh water as well as electricity.'<sup>46</sup>

In short, it is precisely through the reversal of the means–end relationship in OTEC development that the resurgence of OTEC development during the 1990s and after becomes viable and promising. While in its original context OTEC was expected to be a means to a given end, namely providing a solution to resource problems, in the present context the given means, such as various elementary technologies and the switch to OC, have created brighter prospects for OTEC by finding proper ends well-suited to those means.

In general it is fairly easy to make an independent, large-scale, long-term technological development project of any kind into a success story by removing the originally conceived purpose and inventing a new one that the technology at a later time can serve. If such a development project is to be evaluated other than in terms of global environmental assessment, careful and penetrating evaluation based on whether the project consistently put the original purpose into effect is the first thing to consider, unless a changing context removes the original purpose from long-term relevance. In the case of OTEC development there is no evidence to suggest that a changing context after the mid-1970s removed the resource problems stemming from the geopolitical condition of Japan.

Nevertheless the present context surrounding 'new energy' development in Japan tends to blur the originally conceived purpose. The supra-party draft plan of the Promotion Law for the Production of Electricity by

Natural Energy epitomizes the situation. The purpose of the law is stated as follows:

We need to build a society that contributes to a sustainable development enabled by economic growth with less environmental load. For that purpose it is necessary to stop global warming by controlling the emission of the gases contributing to the greenhouse effect and through the effective use of renewable energy resources. And measures taken for the promotion of electricity production making use of natural energy can meet both requirements simultaneously. This is the reason for proposing this draft plan.<sup>47</sup>

While mechanisms for pursuing 'new energy' technology development were the focus in the 'Sunshine' project, as the above quotation indicates, careful consideration of the global environment is now prominent in the draft plan. But now there is no longer any description of technological development for the solution of resource problems. The fact that the contribution of 'new energy' to Japan's total primary energy supply is only slightly above 1% (in 1998) should be enough for us to realize that the law is intended, not for replacing oil as an energy resource that accounts for more than 50% of Japan's total primary energy supply, but for reducing CO<sub>2</sub> emissions in accordance with the public pledge made in the Kyoto Protocol.<sup>48</sup> A request for the early passage of the Promotion Law for the Production of Electricity by Natural Energy made on 17 November 2000 clearly states that the intention of the law is 'to fulfil the public pledge made in the Kyoto Protocol'.<sup>49</sup> In addition, the share of renewable energy in both primary energy supply and R & D budget since the 1970s, which was when the 'Sunshine' project began, has surprisingly remained almost unchanged in Japan.<sup>50</sup>

These facts plainly mean that resource problems have not yet been solved in the way the 'Sunshine' project originally intended. A formalistic assessment of the success or failure of such projects has little meaning in sociological terms. The point in this particular connection is that OTEC development was able to continue for such a long time during and after the project, as the changing context surrounding the development fuelled and refuelled its momentum in spite of its failure to appropriately solve resource problems. This process is epitomized by the transformation of the originally conceived purpose, particularly by the reversal of the means-end relationship, when OTEC was revived in the 1990s. That is to say, the technological development adapted itself to changing circumstances. Such adaptation was a continuous process of legitimating the development in relation to the circumstances, first with the image of the 'trump card' for solving resource problems, and then later with the 'clean' image of the technology in relation to global environmental problems. And 'new energy' technology, particularly renewable energy technology in Japan such as OTEC, has provided a symbol well suited to such contexts of legitimation. Consequently, independent, large-scale, long-term technological development projects such as OTEC development tend to run continuously, once started, as if through their own inertia.

## Conclusion

The insights obtained from this examination of the relationship between technological development and global environmental problems by reference to the case of OTEC development in the 'Sunshine' project can be summarized in four points.

1. The 'Sunshine' project, which was set up to solve resource problems through environment-friendly initiatives, produced and published patents for OTEC using CFCs as the working fluid, even after the discovery of an ozone hole.
2. However, we cannot reduce the cause of this outcome simply to the failure of policy or inter-agency communication, since the relevant ministries and agencies had duly issued a preventive guideline to deal with stratospheric ozone depletion.
3. This case strongly suggests a hidden link between technological development and global environmental problems due to incomplete information at the time of assessment and/or decision-making. The development of a 'new energy' technology intended to solve resource problems created the possibility of damaging the stratospheric ozone, a possibility that was as yet unseen by the decision-makers at the time, and was still ignored when it became evident.
4. In this situation what is needed is a built-in mechanism to evaluate large-scale, independent, long-term technological development projects through reflexive 'feedback-for-learning' channels. This mechanism should be free from the network of interests of the agents who originally shaped the projects. This is because the function of the mechanism would be to prevent the fuelling and re-fuelling of the projects' momentum, which is made possible by transforming their originally conceived purposes in accordance with changing circumstances.

These conclusions are based on an intensive analysis of only one case, that of OTEC in the 'Sunshine' project. This analysis does not of course exhaust the sociological implications of the relationship between technological development and irreversible environmental change. The conclusions derived from the description and analysis of this single case do, however, contain unique implications worthy of discussion for the light they cast on the dynamics of the science–technology–society interface.

What is particularly important is the real need for an appropriate social framework within which a 'feedback-for-learning' channel for early detection of the intrinsic interconnection of completely different problems can work, rather than employing unsatisfactory 'fixes'. To design such social frameworks, it is necessary to determine how to allocate responsibility, in principle, for unanticipated consequences arising from big technological development projects.

The sociology of science and technology continues to uncover the complexity of the science–technology–society interface and to wrestle with

the notion of uncertainty. The precautionary principle (taking preventive measures before scientific evidence of actual harm is available) is one candidate for dealing with such uncertainty, and the Vienna Agreement in 1985 and the Montreal Protocol in 1987 both implemented that principle in an effort to take preventive measures against stratospheric ozone depletion.<sup>51</sup> However, when we look at the preventive measures taken in connection with the 'Sunshine' project, the sequence of events was reversed in Japan.

Admittedly, several proposals were made for policy implementation, and the related legislation was passed. As a move towards legal restriction of CFC production by the government, on 19 February 1988 the Central Council for Environmental Pollution Control set up within the Environment Agency submitted a report titled 'Basic System for Ozone Layer Protection'. On the same day, the Ozone Layer Protection Section of the Chemical Product Council in MITI also submitted a report titled 'Legal Restrictions on Chemical Production and Notes on Their Application in Japan'. Based on these reports, the Japanese Diet passed into law the Specific Substances Restriction Law for Ozone Layer Protection, in order to restrict the manufacture of designated CFCs and other related substances. The reports were made public in February 1988, the law was passed in May of the same year, and the restrictions took effect in July 1989. All this, however, came after patents using CFCs as the working fluid for OTEC had been applied for and published, and so at least until that time, the problem had been unnoticed or ignored.<sup>52</sup>

In addition, after the end of the 'Sunshine' project in 1992, patents resulting from OTEC development continued to be obtained and published, and they were given an 'environment-friendly' look by changing the proposed type of OTEC from CC to OC, and reversing the means-ends relationship in OTEC development. This ad hoc transformation makes it difficult to get a straightforward picture of the real place of environmental issues in the science-technology-society interface.

Thus, when the entire structure of problems is not available – or when it is available but ignored or is extremely difficult to see clearly due to the complex process linking science, technology and society at a particular time – the precautionary principle does not work. And the allocation of responsibility for events arising in a situation of uncertainty remains unresolved. In such an opaque situation, it is better to follow the principle of 'mild freezing' (low or zero growth rate) in the development of a new technology. According to this principle, the budget to be invested in the development of the technology in question can grow at a low or zero growth rate while an investigation is made and different agents concerned determine the necessary degree of caution based on investigation and negotiation. In other words, the principle of 'mild freezing' enables the agents concerned to change a particular path-dependent technological trajectory to another one when necessary to respect the precautionary principle.<sup>53</sup> With the principle of 'mild freezing', the allocation of responsibility is made by examining whether problems result from a particular

technological trajectory. With regard to ascribing responsibility, the principle of 'mild freezing' works from within the sphere of technology development, and the precautionary principle works from the 'outside' through regulation. In cases in which the use of technology is strongly contingent on a complex science–technology–society interface, so that initial decisions made in good faith are likely to generate irreversible environmental change, such a combination of 'mild freezing' from within and decisions based on the precautionary principle from without is crucial.

## Notes

The core idea of this paper was first presented at the USA–Japan seminar on mathematical sciences organized by Heisuke Hironaka. Earlier versions of the paper were read at seminars at the Science and Technology Policy Research Unit, University of Sussex, the Centre for Research into Culture and Technology, Brunel University, and the Centre Sociologie de l'Innovation, Ecole des Mines. I thank the participants of the seminars and the anonymous referees of this journal for their useful comments. Particular thanks are due to Daniel Kleppner, Mario J. Molina, Michael Lynch and Bruno Latour for their helpful suggestions and advice. Responsibility for the points made here including any errors is entirely mine.

1. One of the most noteworthy characteristics of global environmental problems is irreversible environmental change, such that once the environment has suffered from human influence in a particular way, it is extremely difficult for it to get back to its earlier state within a short period such as a lifetime of an individual person. A classical definition of irreversibility in social sciences can be found in Arrow & Fisher (1974). Despite the fact that social studies of science and technology have expanded into broad problem areas, detailed descriptions and analyses of global environmental problems by sociologists of science and technology are unexpectedly rare. For case studies of emerging global environmental problems that concern the formation of scientific disciplines, their dynamics, and relationships with policy, see Hart & Victor (1993) and van der Sluijs et al. (1998). For policy-oriented studies on global environmental problems and risk management, which are centred around various global environmental problems, including production and disposal of new chemicals, see, for example, Jasanoff (1985), Clarke (1989), Lowe & Ward (1998) and Miller & Edwards (2001). For literature on environmentalism, environmental philosophy, ecology, and various agents and pressure groups in environmental social movements, see, for example, Nelkin (1971), Elliot & Gare (1983), Milbrath (1984), Cramer (1987), Moore (1987) and Yearley (1996).
2. As will be detailed later, this does not mean that the project resulted from the oil crisis, because on 18 August 1973, about two months before the crisis, the Minister of International Trade and Industry had already inquired to the Industrial Technology Council, an advisory organ of the ministry, about how to advance the development of 'new energy' technologies to head off an energy crisis and ensure environmental protection. In addition, it was on 18 May 1973, about five months before the crisis, that the ministry's Agency of Industrial Technology decided to call for the establishment of a department for the development of 'new energy' (this department became the 'Sunshine' Project Promotion Headquarters when the project was started in July 1974). Apart from this earlier background of the project within the ministry, before the oil crisis the industrial sector increasingly called for a change to the oil-dependent energy policy. This resulted in a request for the revision of the policy in January 1973 by the Federation of the Economic Agency (Keidanren). See *Keidanren Geppo*, 21(1): 16–17. Thus the 'Sunshine' project should be understood as a product of two different factors: one was a demand for the development of 'new energy' technologies from within the governmental and industrial sectors, the other was the crisis, an external factor accelerating the move to answer these spontaneous voices.

3. Supplement to Official Gazette No. 14066 (14 November 1973: 10).
4. Quoted from the Clause 2 of the law (Law No. 37 enacted on 18 April 1997).
5. The foregoing descriptions are based on The 'Sunshine' Project Ten-Year Anniversary Committee of the Agency of Industrial Technology (abbreviated to AIT) (ed.), under supervision of the 'Sunshine' Project Promotion Headquarters of the Agency of Industrial Science and Technology, the Ministry of International Trade and Industry, '*Sunshine*' *Keikaku 10 Nen no Ayumi* (The Ten-Year History of the 'Sunshine' Project) (Tokyo: The 'Sunshine' project Ten-Year Commemorative Business Promotion Group/The Japan Industrial Technology Association, 1984: 16). At first, the organization was expected essentially to become the centre with overall control of 'new energy' development projects, but it gradually came to be a coordinating organization.
6. Even after adjustment is made for the increase in the wholesale price index during the period, the budget increase is still more than tenfold. Wholesale price index based on Keizai Kikakucho (Research Bureau of the Economic Planning Agency) (ed.), *Keizai Yorán* (Economic Catalogue).
7. For the development of energy efficient technologies, the Moonlight project was started in 1978 within MITI's ordinary large-scale projects. For the context of this technology development, see, for example, Watson (1997: chapter 8).
8. In 1977 OTEC for the first time came under the category of the integrated research (sogo kenkyu) of the 'Sunshine' project. From 1979 OTEC led development of 'new energy' technology, which itself began to have priority in that category of the project. See Industrial Technology Council, Shin Enerugi Gijutsu Kaihatsu no Susumekata ni tsuite (A Report on how to Advance the Development of 'New Energy' Technology) (January, 1974); *Annual Report of MITI* (1977): 235; *Annual Report of MITI* (1979): 240.
9. Research Centre for Marine Science and Technology (Kaiyo Kagaku Gijutsu Senta) of the Science and Technology Agency, Kaiyo Kagaku Gijutsu Senta, Wagakuni no Kaiyo Kaihatsu Vijiō to Kaiyo Kagaku Gijutsu Kadai ni kansuru Chosa Hokokusho (Report on the Ocean Development Programme and the Targets for Marine Science and Technology) (Tokyo: Kaiyo Kagaku Gijutsu Senta, 1978): 68.
10. Jacques A. d'Arsonval became a professor of the Collège de France in 1894. He is best known for his invention of the galvanometer.
11. As for the intricate relationship between different aspects of his career, see Blondel (1985).
12. J.H. Anderson and J.H. Anderson Jr, US Patent 3312054, 'Sea water power plant', Filed 27 September (1966), Serial No. 600287, Official Gazette, US Patent Office, 837, 1-2, 4 April (1967): 59.
13. Science Application International Corporation & Meridian Corporation under Contract No. DE-AC01-86CE30844 for DOE, Compendium of International Ocean Energy Activities, Draft (December 1988).
14. 'Sunshine' Keikaku ('Sunshine' Project), a brochure issued by the AIT in March 1987: 12.
15. The Electro-Technical Laboratory of the AIT, which was in charge of the development of component technology of OTEC, withdrew from OTEC-related researches in March 1997. A little earlier, in September 1994, the OTEC-related Study Group set up on 1 February 1988 independently of the 'Sunshine' project also dissolved. For this, see OTEC-related Study Group, Final Report (September 1994): 26.
16. Showa 61 Nendo Sunshine Keikaku Kenkyu Kaihatsu no Gaikyo (Sogo Kenkyu) (The Outline of Research and Development of the 'Sunshine' Project for Fiscal Year 1986) (Tokyo: Nihon Sangyo Gijutsu Shinko Kyokai, 1987): 6.
17. Idem: 2. Interpolation within parentheses by the author.
18. Showa 59 Nendo Sunshine Keikaku Seika Hokokusho Gaiyoshu (Sogo Kenkyu) (The Outline of Research and Development of the 'Sunshine' Project for Fiscal 1984) (Tokyo: Nihon Sangyo Gijutsu Shinko Kyokai, 1985): 25.
19. The passage within parentheses in the text is quoted from *Chiiki Reidanbo*, vol. 6, a brochure for promoting the sales of new technologies issued on 15 December 1975.

20. ECOR (Engineering Committee on Ocean Resources), Japan Marine Science and Technology Association (Japan National Committee for ECOR), *Ocean Energy Systems: Report of ECOR International Working Group* (February 1989): 85.
21. ECOR, *op. cit.* note 20, p. 63.
22. Kaijo Hoancho (ed.), *Showa 54 Nen Ban Kaijo Hoan Hakusho* (White Paper on Maritime Safety for Fiscal 1979), Appended Materials No. 24: 151.
23. The data are calculated from the number of sea rescues from 1976 to 1980 reported in Kaijo Hoancho (ed.), *Kaijo Hoan Hakusho* (White Paper on Maritime Safety).
24. Jukagaku Kogyo Tsushinsha Sekiyu Kagaku Ka (ed.), *Nihon no Sekiyu Kagaku Kogyo* (Petrochemical Industry in Japan) (Tokyo: Jukagaku Kogyo Tsushinsha), annual publication, 1980–90.
25. Provisional Company History Compilation Section of Asahi Glass Manufacturing Co., Ltd (ed.), *Asahi Garasu Shashi* (The History of Asahi Glass Manufacturing Co., Ltd) (Tokyo: 1967, for private distribution): 449.
26. CFC-11 and -12 were manufactured at that time. The company also started manufacturing CFC-22 in October 1966. *Idem*: 449–50.
27. Shigeyasu Nakanishi, 'Reibai mondai to reinetsu hassei no kouritsu nitsuite' (On Problems Caused by Coolant and its Efficiency), *Nihon Kikai Gakkai Gijutsu to Shakai Bunon Koen Ronbunshu*, No. 99–64 (21 November 1999): 16.
28. We may interpret this as a type of unanticipated consequence of action. 'Unanticipated consequence of action' here means both advantageous and disadvantageous consequences that were not anticipated at the time of decision-making by those agents concerned within the science–technology–society interface. For a classical formulation of an unanticipated consequence of action in sociology, see Merton (1936). This classical formulation of the concept contained nothing that particularly excluded nature and artefacts.
29. Based on the author's interview with S. Chubachi on 15 May 1997.
30. It was on 28 August 1986 that the first monitor map of an ozone hole produced from observations made by TOMS (Total Ozone Mapping Spectrometre) of Nimbus 7 was made public. See Stolarski et al. (1986). Nimbus 7 adopted a measurement programme designed to reject such an extraordinary ozone density value as one below 180 DU, if it were detected, so that it was inherently impossible to obtain observation data below that level. See Gribbin (1988). One DU corresponds to the amount in a 0.01 mm ozone layer when the amount of total ozone is measured at a pressure of one atmosphere and 0°C. It was only after the programme had been revised that the overall quantity of stratospheric ozone above Antarctica was found to have decreased about 20–40% on average in September and October 1979 to 1985 (Stolarski et al., 1986).
31. See Farman et al. (1985). According to their paper, the stratospheric ozone layer above Antarctica showed strange behaviour from 1957 to 1984, which overturned the results of the conventional computer simulation. The paper states: 'Recent attempts to consolidate assessments of the effect of human activities on stratospheric ozone (O<sub>3</sub>) using one-dimensional models for 30° N have suggested that perturbations of total O<sub>3</sub> will remain small for at least the next decade. Results from such models are often accepted by default as global estimates. The inadequacy of this approach is here made evident by observations that the spring values of total O<sub>3</sub> in Antarctica have now fallen considerably' (Farman et al., 1985: 207).
32. As mentioned earlier, S. Chubachi actually reported the same observation results about six months earlier.
33. It stated, 'The circulation in the lower stratosphere is apparently unchanged, and possible chemical causes must be considered', and ended with the following remark: 'An intensive programme of trace-species measurements on the polar-night boundary could . . . improve considerably the prediction of effects on the ozone layer of future halocarbon releases' (Farman et al., 1985: 210).
34. In fact, it greatly accelerated the movement to the total ban on release of CFC, which had begun to slow down with the advent of the Reagan administration.



35. White Paper (Kagaku Gijutsu Hakusho) on the Environment by the Environment Protection Agency (1981): 163. (The subtitle of this white paper is 'Seeking Total Environmental Preservation'.) In September 1980, the director of the Environment Agency organized a meeting on global environmental problems, which was made up of men of learning and experience. According to the 6th report of this meeting titled 'A Report of the Select Committee on the Environment and International Trade' (Kankyo to boeki ni kansuru tokubetsu iinkai hokoku) issued in April 1995, the term 'global environmental problems' is used to refer to two different sub-problems: one is 'global-scale environmental problems' such as global warming and stratospheric ozone depletion, the other is environmental problems extending beyond borders, such as acid rain. This paper uses the term to refer only to the former, since the two are different in the mechanisms through which they become social problems and in the means for their solution.
36. Supplement to *Official Gazette*, No. 14066 (14 November 1973: 10).
37. 'Tenki ni tatsu enerugi seisaku' (Energy Policy Facing Turning Point), *Keidanren Geppo*, vol. 18, no. 10 (1970): 28–41; 'Okina magarikado o mukaeta enerugi mondai' (Energy Problem Facing a Big Turning Point), *Keidanren Geppo*, vol. 20, no. 5 (1971): 14–31; et al.
38. 'Sekiyu o chushin tosuru enerugi seisaku nikansuru yobo' (The Call for Breaking Away from the Strongly Oil-Dependent Energy Policy), *Keidanren Geppo*, vol. 21, no. 1 (1973): 16–17.
39. The description of the reorganization of the Electrical Testing Laboratory into the Electrotechnical Laboratory is based on The 'Sunshine' Project Ten-year Anniversary Committee of the AIT (1984), op. cit. note 5; Jun Kikuchi, 'The "Sunshine" project' (unpublished documents, 1991).
40. Showa 59 Nendo Sunshine Keikaku Seika Hokokusho Gaiyoshu (Sogo Kenkyu) (The Outline of Research and Development of the 'Sunshine' Project for Fiscal Year 1984) (Tokyo: Nihon Sangyo Gijutsu Shinko Kyokai, 1985: 25–26).
41. As will be explained in more detail later, this sort of fade-out of a technological development is not problematized according to the criteria of success or failure. The criteria have been providing a framework for R & D management. See, for example, Morris & Hough (1987).
42. OTEC Research Association, Katsudo Keika Hokokusho (Report of Our Activities), September 1994: 26.
43. The description is based on The Agency of Natural Resources and Energies of MITI, Enerugi Gijutsu Senryaku Sakutei nikansuru Chosa Kenkyu (Report on the Strategic Policy of New Energy Technology Development), 2000: 14–15; < [www.ecology.or.jp/member5/agency/9805-3.html](http://www.ecology.or.jp/member5/agency/9805-3.html) > .
44. For a difficulty of this kind, see Avery & Wu (1994: 210–67).
45. Patents Record issued by the Patent Office of MITI, (A) 5-288481, 'Opun saikuru kaiyo onndosa hatsuden yono gyoshukusochi narabini gyoshukuhoho' (Condenser and Method of Condensation for the OC type OTEC): 2.
46. Patents Record issued by the Patent Office of MITI, (A) 10-159709, 'Opun saikuru kaiyo onndosa hatsuden yono tansuiseizo sochi narabini tansuiseizo hoho' (The Method of Fresh Water Production by the OC type OTEC): 1.
47. See < <http://www.jca.apc.org/~gen/houann.htm> > .
48. The contribution of 'new energy' to Japan's total primary energy supply is from Agency of Natural Resources and Energy of MITI (ed.), Sogo Enerugi Tokei (Energy Statistics); in 2001 the category of 'new energy' in the statistics was revised, resulting in a doubling of the 'new energy' figures, but the detailed criteria of the revision have not been publicly clarified.
49. Green Energy 'law' Network, 17 November 2000.
50. See Agency of Natural Resources and Energy of MITI (ed.), Sogo Enerugi Tokei (Energy Statistics); International Energy Authority, Energy Technology Research and Development Statistics, 1974–95.

51. Cases usually supposed to embody the principle include The Third Declaration on the North Sea (1990), Rio Agenda 21 Principle 15 (1992), and Wingspread Statement (1998). As for international politics in the protection of the ozone layer, see Benedick (1991). Extensive case histories of the precautionary principle can be found in Harremoës et al. (2002). According to M. MacGarvin, early warning in fisheries dates back to the 14th century (Harremoës et al., 2002: 24). For studies on the practical application of the principle, see, for example, McIntyre & Mosedale (1997) and Raffensperger & Tickner (1999).
52. For a general view of the Japanese scientific community on the ozone hole before this restriction by law took effect, see, for example, Tokushu: Nankyoku ozone hole (Special Issue: An Ozone Hole above Antarctica), *Tenki*, vol. 34, no. 1 (1987): 63–68; Kokuritsu Kyokuchi Kenkyujo, *Nankyoku no Kagaku, 3 Kisho* (Antarctic Science, 3 Climate) (Tokyo: Kokonshoin, 1988): 134–58.
53. The term ‘trajectories’ here broadly indicates the patterns of change specific to a certain area of science and technology. Apart from classical diffusion studies of technology (for example, Ogburn, 1946), there are two contexts in which the term is used. One is neo-Schumpeterian innovation studies, in which the term is broadly understood to mean technological change with economic effects within a certain sector. The other is studies of path-dependency, in which the term is more specifically understood as a stochastic process indicating a divergence of dominant technologies from an optimum pathway. What the extension of the term employed here shares with these two different contexts is the incalculable and/or unanticipated nature of change in the views of the parties involved at a given time. For a sociological study on a failure of technology trajectory in this sense, see Matsumoto (2000). For an example from neo-Schumpeterian innovation studies, see Dosi (2000). There are many other references relating to use of the term in this context, which are too numerous to list here. For a few of these, see Nelson & Winter (1982), Freeman & Soete (1990) and Rosenberg (1994). Studies on path-dependency originate in the pioneering studies by David (1985) and Arthur (1994). For recent developments relating to these two research traditions, see, for example, Ziman (2000). Works that coincided with these two research traditions can be found, for example, in Hughes (1983) and Basalla (1988).

## References

- Arrow, Kenneth J. & Anthony C. Fisher (1974) ‘Environmental Preservation, Uncertainty, and Irreversibility’, *Quarterly Journal of Economics* 88(2): 312–19.
- Arthur, W. Brian (1994) *Increasing Returns and Path Dependence in the Economy* (Ann Arbor, MI: The University of Michigan Press).
- Avery, W.H. & C. Wu (1994) *Renewable Energy from the Ocean: A Guide to OTEC* (Oxford: Oxford University Press).
- Basalla, George (1988) *The Evolution of Technology* (Cambridge: Cambridge University Press).
- Benedick, Richard E. (1991) *Ozone Diplomacy: New Directions Safeguarding the Planet* (Cambridge, MA: Harvard University Press).
- Blondel, Christine (1985) ‘Industrial Science as a “Show”: A Case-Study of George Claude’, in Terry Shinn & Richard Whitley (eds), *Expository Science: Forms and Functions of Popularisation, Sociology of the Sciences Yearbook, Vol. IX* (Dordrecht: D. Reidel): 249–58.
- Chubachi, Shigeru (1984a) ‘Preliminary Result of Ozone Observations at Syowa Station from February 1982 to January 1983’, *Memoirs of National Institute of Polar Research, Special Issue 34* (December): 13–19.
- Chubachi, Shigeru (1984b) ‘A Special Ozone Observation at Syowa Station, Antarctica from February to January 1983’, *Proceedings of the Quadrennial Ozone Symposium* (Halkidiki, Greece, 3–7 September): 285–89.
- Clarke, Lee (1989) *Acceptable Risk? Making Decisions in a Toxic Environment* (Berkeley, CA: University of California Press).

- Claude, Georges (1930) 'Power from the Tropical Seas', *Mechanical Engineering* 52(12): 1039–44.
- Cramer, Jacqueline (1987) *Mission-Oriented Ecology: The Case of Dutch Fresh-Water Ecology* (Amsterdam: Rodopi).
- David, Paul A. (1985) 'Clio and the Economics of QWERTY', *American Economic Review* 75(2): 332–37.
- Dosi, Giovanni (2000) *Innovation, Organization and Economic Dynamics* (Cheltenham, Glos.: Edward Elgar).
- Elliot, Robert & Arran Gare (eds) (1983) *Environmental Philosophy: A Collection of Readings* (Milton Keynes, Bucks.: Open University Press).
- Farman, J.C., B.G. Gardiner & J.D. Shanklin (1985) 'Large Losses of Total Ozone in Antarctica Reveal Seasonal ClO<sub>x</sub>/NO<sub>x</sub> Interaction', *Nature* 315 (16 May): 207–10.
- Freeman, Christopher & L. Soete (eds) (1990) *New Explorations in the Economics of Technical Change* (London: Pinter).
- Gribbin, John J. (1988) *The Hole in the Sky: Man's Threat to the Ozone Layer* (London: Corgi Books).
- Harremoës, Poul, David Gee, Malcolm MacGarvin, Andy Stirling, Jane Keys et al. (eds) (2002) *The Precautionary Principle in the 20th Century* (London: Earthscan Publications Ltd).
- Hart, David M. & David G. Victor (1993) 'Scientific Elites and the Making of US Policy for Climate Change Research, 1957–74', *Social Studies of Science* 23(4): 643–80.
- Hughes, Thomas P. (1983) *Networks of Power: Electrification in Western Society, 1880–1930* (Baltimore, MD: Johns Hopkins University Press).
- Jasanoff, Sheila (1985) *Controlling Chemicals: The Politics of Regulation in Europe and the U.S.* (Ithaca, NY: Cornell University Press).
- Kajikawa, Takenobu (1981) 'Kaiyo Ondosa Hatsuden-Nodosa Hatsuden' (OTEC and Energy Conversion using Salinity Gradient), *Oyo Butsuri* 50(4): 415–23.
- Kamogawa, Hiroshi (1978) 'Shigen Mondai Kaiketsu notameno Kaiyo Ondosa Hatsuden' (OTEC for Solving Resource Problems), *Keidanren Geppo* 26(5): 76–82.
- Komiya, Y. (1988) 'Furon kisei mondai to nihon no taio' (CFC Control Problem and Actions taken by Japan), *Kogai to Taisaku* 24(3): 45–53.
- Lowe, Philip & Stephen Ward (eds) (1998) *British Environmental Policy and Europe: Politics and Policy in Transition* (London: Routledge).
- McIntyre, Owen & Thomas Mosedale (1997) 'The Precautionary Principle as a Norm of Customary International Law', *Journal of Environmental Law* 9(2): 221–41.
- Matsumoto, Miwao (1998) *Kagaku Gijutsu Shakaigaku no Riron* (The Sociology of the Science – Technology – Society Interface) (Tokyo: Bokutakusha Publishing Co.).
- Matsumoto, Miwao (2000) 'A Hidden Pitfall in the Path of Prewar Japanese Military Technology', *Transactions of the Newcomen Society for the History of Engineering and Technology* 71(2): 305–25.
- Merton, Robert K. (1936) 'The Unanticipated Consequences of Social Action', *American Sociological Review* 1: 894–904.
- Milbrath, Lester W. (1984) *Environmentalists: Vanguard for a New Society* (Albany, NY: State University of New York Press).
- Miller, Clark A. & Paul N. Edwards (eds) (2001) *Changing the Atmosphere: Expert Knowledge and Environmental Governance* (Cambridge, MA: MIT Press).
- Molina, M.J. & F.S. Rowland (1974) 'Stratospheric Sink for Chlorofluoromethanes: Chlorine Atomic-Catalyzed Destruction of Ozone', *Nature* 249 (28 June): 810–12.
- Moore, N.W. (1987) *The Bird of Time: The Science and Politics of Nature Conservation* (Cambridge: Cambridge University Press).
- Morris, Peter W.G. & George H. Hough (1987) *The Anatomy of Major Projects: A Study of the Reality of Project Management* (Oxford: Major Projects Association, Templeton College, University of Oxford).
- Nelkin, Dorothy (1971) *Nuclear Power and Its Critics: The Cayuga Lake Controversy* (Ithaca, NY: Cornell University Press).

- Nelson, Richard & Sidney G. Winter (1982) *An Evolutionary Theory of Economic Change* (Cambridge, MA: Harvard University Press).
- Ogburn, William F. (1946) *The Social Effects of Aviation* (Boston, MA: Houghton Mifflin Co.).
- Raffensperger, C. & J. Tickner (eds) (1999) *Protecting Public Health and Environment: Implementing the Precautionary Principle* (Washington, DC: Island Press).
- Rosenberg, Nathan (1994) *Exploring the Black Box: Technology, Economics, and History* (Cambridge: Cambridge University Press).
- Stolarski, R.S., A.J. Krueger, M.R. Schoeberl, R.D. McPeters, P.A. Newman & J.C. Alpert (1986) 'Nimbus 7 Satellite Measurements of the Springtime Antarctica Ozone Decrease', *Nature* 322 (28 August): 808–11.
- Takazawa, Hiroyuki, Masakatsu Amano, Samuela Tukan & Tadayoshi Tanaka (1997) 'Kanshoiki niokeru Takinokata Kaiyo Ondosa Enerugi Riyo Shisutemu no Kenkyu' (Study on Multi-Function OTEC Utilization System for Coral Reef Area), *Bulletin of the Electrotechnical Laboratory* 61(9): 11–16.
- Uehara, Haruo (1977) 'Kaiyo Ondosa Hatsuden no Genjo to Gijutsuteki Kadai' (Current Status and Technological Aspects of OTEC), *Kikai no Kenkyu* 29(9): 1025–31.
- Van der Sluijs, Jeroen, Josée van Eijndhoven, Simon Shackley & Brian Wynne (1998) 'Anchoring Devices in Science for Policy: The Case of Consensus around Climate Sensitivity', *Social Studies of Science* 28(2): 291–323.
- Watson, W. James (1997) *Constructing Success in the Electric Power Industry: Combined Cycle Gas Turbines and Fluidised Beds*, DPhil Thesis in Science and Technology Policy, The Energy Programme, SPRU, University of Sussex.
- Yearley, Steven (1996) *Sociology, Environmentalism, Globalization* (London: SAGE Publications).
- Ziman, John (ed.) (2000) *Technological Innovation as an Evolutionary Process* (Cambridge: Cambridge University Press).

**Miwao Matsumoto** is Professor of Sociology at the Department of Sociology, University of Tokyo. His books include *The Failure of the Science–Technology–Society Interface* (Tokyo: Iwanami Shoten Publishers, 2002, in Japanese). His latest book is *Technology Gatekeepers for War and Peace: The British Ship Revolution and Japanese Industrialization* (Basingstoke: Palgrave Macmillan, 2005). He is currently exploring theoretical frameworks to analyse the path-dependent dynamics of the social decision-making process with particular reference to the diffusion of wind turbines and of human genome research.

**Address:** Department of Sociology, University of Tokyo, Hongo 7-3-1 Bunkyo-Ku, Tokyo 113-0033, Japan; fax: +81 3 5841 8930; email: [GHC03207@nifty.ne.jp](mailto:GHC03207@nifty.ne.jp)