

Technology and Terminology of Knapped Stone



**M.-L. Inizan
M. Reduron-Ballinger
H. Roche
J. Tixier**

Translated by
J. Féblot-Augustins

CREP

Technology and Terminology of Knapped Stone

Préhistoire de la Pierre Taillée

Published by Cercle de Recherches et d'Etudes Préhistoriques
Maison de l'Archéologie et de l'Ethnologie (Boîte 3)
21, allée de l'Université - 92023 Nanterre Cedex - France

Tome 5

In the same collection

- Tome 1 - Terminologie et Technologie (out of print)
- Tome 2 - Economie du débitage laminaire
- Tome 3 - Technology of Knapped Stone (out of print)
- Tome 4 - Technologie de la Pierre Taillée

Technology and Terminology of Knapped Stone followed by a multilingual vocabulary (Arabic, English, French, German, Greek, Italian, Portuguese, Spanish) / Marie-Louise Inizan, Michèle Reduron-Ballinger, Hélène Roche, Jacques Tixier, translated by Jehanne Féblot-Augustins. Nanterre : C.R.E.P., 1999 – 191 pages : 80 ill. ; (*Préhistoire de la Pierre Taillée* ; 5).
ISBN 2-903516-05-7

ISBN 2-903516-05-7
© CREP 1999

Cover : © J. Tixier

**Préhistoire de la Pierre Taillée
Tome 5**

Technology and Terminology of Knapped Stone

**Followed by a multilingual vocabulary
Arabic, English, French, German, Greek, Italian, Portuguese, Spanish**

**Marie-Louise Inizan
Michèle Reduron-Ballinger
Hélène Roche
Jacques Tixier**

Translated by Jehanne Féblot-Augustins

Nanterre : CREP

1999

Authors

Marie-Louise Inizan*, Michèle Reduron-Ballinger**, H  l  ne Roche*, Jacques Tixier*

Translation

Jehanne F  blot-Augustins*

*UMR Pr  histoire et Technologie - CNRS

**UMS 844 - CNRS

Maison de l'Arch  ologie et de l'Ethnologie (Bo  te 3)

21, all  e de l'Universit  

92023 Nanterre Cedex, France

roche@mae.u-paris10.fr

Acknowledgments

We thank O. Bar Yosef, L. Bourguignon, J.-P. Brugal, M. Charleux, M. Dauvois, J. Jaubert, J.-G. Marcillaud, L. Meignen, A. Morala, A.-M. and P. P  trequin, P.-J. Texier B. Vandermeersch, for allowing the reproduction of documents, sometimes unpublished.

We also thank I. Johnson for translating the first half of chapter 7 and B. Lequeux for her help during the preparation of this book.

Contents

List of illustrations	8
Foreword	11
Introduction : Technology	13
Chapter 1 : Raw materials	19
Knapped hard rocks	19
1. Mineralogy	19
2. Knapping suitability of hard rocks	21
2.1. An experimenter's viewpoint	21
2.2. Heat treatment of raw materials	23
Raw material procurement strategies	25
1. Provenance of raw material	26
2. Local availability of raw material	26
3. Transport to the campsite	26
Chapter 2 : Knapping	29
Intentional knapping	29
Knapping : shaping, flaking, retouching	30
Knapping methods and techniques	30
The main techniques	30
1. Percussion	30
2. Pressure	32
Knapping products	32
1. Describing a flake	33
2. Characteristic flakes	34
3. Knapping waste products	34
4. Knapping accidents	34
4.1. Breaks	34
4.2. Plunging flakes	36
4.3. Hinged flakes	36
4.4. Miscellaneous	36
Chapter 3 : Shaping	43
Bifacial shaping	44
1. Methods	44
2. Techniques	44
3. Morphologies	45
Polyhedral and spheroidal shaping	49
Other shaping methods	51
Preforms	51
The cleaver : a very specific tool	55

Chapter 4 : Debitage	59
The core	59
Debitage products	60
Debitage methods	60
1. Simple debitage.....	61
2. Predetermined debitage	61
2.1. The Levallois methods.....	61
2.2. The Kombewa method.....	68
2.3. Blade debitage.....	71
Percussion debitage of blades	73
Pressure debitage of blades	76
 Chapter 5 : Retouching	 81
Definition	81
Characteristics.....	81
Orientation of tools.....	82
Special techniques and their products.....	82
1. Microburin blow technique	82
2. Burin blow technique	84
3. Tranchet blow technique	85
4. Clactonian notch technique	85
5. Other techniques	85
 Chapter 6 : Technology as a means to an end	 89
Reading a stone object.....	89
1. Observation of surface conditions.....	91
2. Type of surface conditions	91
2.1. Natural alterations	91
2.2. Mechanical devices.....	92
2.3. Humanly induced alterations	92
2.4. Additions	93
3. Framework for the reading of a knapped stone object.....	93
3.1. Observation of surface conditions.....	93
3.2. Characterization of the raw material	93
3.3. Identification of the blank, if recognizable	93
3.4. Special knapping techniques	93
3.5. Description of removals by means of their main characteristics	94
3.6. Defining the object whether it be a tool or not	94
Understanding a lithic assemblage.....	94
1. Conjoins and refits.....	94
2. Knapping experiments	96
3. Traces of use	98
4. Technical behaviour.....	99
4.1. Assessment	99
4.2. Interpretation	10
 Chapter 7 : Graphic representation	 101
Planning.....	101
1. What to draw.....	101
2. How to draw	102

Drawing	102
1. General principles.....	102
2. Layout conventions	105
3. Description of the object.....	108
3.1. Views	108
3.2. Sections and section views.....	110
4. Graphic design and technique.....	111
4.1. Drafting	111
4.2. Pencil drawing	111
4.3. Pen and ink drawing.....	114
5. Materials and surfaces.....	114
5.1. Raw materials	114
5.2. Natural surfaces	116
5.3. Alterations.....	120
5.4. Additions.....	120
6. Symbols	121
Assessing.....	123
1. Scale.....	123
2. Orientation	124
3. Descriptive views	124
4. Removals	125
5. Symbols	125
6. Style of drawings.....	125
Schematizing	125
1. Schematic representation of an object.....	125
2. Schematic representation of a <i>chaîne opératoire</i>	126
Chapter 8 : Terminological Lexicon.....	129
Bibliography.....	159
Multilingual Vocabulary.....	169
English/Arabic — Arabic/English.....	171
English/French — French/English	174
English/German — German/English	177
English/Greek — Greek/English.....	180
English/Italian — Italian/English.....	183
English/Portuguese — Portuguese/English.....	186
English/Spanish — Spanish/English.....	189

List of illustrations

- Fig. 1 Raw materials
- Fig. 2 Knapping suitability tests
- Fig. 3 Raw material procurement strategies
- Fig. 4 Knapping techniques
- Fig. 5 Main descriptive terms for flakes
- Fig. 6 Large blade with multiple breaks
- Fig. 7 Experimental knapping accidents
- Fig. 8 Bifacial shaping of an arrowhead
- Fig. 9 Blade debitage carried out on a core with a single striking platform
- Fig. 10 Blade debitage carried out on a core with two opposite striking platforms
- Fig. 11 Bifacial and bilateral equilibrium planes of an handaxe
- Fig. 12 Various examples of bifacial shaping
- Fig. 13 Example of bifacial shaping
- Fig. 14 Bifacial-shaping flakes
- Fig. 15 Point of balance or point of gravity (point G) in polyhedral and spheroidal shaping
- Fig. 16 Polyhedral and spheroidal shaping
- Fig. 17 Trihedral shaping
- Fig. 18 Preforms
- Fig. 19 Phonolite cleaver
- Fig. 20 Main descriptive terms for cores
- Fig. 21 Relatively simple debitage
- Fig. 22 Volumetric representation of two Levallois debitage methods
- Fig. 23 Levallois debitage of a preferential flake
- Fig. 24 Recurrent centripetal Levallois debitage
- Fig. 25 Debitage of a Levallois point
- Fig. 26 Various examples of Levallois products
- Fig. 27 Debitage of a Kombewa flake
- Fig. 28 Phonolite cleaver on a Kombewa flake
- Fig. 29 Various types of blade-cores produced by percussion
- Fig. 30 Experimental blade and bladelet debitage positions
- Fig. 31 Pressure debitage of blades (or bladelets), different types of cores
- Fig. 32 The Yubetsu method
- Fig. 33 Microburin blow technique
- Fig. 34 Various examples of special techniques
- Fig. 35 Thermal damage
- Fig. 36 Refitting
- Fig. 37 Acheulean handaxe
- Fig. 38 Various examples of debitage products
- Fig. 39 Pressure-flaked bladelet-core, subsequently percussion-flaked
- Fig. 40 Refitting
- Fig. 41 Examples of orientation
- Fig. 42 Views used in lithic illustration (French system)
- Fig. 43 Two layouts of views. 1: French system. 2 : American system
- Fig. 44 Different ways of describing the volume of an object
- Fig. 45 The stages involved in the drawing process
- Fig. 46 Tracing the outline and the arrises
- Fig. 47 Uncompleted laurel leaf
- Fig. 48 Graphical treatment of various raw materials
- Fig. 49 Graphical rendering of the texture of various materials
- Fig. 50 Large convex Mousterian sidescraper on a frost-fractured flake

- Fig. 51 Proximal fragment of a Canaanite blade bearing traces of gloss and bitumen
- Fig. 52 Symbolic conventions in figurative drawings
- Fig. 53 Illustration of the main symbols used
- Fig. 54 Schematic representation of an object
- Fig. 55 Schematic representation of a *chaîne opératoire*
- Fig. 56 Angle of removals
- Fig. 57 Various examples of simple burins
- Fig. 58 Surfaces liable to be used as striking or pressure platforms for burin blows
- Fig. 59 Various examples of multiple burins
- Fig. 60 Inclination of a burin facet to the lower face of a blade
- Fig. 61 Schematic illustration of the main types of burin spalls
- Fig. 62 Various types of butts
- Fig. 63 Fluting experiment
- Fig. 64 Schematic illustration of blade debitage on a crested core
- Fig. 65 Delineation of the edge created by a series of removals
- Fig. 66 Distribution of removals along an edge
- Fig. 67 Extent of removals
- Fig. 68 Thermally treated and subsequently pressure-retouched flint blade
- Fig. 69 Localization of removals, various examples
- Fig. 70 Morphology of removals
- Fig. 71 Examples of oblique covering parallel retouch
- Fig. 72 The stone-knapper's set of tools for percussion
- Fig. 73 The stone-knapper's set of tools for pressure
- Fig. 74 Various examples of plunging blades and flakes
- Fig. 75 Position of removals
- Fig. 76 Examples of preparation
- Fig. 77 Core tablet and rejuvenation flake
- Fig. 78 Proximal fragments of pressure-flaked obsidian bladelets, showing traces of rubbing down on their upper faces
- Fig. 79 Various examples of sharpening on simple burins
- Fig. 80 "Siret" accidental break

Foreword

Many students and researchers have felt the need for an up-to-date guide to the jungle of prehistoric worked stone, either for professional purposes or from personal curiosity.

The qualities of worked stone, in addition to its imperishable nature and its use since the dawn of prehistoric time, certainly confer a special status on it until its replacement by more versatile materials such as metals. Nevertheless, it would be a mistake to think that stone-working contributes to the understanding of past behaviour for prehistoric societies alone. The abundance of easily available raw materials as well as the existence of technical expertises allowed the use of worked stone to continue into historical time. The true decline in the use of worked stone seems to coincide with the appearance of iron. However, let us not overlook gun flints and tinderboxes, nor the threshing sledge (*tribulum*), still in use today in agriculture.

The first French edition of *Préhistoire de la pierre taillée* in 1980¹ contributed to a renewal in the interpretation of lithic assemblages from a technical viewpoint. It included the terminological lexicon published by one of the authors in 1963², and translated by M. Newcomer in 1974³, which was relatively rudimentary and still oriented more towards typology than technology.

In 1992, a new edition, in English⁴, gave us the opportunity to take into account recent advances in understanding the technology of knapped stone, as much from a theoretical standpoint as in archaeological applications. Like the earlier editions, it was intended as a basic reference book for as wide a public as possible. A multilingual lexicon in eight languages was appended, written by prehistorians in their own mother-tongues, which should ease communication and subsequently enrich the field of technology.

The new 1995 French edition⁵, of which this latest English edition is the unabridged translation, was entirely revised; amongst other additions, a chapter devoted to graphic expression was included, being essential to communication in technological studies. The multilingual lexicon (with Portuguese added)⁶ is of course appended to the present edition.

1 Tixier, Inizan, Roche, 1980.

2 Tixier, 1963.

3 Tixier, 1974.

4 Inizan, Roche, Tixier, 1992.

5 Inizan, Reduron, Roche, Tixier, 1995.

6 Fellow prehistorians kindly took on this task : **Joachim Hahn** (Tübingen University) wrote the German text, **Sultan Muhesen** (Director of Antiquities and Museums of Syria) the Arabic text, **Sergio Ripoll** (Madrid, National University “a Distancia”) the Spanish, **Antiklia Moundrea** the Greek, **Daniella Zampetti** (Rome, University “La Sapienza”) the Italian, and **Luis Raposo** (Lisbon, National Museum of Archaeology) the Portuguese.

Introduction

Technology

The term technology is here reserved for a conceptual approach to prehistoric material culture, based on the reasoned study of techniques, including those of human physical actions. It is appropriate to recall that we are indebted to M. Mauss⁷ for this notion of technique *per se*, divorced from material objects, insofar as he considered bodily actions, such as dancing for instance, as techniques. Arguing along similar lines, A.-G. Haudricourt⁸ writes : “While the same object can be studied from different viewpoints, that which consists in defining the laws of creation and of transformation of an object is undeniably the most essential of all viewpoints. It is clear that the essential aspect of a manufactured object resides in the fact that it is made and used by man ; it is also clear that if technology is to be a science, it must be the science of human activities”.

Although the present essay is concerned solely with the technology of knapped stone, one should nevertheless bear in mind that technology encompasses the entire technical system at play in a culture. The study of knapped stone was very soon given prominence to in prehistory because lithics offer the earliest evidence of a well preserved technique. However, other studies soon followed, devoted amongst others to organic material culture, and to later achievements involving the use of fire, such as ceramics, metal, glass, etc.

The study of techniques does not lead to technology alone. Indeed, when establishing chronologies, archaeologists have always been concerned about the invention of techniques, their complexity, and their ability to identify a culture. Likewise, no typology can be fully operative if it does not take techniques into at least partial account. We do not therefore consider substituting technology for typology, for they represent two distinct approaches developed to meet different ends; they can however be used concurrently, and great benefit can be derived from the comparison of the results they yield.

Technological analysis must, in each and every circumstance, enable one to assess what pertains to deterministic constraints, before cultural choices are assumed.

⁷ Mauss, 1947.

⁸ “*Si l'on peut étudier le même objet de différents points de vue, il est par contre sûr qu'il y a un point de vue plus essentiel que les autres, celui qui peut donner les lois d'apparition et de transformation de l'objet. Il est clair que pour un objet fabriqué c'est le point de vue humain de sa fabrication et de son utilisation par les hommes qui est essentiel, et que si la technologie doit être une science, c'est en tant que science des activités humaines*”. Haudricourt, 1964 : 28.

Why?

Technology has its place within an original stream of French anthropological research, thanks to the pioneering work of A. Leroi-Gourhan. It has since then become an independent field of research in prehistory. A. Leroi-Gourhan⁹, who was by calling an ethnologist and subsequently a prehistorian, published in 1943 *L'homme et la matière*, the first volume of *Evolution et techniques*, a book that the successive generations of researchers discover anew with unabated interest. His entire work was dedicated to the quest for mankind through the study of technical, social or symbolic patterns of behaviour¹⁰. He held the Chair of Prehistoric Ethnology, created for him at the Collège de France, and over a period of many years the rigour of his teaching, within the framework of that institution as well as at the prehistoric site of Pincevent – a genuine research laboratory from 1964 onwards – has significantly widened the scope of scientific research in prehistory¹¹.

One of Leroi-Gourhan's original contributions was the concept of *chaîne opératoire*¹², which forms the basis of the approach to technology developed in this book. In the study of a lithic assemblage, the *chaîne opératoire* encompasses all the successive processes, from the procurement of raw material until it is discarded, passing through all the stages of manufacture and use of the different components. The concept of *chaîne opératoire* makes it possible to structure man's use of materials by placing each artefact in a technical context, and offers a methodological framework for each level of interpretation. An identical trend in French ethnology contributed to the emergence of a "school of cultural technology"¹³, which publishes the periodical *Techniques et culture*. This group helped both to rehabilitate the study of material culture, by demonstrating that any technical fact is a social or a cultural fact, and to widen the field of study of the technical system by showing the need to take into account all possible technical variants.

How?

A methodology

The procedures we have developed in our technological approach are applied solely to the analysis of knapped stone assemblages, and this is quite deliberate: the novel questions investigated by prehistorians-technologists have given rise to new lines of research that require operative methodological tools.

- The notion of technical system¹⁴: by treating stone-knapping as a sub-system¹⁵, one can readily see what insight can be gained into the history of a prehistoric group through the study of its techniques. Analysing the interdependence of different sub-systems brings a new level of inferences within reach: lithics endowed with such properties as cutting, boring, rasping, scraping, etc., fulfill a number of needs that are necessarily linked to specific activities, which

9 Leroi-Gourhan, 1943 and 1964.

10 "Sur le long chemin que doivent encore parcourir les sciences humaines avant qu'elles deviennent réellement la philosophie et, donc, avant de pouvoir nourrir réellement la philosophie, André Leroi-Gourhan est certainement un géant" ("On the long road that the human sciences have yet to cover before really becoming philosophy, and therefore before being really able to nurture philosophy, André Leroi-Gourhan is certainly a giant"). Cresswell, 1989 : 26.

11 M. Julien (1992) wrote an essay that examines the present state of the subject.

12 The term "*chaîne opératoire*" is considered from a technological standpoint; without attempting a definition of the concept, we shall try to show in what way it is operative. This French expression seems to be increasingly used by English-speaking technologists, as shown by volume 9 : 1 of the *Cambridge Archaeological Review*, which deals with *Technology in the Humanities*. It will therefore be left untranslated throughout the text.

13 Around R. Cresswell.

14 "*L'ensemble des techniques forme des industries et des métiers. L'ensemble : techniques, industries et métiers, forme le système technique d'une société*" ("Techniques as a whole generate industries and crafts. The set : techniques, industries and crafts, corresponds to the technical system of a society"). Mauss, 1947 : 29.

15 Perlès, 1987 : 22.

bring other sub-systems into play. It is by cross-examining the results of different analyses pertaining to the activities common actions involve, that we give greater substance to our interpretations; however, we are only just beginning to use the notion of technical system efficiently as a means of approaching the study of behaviour.

In such a perspective, knapped stone industries can be studied through a combination of identifiable elements such as tools, raw materials, physical actions and skills.

Tools (the term is used here in its broader sense and refers to the object of knapping operations) are given prominence to in typological studies; they are however narrowly dependant on raw materials, human physical actions and skills.

Raw materials belong to a geological context. Their knapping is ruled by specific laws pertaining to fracture mechanics, which vary according to the type of stone. Raw materials can be worked directly, or they can be structurally modified beforehand, notably by heat treatment.

Physical actions are linked to psychomotor functions : the hand and the body act according to orders transmitted by the brain, within the limits of human motor abilities.

Skills are the result of motor dexterities and cognitive capacities that operate in combination with knowledge; they can be assessed in terms of competences and performances¹⁶ (see p. 100). The transmission of skills involves a learning process, which can only take place between individuals within the social group; this collective knowledge can also be communicated to other groups. The analysis of skills is an essential prerequisite for the appraisal of technical facts in a given culture (ch. 6).

• Another notion concerns projects and the means by which they are implemented. Knapping activities are subtended by more or less elaborate projects, which can be apprehended through the reconstitution of the associated *chaînes opératoires*. In knapping operations, the **project** includes a **conceptual scheme**, of an intellectual nature, which is itself implemented through a series of operations termed **operative knapping scheme(s)**. Within a single *chaîne opératoire*, the relationships between conceptual and operative schemes, knowledge and skills, techniques and methods, are organized in the following way :

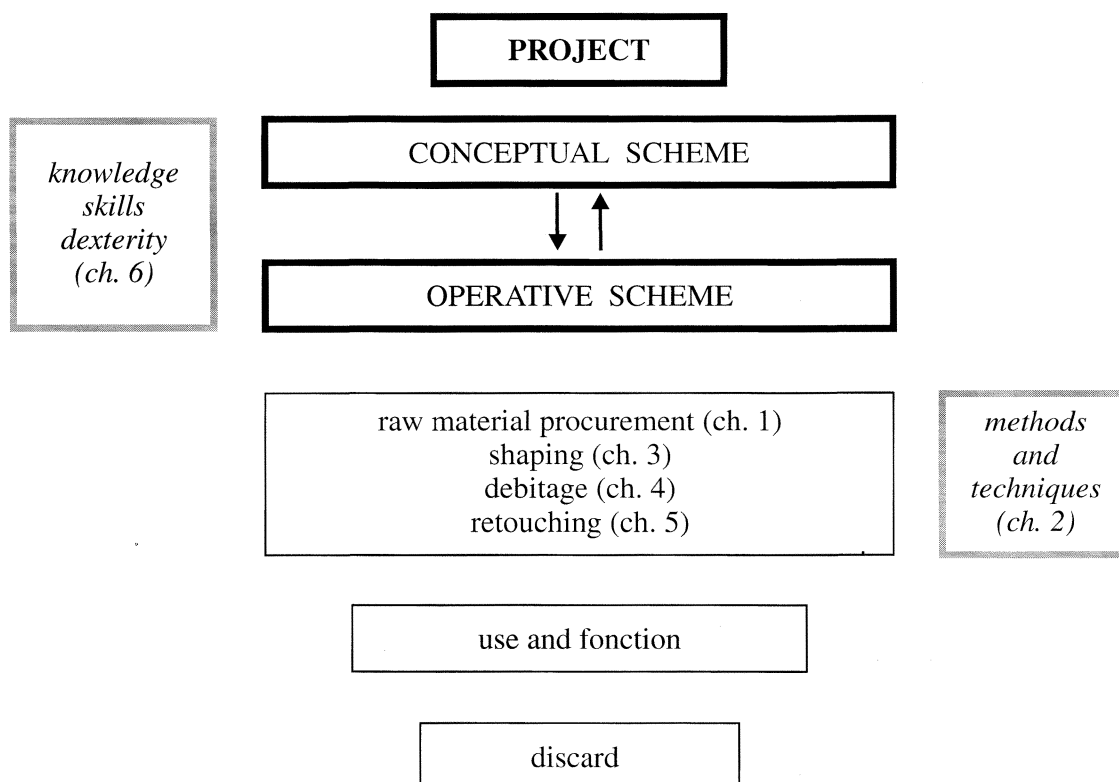

¹⁶ Pelegrin, 1995.

In blade debitage¹⁷, for instance, the project of the prehistoric knapper is easy to identify : his intent is to achieve elongated blanks of varied morphology. However, depending on the culture he belongs to, the knapper will use specific conceptual and operative schemes in order to carry out his project. To be able to demonstrate the existence of such schemes, one must register in detail all the pieces of information and show forth “regularities”¹⁸, first within one lithic assemblage and subsequently within others that are comparable. Indeed, without the repeated observation of phenomena, of similar facts, archaeologists have no basis for comparison and are limited to anecdotal evidence.

- Technology is also dedicated to the study of relationships between the technical system and socio-economic phenomena. This is one of the most fruitful and rapidly developing means of approaching prehistoric life-styles.

Knapped stone industries can be studied in terms of economy. By economy, we refer to a differential management of raw materials, blanks, or tools. For instance, if on a site yielding several raw materials the various types of tools have been made indiscriminately from any of the said raw materials, we do not have a case of raw material economy. Conversely, if it can be shown that choices were made, the term economy becomes relevant, and applies, depending on the case, to raw materials, to debitage products or to tools. The quality and availability of raw material must however be assessed before any assumption concerning the nature of the choices is made : before ascribing the use of microliths to a cultural choice, it is advisable to make sure whether or no the available raw material could allow the manufacture of larger tools. Any lithic industry can therefore be studied, as a whole, in such techno-economic terms, provided one bears in mind that technical variants may result from a cultural choice.

“Reading” stone objects

Reading takes place on two levels.

- The first level is that of observation, an initial reading of knapping scars. It involves the technical reading of each artefact (whether it be an ordinary flake or a waste product or the most elaborate tool) in order to assess its position in the *chaîne opératoire*, and is independant of the archaeological context. This chain, as we previously mentioned, encompasses not only the moment of manufacture of the artefact, but its subsequent use and discard, and in the first instance the procurement of raw material ; in fact, it includes the entire history of the artefact up to the moment of its analysis.

- The second level is one of inference. This is a matter of interpreting the interdependence of artefacts in the *chaîne opératoire*, even if links are missing. Presence or absence are significant in the context of interpretation. For instance, the absence or the low frequency of cortical flakes in a knapping workshop suggest that the raw materials were tested or roughed out elsewhere. Again, a blade workshop without blades is also conceivable ; the presence of characteristic products, such as cores and crested blades, is evidence enough of the activities and of the knapping project carried out at the site. Connections must also be sought between this second level of inference and the other technical activities stone-working involves.

The value of such inferences will be contingent not only upon the type of lithic remains brought to light, but also upon the recognition of techniques and methods, and consequently upon our own understanding of *chaînes opératoires*.

On a site, there may be evidence for just one *chaîne opératoire*, but more often there are many, corresponding with the different strategies brought into play by prehistoric people in the course of their various activities, or in the context of postponed activities. Whatever the case, all the phases of a *chaîne opératoire* are not necessarily represented on a site or on the excavated portion of a site.

17 In French, the term *débitage* (“debitage” in English) refers both to the action of flaking and to the tangible results (debitage products) of this action.

18 Gallay, 1986 : 115.

Terminology

The problem of a uniform descriptive vocabulary arises from the outset. Any reading of archaeological material would be pointless if it were not followed by exchange and communication.

Indeed, by acknowledging that words are tools¹⁹, we realize how much a precise vocabulary can improve the effectiveness of our analyses. Homage must once again be paid to A. Leroi-Gourhan : during his seminars on habitation structures (*lato sensu*) at the Collège de France, he initiated a process of collective reflection leading to the establishment of “a provisional vocabulary, in which the major concern was to eschew the pitfall of words and of uncontrolled identification”²⁰. The terminological lexicon presented here deals with the vocabulary of lithic technology. Many of the terms are conventional, and deliberately taken from terminology in current use. Even if they are not quite apt, they have become established by usage and are therefore convenient : stripped of their original meaning, they are already integrated into a specialized vocabulary (for instance, terms such as burin, microburin, Levallois, etc.).

The wish to untangle confusions, reduce synonymies and suppress ambiguities has guided our choices. We have avoided equivocal technical terms, and have tried to stick to a single term when describing the same phenomenon.

Lithic illustration

The same procedures have been applied to the illustration of lithics. Drawings should not be considered as a prop for words and definitions, but as a genuine informative technological writing, and this is what we have attempted (ch. 7). Far from being mere reproductions of stone artefacts, the drawings and diagrams presented here were conceived at the same time as the text and can even substitute for it, the symbols used being equivalent to a terminology. If a clear sentence is better than a vague generic term, an accurate technical drawing can usefully replace a vague description.

19 “However, I think it is important that researchers recognize that their words are their tools, just as stone artifacts they study were the tools of people”. Boksenbaum, 1977 : 30.

20 “*un vocabulaire d'attente, où dominait le parti d'échapper au piège des mots et de l'identification sans contrôle*”. Leroi-Gourhan, 1982 : 3.

Chapter 1

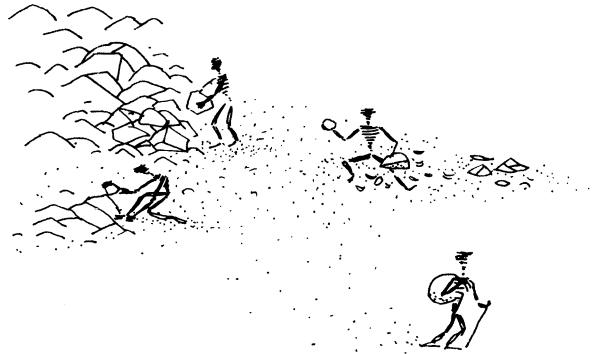

Raw materials

Knapped hard rocks

1. Mineralogy

Prehistoric people worked a large variety of raw materials, rocks mainly but also quartz, which is a mineral.

Knapped stones are connected with the geological context in which the earliest knappers moved about. Undoubtedly, choice of locations and movements across the territory were partly conditioned by prehistoric man's choices in matters of raw material use.

Although the varieties worked seem to form a collection of disparate types, the selection is coherent from the point of view of the mechanical properties of the rocks. They are exclusively homogeneous and isotropic materials, in which the spread of fracture fronts, initiating from a predetermined impact, is guided by the laws of distribution of constraints.

Without delving into the complexities of accurate mineralogical definitions, the four most common rock types used can be presented thus (fig. 1) :

- Sedimentary rocks, which include numerous varieties of flints (fig. 1 : 1, 2 and 7), cherts, some limestones, dolomitic rocks, sandstones, some jaspers that are genuine silicified pelites.
- Such igneous rocks as are characterized by a microlithic or vitreous texture. Barring some fine-grained granites and diorites, they are mainly extrusive rocks, whose crystallization has been prevented or stopped by rapid cooling. They include rhyolites, trachytes, andesites, basalts, phonolites (fig. 1 : 6), ignimbrites and obsidians (fig. 1 : 3 and 4).
- Metamorphic rocks such as quartzites (fig. 1 : 5).
- A mineral (tectosilicate) of hydrothermal origin, which crystallizes at low temperatures and comes as polymorphous varieties : hyaline quartzes (isolated crystal, fig. 1 : 8), milky quartzes (crystal agglomerate), chalcedonies and agates (a microcrystalline concretionary form of quartz, variously coloured or banded).

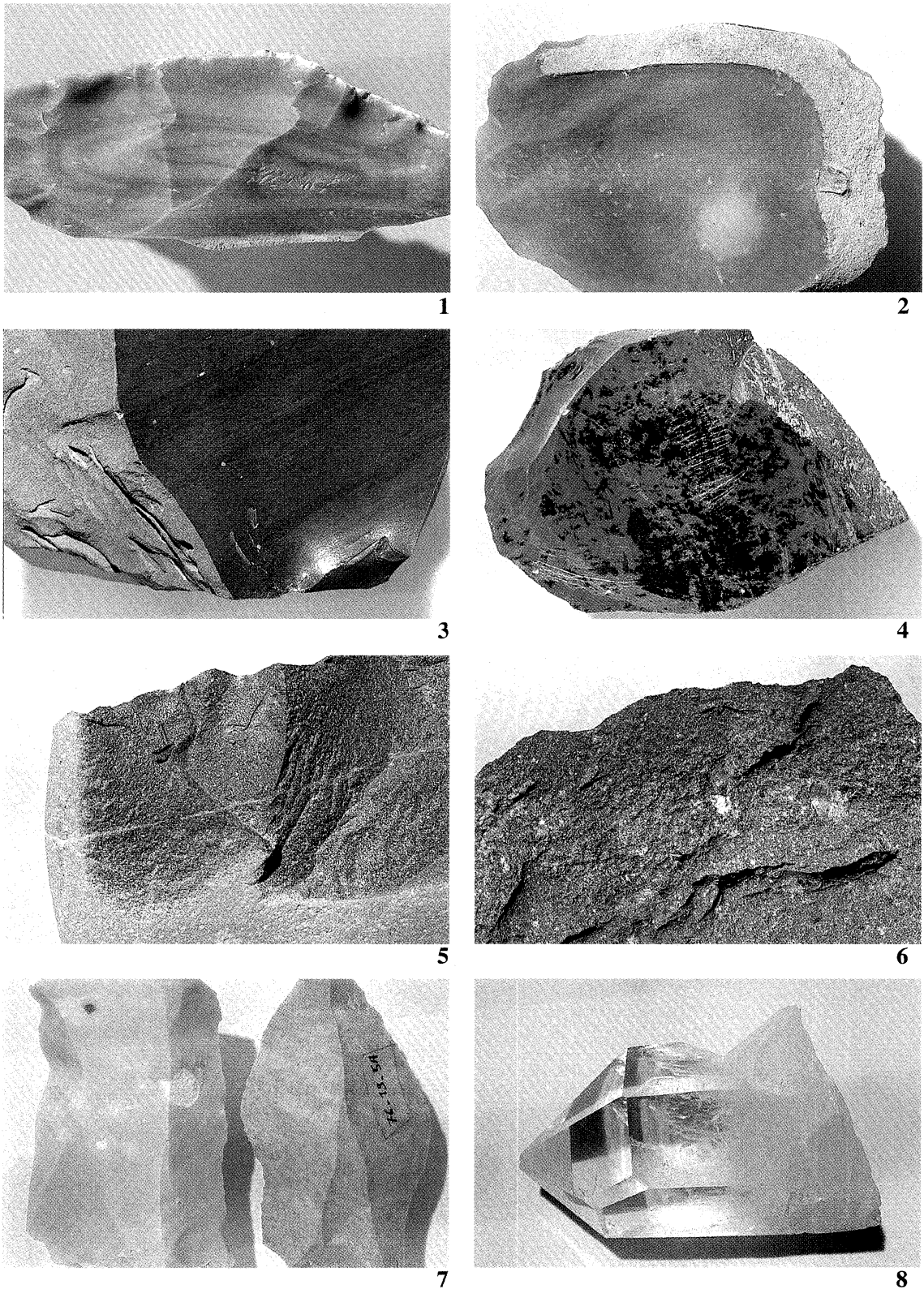

Fig. 1 — Raw materials. 1 : banded Bergeracois flint, Dordogne. 2 : Touraine flint. 3 : blue-black obsidian, Zinaparo, Mexico. 4 : black and red mottled obsidian, Oregon, U.S.A. 5 : burgundy-red quartzite, Tagus terraces, Portugal. 6 : grey-blue phonolite, Isenya, Kenya. 7 : putty-coloured Bergeracois flint, Dordogne, before and after heat treatment. 8 : hyaline quartz, Minas Gerais, Brazil (Atelier photo C.N.R.S., Meudon).

2. Knapping suitability of hard rocks

One should bear in mind that experimentation witnesses constant breakthroughs, and that the assessment of rocks' suitability for knapping progresses accordingly. Nevertheless, although we are perforce guided by what we currently know, our assessment of the knapping suitability of a particular rock must absolutely be based on experimental tests.

2.1. An experimenter's viewpoint

Prehistoric people worked all the raw materials at their disposal, testing, selecting and choosing them according to their knapping suitability, their abundance and their shape.

The following presentation of raw materials takes absolutely no account of mineralogical or petrographical classifications; it is based solely on the knapping characteristics of different rock types, appreciated in the course of experimental tests. The viewpoint of a single experimenter could well be considered empirical. However, allowances made for minor details, most modern stone-knappers come to similar conclusions, even though some of them may attain a higher degree of proficiency in certain techniques and methods.

The opinions professed here concerning a few dozen materials are therefore those of a single experimenter, whose motivations differ from prehistoric man's. This does not purport to be a comprehensive survey of the question, for the varieties of rocks knapped by prehistoric workers are countless.

One of the authors (J.T.) has applied the principle of trying out every conceivable technique on as many natural materials as possible (pressure and percussion debitage and retouching, using stone, bone, wood, antler, ivory, etc.); this led to many attempts, which were not however pursued over a long period of time. At the moment, we are far from having exhausted all the possibilities of systematic experimentation to further our understanding of knapped tools.

We shall not re-examine the physical qualities that cause a material to be good or bad, such as elasticity, homogeneity or fragility²¹. What we offer is a basic global appreciation, bearing in mind however that homogeneity is the main prerequisite for regular debitage (as in standardized blade production, for instance) or long retouches.

As a matter of fact, rocks can be placed on a continuum, and range from those with which "anything is possible" to those from which flakes can only be removed with difficulty. In order to clarify by simplifying, we propose three grades of suitability for knapping.

- Rocks that are very easy to work. These fall into two main categories : vitreous and fragile rocks, such as obsidian; non-vitreous and moderately fragile rocks, such as certain flints.
- Rocks that are quite easy to work.
- Rocks that are difficult to work.

These three grades are shown in the table (fig. 2), as well as those resulting from heat treatment; it seemed both convenient and effective to thus sum up experiments for the manufacture of :

- leaf-shaped bifacial pieces by percussion with a soft hammer;
- blades by direct percussion with a soft hammer, or by indirect percussion;
- blades by pectoral pressure with a crutch;
- long parallel retouches by pressure.

These appreciations must however be qualified.

- The properties of some rocks may allow the application of certain techniques, while few good results, if any, will be achieved when other techniques are applied. For instance, very good handaxes, or even good thin leaf-shaped bifacial pieces, can be made from sanukite, a variety of andesite from Japan. On the other hand, the removal of flakes proves difficult, and the extraction of blades by percussion is virtually impossible.

- A very few rocks require flaking "with the grain". For instance, the fossil wood from Tidikelt, in the Algerian Sahara, is much more easily worked if debitage follows the veins (fibres, in fact), which are still apparent - and that is precisely what the Aterians did.

21 Crabtree, 1967.

EXPERIMENTS RAW MATERIALS	bifacial pieces soft hammer	blades soft hammer	blades pressure	parallel retouch pressure	improvement heat treatment
Obsidian (U.S.A., Japan, Iceland, Italy, Turkey, Greece, Kenya, Ethiopia, Mexico, Guatemala, Ecuador)	++	++	++	++	-
Ignimbrite (U.S.A.)	++	+	+	++	-
Resinite (France)	+	+	/	+	-
Quartz Crystal, Amethyst (France, Brazil)	++	/	/	+	-
Translucent flint (France, England, Belgium, Denmark, Morocco, Algeria, Tunisia, Senegal, Lebanon, Qatar)	++	++	+	++	++
Opaque flint (Europe, Africa, South-West Asia, North and South America)	+	++	/	+	++
Chalcedony (France, Algeria, U.S.A.)	++	++	+	+	++
Jasper (France, Greece, U.S.A.)	++	++	/	++	-
Lydianstone (Algeria)	++	/	/	++	++
Opalite (France)	++	++	/	++	++
Agate (Egypt, SouthAfrica)	+	/	+	+	-
Green "dacite" (Tenere / Niger)	++	++	/	+	-
Silicified wood (U.S.A., Algeria, Niger)	+	+	/	-	++
Basalt (France, U.S.A., Brazil, Kenya)	+	-	/	+	/
"Sanukite" (Andesite) (Japan)	++	-	/	+	/
Quartzite, Sandstone (France,U.S.A., Algeria), Silicified "arenite" (Brazil)	++	+	/	+	/
Rhyolite (Algeria)	+	+	/	-	/
Siliceous limestone (France, U.S.A.)	+	+	/	/	-
Novaculite (U.S.A.)	+	/	/	-	++

Experiments :	Heat treatment
++ : very good	++: very much improved
+ : middling	+: improved
- : bad	-: not improved
/ : untested	/: untested

Fig. 2 — Knapping suitability tests.

- A single block of raw material may exhibit varying characteristics : the sub-cortical zones of some flints are perfectly suitable for the application of all techniques, whereas the inner stone is mediocre in quality.

It is actually impossible to generalize concerning the suitability of a particular kind of rock, such as flint for instance. And it is also sometimes difficult to voice a definite opinion about a regional type : the different outcrops or deposits yielding various sub-types must be examined (except in the case of river terraces) before any claim to accuracy can be made.

As a rule, when faced with an archaeological problem, one should never prejudge the quality of a rock worked by prehistoric people. Each variety of rock, or even each nodule, can be considered as a unique case. The solution must always be found through experimentation.

One should be careful not to be misled by materials whose knapping scars are difficult to read : they are not necessarily difficult to work. For instance, ripples and hackles are far less visible on a piece of coarse-grained quartzite than on a good homogeneous fine-grained flint. Both materials are however very easily worked.

The aesthetic value of an object, as we appreciate it with our twentieth century eyes and brain, is yet another matter where caution is required. Is a tool beautiful or ugly, well or badly made? Or was there simply no other possibility, owing to the constraints imposed by the nature of the raw material and considering that the tool meets the end it was intended for?

An experimenter's comments

- A rock must above all be homogeneous to be deemed suitable for knapping. As a direct consequence of lack of homogeneity, a seemingly high-grade lump of raw material can prove unworkable, except for the fashioning of very small pieces, owing to the presence of cracks or impurities (saccharoid nodules or feldspath crystals, bubbles, etc.). Frost induced internal joints and cracks are a particular hindrance when they are very common in a block, especially since they are not always immediately visible.

- A rock that rings clear wherever it is struck stands a good chance of being usable, and is in any case not frost-damaged.

- As a rule, the more translucent a rock, the greater its suitability, with the exception of rock crystal.

- There is little relation between the granularity of a rock and its suitability for knapping : some coarse-grained quartzites allow the production of leaf-shaped bifacial pieces.

- A piece of raw material from which large blades can be struck off by percussion allows the production of every shape attainable through percussion.

- The more elastic the rock, the easier pressure debitage becomes, obsidian being a case in point.

2.2. Heat treatment of raw materials

Although the great majority of rocks were used in their unaltered natural condition, a growing number of finds show that prehistoric knappers applied heat treatment to improve the quality of some raw materials and make knapping easier.

Long considered a Solutrean invention, which was not adopted (or so it seems) by later Upper Palaeolithic cultures, heat-treating was first recognized on pressure-retouched pieces. Experimentation has shown empirically that pressure-retouching of some types of siliceous rocks was clearly made easier by heating : flint responds very favourably to such treatment (removals split off more smoothly), whereas no (or little) improvement can be observed for quartzite, jasper, dacite, etc.²². Evidence for heat-treating in the case of pressure debitage has in recent years been claimed first for Neolithic cultures²³, but also for such cultures of the Siberian Upper Palaeolithic

²² Inizan, Roche, Tixier, 1975-76 : this paper was the first to bridge the gap between experimentation and archaeological observation. Later references include Griffiths *et al.*, 1987 ; Domanski, Webb, 1992 ; Borradaile *et al.*, 1993.

²³ Binder, 1984 ; Inizan, Lechevallier, 1985.

as used the said debitage technique²⁴. So far, the evidence concerns the production of bladelets alone; no blades and no blade-cores bearing witness to heat treatment have to this day been documented.

As with pressure debitage, we are indebted to D. Crabtree for the recognition of this technique²⁵, which consists in heating siliceous rocks such as flint, chert and chalcedony to a temperature lying between 250°C and 350°C (480°F and 660°F). During the Lithic Technology Congress held at Les Eyzies in 1964, this accomplished experimenter presented and demonstrated different types of pressure retouches achieved on siliceous rocks previously subjected to heat-treating²⁶. "Prehistorians-knappers" alone were enthralled by his work, and F. Bordes²⁷ brought the matter up again as early as 1969.

For heat treatment to be fully effective, the elevation in temperature and even more so the subsequent cooling must be very gradual; evidence for this has been claimed as much from contemporary examples - Khambhat, in the Gujarat (India)²⁸ - as from experimental work. The current principle, still obtaining in India and in Yemen for the treatment of chalcedonies, can readily be contemplated for earlier periods. Lumps of rough or already shaped stone are first buried in ash, under a heap of fuel (sawdust or charcoal, dung, etc.), which is left to smoulder for a number of hours; the stones are taken out only after complete cooling. The entire operation takes about 24 hours. In an archaeological context, it would of course be extremely difficult to identify hearths that were used for that purpose, since siliceous rocks can be efficiently heat-treated in multiple function hearths, such as cooking hearths. The only indisputable example of the use of structures for heating flint nodules comes from a Neolithic site of central India, in the Son valley²⁹. Heat treatment was carried out in each of the six horizons of the Khunjun site, the cores were pressure-flaked and the resulting bladelets were used as blanks for geometrical microliths.

In order to assess the expanse of this technique and the end(s) it was devised to meet, one must necessarily be capable of recognizing heat-treated products. There are two essential recognition criteria :

- heating changes the colour of some rocks, depending on the amount and the type of metallic oxides they contain (propensity towards rubefaction) (fig. 1 : 7);
- although the outside of the rock appears unchanged except for its colour, any breakage or removal taking place after heat treatment will expose a shiny, greasy surface, in stark contrast to its former dull aspect (fig. 68).

Minor accidents, such as the fine cracks often observed on chalcedonies and carnelians, also help to confirm the existence of deliberate heat-treating.

Although this technique, improving the nature of the stone, was not adopted and perpetuated by all groups after its invention, we have clear examples of its persistence. The heat treatment of carnelian, such as it is still practised in the traditional bead-making workshops of Khambhat in India, and in Yemen, testifies in all likelihood to the unbroken transmission of a prehistoric knowledge, since the technique has been applied to the same material for more than 7000 years in the Indo-Pakistani sub-continent. From the Neolithic onwards, it has in the same region also been applied to pressure-flaked flints and chalcedonies. In the case of carnelian, heating fulfills both an aesthetic and a technical purpose : not only does it improve the knapping characteristics of the stone, but it also alters the colour.

Clearly, it behoves us now to be systematic in our efforts to detect this technique in the industries where pressure is used (either for debitage or for retouching). This can be done by looking for the stigmas previously described, bearing in mind that experimentation and ethnographic observations can further our recognition of the phenomenon.

24 Flenniken, 1987.

25 Crabtree, Butler, 1964.

26 Smith, 1966a.

27 Bordes, 1969.

28 Posselth, 1981.

29 Clark and Khana, 1989.

Raw material procurement strategies

Knapped hard rocks have deliberately been presented from the point of view of the experimenter. It is however equally important to take account of all the observations concerning the provenance of raw materials, their availability, their abundance, their use, etc. Research into such matters may result not only in the analysis of economic systems, but also in the development of behavioural perspectives (ch. 6)³⁰. Indeed, the study of raw material distributions has in recent years proved a fruitful approach for tackling the question of territories, zones of influence, exchange and social interaction, etc.

The systematic sourcing of raw materials, through intensive surveys, is of course (even if this seems to go without saying) the first necessary step. This approach is not new ; it developed at the end of the XIXth century, but concerned mainly polished stone, petrographically different from knapped stone ; indeed with the advent of the Neolithic, the need for hard-wearing stone (generally of metamorphic origin), suitable for polishing and guaranteeing efficient cutting edges, brought about a quest for new materials set in new geological contexts. More recently, research has focused on other exotic raw materials, such as obsidian and its distribution (see for instance the many articles concerning Mesoamerica, Greece, circum-Mediterranean regions and the Near East, published over the last thirty years). This distinctive vitreous rock is easy to identify in any lithic assemblage, and can therefore unambiguously be termed exotic when the geological source is known to be far away. However, provenance studies should not be restricted to prestigious and exceptional materials alone, and the same emphasis must from now on be laid on all the mineral raw materials observed, even if they appear to be local. For it is important to decipher prehistoric people's attitude towards the materials they relied upon for their subsistence : stone is one of them, whatever its nature and its geological origin, and is furthermore unique in enduring nearly unaltered through time.

Moreover, unfounded assumptions about human psychological development have too often been made : the more man develops, the more he makes choices, selects and transports, and the less he allows himself to be dominated by environmental constraints. This assertion is probably true where general trends are concerned, but should be qualified according to each period, each region and each site, taking into consideration a growing number of parameters, which should throw light on raw material procurement strategies in particular.

The questions that must be asked before attempting any kind of inquiry into economic or social behaviour pertain to the natural environment and also to the requirements of the culture under study.

- The sourcing of raw materials and the appreciation of the manner in which past landscapes may have shaped the patterning of movements across the territory belong to the realm of the earth sciences. In this respect, answers to the following questions can help to dismiss some environmental constraints, and thereby bring choices to light.

- What is the geological context of occurrence? Is the raw material locally rare, or abundant?

- Is there only one sort of raw material, or are there several varieties?
- Is the raw material easy, or on the contrary difficult, to collect or extract?
- What is its quality, in what shapes and sizes does it occur?
- Could it be easily transported in its original shape?

- On the other hand, prehistoric man has tasks to accomplish, requirements to meet, different levels of technical abilities, and cultural traditions to respect, all of which can also be expressed in terms of preferences, or even constraints. The analysis of raw material procurement strategies, following from the study of lithic industries, must enable one to explain specifically cultural traits.

³⁰ There is a wealth of literature on this subject, so that we have chosen to mention only a few of the more recent publications, particularly well documented and referenced : Demars, 1982 and Geneste, 1991 for the Palaeolithic of the Aquitaine Basin ; Floss, 1994 for the Palaeolithic of the Rhineland ; Féblot-Augustins, 1997 for the Palaeolithic of western and central Europe as well as for earlier African industries ; for the question of flint-mining in the Neolithic, see Pelegrin and Richards (eds), 1995. The reader will find additional references in the different Flint Symposium papers published over the last ten years.

The deceptively simple problems mentioned above evoke a multiplicity of answers, some of them quite complex or interrelated, and give rise to a wide range of hypotheses. A cursory theoretical examination of three major issues will be made.

1. Provenance of raw material

A single region may yield both numerous and varied deposits (natural geological sections, outcrops, seams, colluvial deposits, alluvial cones, volcanic flows, fluvial terraces, moraines, marine deposits, etc.). One should also bear in mind that raw material accessibility may have varied through time, depending on the modifications of the geological landscape.

The accurate sourcing of raw materials makes it possible to appreciate the lithic procurement territory of each palaeoethnic group. The next step is the assessment of the methods of procurement, such as surface collection, outcrop quarrying, mining and so on.

2. Local availability of raw material

The presence or absence of workable hard rocks close to prehistoric sites is in itself a highly informative element, of great complexity.

The absence of any such rocks is rare, but their presence (provided they were accessible to prehistoric man) gives rise to many interpretations, which necessarily involve the dimensions, and sometimes the morphology, of the tools produced.

However, the most common alternative is the following.

- Hard rocks available in a form permitting the production of any desired blank, for instance blades, bladelets, large pieces, etc. As a corollary, does the site correspond to an occupation directly connected with the richness of the outcrop? If the site proves to be only a workshop the answer will be straightforward, but rather less so if the site includes living areas as well as working areas.

- Rocks available in a form suitable for specific tool morphologies, or nature of raw material adequate only for the manufacture of a limited range of tools. Thus, it is not infrequent that, in the same region, different raw material sources should be exploited by successive groups. For instance, in the Ténéré, at the Adrar Bous (Niger), cultures far apart in time occupied the same geographic location, but the Aterians used the local dark-gray microgranular rock to a far greater extent than the Neolithic inhabitants, who sought the well known “green stone” (dacite) outcrops, although they occurred dozens of miles away from most Neolithic living sites. A technical explanation is a possibility, since the green stone used by the Neolithics for the manufacture of their projectile points was suitable for bifacial retouching.

In a general way, differences in raw material use can only be ascribed to tradition if all other natural constraints have been taken account of. Other explanations involving, for instance, changing landscapes or the deterioration of the locally available rocks must not be dismissed.

3. Transport to the campsite

Another line of research has long been foreseen, but has only recently developed. This deals with the transport of raw materials to the campsite. As a first step, the constraints imposed by the sources of supply themselves should be assessed, in terms of accessibility, ease of extraction and transport. When faced with flake-cores, first consider whether the raw material in its natural form could be transported or not, before assuming a cultural motivation.

The following questions should then be asked. Was the raw material transported as unworked or initially roughed out blocks? Were the preforms and/or cores prepared at the source itself? Were the tools produced at the site or were they fashioned elsewhere and then subsequently transported as end-products?

Partial answers can be given to these questions by examining the artefacts with an eye for technology: by assessing, for instance, the proportions of cortical surfaces or the relative quantities of characteristic debitage and bifacial-knapping waste products, and above all by refitting (ch. 6).

	unmodified block	roughed out or preformed bifacial pieces	shaped out cores	roughing out and shaping out flakes	cores during or after débitage	characteristic flakes	unretouched knapping products	finished tools
A	●	●	●	●	●	●	●	●
B	○	●	●	●	●	●	●	●
C	○	●	○	○	●	●	●	●
D	○	○	○	○	○	○	●	●

● must be present ● may be present ○ left near "quarry site"

Fig. 3 — Raw material procurement strategies.

There are many ways in which the transport of raw materials to campsites can be theoretically contemplated, of which four are here considered (fig. 3) :

A - the material is brought to the campsite in its more or less original unworked condition (unmodified or tested by just one or two removals);

B - the material is brought to the campsite as prepared cores (unflaked) and/or roughouts of bifacial pieces (unfinished);

C - only unretouched débitage products and/or preforms of bifacial pieces are brought to the campsite;

D - only the tools (whether retouched or not) and the finished bifacial pieces are brought to the campsite.

Each of these possibilities or "strategies" can be detected when conditions allow, and can be plausibly suspected in almost all major archaeological excavations. It is simply a matter of noting the presence of well represented categories (fig. 3) of technically well defined pieces. The possible presence of other categories is not a contradictory factor, provided their occurrence is sporadic.

As the various technical stages in the *chaîne opératoire* are not always fully carried out, it is necessary to add the following points to the categories of objects in the table :

- rough blocks : including slightly modified;
- shaped out cores : including simply roughed out;
- roughing out and shaping out flakes : cortical flakes (quite numerous) and, where cores are concerned, crest-preparation flakes; first flakes can be quite rare finds;
- cores : at different stages of knapping;
- flakes, pieces characteristic of a débitage technique or method : crests, flakes resulting from the preparation and rejuvenation of pressure or striking platforms;
- finished tools : unretouched blanks in some cases (Levallois; blanks used without further modification), or retouched, or in the case of bifacial pieces, finished.

In each case, the complement can be assumed to have remained near the outcrops.

Chapter 2

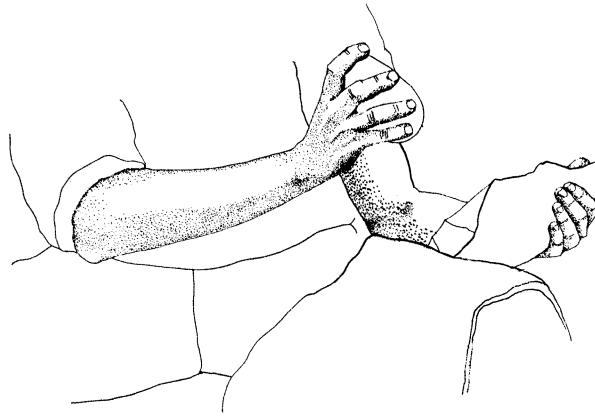

Knapping

Intentional knapping

The purpose of knapping is to make tools, in the broader sense of the term. Knapping will always leave similar scars on stone artefacts, irrespective of whether they are the work of the earliest hominids, or elaborate Bronze Age dagger blades from Denmark. Even if they are almost modern, like the many tinderboxes recently discovered on late Islamic sites, the scars will not differ. The technological interpretation of any worked stone artefact will therefore be specific to that artefact, and based on the precise observation and recognition of those scars. A stone artefact can only be defined as such by removal scars, both positive and negative. Resulting from either pressure or percussion, such scars obey physical laws and are identical whether knapping is intentional or not.

The diagnosis of intentional knapping is best vindicated when the artefacts are discovered in a well defined archaeological context. In the case of chance discoveries or surveys, the main criteria for recognizing intentional knapping is the organization of removals. Caution is required when flakes or even “pebble-tools” are found on a beach, for they may well result from natural phenomena; to the contrary, the discovery of a single handaxe or a single Levallois core can prove intentional knapping : the organization of removals follows so specific a sequence that the possibility of chance “knapping” due to random impacts can be dismissed. The number of pieces found and their geological position provide additional information concerning the context and further help to establish the possible presence of a site. However, one must bear in mind that it is not always easy to distinguish intentional from unintentional knapping, and the question often arises as to whether the modifications reflect intent or accident.

Knapping, shaping, flaking, retouching

Whichever way the stone-knapper goes about his work, he must use a set of tools, and these are presented in the appended lexicon (fig. 72 and fig. 73).

The term “knapping” has a general meaning, and applies to any type of action aiming at intentionally fracturing raw material. Knapping encompasses shaping, retouching and debitage (or flaking), which are each used in a more restrictive sense. These terms describe precise actions, and are dealt with in separate chapters. The word knapping is used when a more accurate one cannot be applied. This happens when the use and purpose of a knapped artefact cannot be clearly defined : for instance, is a chopper a core, an actual tool, or both ?

Knapping methods and techniques

The importance of distinguishing between these two terms was pointed out as early as 1965 during an international symposium³¹. By definition, knapping methods and techniques concern shaping, flaking and retouching.

Method refers to any carefully thought out sequence of interrelated actions, each of which is carried out according to one or more techniques. More often than not, the term method implies an elaborate conceptual scheme leading to the manufacture of predetermined products, whether by shaping or by flaking. Clearly, what must be identified is predetermination.

The main methods currently acknowledged are defined in chapters 3, 4 and 5.

Physical actions - a deft flip of the hand, the use of a hard or soft hammer, the interposition of a punch - are all examples of *techniques*. Thanks to major breakthroughs in experimentation, knapping techniques are now well identified. The criteria used derive from observations made on archeological assemblages, which are then substantiated by experimentation.

Special retouching techniques are treated in chapter 5.

Technical procedures are short systematic sequences of actions involved in any kind of preparation, such as : the abrasion of an overhang, the preparation of an edge prior to removal by a burin blow, the faceting of a striking or pressure platform, the preparation of a spur.

The main techniques

1. Percussion

Application of force to fracture raw materials.

Direct percussion

- Direct percussion with a stone hammer (hard or soft stone) (fig. 4) and, theoretically, its symmetrical opposite, percussion of an artefact on an anvil, are the main expressions of this technique. Various knapping techniques were invented through the ages, but the first undoubtedly was direct percussion with a hard hammerstone. For hundreds of thousands of years, it was the only technique applied, and its use endured throughout the history of stone-knapping. It can therefore never be used as a chronological argument.

Direct percussion with a soft hammerstone is suitable for the shaping of bifacial preforms and for the removal of moderately regular blades³². The materials chosen for this type of hammer include soft sandstones or cornstones, which tend to crumble on impact. Comparable results

³¹ We draw attention to the unwarranted use of the term “technological” where “technique” or “method” are more appropriate. A symposium organized by the Wenner-Gren foundation was held at Burg Wartenstein (Austria), during which several prehistorians discussed those problems of terminology (e.g. Balout, 1967 and Tixier, 1967).

³² Crabtree, 1972; Madsen, 1983; Pelegrin, 1991a.

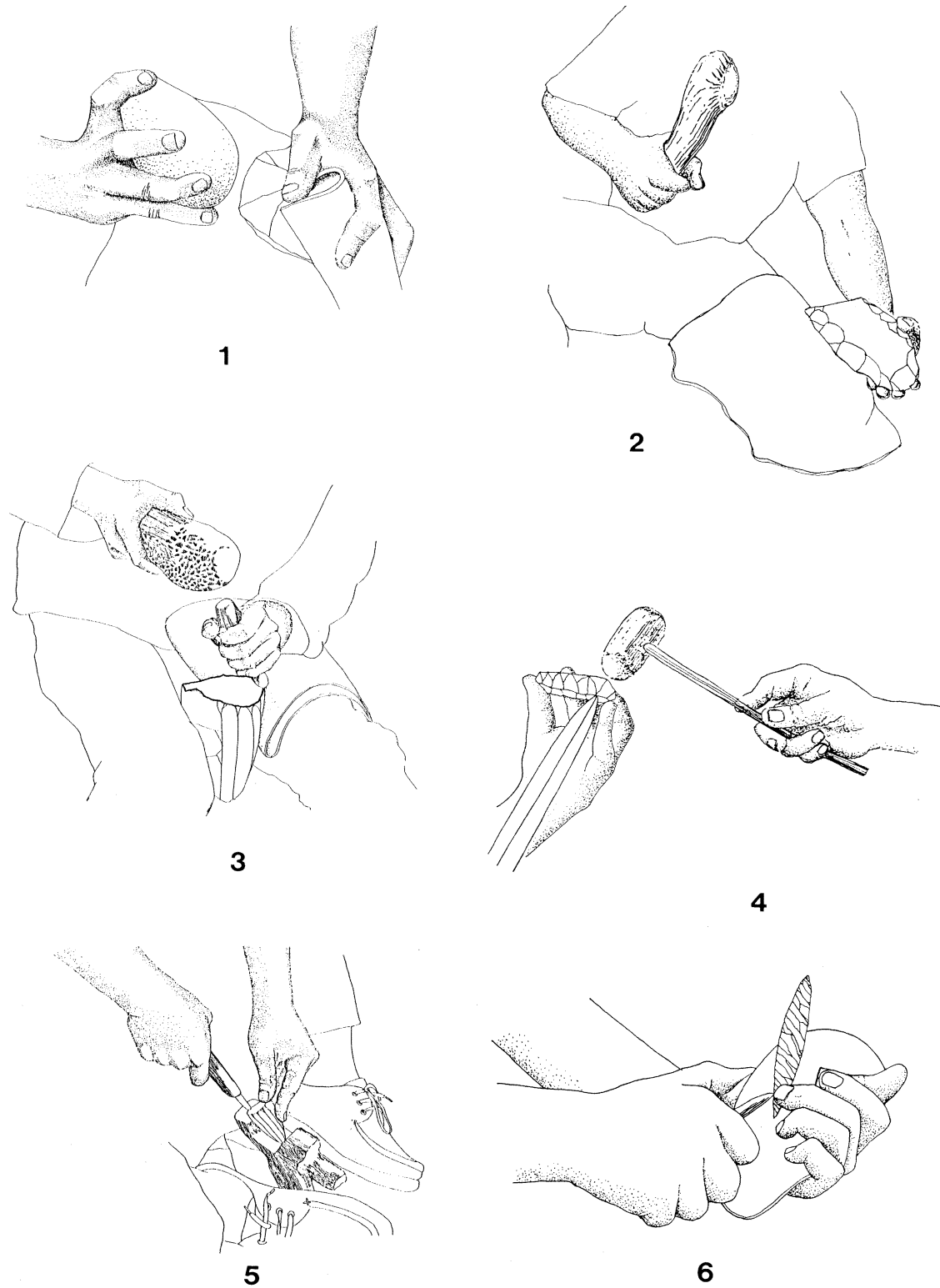

Fig. 4 — Knapping techniques. 1 : direct percussion using a stone hammer. 2 : direct percussion using an antler billet. 3 : indirect percussion (antler punch, wooden billet). 4 : indirect percussion by counter-blow. 5 : pressure with a short pelvic crutch. 6 : pressure in the hand (parallel retouches).

could not be reached with such other currently used rocks as quartzites, basalts, flints, etc., which are harder and more resistant.

- Direct percussion with a soft hammer (wood, antler, bone, ivory, etc.) occurs later in time (fig. 4 : 2). Evidence for this technique dates back to 700 000 years in Africa, but it probably appeared even earlier.

Indirect percussion

- Indirect percussion, in the accepted meaning of the word, involves the application of an intermediary tool, called punch, which can be of wood, antler, bone or metal (fig. 4 : 3). There is no indisputable evidence for this technique before the Mesolithic.

- Indirect percussion by counter-blow (fig. 4 : 4) is used today in Khambhat (Gujarat, India)³³ to make carnelian and agate beads and trinkets. The piece to be knapped is held in the hand, touching the end of a pointed iron rod stuck in the ground; the opposite side of the stone is then struck with a buffalo-horn-topped hammer; the flake is removed by the counter-blow of the pointed iron rod. It is a remarkably effective technique, and could have been invented in prehistoric times, or at least when bronze appeared.

2. Pressure

Application of pressure to fracture raw materials (fig. 4 : 5 and 6).

- Pressure is applied with the narrow end of a tool made of wood, antler, bone or metal. This debitage and retouching technique was invented in the Upper Palaeolithic. There are many different ways in which pressure can be applied (chap. 4, p. 76; fig. 30).

- Pressure with a lever

Considerable pressure (300 kg) can be exerted when a lever is used. This technique has only recently been experimented³⁴, and is suggested to have been used for the production of the outsize (up to 41 cm) Varna type of blades³⁵. It appears quite late in time, in the Chalcolithic and the Bronze Age, and is possibly connected with the use of copper.

Knapping products

The expression “knapping products” has a general meaning, which does not prejudge their possible final use. Knapping products are thus, in a broad sense, flakes (for the moment there is no need to be more specific) produced by any knapping operation.

Once knapping is shown to involve the production of blanks, these are known as debitage products. If and when a knapping product can be situated in its *chaîne opératoire*, it should be specified whether it is : a flake (*lato sensu*) resulting from the shaping out of a core; a flake resulting from the shaping of a handaxe; or a retouch flake, etc.

It is only after having studied the tools and the production of blanks that one may apply the more restrictive term “knapping waste products” to the residue of material that is obviously not predetermined, not retouched, and not conceived as tool blanks (even though any ordinary flake is always a potential blank).

33 Possehl, 1981 ; Roux, Pelegrin, 1989.

34 Pelegrin, 1988 : 48 ; Volkof, Guirria, 1991.

35 See Pelegrin's diagnosis in : Manolakakis, 1994.

1. Describing a flake

Removals from any lump of raw material produce flakes that share a number of characteristics, determined by the propagation of fracture waves in hard rocks. The following descriptions concern only such rocks as show conchoidal fractures, since they are chiefly the ones that were knapped throughout prehistory.

Whichever technique was applied to remove the flake, the identification of the latter as such is contingent upon the reading of fracture scars (fig. 5) :

- on the lower (ventral) face or flaking face, or more accurately fracture face (the opposite face being called the upper (dorsal) face) : percussion or pressure ripples, bulb, hackles, etc. ;
- on the butt (*i.e.* the part removed from the striking or pressure platform) : traces of preparation, impact point, etc.

It is relative to these two main elements that an unretouched flake is conventionally oriented, butt downwards. Butt and bulb can however be missing, in which case the flake can only be oriented if the other fracture scars are visible on the lower face : percussion or pressure

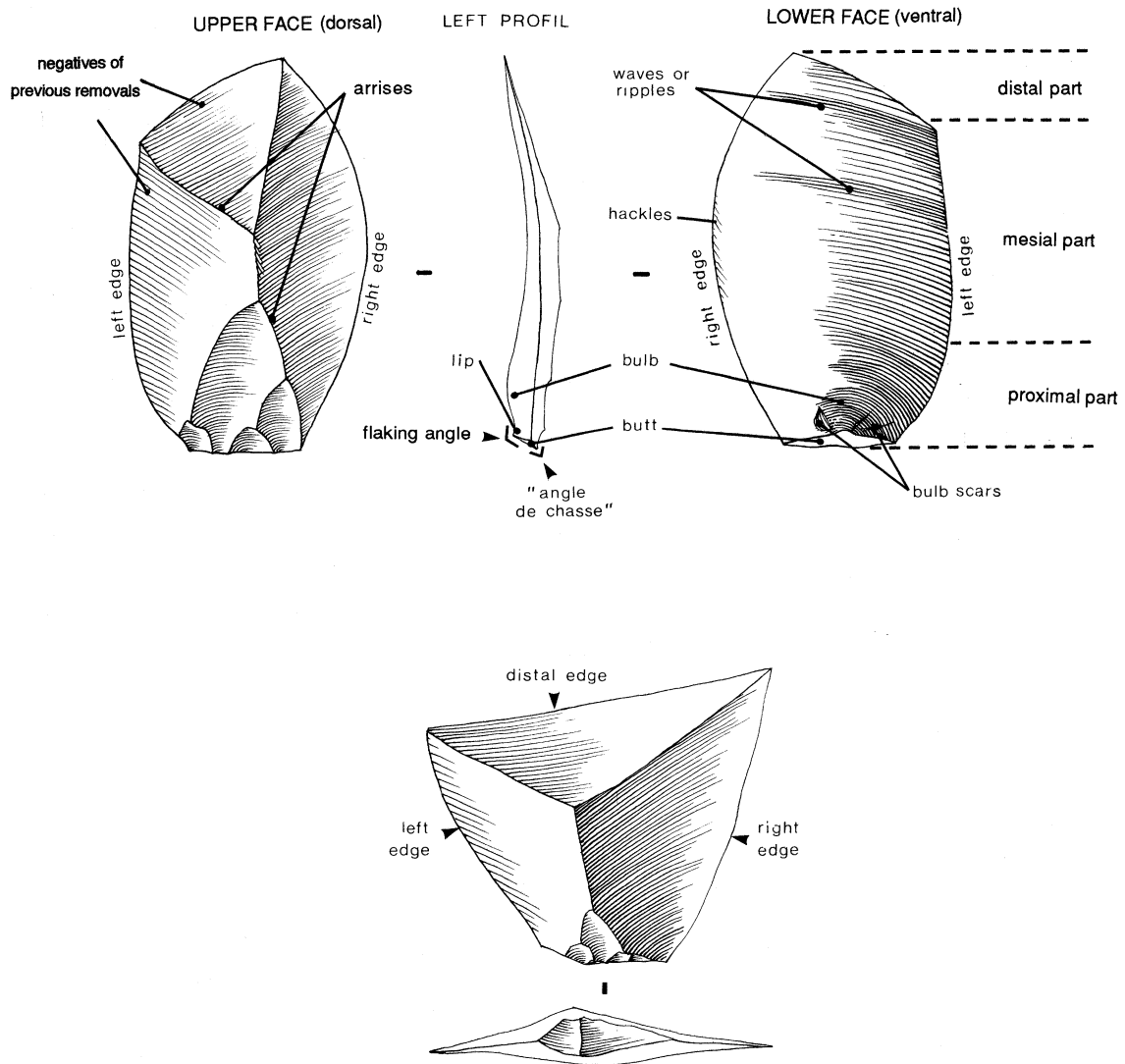

Fig. 5 — Main descriptive terms for flakes.

ripples, hackles (see p. 142). Paradoxically, while a flake is identified as such by its lower face, the left and right edges are designated in terms of the upper face following a conventional orientation, proximal part downwards (fig. 5).

Blades and bladelets are only morphologically different from flakes, and for them to be counted as such they must be at least twice as long as they are wide.

2. Characteristic flakes

Characteristic flakes are flakes that can without any ambiguity be mentally situated in the *chaîne opératoire* (fig. 8, 9 and 10), thanks to their distinctive features. They can result from shaping (bifacial-knapping flakes), debitage (crests, core-rejuvenation flakes) or retouching (Clactonian notch flake). The initial flake is universal : all knapping operations must yield a first flake, which is also characteristic.

3. Knapping waste products

This category concerns all the flakes or flake fragments that do not seem to have any possible use and/or cannot be situated in the *chaîne opératoire*.

- Characteristic waste products : although small, they belong to the category of characteristic flakes. Their presence can be indicative of specific knapping activities. A retouch flake from a small bifacial projectile point is a characteristic waste product.

- Debris : applies to any shapeless fragment, when the means by which it was fractured cannot be identified. A distinction must further be drawn between a debris and a broken fragment : while in the latter case the original object can be reconstituted, in the former it cannot.

4. Knapping accidents

A knapping accident, which may occur during flaking, shaping or retouching, is an unforeseen and unintentional incident generating products with a specific morphology³⁶. Archaeologically observed and experimentally produced knapping accidents are identical, thus strengthening the credibility of the analogy-based experimental approach.

They come as a certain number of “types”, and are due either to flaws in the raw material (joints, vesicles, saccharoid nodules, etc.) or to some mismanagement on the knapper’s part.

Knapping accidents have varying repercussions on the continuation of the knapping sequence to which they belong. They can be irreversible (fracture of a large leaf-shaped bifacial piece, plunging Levallois point, etc.), put right (hinged blade removed from a core with two striking platforms : in that case, a single removal struck off from the opposite platform is sufficient for debitage to proceed unimpaired), or of no consequence (bulb scars, fracture of a burin spall when the latter is a waste product, etc.).

Although unintentionally obtained, the products resulting from knapping accidents can also be used as blanks.

4.1. Breaks

Accidental snapping of a flake (*lato sensu*) upon removal, or of any artefact in the process of being knapped. The occurrence of breaks is irrespective of the technique employed (percussion, pressure, etc.), and the main types are listed hereafter.

- Clean breaks, whose surface is perpendicular to the debitage axis and the lower face (fig. 6).

- “Siret” accidental break : refers to the snapping in two of a flake along the debitage axis. Such accidents were long mistaken for burins; they leave but a partial arris on the core (when it is at all visible), on the distal part of the removal negative (fig. 80).

³⁶ Roche, Tixier, 1982.

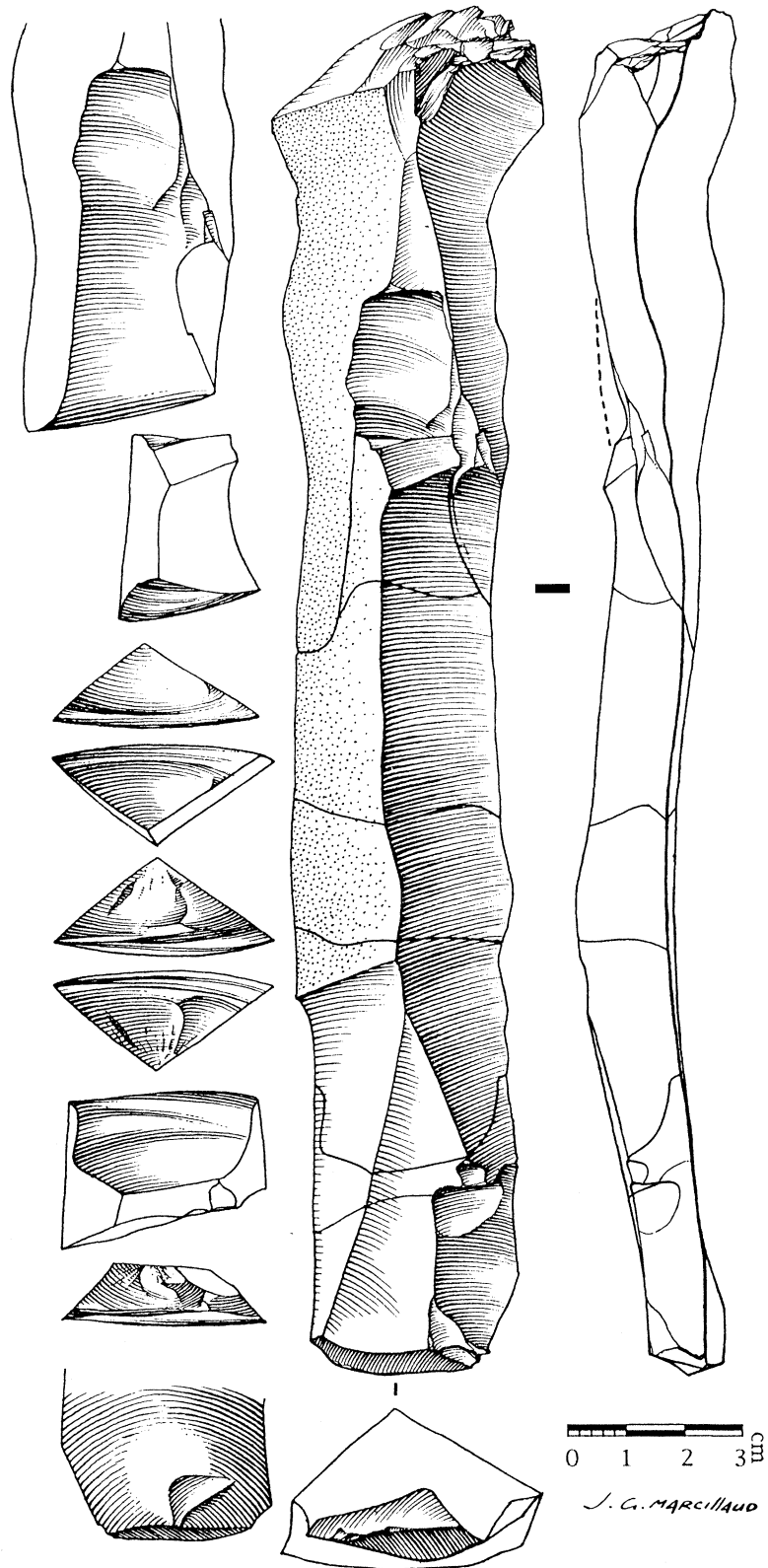

Fig. 6 — Large blade with multiple breaks (clean breaks, *languette*, etc.). Experimental debitage, direct percussion using a wooden billet (J.T.), Grand-Pressigny flint, Indre-et-Loire. The fragment outlined by a dashed line was not retrieved (Roche, Tixier, 1982 : fig. 1).

- *Langnette*³⁷ breaks occurring on the lower or upper face; they can be simple or double, in which latter case they sometimes generate characteristic waste products (fig. 7 : 2, 3 and 4).

- *Nacelle* breaks, initiated by bulb scars³⁸, which arch suddenly towards the upper face, removing part of the two edges, and then intersect quite as suddenly the lower face. The small waste product corresponding to the *nacelle* has a very specific shape (fig. 7 : 5). Such accidents are more common when pressure rather than percussion is applied.

4.2. Plunging flakes

They result from a phenomenon causing the fracture plane, whose proximal part is normal, to plunge suddenly away from the exterior surface and remove a whole section of the blank, be it a core, a debitage product or a tool (fig. 7 : 5 and fig. 74).

4.3. Hinged flakes

Hinged flakes are the opposite of plunging flakes, although they probably share the same physical causes (variation in the propagation speed of the fracture front). A hinged flake is a removal whose fracture plane, normal in its proximal part, arches suddenly and intersects prematurely the upper face of the blank, resulting in a rounded distal end (hinge-fracture)³⁹ or an abrupt clean break (step-fracture). The blank is therefore shorter than what was expected (fig. 7 : 1 ; fig. 14 : 3).

Hinged pieces and their removal negatives are very characteristic. It is the most common accident that befalls beginners when they try their hand at knapping.

4.4. Miscellaneous

- Incipient fractures should be included in knapping accidents, as well as incipient bulbs and still adhering flakes or blades.
- Lipped flakes.

During the knapping of bifacial pieces or blades, and especially when direct percussion with a soft hammer is applied, the flake or the blade may happen to remove a larger amount of material than expected in the butt area. The result is a proximal part showing a very broad butt, an extremely diffuse bulb with a concave profile and a postbulbar constriction. The removal negative, bearing some similarity to a Clactonian notch, disfigures the edge of the bifacial piece or the striking platform of the core. The specific nature of this accident lies in the fact that the fracture initiates far behind the impact point of the hammer. If they are not closely examined, such flakes can well be mistaken for plunging flakes. The occurrence of such an accident is irrespective of the raw material used.

- “Parasitical” flakes

Such flakes are either complementary (in the case of bulb scars, for instance, fig. 5) or supplementary (“splinter” chipped off from the overhang of the striking platform, upon removal of a flake by percussion; the waste product is elongated, with a triangular cross-section, and shows neither butt nor bulb).

- “Spontaneous” removals

These occur within a fraction of a second after the removal of a flake, when the latter cannot fall free because the core rests on the knapper’s hand, foot or thigh, and are not easy to distinguish from the intentional removals resulting from retouching. They generally concern the distal end of the blank (short removals), but can also produce notches (or even denticulates) on the lateral edges⁴⁰.

It is absolutely necessary to have a comprehensive knowledge of knapping accidents in order to :

37 Bordes, 1970.

38 Therefore, “dorsal *nacelles*” cannot exist.

39 Crabtree, 1972 : 25.

40 Newcomer, 1976.

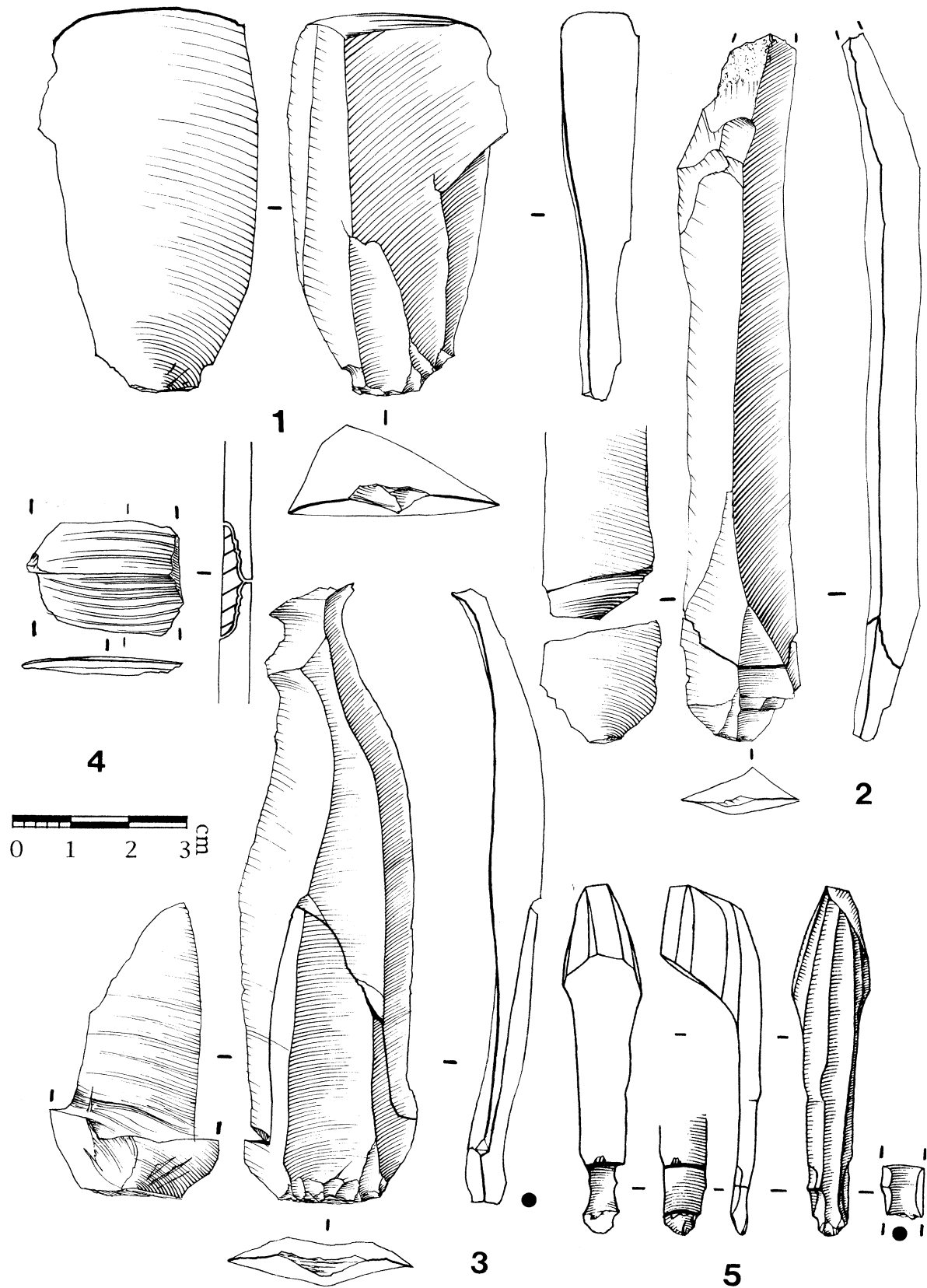

Fig. 7 — Experimental knapping accidents. 1 : hinged flake (aborted blade), direct percussion using an antler billet, Bergeracois flint, Dordogne. 2 : blade with a simple lower face *languette*, indirect percussion “under the foot”, Goussainville flint, Oise. 3 : blade with a long upper face *languette*, indirect percussion, Idaho obsidian, U.S.A. 4 : “parasitical” flake between two opposite *languettes*. 5 : plunging bladelet with a lower face *nacelle* break, pressure debitage using a pectoral crutch, obsidian (Roche, Tixier, 1982 : fig. 3, 1).

- distinguish intentional from unintentional knapping, which is crucial;
- better understand technical physical actions and their chronology, as well as the operative schemes brought into play; a burin that has been disfigured by a plunging spall need not be entirely discarded : the distal end of the negative of the spall can be used as a surface on which another burin blow will be applied to produce, for instance, a new dihedral burin;
- better appreciate techniques through a comparison with modern experiments;
- assess the knappers' degree of competence;
- apprehend a tradition with greater confidence when accidents are linked to specific techniques.

The observation of knapping accidents by prehistoric people probably caused them to master the phenomenon, thus converting it into something intentional : anyone trying to make a backed edge on a blade will sooner or later break it, accidentally producing a microburin or a "Krukowski" microburin. This technique was systematized long before the time of geometrical microliths, in the early Upper Palaeolithic of North Africa : more than 20000 years ago, it was applied in the Iberomaurusian to make La Mouillah points⁴¹.

Another example of the systematic use of accidents concerns the plunging Levallois flakes necessary to the manufacture of Tabelbala type cleavers⁴² : this ultimate technical action in the knapping sequence is a particularly original feature in the production of those Acheulean artefacts from the western Sahara and South Africa. Here, it would be disastrous not to achieve a plunging flake !

⁴¹ Tixier, 1963 : 106.

⁴² Tixier, 1956.

Three knapping sequences

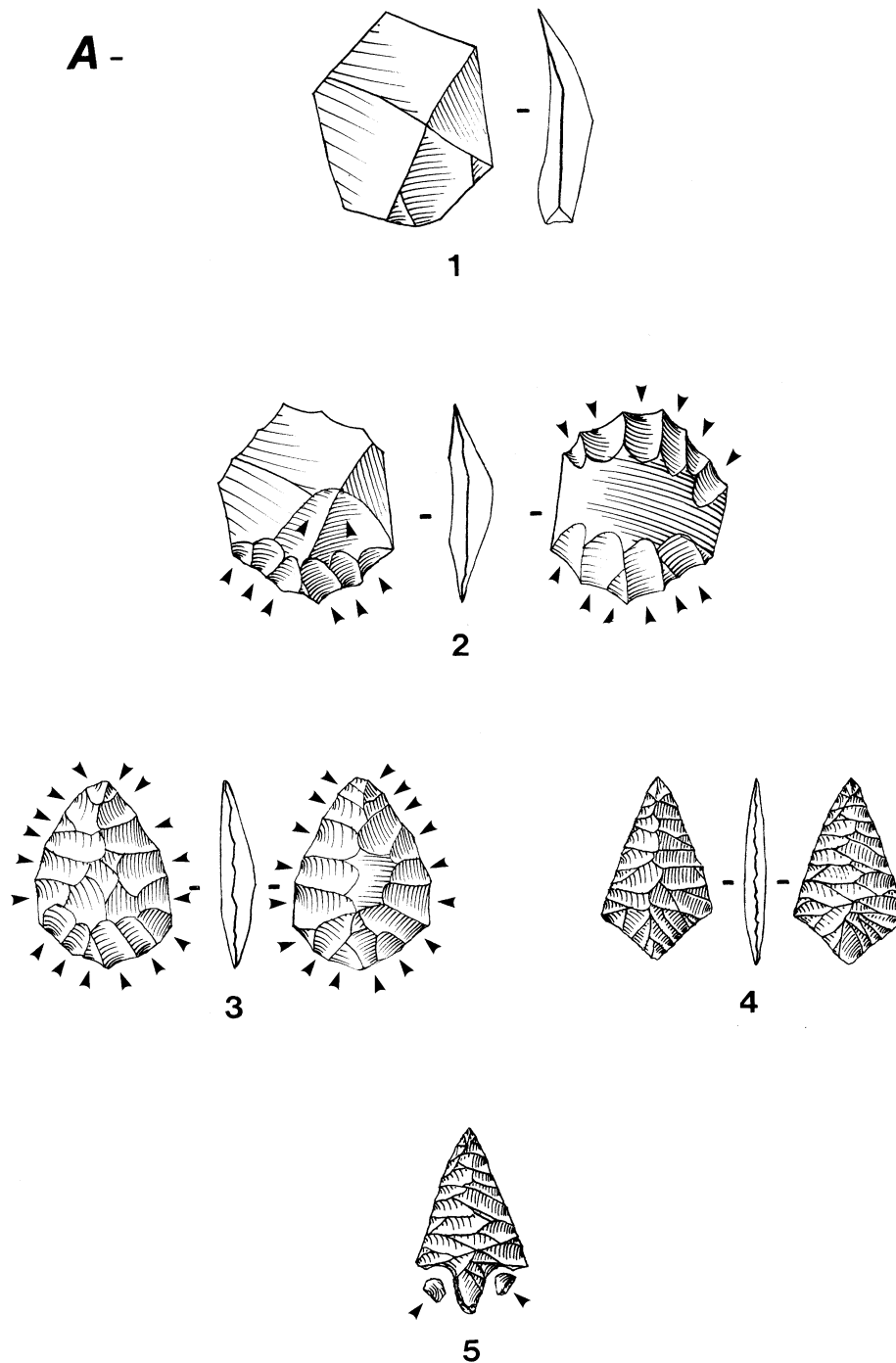

Fig. 8 — Bifacial shaping of an arrowhead with tang and wings, starting from a flake. 1 : unretouched flake. 2 : roughing out by percussion to thin the proximal end (bifacial removals) and reduce the curve of the distal end (inverse removals). 3 : achieving the preform by percussion. 4 : finishing by pressure. 5 : carving out the tang.

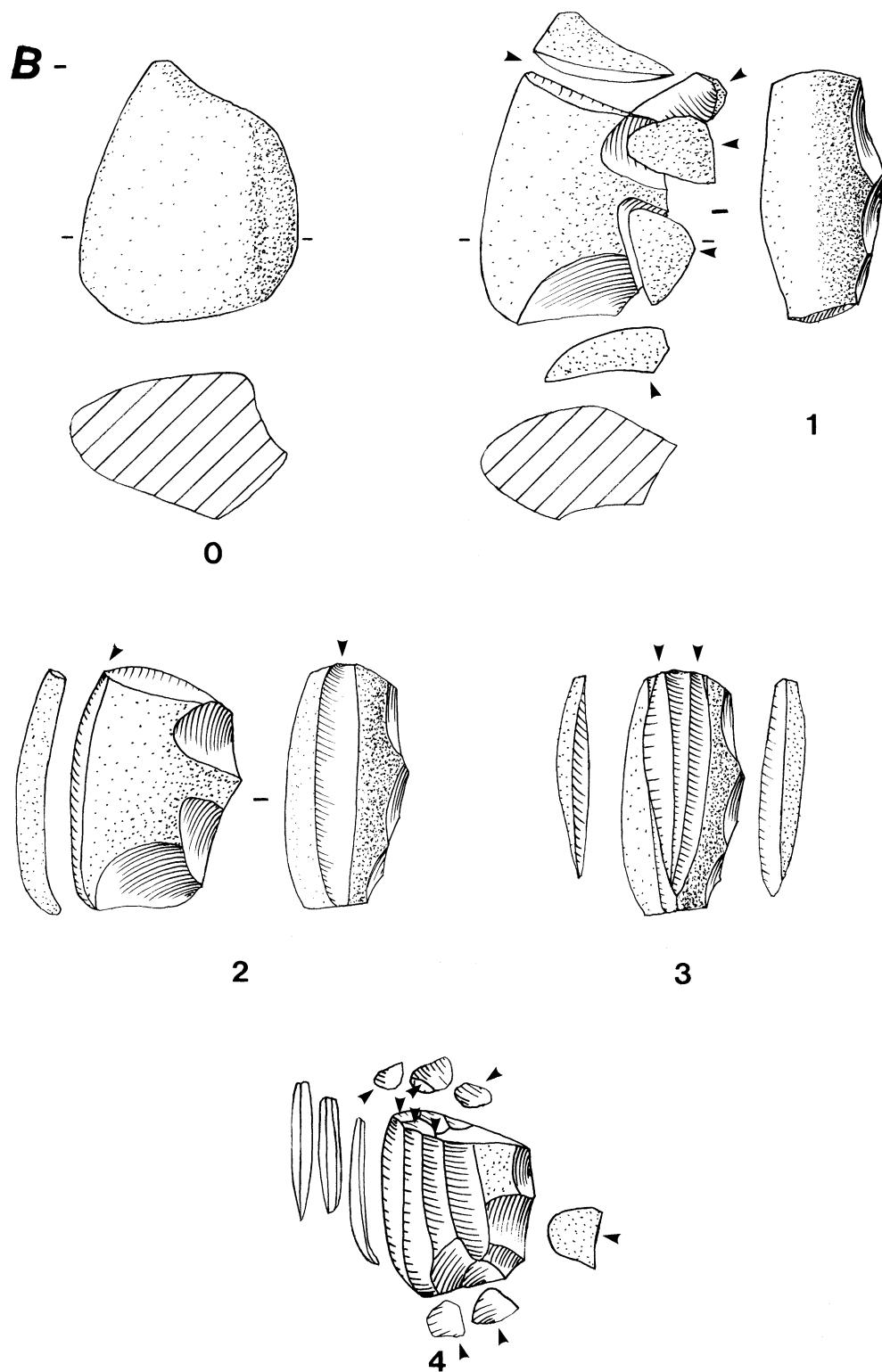

Fig. 9 — Blade debitage carried out on a core with a single striking platform. 0 : unmodified block. 1 : summary shaping out, creation of a striking platform. 2 : removal of a first blade, entirely cortical. 3, 4 : successive removals of blades of *plein débitage*, with rejuvenation of the striking platform.

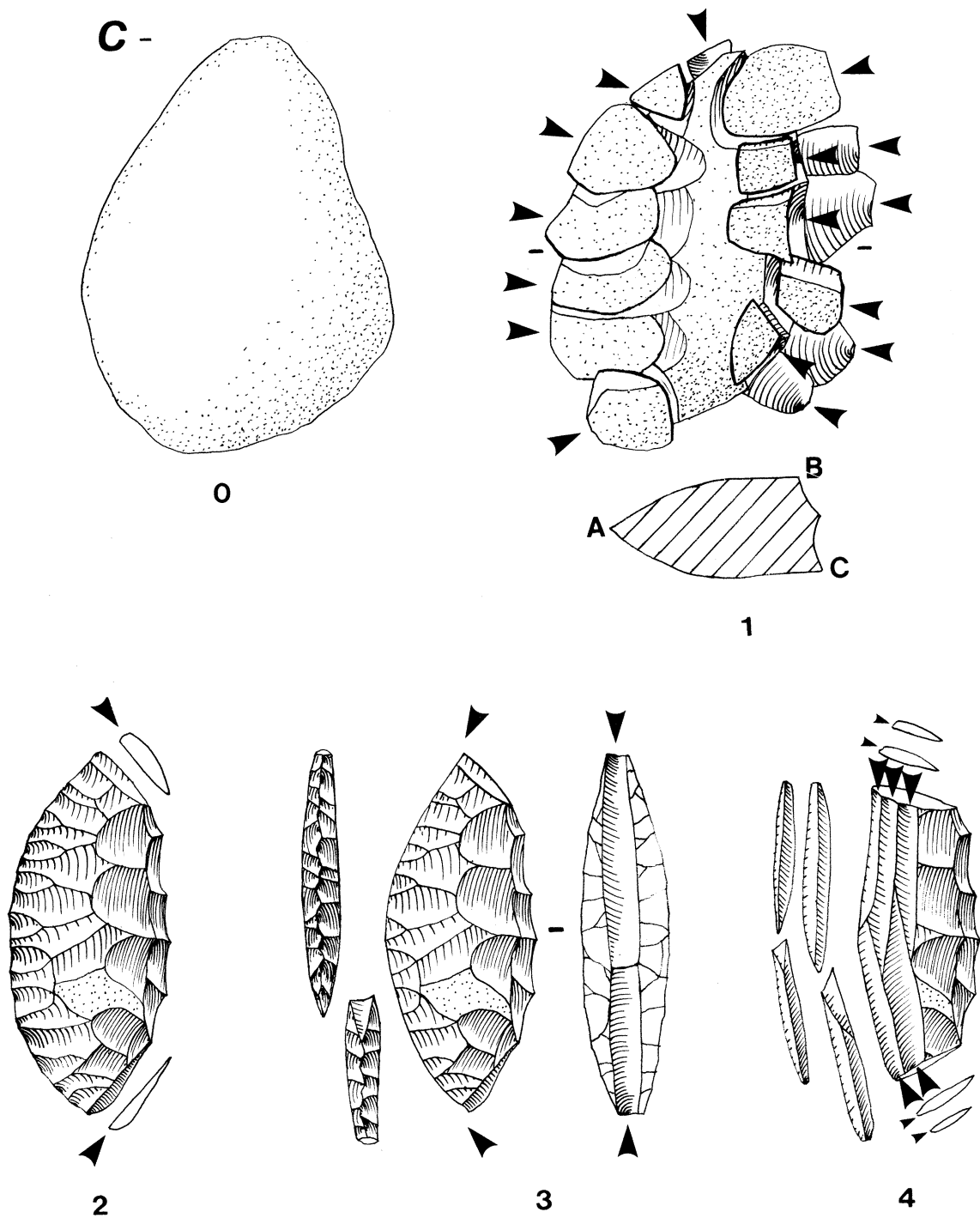
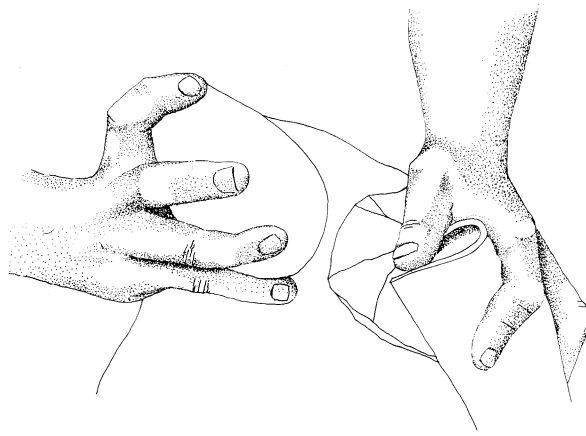

Fig. 10 — Blade debitage carried out on a core with two opposite striking platforms. 0 : unmodified block. 1 : shaping out the core by means of an initial frontal crest (A) and two postero-lateral crests (B and C). 2 : creation of two opposite striking platforms. 3 : removal of two opposite crested blades. 4 : blade debitage with platform rejuvenation (*plein débitage*).

Chapter 3



Shaping

We use the term shaping to indicate a sequence of knapping operations carried out for the purpose of manufacturing a *single* artefact by sculpting the raw material in accordance with the desired form. This particular knapping mode, which can be fitted into any of the phases of a *chaîne opératoire*, aims at creating a specific morphology, whether it be an arrowhead (whose function can be presumed), a handaxe (the use of which remains unknown), or the preform of a stone axe that will subsequently be polished.

Although shaping applies mainly to bifacial pieces, it can concern other artefacts of varied morphology, such as polyhedrons and spheroids, trihedrons, chisels, stone axes with square cross-sections, etc. Shaping also applies to the manufacture of preforms. However, when an operation akin to shaping is shown to belong really to a *chaîne opératoire* concerned with debitage, one speaks of a core being shaped out because the underlying concept is different. A case in point is the Japanese Yubetsu method for the production of bladelets (p. 79).

With shaping, it is not always possible to say what was actually intended : the fashioning of a single tool or the production of blanks. Most *chaînes opératoires* concerned with shaping produce quite a number of flakes that can be used as blanks for flake tools. It is also often impossible to ascribe utilitarian properties to the artefacts resulting from shaping.

Shaping is a mode of knapping that is very widespread, in both time and space, and has been applied to almost all the types of raw material suitable for knapping, from coarse-grained quartzite to obsidian.

Finally, shaping encompasses a certain number of methods, each of which shows many variations. The following developments concern only some of the major methods : bifacial shaping, polyhedral and spheroidal shaping, trihedral and quadrangular shaping. Preforms, by definition an intermediate stage in a *chaîne opératoire* and not associated with any particular morphology, are dealt with in a separate section, as well as cleavers, a very special type of tool.

Bifacial shaping

Bifacial shaping appeared in eastern Africa at the end of the Oldowan period, more than one and a half million years ago, and has virtually always been used ever since. The handaxe is an all-important feature of the Lower Palaeolithic. Although not omnipresent, it is - sometimes along with the cleaver - the best represented tool in Acheulean industries. It remains conspicuously present during the Middle Palaeolithic. In later periods, bifacial shaping appears or disappears depending on the culture. In the French Upper Palaeolithic, for instance, it reaches its apogee with the Solutrean, but is not taken up later by the Magdalenians. On the other hand, in other cultural contexts, such as Asia, bifacial shaping features in the technical background during the entire Upper Palaeolithic. As from the end of the Mesolithic and until metal appears, it becomes virtually universal owing to the development of projectile points.

1. Methods

Although the methods used for bifacial shaping vary considerably according to the different periods, the basic concept stays much the same. Differences appear only within the operative schemes, the techniques and the way in which they are applied. The bifacial concept is described here from a general point of view.

Whichever way the original blank was obtained (it can, for instance be a large flake struck off from a core), bifacial shaping can be divided into two phases, roughing out and finishing.

- Roughing out consists in the simultaneous fashioning of two more or less convex surfaces on either side of a *bifacial equilibrium plane*⁴³ (fig. 11 : A). This term is used in preference to plane of symmetry because the two surfaces - which define a contour, marked out by a ridge - are definitely not always symmetrical, and this applies in particular to handaxes.

- Finishing consists in giving the contour a regular shape, according to a second *bilateral equilibrium plane* (fig. 11 : B), perpendicular to the bifacial equilibrium plane. Finishing bears some similarity to retouching, especially where small pieces made from flakes are concerned. It is this step that gives the artefact its final morphology, by delineating the edges, carving out a tang, or arrowhead wings, etc.

Any blank can be shaped into a bifacial piece : a cobble, a block, a slab, a chunk of stone, and of course a flake (fig. 8). The closer the morphology of the blank is to the intended final shape, the less work is required to rough it out. In the case of a bifacial piece made from a thick block, it is necessary to do some preliminary flaking before roughing out can be undertaken : this entails flaking away the cortex and coming closer to the desired morphology. On the other hand, one or two generations of removals only are needed to shape a bifacial piece made from a flake. Some Acheuleans have systematically struck off large, short and wide slightly *déjeté* flakes, to use as blanks for their handaxes : in that case, shaping is incorporated into a longer *chaîne opératoire*, which includes an initial flaking sequence that shows predetermination in the obtaining of blanks⁴⁴.

2. Techniques

Prehistoric people applied the main stone-knapping techniques to bifacial flaking as they successively invented or adopted them : direct percussion with a hard or soft hammer, indirect percussion, pressure, pecking, and then polishing.

As early as the middle Pleistocene, different techniques were brought into play for the fashioning of a single bifacial artefact : direct percussion with a stone hammer to first remove the blank and then rough it out, direct percussion with a soft hammer to give the piece its final shape. These two operations generate characteristic flakes (fig. 14). The shift from one technique

43 Texier, 1989 ; Roche, Texier, 1991.

44 Texier, Roche, 1995b.

to another in the course of roughing out and finishing is not systematic, but it does occur quite frequently. Unquestionable evidence for this practice dates back to 700000 years in eastern Africa, and it probably existed even earlier. In some long *chaînes opératoires* including preforms and belonging to more recent periods, it is not uncommon to see three, or even four different techniques used for the manufacture of a single artefact (see below).

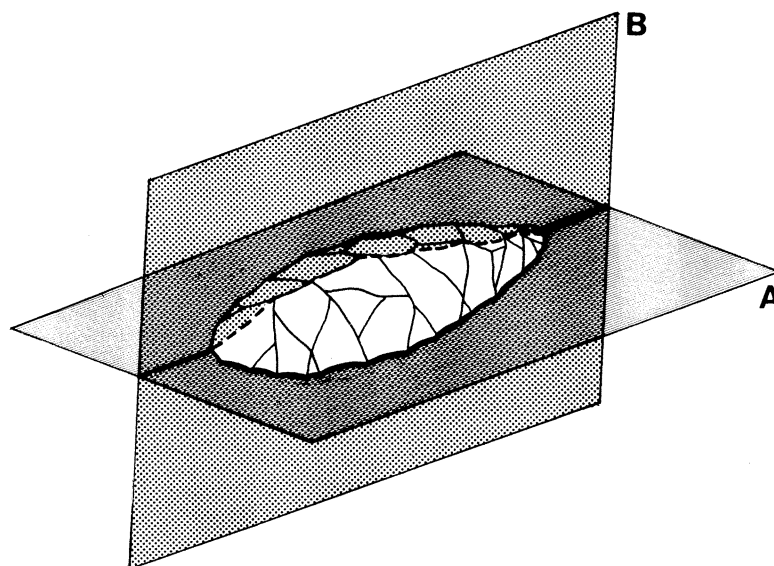

Fig. 11 — Bifacial (A) and bilateral (B) equilibrium planes of an handaxe.

3. Morphologies

The morphologies of bifacially shaped objects can be very variable (figs. 12, 13, 37). The above mentioned distribution of volume during roughing out can tend towards symmetry on either side of the bifacial equilibrium plane, or remain asymmetrical. Likewise, the frontal view can be perfectly symmetrical bilaterally, or show an intended (or fortuitous) asymmetry.

Some shapes remained morphotechnically stable over very long periods, like the Acheulean handaxe. Use-wear analysis is yet unable to identify the functional reasons for the success of the handaxe. However, it seems that its development was closely linked to the acquisition of the idea of symmetry (well mastered during the early Acheulean, one million years ago), even if far from always perfect, and also to the ability to flake large blanks.

Other bifacial morphologies, on the other hand, result from specific conceptions with a limited existence in both time and space, like the Middle and Upper Solutrean laurel-leaves, whose function, once again, can only be surmised. That of projectile points can be more readily appreciated: their morphology is extremely varied, each shape corresponding to ballistic and hafting requirements.

Of all the knapping modes, bifacial shaping is undoubtedly the one that most exquisitely combines efficiency with fancy and imaginative power, as well as with technical performance: witness the dacite disks from the Ténéré⁴⁵, for instance, the north-American Ohokam points⁴⁶, and of course the well known Maya *excéntricos*⁴⁷.

The variety of shapes resulting from bifacial shaping has given rise to a large number of classifications, most of which are morphological and of limited interest. It is essential that other

45 Joubert, Vaufrey, 1941-1946.

46 Crabtree, 1973.

47 *Boletín de Anthropología Americana*, 1982.

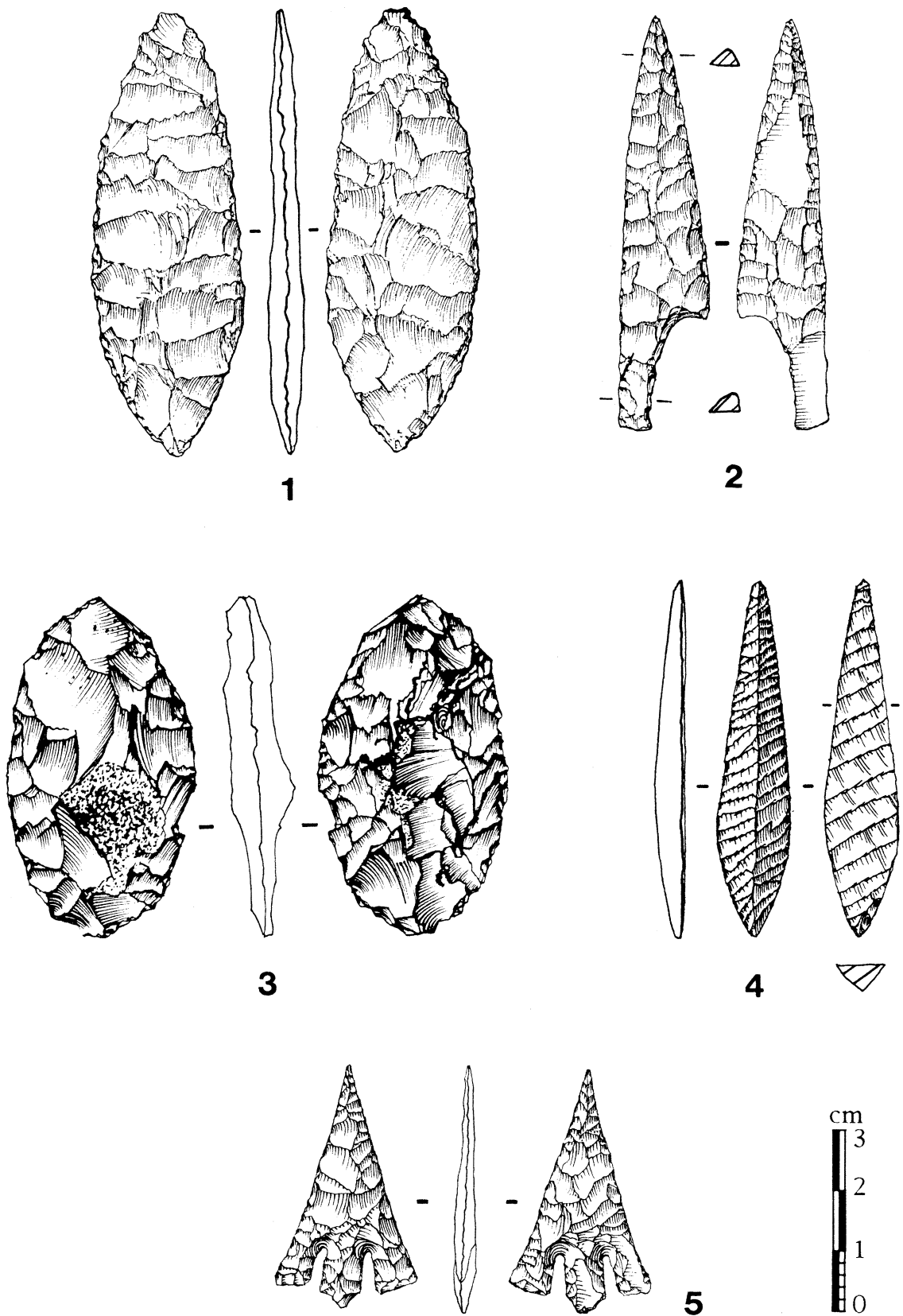

Fig. 12 — Various examples of bifacial shaping. 1 : “laurel-leaf”, Solutrean, Les Jeans-Blancs, Dordogne. 2 : shouldered point, Solutrean, Le Placard, Charente. 3 : bifacial foliate piece, Neolithic, Shagra, Qatar. 4 : bifacial piece, Neolithic, Al-Abr, Yemen. 5 : arrowhead with tang and square wings, Neolithic, Shagra, Qatar. 1 and 2 (Smith, 1966b : fig. 50, 1 and fig. 67, 6), 3 and 5 (Inizan, 1988 : fig. 49, 6 and fig. 51, 5).

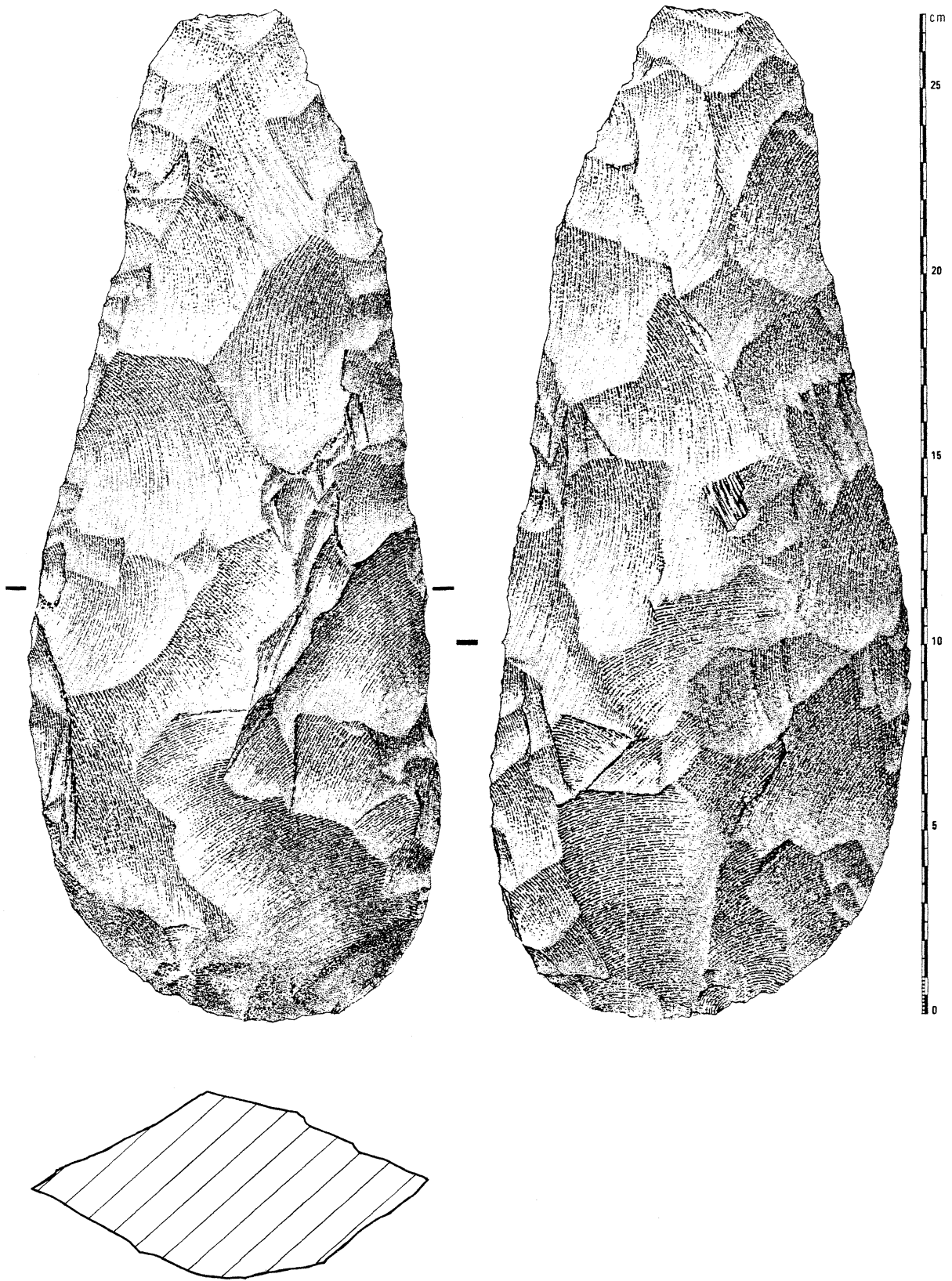

Fig. 13 — Example of bifacial shaping : Acheulean handaxe, phonolite, Isenya, Kenya.

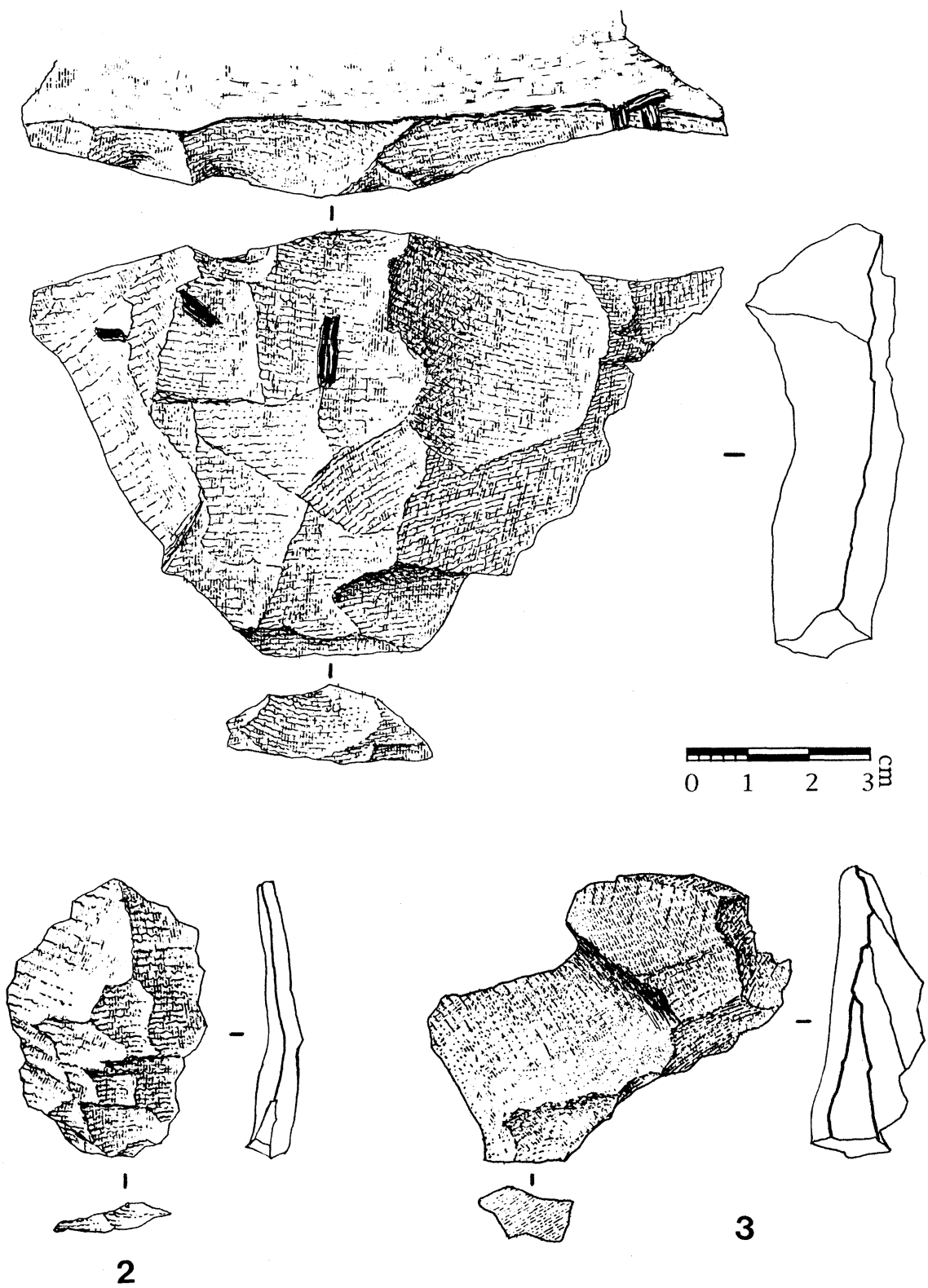

Fig. 14 — Bifacial-shaping flakes, phonolite, Isenya, Kenya. 1 : plunging flake. 2 : finishing flake, soft hammer. 3 : flake displaying a hinged removal negative.

aspects be from now on taken into consideration, namely technological data and the relationship that prevails within a single assemblage between flaking and shaping sequences. Only thus will we further our understanding of prehistoric people's management of their raw materials and gain greater insight into the conceptual and operative schemes brought into play.

Polyhedral and spheroidal shaping

Polyhedral shaping is not carried out in relation to secant planes, but in relation to a virtual point of balance around which the volume of the piece is more or less equally distributed⁴⁸ (fig. 15).

The method consists in striking off non-contiguous flakes from opposite directions, the intersection of the removals forming an angle of more than 90° (in theory the maximum value between the striking platform and the flaked surface). This ensures that the thickness of the artefact will be preserved and at the same time creates the ridges that are so typical of the true polyhedron (fig. 16 : 1). The wider the angles, the closer the polyhedral form comes to being a sphere.

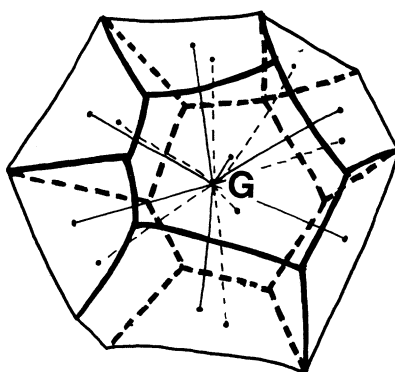

Fig. 15 — Point of balance or point of gravity (point G) in polyhedral and spheroidal shaping.

It is possible to obtain a spheroid (fig. 16 : 2) from a polyhedral form, in which case the ridges are partially crushed by pecking. However, spheroids can also be obtained through partial fashioning of naturally rounded forms.

The same methods are applied to bolas (fig. 16 : 3), but pecking concerns all the facets of the artefact in order to obtain a perfect sphere.

Thus, polyhedrons, spheroids and bolas can represent different segments of a single *chaîne opératoire*.

Technically, polyhedral and spheroidal shaping is carried out by direct percussion with a hard hammer. The transformation of a polyhedron into a spheroid, or even more so, that of a spheroid into a bola, is achieved through pecking, with a shift in techniques : first direct percussion and then pecking, both techniques involving the use of a stone hammer. In such cases, the spheroid can be considered as a preform (see below). Contrary to what has often been stated, a polyhedron is not the result of chance knapping or of the mismanagement of a flake-core; its manufacture is dependant upon a method requiring that shaping be well mastered, and this method is not easy to replicate experimentally. And while a hammerstone can become perfectly rounded through long and well controlled use, there can be no doubt about the intentional shaping of prehistoric (and historic) bolas.

48 Texier, Roche, 1995a.

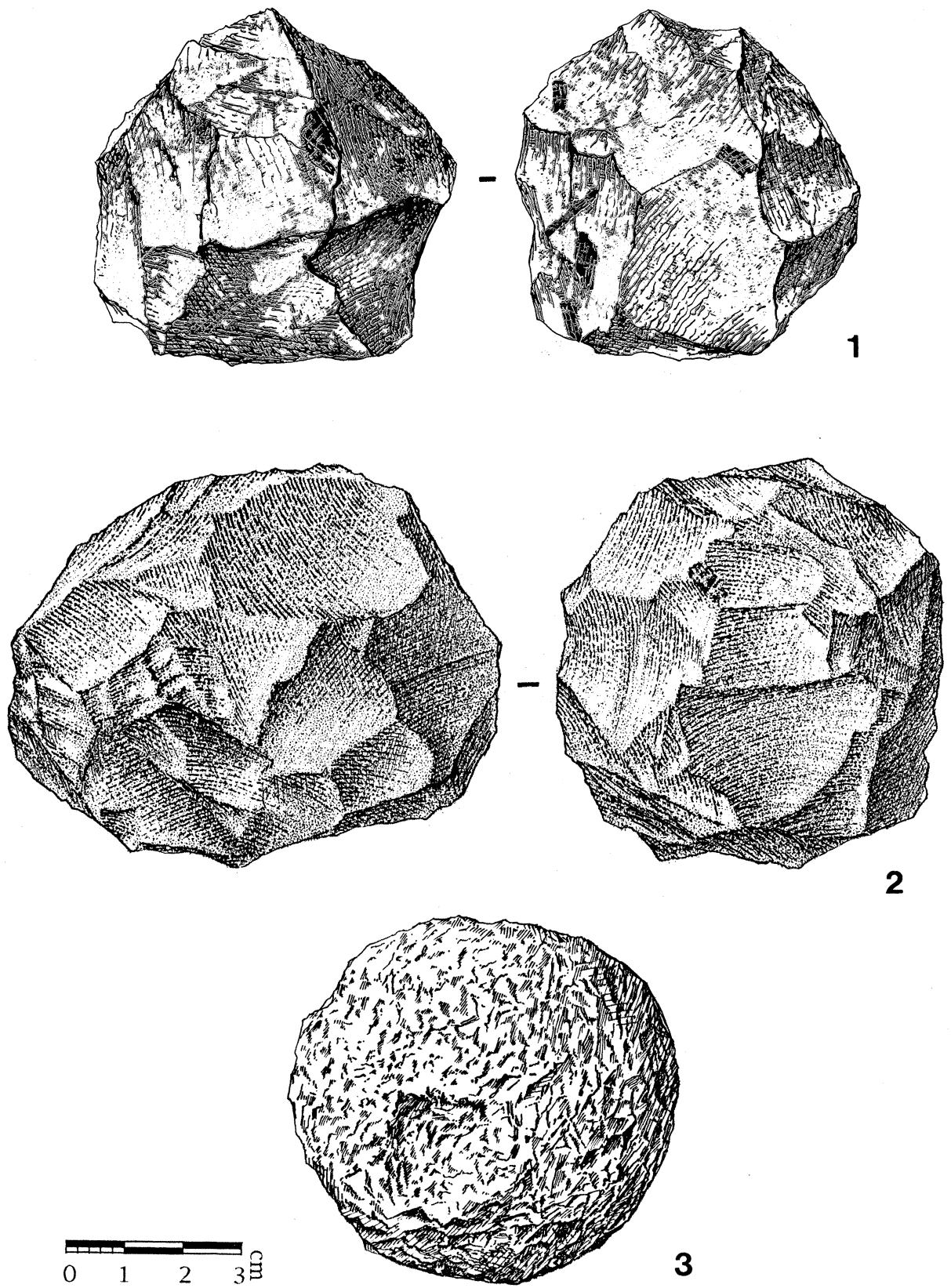

Fig. 16 — Polyhedral and spheroidal shaping. 1 : polyhedron (phonolite). 2 : spheroid (phonolite). 3 : bola (quartz), Acheulean, Isenya, Kenya.

Polyhedral and spheroidal shaping appears very early on, in the Oldowan period, and endures throughout prehistoric times. It is however far less common than bifacial shaping, its conceptual opposite.

Other shaping methods

Shaping can yield other products of varied morphology, triangular, square, rhomboidal, etc., in cross-section, which are dependant upon different methods for their manufacture. Two of these methods are described hereafter.

- Trihedral shaping

The terms trihedron, pick or trihedral pick designate artefacts that are both elongate and robust, with one or both tip ends rough-hewn to form a crude triangular point, or else a narrow chisel (fig. 17).

Picks can be made on any kind of blank. Actually, a large number of knapping schemes are available to shape the point, depending on whether one or possibly two surfaces (natural surface or fracture face) are preserved - they can then be used as striking platforms - or whether all three faces are knapped. The base need not be systematically modified⁴⁹.

The technique used is direct percussion with a hard hammer.

The trihedral pick, whose function eludes us, is not a very common artefact. It appears at the very beginning of the Acheulean, but develops mainly in the Sangoan (African Lower/Middle Palaeolithic transition); it is also documented in the Upper Palaeolithic - but in a “lighter” version - and can be found in some Mesolithic cultures.

- “Quadrangular” shaping

This method is not widespread. It is undoubtedly best exemplified by the preforms of the so-called “square cross-section” stone axes (the cross-section actually is rectangular) of the Danish Final Neolithic (fig. 18 : 1) (see following section), or by those of south-east Asian stone axes.

Quadrangular shaping is mainly connected with preforms, with the exception of the Danish Bronze dagger hafts, which are not further modified. The method requires to be very well mastered technically, in particular where large-sized pieces are concerned. A clumsy removal during the roughing out stage can - in a deferred but irretrievable way - jeopardize the ultimate shaping stages or the polishing stage.

Preforms

A preform is the result of the particularly careful preparation of a roughout, preliminary to the finishing phase during which one or more techniques are brought into play (fig. 47). Finishing scarcely modifies the shape of the preform, and the main finishing techniques used are percussion, pressure, polishing, and pecking. Heat-treating may occur at one point in the *chaîne opératoire*, and the way in which the techniques are ordered is eminently variable (for instance heat treatment followed by pressure, polishing followed by pressure, pecking followed by polishing, etc.).

Four examples of *chaînes opératoires* that include preforms are developed below : two archaeological examples, the comprehension of which has been largely dependant upon experimentation, and two ethnographical examples taken from very different contexts, a testimony of the enduring practice of stone-knapping and of its socio-economic and symbolic role.

49 Brézillon, 1968 ; Leroy-Prost, Dauvois, Leroy, 1981.

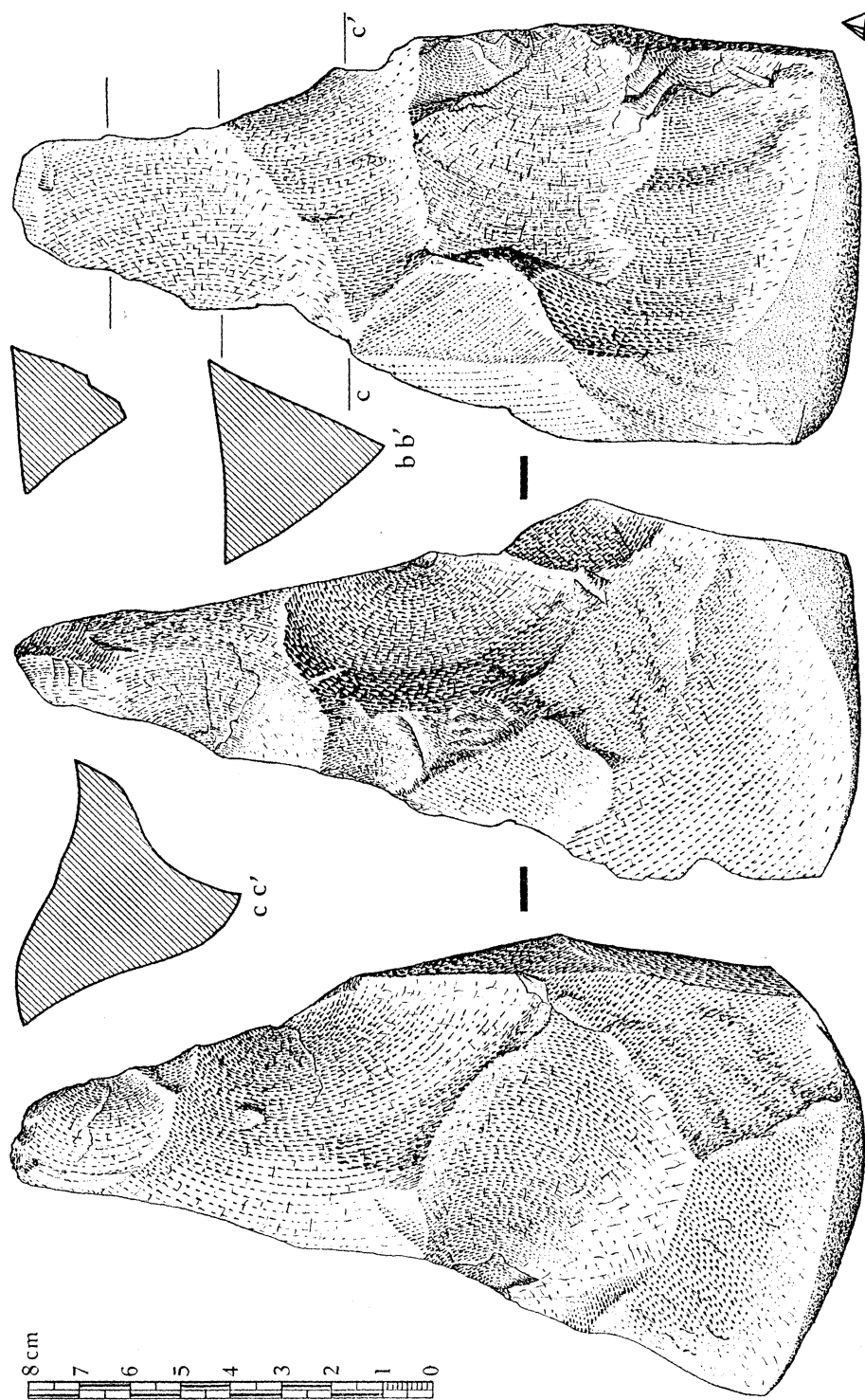

Fig. 17 — Trihedral shaping : trihedral pick (quartzite), Acheulean, Casablanca, Morocco (Dauvois, 1976 : fig. 17).

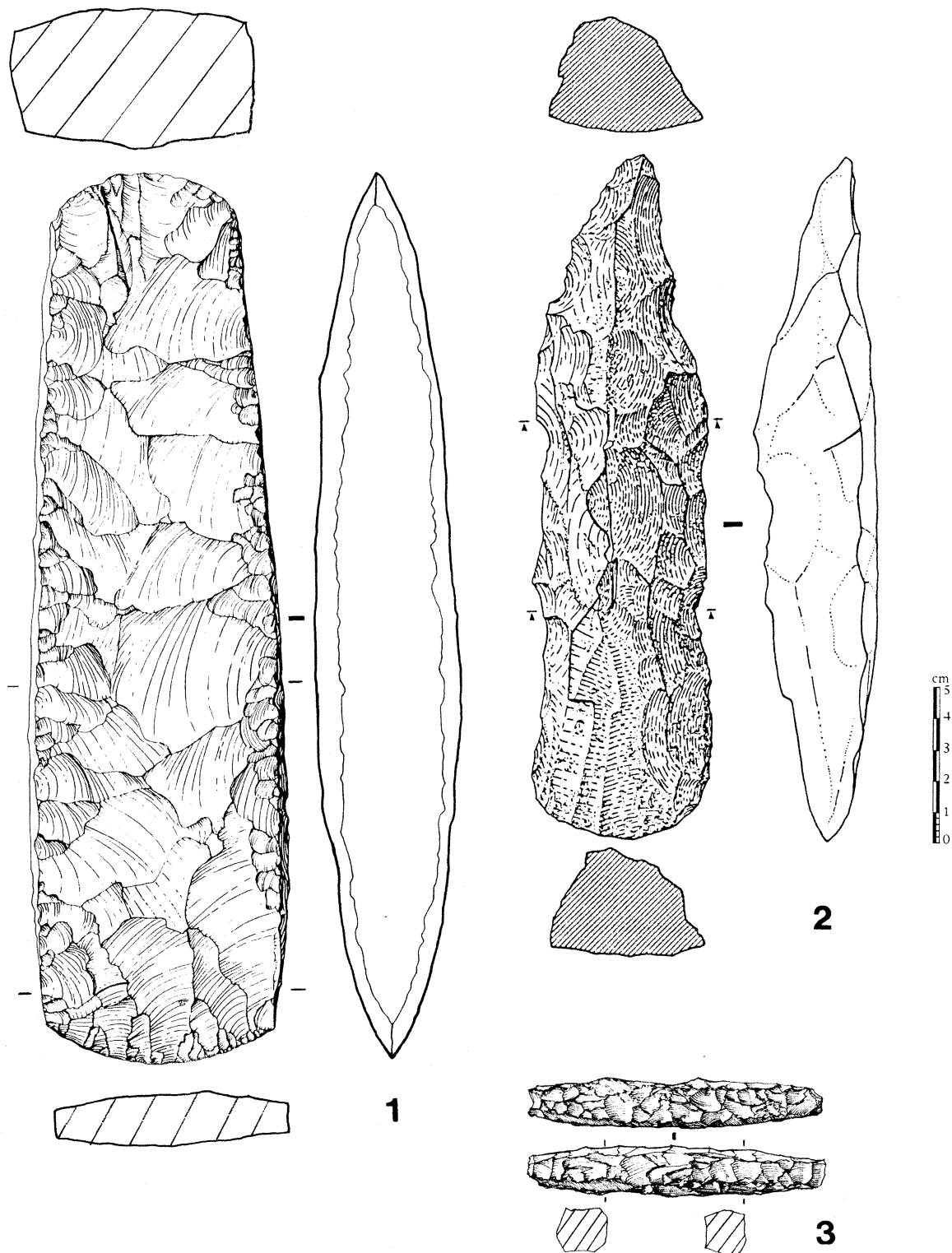

Fig. 18 — Preforms. 1 : experimental “square cross-section” stone axe preform, flint, Denmark. 2 : stone axe preform, basalt, Irian Jaya, Indonesia. 3 : bead preform, carnelian, Khambhat, India. 1 (Madsen, 1984 : fig. 4, A), 2 (Pétrequin and Pétrequin, 1993 : fig. 202).

- “Square cross-section” stone axes of the Danish Final Neolithic

The preforms of axes with a square cross-section (fig. 18 : 1) are prepared in the following way⁵⁰ : after some preliminary flaking of the block (chosen in relation to the anticipated size of the final product), the roughing out of the quadrangular shape is carried out by direct percussion with hammerstones whose weight will vary according to the different stages of the work. The shape of the roughout must be as close as possible to the ultimately desired morphology, because subsequent “corrections” are fraught with difficulties. The next step is the trimming of the preform, carried out by indirect percussion with a punch. Giving a regular shape to the ridges of the preform, which must be perfectly rectilinear, is done by applying light blows with a soft hammer, or by using indirect percussion or pressure. The preform is then ready for polishing, the latter being carried out by hand for small axes, or on a large polishing stone with a specific device for axes more than 20 cm long⁵¹. The whole process thus entails at least three different techniques.

- Egyptian predynastic knives

Another example, drawn from protohistoric times, is the complex *chaîne opératoire* of the Egyptian predynastic knives of the Gerzean period (about 3200 years BC)⁵², which involves the following steps : preliminary flaking of a block or slab of flint; roughing out and careful preparation of the preform (using direct percussion with a soft hammer for the latter two operations at least); polishing of the entire preform, which can be as long as 30 cm; preparation of the edges; application of pressure (probably with a copper instrument) to retouch one of the faces - the other remains polished - thereby producing long parallel S-shaped removals (ripple flakes), whose aesthetic function cannot be denied; fine denticulation of the working end.

- Polished axes from Irian Jaya (Indonesia)

A remarkable ethnographic example of *chaînes opératoires* concerned with the fashioning of polished axes and adzes has been recorded in Papua New Guinea⁵³ (fig. 18 : 2). In the west-central valleys of Irian Jaya, there exist groups who still manufacture axe, adze or chisel “blades”, applying four techniques whose ordering varies according to the raw materials and the technical abilities of each group : flaking (using direct percussion with a hard or soft hammerstone, or percussion on an anvil), pecking, polishing and sawing.

Following the collective procurement of the raw material, a process that can involve selective collecting, quarrying (digging of funnels or pits) or thermal shock (fire induced fragmentation), the main techniques (or combinations of techniques) used are : elaborate flaking and minimal polishing; minimal flaking and intensive polishing; minimal flaking or summary sawing and pecking, and intensive polishing; pecking only; sawing only; polishing only.

Once finished, the blades are variously hafted with wooden handles to make axes or adzes. Used for hewing down trees and splitting wood, these tools also play an important role in the exchange system and possess a highly symbolic value.

- Knapping of carnelian beads in India

The knapping of carnelian beads and trinkets is still practised today in Khambhat, in the Gujarat (India), and is very interesting from an ethnoarchaeological standpoint, in relation to archaeological data dating back to the third millenium of the Indus civilisation. Indeed, it has been possible to compare the contemporary workshops directly with some archeological workshops recovered from Chanhu Daro and Lothal⁵⁴.

The present day production line is the following⁵⁵. Vertical pits sometimes 15 m deep are dug into the fossil terraces of the Narmada (more than 100 km away from Khambhat), from which carnelian cobbles are quarried and then selected according to their size. They are heat-treated in order to improve the knapping characteristics of the stone, and can be subjected to the same treatment a number of times at any and all stages of the *chaîne opératoire* to alter the red of the carnelians. Knapping involves two steps, roughing out and making the preform

50 Hansen, Madsen, 1983.

51 Madsen, 1984.

52 Midant-Reynes, Tixier, 1981 ; Kelterborn, 1987.

53 Pétrequin, Pétrequin, 1993.

54 Mac Kay, 1943 ; Rao, 1973.

55 Roux, Pelegrin, 1989.

(fig. 18 : 3), using indirect percussion by counter-blow (p. 32). The preform has the main geometrical characteristics of the future bead, which can be square, circular, egg-shaped, cylindrical, etc., in cross-section, and its fashioning requires the use of a different iron rod (more pointed) and of a lighter mallet. It is then abraded, polished, pierced, and finally lusted. The rotary power needed for boring is still obtained with a bow-drill, which is already documented in the Neolithic.

The cleaver : a very specific tool

The cleaver owes its specificity to two main characteristics.

- It can be obtained either by debitage alone, or by debitage followed by shaping. We have therefore deemed it apposite to discuss this tool at the end of the chapter dealing with shaping, just before that dealing with debitage.

- Its cutting edge, the cleaver bit, must necessarily be unretouched. Bifacial pieces with a sharp bit achieved by shaping or by lateral tranchet blow technique actually are handaxes with a transverse (or terminal) cutting edge (*biface à biseau transversal ou terminal*), and not cleavers at all.

The cleaver is almost exclusively confined to the Acheulean. It is only very occasionally documented in the Middle Palaeolithic.

“It is clear that the manufacture of a cleaver is governed by a leading principle, that of obtaining a terminal cutting edge... This cutting edge, which is always intact, *i.e.* devoid of any intentional retouch, is the result of... the intersection of two planes : that of the fracture face and one of the planes of the upper face, which is the very definition of a flake tool... The removal of the flake whereby the cutting edge of the future tool is prepared is, from a cognitive viewpoint, a fundamental operation in the manufacture of a cleaver”⁵⁶.

Notwithstanding this very accurate description, published in the mid-fifties and complemented by a morphotechnical classification, cleavers are still heavily misinterpreted. Very common in some Acheulean industries, they are more often than not held to be handaxes and classified as such, in spite of the fact that their manufacture is dependant upon the debitage of a large flake (the blank of the cleaver-to-be). The blank is therefore strongly predetermined, whereas the part played by shaping is eminently variable.

Owing to its particular mode of manufacture, one of the cleaver’s morphological characteristics often is asymmetry, both bifacial and bilateral.

Some cleavers proceed from debitage alone, thus implying a high degree of predetermination in the production of the blank. This applies to cleavers made on flakes achieved by Levallois (p. 68 and ff.), Kombewa (p. 61 and fig. 28) or Tabelbala (p. 38 and p. 69) methods, but can also occur when the blanks are ordinary flakes. The edges may sometimes be made more regular by retouching.

On the other types of cleavers, with the exception of the proto-cleaver whose upper face is entirely cortical, the cleaver bit is the result of “the deliberately induced intersection of two surfaces : the lower face of the blank and the negative of a previous predetermining removal”⁵⁷. Once the blank is obtained, any degree of modification is possible, ranging from the summary paring down of the base of the blank (to thin or remove the bulb-and-butt part) and/or the trimming of the edges (to achieve greater regularity), to the entire bifacial shaping of the piece - with, of course, the exception of the cleaver bit, which always remains unmodified.

⁵⁶ “Le principe dominant qui a dirigé la fabrication d’un hachereau est, on le sait, l’obtention d’un tranchant terminal... Ce tranchant, qui est toujours naturel, c’est-à-dire exempt de retouches intentionnelles, est obtenu... par la rencontre de deux plans : plan de la face d’éclatement, et un des plans de la face supérieure, ce qui impose immuablement un outil sur éclat... L’enlèvement d’un éclat représentant la préparation du tranchant du futur outil est, psychiquement, l’acte essentiel dans l’obtention du hachereau”. Tixier, 1956 : 914-923.

⁵⁷ “[...] [résulte de] l’intersection volontairement provoquée de deux surfaces : la face inférieure de l’éclat support [qui] vient recouper le négatif laissé par le détachement préalable d’un éclat prédéterminant”. Texier, 1989 : 4.

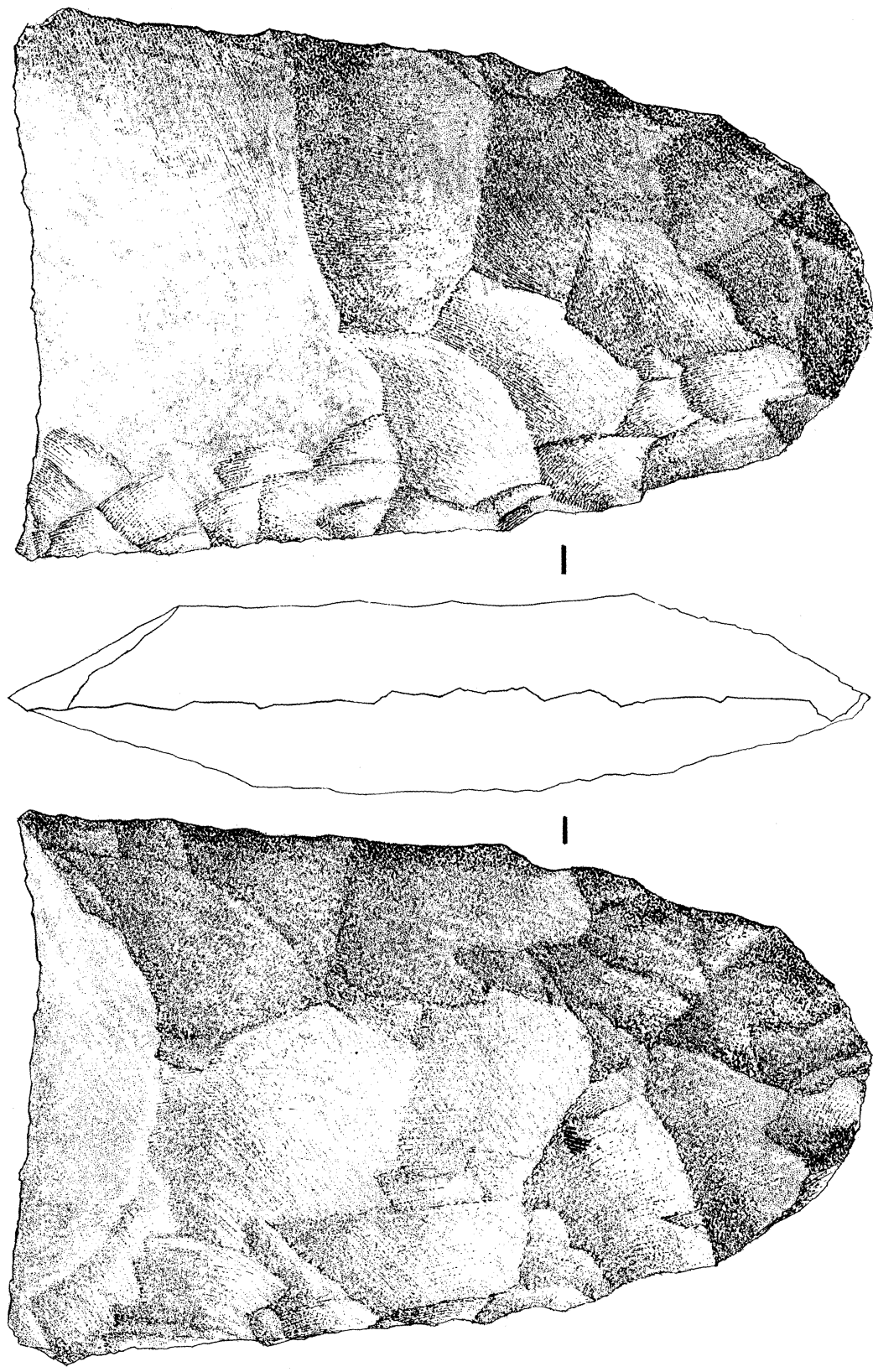
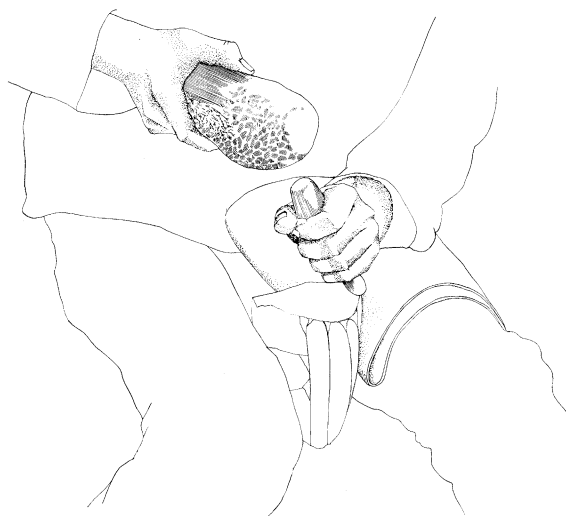

Fig. 19 — Phonolite cleaver, Acheulean, Isenya, Kenya.

As a rule, the part played by shaping is inversely proportional to the degree of predetermination of the blank. What “makes” a cleaver is the predetermination and not the shaping, whose (optional) function is, in this particular case, to add balance and regularity to the artefact.

The complexity of a stone tool is not necessarily dependant upon a long *chaîne opératoire*, and this is well exemplified by the cleaver. The tool looks deceptively simple, but actually proceeds from a very elaborate and efficient conceptual scheme.

Chapter 4



Debitage

Debitage is an operation that consists in fracturing a raw material in order to produce blanks. This conventional definition is appropriate only for products obtained intentionally by applying percussion and/or pressure. The term debitage is never used for breaks, even when the latter are intentional.

Debitage divides the raw material into two categories of complementary objects : the core and the debitage products.

Debitage often encompasses the following main phases : a phase concerned with the shaping out of the volume to be flaked, and the preparation of the striking or pressure platform(s); an initial phase of debitage; an optimal phase called “*plein débitage*”, which can be followed by a final phase. Further shaping out and preparation can occur throughout the entire debitage sequence. A certain number of flakes show distinctive features testifying to such operations and can thus be mentally situated in the *chaîne opératoire*.

The core

Whatever the raw material used, whatever the techniques and methods applied, and whatever the nature of the core-to-be (block, slab, flake, etc.), a core primarily displays negatives of the flakes that have been removed.

It can therefore be identified by recognizing (fig. 20) :

- the surface(s), whether prepared or not, on which force (percussion or pressure) has been applied : these are the striking or pressure platforms;
- the surfaces formed by the negatives of the flakes removed : these are the debitage surfaces;
- the surfaces flaked at an earlier stage, if present.

From a technological viewpoint, cores are debitage waste products. They reach us at the final stage of the debitage sequence and illustrate only the last moment of that sequence. Their

study should not be dissociated from that of unretouched products and tool blanks, if available. It must lead to the reconstruction of the production sequence(s) and of the operative scheme(s) brought into play.

Finally, one should not forget that flakes - if chosen for this purpose - can also serve as cores. When this is the case, they can only be identified as such if part of their lower (positive) faces can still be recognized.

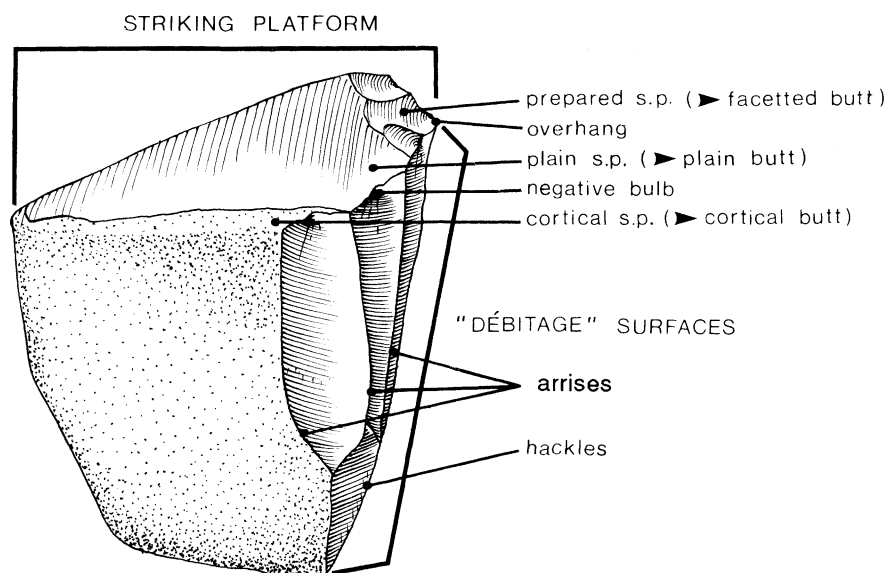

Fig. 20 — Main descriptive terms for cores.

Debitage products

By definition, these are products removed by pressure or percussion during debitage. They come under the general heading of "flakes", whether they be preparation flakes, blanks intended for future tools (used as such or subsequently modified), or characteristic waste products (fig. 9 and 10).

Debitage products can be classified according to the part they play in the *chaîne opératoire* : shaping out flakes, preparation flakes, tool blanks and finally waste products.

It is owing to the characteristics of some flakes and cores that prehistorians are able to reconstruct the debitage scheme intended for the manufacture of blanks.

Debitage methods

Like any technical action in stone-working, debitage is incorporated into a *chaîne opératoire*, for which an operative knapping scheme subtended by a project can always be recognized; this holds true whatever the period and the methods involved. The ever increasing range of knapping techniques invented and reinvented throughout prehistory is well documented; yet, major differences in the modes of conception and execution exist, which are not necessarily chronologically defined. To account for such differences, the contrast must be underlined between complex debitage operations (predetermined debitage) and simple debitage, requiring only a basic conceptual scheme and minimal skills.

1. Simple debitage

Flakes are produced without their removal being preceded by any special preparation of the core. Taking into consideration the morphology of the core, the craftsman will repeatedly choose where to strike in order to remove a flake that can be directly used or subsequently modified into a tool, carrying out the debitage as it comes (fig. 21). In theory, direct percussion is the only technique used for this type of debitage.

Cores will therefore not have a preferential striking platform, and will generally tend towards globular shapes if debitage is advanced enough. Flakes will have variable outlines and thicknesses, and shapes will not be stereotyped.

The lack of any preparation, of any shaping out of the core-to-be, obviously entails the almost complete absence of characteristic flakes (there will of course always be a first flake).

This is the simplest debitage mode conceivable, and it is therefore characteristic of no particular period or geographical region; with a bit of practice, it can be carried out by anyone who is not hopelessly clumsy.

“Discoidal” debitage is a little more elaborate, insofar as the method of producing flakes from disc-cores evinces a certain degree of predetermination. The frequency of such cores during the Middle Palaeolithic has led to their being called “Mousterian”; the term is inappropriate, for such a debitage mode existed long before the Mousterian and continued on long after; nor was it at all negligible during the Neolithic. The cores generally have a circular outline and an asymmetrical biconvex section: the less convex of the two faces is that formed by the removal negatives of the flakes, the other face often being cortical in the middle, with a margin formed by the preparation negatives of the striking platforms or by an area of cortex. The guiding principle is the removal of flakes by centripetally directed percussions. The debitage surface of the core shows several removal negatives with marked negative bulbs.

The raw material used must be quite thick for the method to be successfully carried out; nevertheless, the flakes will not have a standardized morphology.

2. Predetermined debitage

It aims at deliberately producing flakes of clearly set forms, thanks to an appropriate shaping out of the core. The notion that is central to this type of debitage is the production of pre-planned pieces, often standardized, whether single or multiple.

Within this general frame, each method is defined by the specific schemes (both conceptual and operative) brought into play, a particular volumetric conception of the core, and the resulting products.

We are only beginning to grasp how important the informations supplied by the different debitage methods can prove for our understanding of the management of raw materials or that of debitage products. Be that as it may, what we definitely gain some insight into, through the study of the different methods found in lithic industries, is prehistoric people’s technical behaviour. The methods discussed below are among the most widespread, the most characteristic or the best documented.

2.1. The Levallois methods

The type of debitage known as “Levallois”, which, according to a definition suggested by François Bordes in 1961⁵⁸, consists in the manufacture of a “flake of a form predetermined by special preparation of the core prior to the removal of that flake”, covers a time span of half a million years, as well as every inhabited continent except the Americas. Although the finds recovered as early as 1867 from the eponymous site of Levallois have made this Parisian suburb famous in prehistory, some credit should also go to Victor Commont who first reconstructed this particular type of debitage in 1909.

Levallois debitage has long been poorly understood, and was sometimes considered as just a special way of preparing the striking platform. Moreover, the term “predetermined flake”

58 “*éclat de forme prédéterminée par une préparation spéciale du nucléus avant enlèvement de cet éclat*”. Bordes, 1961 : 14.

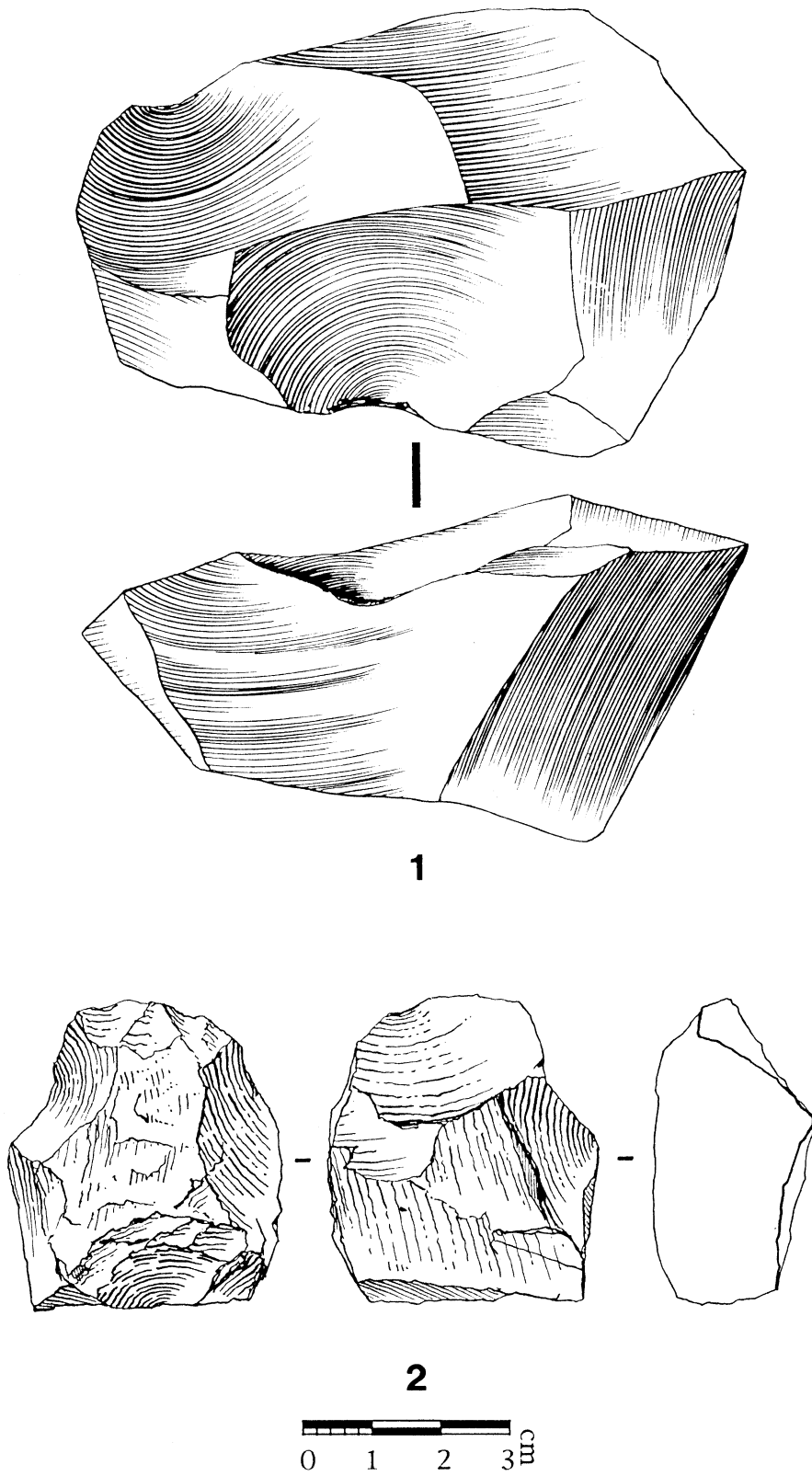

Fig. 21 — Relatively simple debitage. 1 : theoretical core, no specific morphology, multidirectional percussion. 2 : flake-core, Oldowan, Nyabosusi, Ouganda.

was currently equated with “Levallois flake” and vice-versa, with complete disregard for the fact that the concept of predetermination is involved in every knapping operation, in which the final product has been mentally planned beforehand. While the idea of predetermination is indisputable in blade debitage, it must nevertheless be acknowledged that Levallois debitage is the first well organized, very widespread debitage method to develop before the advent of *Homo sapiens*. However, although Levallois debitage belongs essentially to the Lower and Middle Palaeolithic, it cannot be used as a chronological marker, for it is also met with during the Upper Palaeolithic, and even in very recent industries⁵⁹. Over the last twenty years, the discovery of many Levallois debitage industries, mainly in Europe and the Middle East, has shown there is an ever increasing discrepancy between Bordes’ definition and the more recently recorded Levallois products. It therefore became more and more difficult for prehistorians to grasp, and to agree upon, the very definition of Levallois debitage.

Faced with this problem, E. Boëda⁶⁰ attempted a technological approach to Levallois debitage, based on experimental data and on the analysis of archaeological series from the Middle Palaeolithic in northern France, in order to clarify the origin and subsequent developments of this debitage method. His assessment of the purpose of so complex a debitage, as well as his investigations into the various knapping strategies carried out, enabled him not only to specify Bordes’ definition, but above all to widen its scope.

The old definition insisted upon the centripetal preparation of the Levallois surface and the special preparation of the striking platform.

- The centripetal preparation does indeed ensure that the debitage surface has a convex morphology, thereby permitting the removal of a large “Levallois” flake. However, centripetal removals are not a constant feature in Levallois debitage.

- Great emphasis was also placed on the preparation of the striking platform (irrespective of that of the debitage surface) to achieve an ideal flake.

This part of the definition was too narrow insofar as it dealt with only one debitage method, that which was concerned with the production of a single flake (although the manufacture of several flakes ensuing from the same type of preparation was occasionally mentioned). It also suggested that Levallois debitage was “wasteful”, using up large amounts of raw material.

- Levallois products were as often as not described in terms of morphology, such as the “turtle-back” core or the “*chapeau de gendarme*” butt, although these morphologies result from a series of connected technical actions, which were not explained. The “turtle” is evidence that the core was shaped out by means of two asymmetrical convexities, and the “*chapeau de gendarme*” is a technical facetting procedure for preparing a preferential striking platform, in order to carry out the removal of a Levallois flake.

- As a consequence, the existing typological classification of the Levallois method was based on the form of the final products obtained : flake, point, and blade Levallois methods.

Mindful of the original conception of this type of debitage, the study of which included cores and predetermined products rather than the latter alone, E. Boëda, after J. Tixier⁶¹, suggested that the following terms be singled out and defined : concept, technique and method⁶². He thereby brought to light the varied character of the Levallois “methods”.

The Levallois concept

Whatever the morphotechnical characteristics of the wished-for products, Levallois debitage is dependant upon a particular volumetric conception of the core and the way it is worked.

- The core is shaped out by means of two asymmetrical convex surfaces, which define a plane of intersection (fig. 22 : 1). The convexity of the two surfaces is a deciding factor in the production of Levallois flakes.

59 Cauvin, 1971.

60 Boëda, 1994.

61 Tixier, 1967 : 807 and 817.

62 Boëda, 1988.

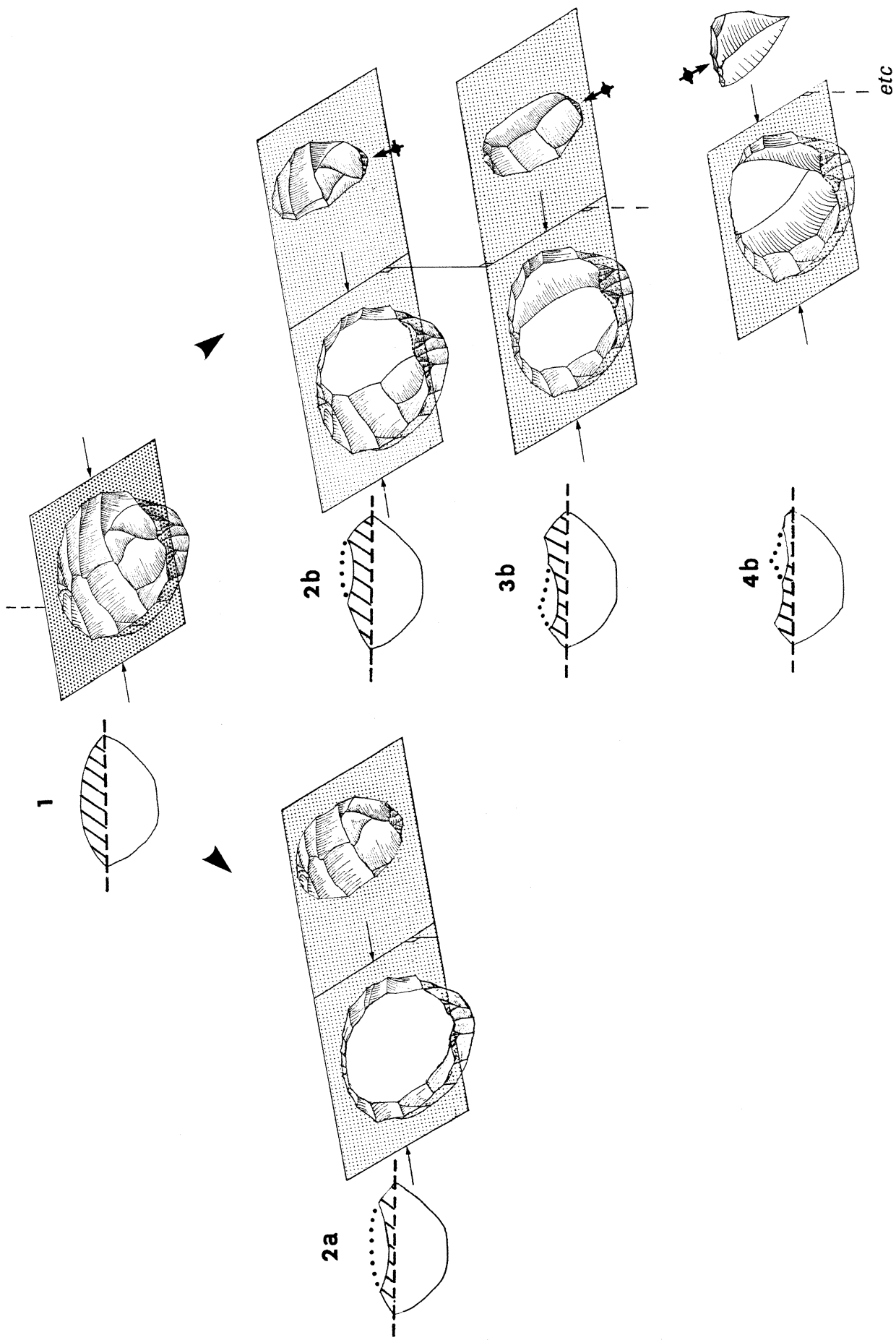

Fig. 22 — Volumetric representation of two Levallois debitage methods. 1 : prepared core. 2a : debitage of a preferential flake. 2b, 3b, 4b : recurrent bipolar debitage (after Boëda, 1994 : fig. 1).

One of the surfaces is the debitage surface from which the Levallois products are removed; the other becomes the striking platform, which can be used with or without further preparation. The two surfaces are not interchangeable during a production sequence of Levallois flakes.

It is therefore quite clear that, starting with the shaping out of the core, the preparation flakes play a major role : indeed, the quality of the Levallois products is closely dependant upon the preciseness of the sequence of such previous removals.

- Levallois products split off along a fracture plane that is parallel or sub-parallel to the plane of intersection defined by the two convex surfaces described above. In figure 22, this fracture plane is symbolized by a dashed line. “The discontinuity between the Levallois preparation surface and the preparation surfaces of the striking platforms entails that neither of the two surfaces can increase in size at the expense of the other. Thus, the capacity of a Levallois core for predetermined flakes is restricted to the volume contained between the Levallois preparation surface and the plane of intersection of the two surfaces”⁶³ (fig. 22, hatched surfaces).

The technique

Levallois debitage is *exclusively* carried out using direct percussion with a stone hammer, even though percussion with a soft hammer is perfectly well controlled at the same period and used concurrently for the manufacture of other pieces.

The methods

The term method applies to the carefully thought out sequence of actions that leads to the manufacture of Levallois flakes. The production modes implemented according to the above defined Levallois concept are the materialization of the various methods observed.

Two main methods have been recognized, showing some variations in their operative schemes.

- Levallois debitage of a preferential flake (fig. 22 : 2a, fig. 23 and fig. 26 : 1)

The aim is the manufacture of a single flake from each prepared debitage surface. The butt of the flake is small relative to the total surface that is in principle planned for it, and the flake spans most of the debitage surface. Figure 23a shows the creation of the two convex surfaces by means of centripetal removals, 23b showing the preparation of the striking platform (also carried out by means of centripetal removals) and the final shaping out of the debitage surface. In 23c, the Levallois flake removal operation is shown. If the volume of the core allows the manufacture of another flake, the entire process must be gone through once again before the second flake is removed. When within a single assemblage the products obtained correspond to a single flake for each prepared surface, the method is referred to as “lineal”.

- Multiple-flake Levallois debitage (fig. 22 : 2b, 3b, 4b and fig. 24)

The Levallois surface is in that case intended to yield a series of Levallois flakes. Each removal is a function of the preceding removal, and conditions the following removal. This type of debitage is called the *recurrent Levallois method*.

Figures 24a and 24b show the creation of the two convex surfaces, 24c showing the final shaping out of the debitage surface. Figures 24d and 24e show the removal of several Levallois flakes (in this case centripetal).

In the recurrent Levallois method, the multiple flakes will have different morphologies according to the orientation of their removals, and the position(s) and size(s) of the striking platform(s).

63 “La discontinuité entre la surface [de préparation] Levallois et la surface de préparation des plans de frappe a pour conséquence qu’aucune de ces deux surfaces ne peut s’agrandir aux dépens de l’autre. Ainsi la capacité d’éclats prédéterminés d’un nucléus Levallois se réduit au volume compris entre la surface de préparation Levallois et le plan d’intersection des deux surfaces”. Boëda, 1988 : 14.

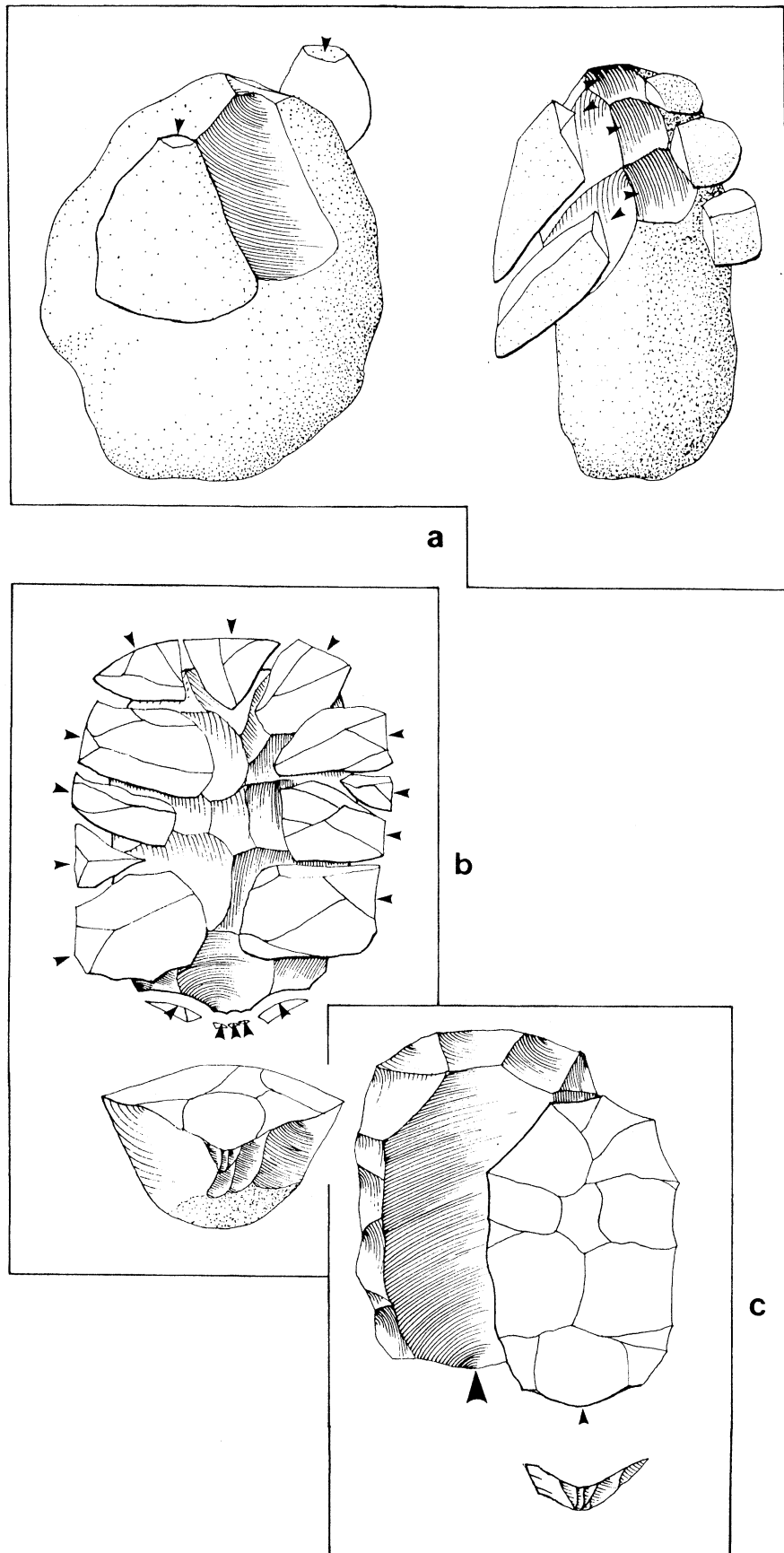

Fig. 23 — Levallois debitage of a preferential flake.

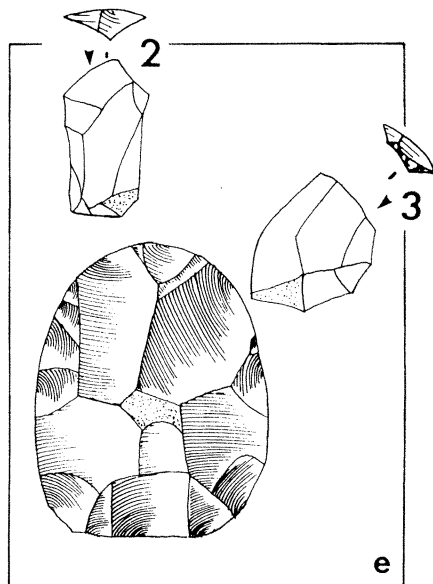
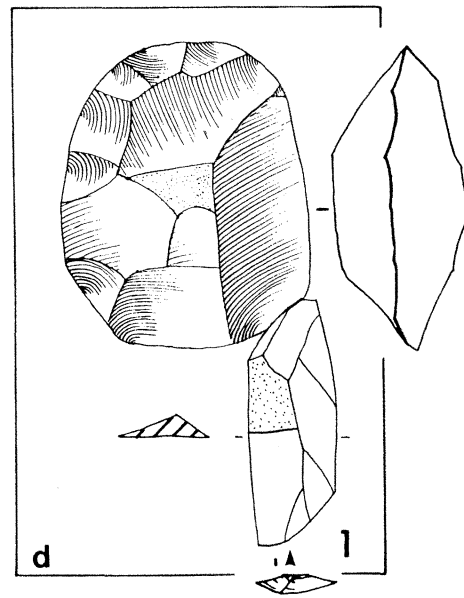
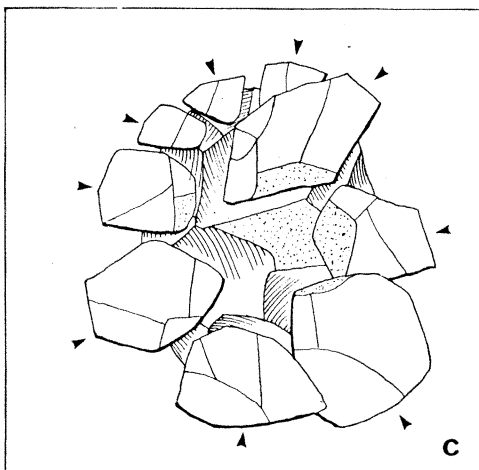
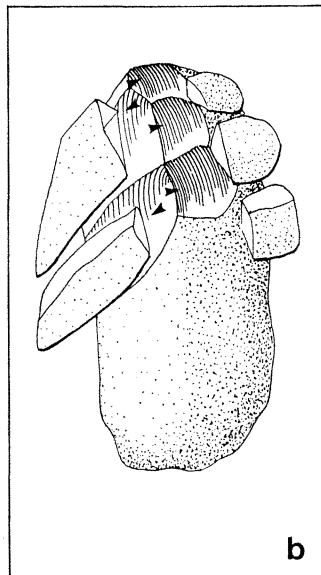
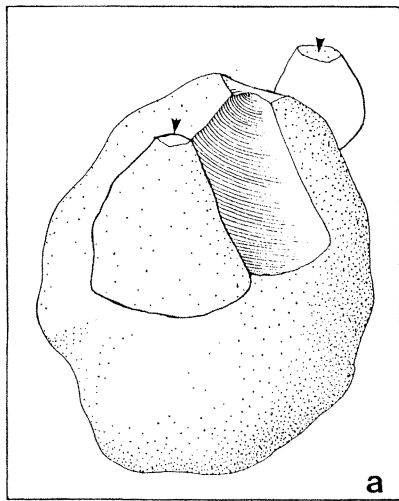

Fig. 24 — Recurrent centripetal Levallois debitage.

1. Recurrent unipolar Levallois method

The flakes have a single direction of removal, and tend to be elongated. The striking platform is small. If the directions of the removals converge slightly, the flakes will be triangular in shape. Levallois points often proceed from this type of knapping scheme, and more rarely from bipolar preparation. Such a method is documented in the Sudano-Egyptian region⁶⁴ and in the Near East⁶⁵ for instance (fig. 26 : 2).

2. Recurrent bipolar Levallois method (fig. 22 : 4b)

Flakes that originate from two opposed preferential striking platforms can be observed, the direction of removal being visible on the upper faces of the flakes. Levallois blades are traditionally achieved by means of such a method : it can be noted that in Levallois blade debitage, the ridges created by the intersection of the two convex surfaces do not serve as a crested blade (see under : blade debitage).

3. Recurrent centripetal Levallois method (fig. 24)

The margin of the entire surface selected as the striking platform can be used, but confusion must be avoided with discoidal debitage : the specifically Levallois character of the method lies in the debitage surface being exploited in such a way as to ensure that it remains always in the same debitage plane.

4. Levallois point

More than in any other Levallois method, the predetermination of the morphology and exact delineation of a Levallois point depends upon the pattern of arrises displayed by the core (fig. 25). As any fracture wave tends to follow these arrises (formed by the secant planes of removal negatives of Levallois preparation), a flake removed along a rectilinear arris will necessarily have a triangular delineation and a pointed distal end. Used to produce Levallois points, this is the principle of the “guiding arris”, whose preparation thus theoretically requires at least two removals. In practise, there is very often a “basal triangle” formed by a negative bulb. This concave surface, related to the preparation of a preferential striking platform, provides a wide butt (of the “*chapeau de gendarme*” type), and sides that converge nicely to a point.

Figure 26-2 illustrates one the many recorded variants, resulting from the chosen sequence of preparation removals and their orientation.

Levallois points can occur fortuitously during debitage, whether the latter be Levallois (during the preparation of the striking platform) or not. In this event, basal triangles are usually lacking.

To define the methods and procedures of debitage, flakes are useful sources of information, but it is the cores that provide the most reliable information on knapping schemes and methods, on condition that they have not been re-used.

Covering a time span of 500 000 years, the different Levallois methods testify to the early development of intelligence in mankind. They not only make it possible to characterize cultures, but also further our insight into prehistoric people's technical behaviour.

2.2. The Kombewa method

Less well known than the Levallois methods, the Kombewa method is mainly documented in Africa, where it antecedes the Levallois method⁶⁶. It combines simplicity with originality.

The basic principles of the method can be summarized thus : from a regularly convex surface, it is possible to remove a very regular circular, semi-circular or oval flake. Such a surface can be created by means of a percussion that intentionally achieves a pronounced, wide and

64 Marks, 1968 : 315-323.

65 Meignen, 1995.

66 Owen, 1938 ; Balout, Biberson, Tixier, 1967 ; Dauvois, 1981.

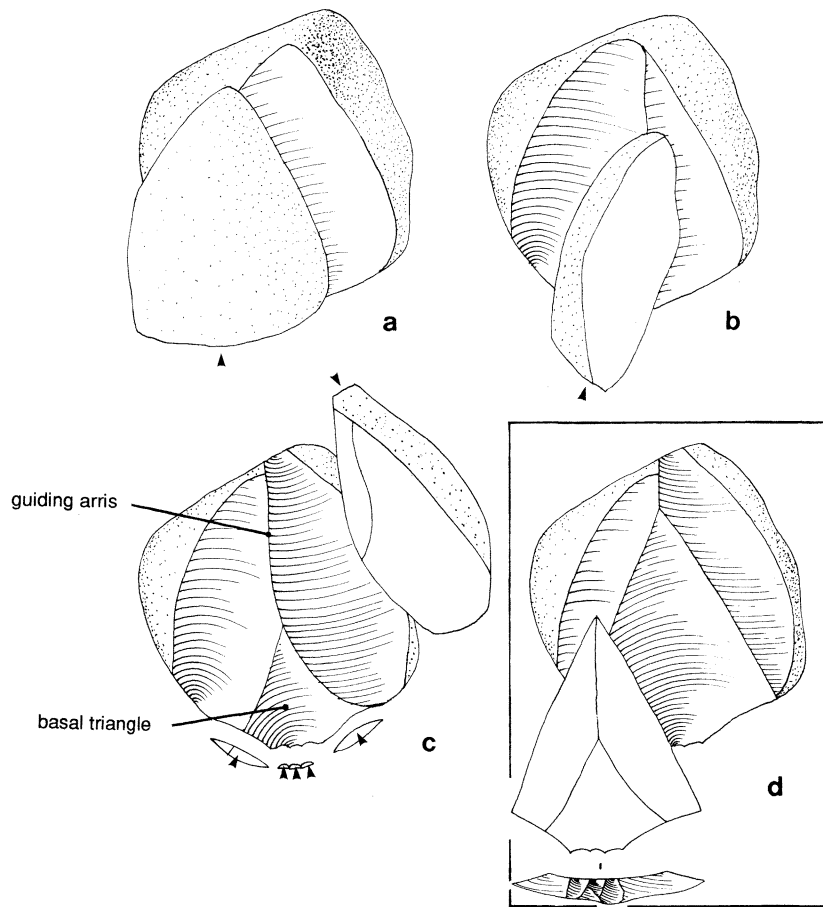

Fig. 25 — Debitage of a Levallois point.

regularly convex bulb. It is therefore by using the convexity of the lower face of this first flake that the shape and thickness of a second flake (or several successive flakes) can be predetermined (fig. 27).

After the debitage of the flake whose lower face will serve as a debitage surface, and before the removal of the Kombewa flake, a striking platform can be prepared, but this is an optional step. The two impacts that removed first the core-flake, and then the Kombewa flake, can be oriented in any direction relative to one another.

The manufacture of cleavers is one of the main purposes of the big Kombewa flakes of the African Acheulean (fig. 28). A few rare examples show that the Kombewa method, in combination with the Levallois method for the shape of the flake, was used to manufacture cleavers of the Tabelbala type (an intentionally plunging Levallois flake)⁶⁷. In that case the upper face is mostly formed by the convexity of a large percussion bulb instead of being prepared by predetermining removals.

The expression “Kombewa method” (based on the expression “Levallois method”) is relevant whenever there is evidence for the clear intention to predetermine, and therefore produce, Kombewa flakes. This is for instance the case for some French Mousterian pieces⁶⁸, for the *mata'a* tanged obsidian pieces from Easter Island (fig. 49 : 3), for some gun flints from Britain or from the Vaucluse in France, and for the flints used in Spain for threshing sledges.

67 Tixier, 1956; Alimen, 1978.

68 Bordes, 1961 and 1975; Geneste, 1985.

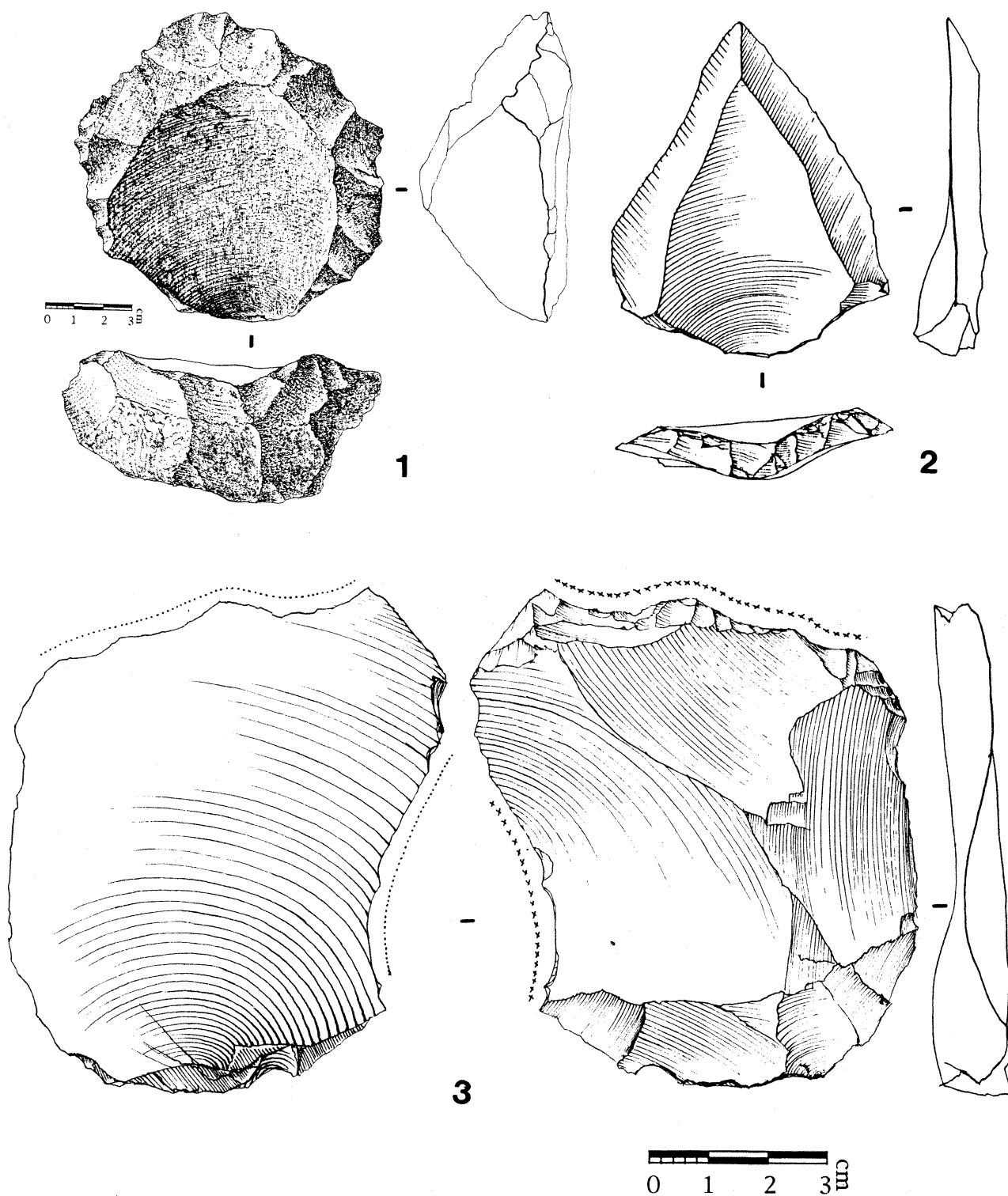

Fig. 26 — Various examples of Levallois products. 1 : preferential-flake Levallois core, sandstone, Ain Chebli, Morocco. 2 : Levallois point, flint, Kebara, Israel (Meignen, 1995). 3 : Levallois flake, flint, recurrent centripetal debitage; bearing macro and microscopic wear traces resulting from butchering activities, La Combette, Vaucluse.

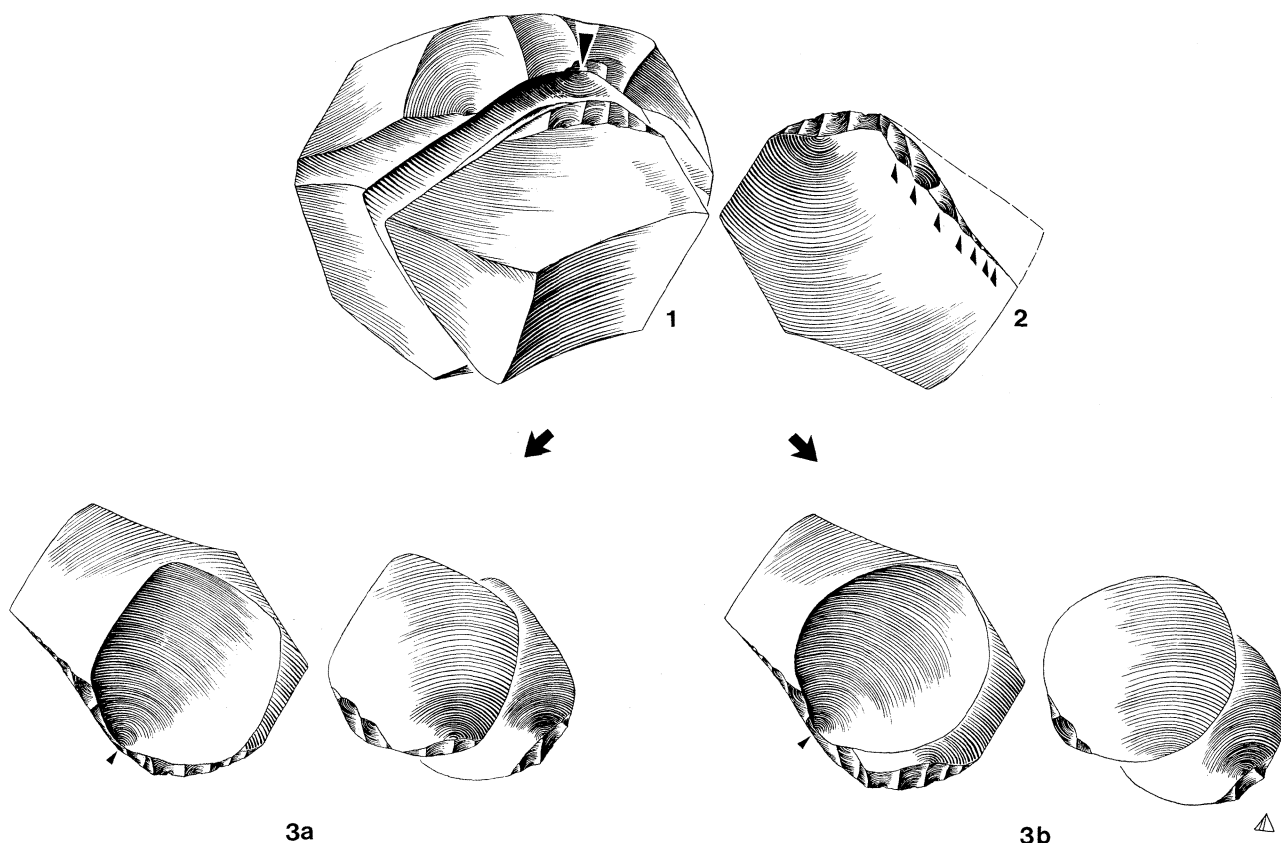

Fig. 27 — Debitage of a Kombewa flake.

However, the transformation of a flake into a bifacial piece, or even a core, can bring about the “chance” removal of a flake from the bulb. This is then referred to as a “Kombewa waste product”.

Finally, some fair-sized “flakes”, which originate from the splintering of a large bulb, can be open to misinterpretation; however, they have no butt, and can thus be identified as bulbar splinters, a variety of “parasitical” flakes.

2.3. Blade debitage

Blade debitage is a pre-planned debitage, organized in such a way as to repeatedly produce blades or bladelets from a single core⁶⁹ (fig. 9 and 10).

Of standardized form owing to their (almost) parallel arrises, blades and bladelets are flakes whose length is at least equal to twice their width, according to a widely adopted convention. They can be removed by any type of technique (direct percussion, using a hammer of stone, wood, antler or metal; indirect percussion; pressure).

The mere presence of a few “laminar” products is not sufficient to vindicate the diagnosis of blade debitage; for the diagnosis to be borne out, the presence of characteristic scars and systematic blade blank production is necessary.

Long assimilated with Upper Palaeolithic blade debitage by percussion, the so-called “classical” blade debitage has a very different volumetric conception from Levallois blade debitage: the products are stereotyped and the entire volume of the core can be used, with a wide choice of debitage volumes and striking platforms.

69 *Economie du débitage laminaire*, 1984.

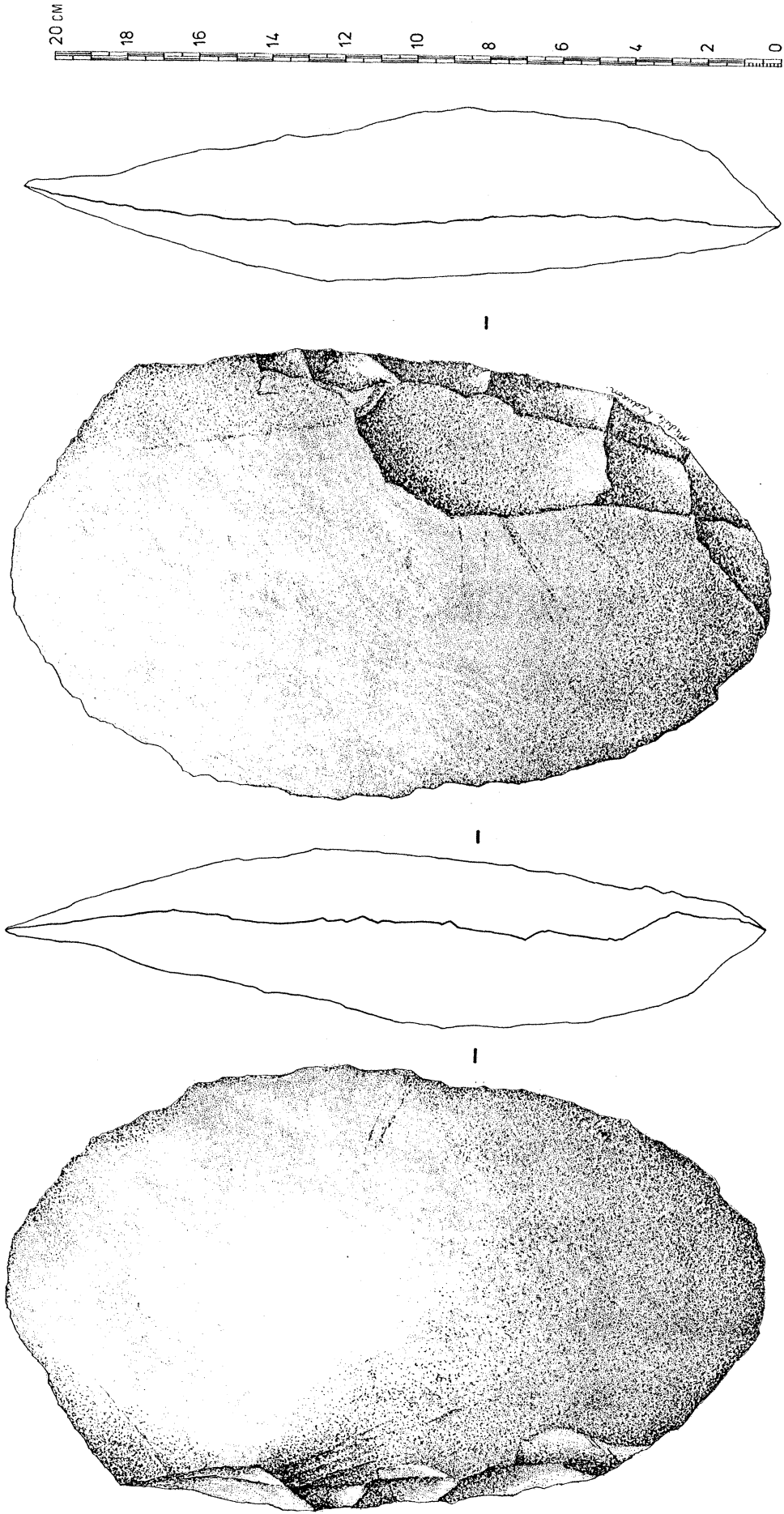

Fig. 28 — Phonolite cleaver on a Kombewa flake, Acheulean, Isenya, Kenya.

While the distinction between blades, and bladelets and micro-bladelets is a matter of size, it has been shown that in many prehistoric regions there was a technical choice of either large debitage products (blades) or small ones (bladelets and micro-bladelets), the choice being irrespective of the dimensions of the available raw materials. A statistical analysis of the sizes of blade products can distinguish the relevant dimensions for these categories and help to state more clearly the choices made by the prehistoric groups concerned. Conventions can then be established, which are valid for one or more cultures within a prehistoric region. This has been attempted for the Epipalaeolithic of the Maghreb by one of the contributors⁷⁰. Regretfully, and in spite of his cautionary recommendations, some authors have assumed that the figures put forth could be generally applied in any other context.

The manufacture of blade products at will can rarely be achieved using a piece of raw material in its natural condition. Blade debitage is generally linked to the shaping out of the core, and to the preparation of striking or pressure platforms, and most particularly to the preparation, almost always by bifacial removals, of one or more “ridges”, called crests. However, owing to the presence of a sufficiently convex area of cortex, some morphologies of raw material are directly suitable for blade debitage; this is the case, for instance, in some Aurignacian *chaînes opératoires*.

The *crest* makes the debitage of the first blade easier, enabling it to split off along the crude dihedral formed by the two series of removals (fig. 64 : 1 and 2). This first *crested blade* will therefore always be triangular in cross-section (fig. 64 : 2b). Nevertheless, if the raw material is appropriate, as are some slabs, no such preparation will be necessary. The first blade will then be referred to as *naturally crested*, or if only one versant is prepared the crest will be called a *crest with one prepared versant* (fig. 64 : 6b).

When struck off, the crest will leave two arrises, along which debitage can be continued. The subsequent blades may still show removal negatives from the shaping out of the crest (fig. 64 : 3b and 4b). This crest can be made as long, or as curved, or as precise as is desired, depending on what is required. If a part of the core no longer allows satisfactory debitage, the core can be shaped out a second time, often with a new crest created by removals stemming from a previous blade removal negative.

A core can be preformed with one, two, or three crests; even four crests are not inconceivable⁷¹. While all the crests (when there are several) play a part in the shaping out of the volume of the core, only one is used to start the production of blades. Such crests are therefore an essential stage in blade debitage. The more care given to the preparation of the crest (or crests), the more regular the shape of the blades (beginning with the earlier stages of the debitage).

The crested blade is thus a characteristic flake.

The striking or pressure platform

Blade debitage is carried out from one or more striking or pressure platforms, which can be cortical, plain, or prepared. The abrasion of an overhang (a preparation procedure) can be applied to any type of striking or pressure platform, and should never be confused with traces of use.

Percussion debitage of blades

The removal of blades is achieved by direct or indirect percussion, using a hard or soft hammer.

In the percussion method of blade debitage, as practised in many Upper Palaeolithic industries, the volume of the core is prepared in such a way as to permit its complete reduction. The maximum length of the blades will be a function of the initial volume of the lump of raw material, and will diminish until the core is spent, the state of reduction depending on the size of the intended products.

70 Tixier, 1963.

71 Crabtree, 1968.

In the repeated production of blades or bladelets, certain laws (rediscovered by experimentation) were imposed on the prehistoric knappers. Such laws tend towards :

- ensuring an adequate morphology of the edge of the striking platform for groups of two or three blades, or single blades, by means of various technical procedures, which are often the signature of cultural traditions;

- maintaining for each blade removed both an adequate core morphology (transversal and longitudinal convexities - “*cintrage*” and “*carénage*”) and relatively parallel arrises, to allow further debitage.

The mastery of blade debitage is dependant upon the control of the distal ends (which must not be hinged, or debitage will very quickly grind to a halt) and the longitudinal curvature (“*carénage*”), in accordance with the type of product that is wished for.

If a slight distal curve on the blank is sought - to retouch an endscraper for instance -, or if this is of no consequence, the end of the core opposite the striking platform can bear a second striking platform. This “opposite” striking platform is only used for putting imperfections right - these are very often hinge negatives - by corrective removals. The distinction should therefore be recognized between this second subsidiary striking platform and the true blade debitage striking platform.

If more rectilinear blades are sought, two opposite striking platforms are created, both intended for blade debitage. They are then used alternately for short production series, so that the distal ends overlap in such a way as to create debitage surfaces with very little convexity, as in Upper Perigordian cores (fig. 29 : 2) or in the naviform cores of the Near East.

One should also bear in mind that a systematic sequence of blades cannot be produced unless the transversal convexity (perpendicular to the arrises) is sufficient. Blade debitage is impossible once the debitage surface has become too flat. In a similar way, it is necessary that the convexity of the distal ends of the arrises (the longitudinal curvature) be maintained; this can be achieved either through debitage itself, or by means of removals in the area opposite the main striking platform. In the long run, this imposes the need to remove blades from the parts of the debitage surface adjoining the sides (whether cortical or prepared) of the core.

Direct percussion with a hard hammer

Obviously, this is the oldest technique, known in the context of the Middle Palaeolithic, about 100000 years ago; the striking platforms were prepared. The technique later appears sporadically, in the European Azilian, for instance, usually with plain striking platforms. It is also documented in far more recent industries : hard hammers were used for making long obsidian blades (30 cm) in northern Mexico and in Ethiopia. The marks are the same as those displayed by flakes : a relatively large butt (even if the projection crowning the negative bulbs has been removed), a point of impact, a bulb and bulb scars nearly always quite pronounced.

One should also consider the varying degrees of hardness of the hammerstones, for the scars they leave on the products can now be recognized⁷². Debitage using a soft hammerstone is a technique that appears to have developed towards the end of the Upper Palaeolithic in Europe; it has also been used, so it seems, in the naviform debitage of the Levant.

Direct percussion with a soft hammer

This technique, which is the prevailing one in the Upper Palaeolithic, results in small butts, a flaking angle of more than 90°, and a diffuse bulb (the same holds true for flakes). Direct percussion with a soft hammer often goes together with the abrasion of the overhang, whatever the technical procedure used to obtain the latter : preparation of a small projection on the debitage surface, negative bulb(s) on the striking platform proceeding from localized resharpenings, or spurs. The importance of such procedures depends on the nature of the intended products, especially if very large blades are in demand.

In the present state of experimental knowledge, the largest prehistoric flint blades obtained by percussion are over 50 cm long, whereas those obtained by pressure barely reach 20 cm. For late periods, however, the use of a lever can be considered in the case of outside blades, particularly if they are very regular (p. 32).

72 Crabtree, 1972; Madsen, 1983; Pelegrin, 1991a.

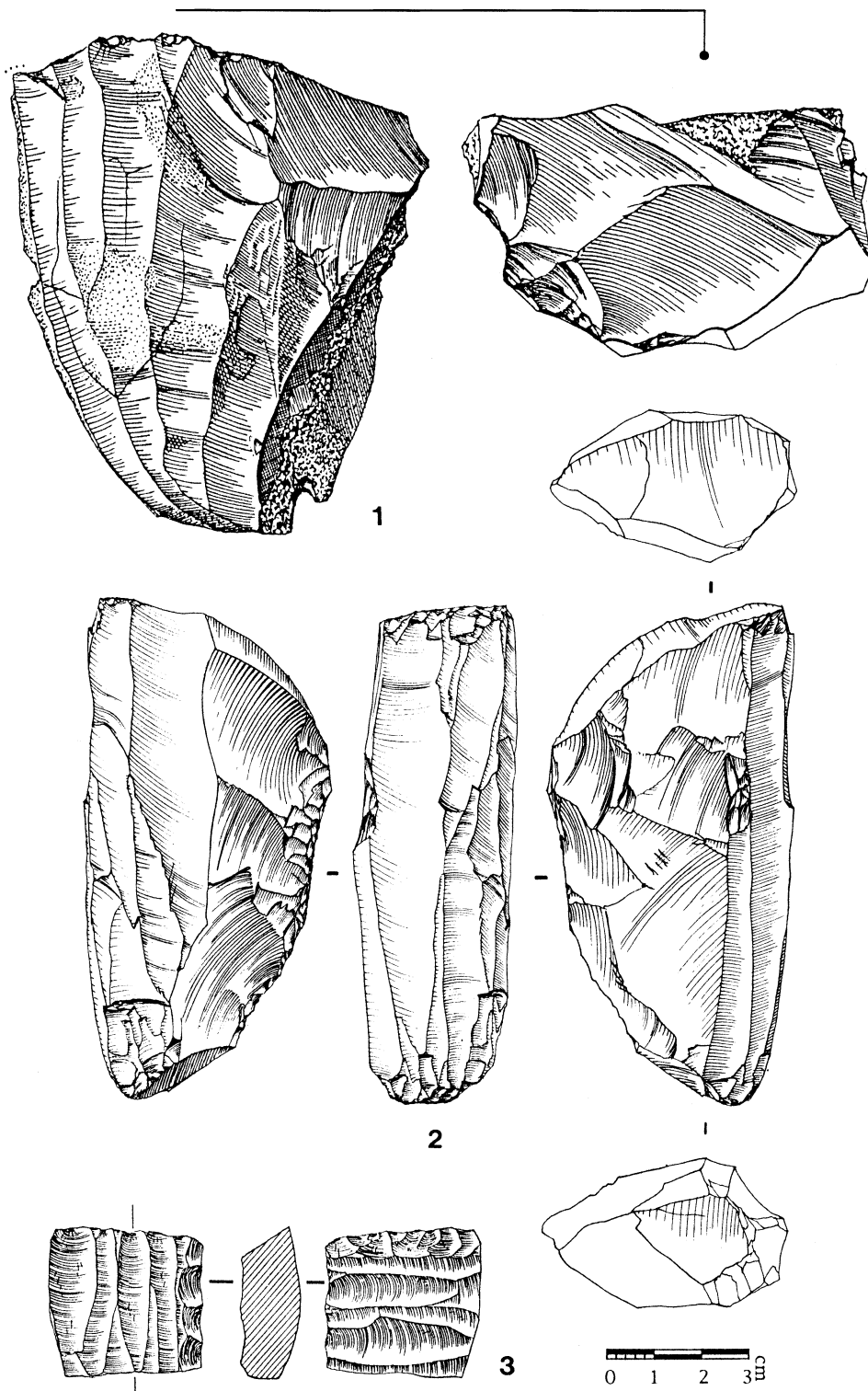

Fig. 29 — Various types of blade-cores produced by percussion. 1 : pyramidal core, Aurignacian, Bergeracois flint, Corbiac-Vignoble 2, Dordogne. 2 : prismatic core, Perigordian, Bergeracois flint, Aillas, Dordogne. 3 : core with two orthogonal platforms and two debitage surfaces.

Indirect percussion

Strangely enough, there is no indisputable evidence for blade debitage using a punch before the Mesolithic. The distinctive features of such blade products are halfway between those of debitage by direct percussion and by pressure-flaking, and are sometimes difficult to distinguish from either of the two. Indirect percussion is well adapted to a plain striking platform, only slightly inclined on the debitage surfaces. The flaking angle is almost 90°, and is one of the criteria by which this technique can be distinguished, in a long debitage series, from direct percussion with a soft hammer.

We have chosen to illustrate just three examples.

- Debitage starting from a single striking platform, on a pyramidal core (fig. 29 : 1). With this kind of pattern, the blade products tend to curve.

- Debitage starting from two opposite striking platforms on a cylindrical or prismatic core (fig. 29 : 2). Debitage can be performed either by alternating the striking platforms for each removal, or by removing a series of products from first one platform and then the other. The products obtained in this manner will be rectilinear.

- Crossed debitage : the two debitage surfaces are parallel, but the directions of percussion are orthogonal (fig. 29 : 3).

Blade debitage can be carried out from one or more striking platforms, which can be cortical, plain, or prepared. In the latter case, preparation will involve either a short series of two or three blades, or a single blade as is common in the Magdalenian (especially the Upper Magdalenian), where a projection is created on the edge of the striking platform. Part of this projection is removed along with the blade, which will then have a butt with a spur (fig. 62 : 8).

Pressure debitage of blades

Pressure debitage applies only to the manufacture of blades and bladelets. Identified relatively late⁷³, this technique has, in the last few years, become more and more widely documented, in space and in time. The most impressive area of distribution covers the Middle and Far East. Until very recently, it seemed that pressure debitage of blades followed percussion debitage of blades, and appeared only 12000 years ago, in Japan. At present, its invention can be traced to a Sibero-Sino-Mongolian region of Asia, about 25000 years ago⁷⁴. Invented by hunter-gatherers, this type of debitage moreover proves to be a valuable technical marker, thus providing added information about the peopling of North America⁷⁵.

Heat treatment, already known to make pressure-retouching easier, is also often associated with pressure debitage, at least on flints and chalcedonies.

In the case of bladelet manufacture, the pressure causing the fracture wave can be applied directly with a short hand-crutch (fig. 30 : 1), or with a longer shoulder-crutch, whose “passive” end is held firm under the arm or presses against the shoulder (fig. 30 : 2). For longer blades, the pressure is applied with a pectoral (fig. 30 : 4) or abdominal crutch (fig. 30 : 3a and 5). The point that applies the pressure can be of ivory or antler, which were superseded by metals when these appeared. As the size of the products increases, it becomes more and more necessary to stabilize the core (fig. 30 : 3b).

Pressure debitage therefore requires more equipment than percussion debitage : a device to immobilize the core, a composite tool to apply pressure. Furthermore, the frequent occurrence of heat treatment testifies to complex and well mastered skills. However, in spite of the improvement heat treatment can bring about, pressure debitage requires raw material that is both fine-grained and homogeneous. Obsidian is certainly the best suited material for this type of debitage.

Owing to the fine nuances of movement and force that can be applied, and to the accuracy with which the pressure point can be positioned, pressure debitage leads to maximum

73 For the background history, see Tixier, 1984 : 57-70.

74 Inizan, 1991.

75 Inizan, Lechevallier, Plumet, 1992.

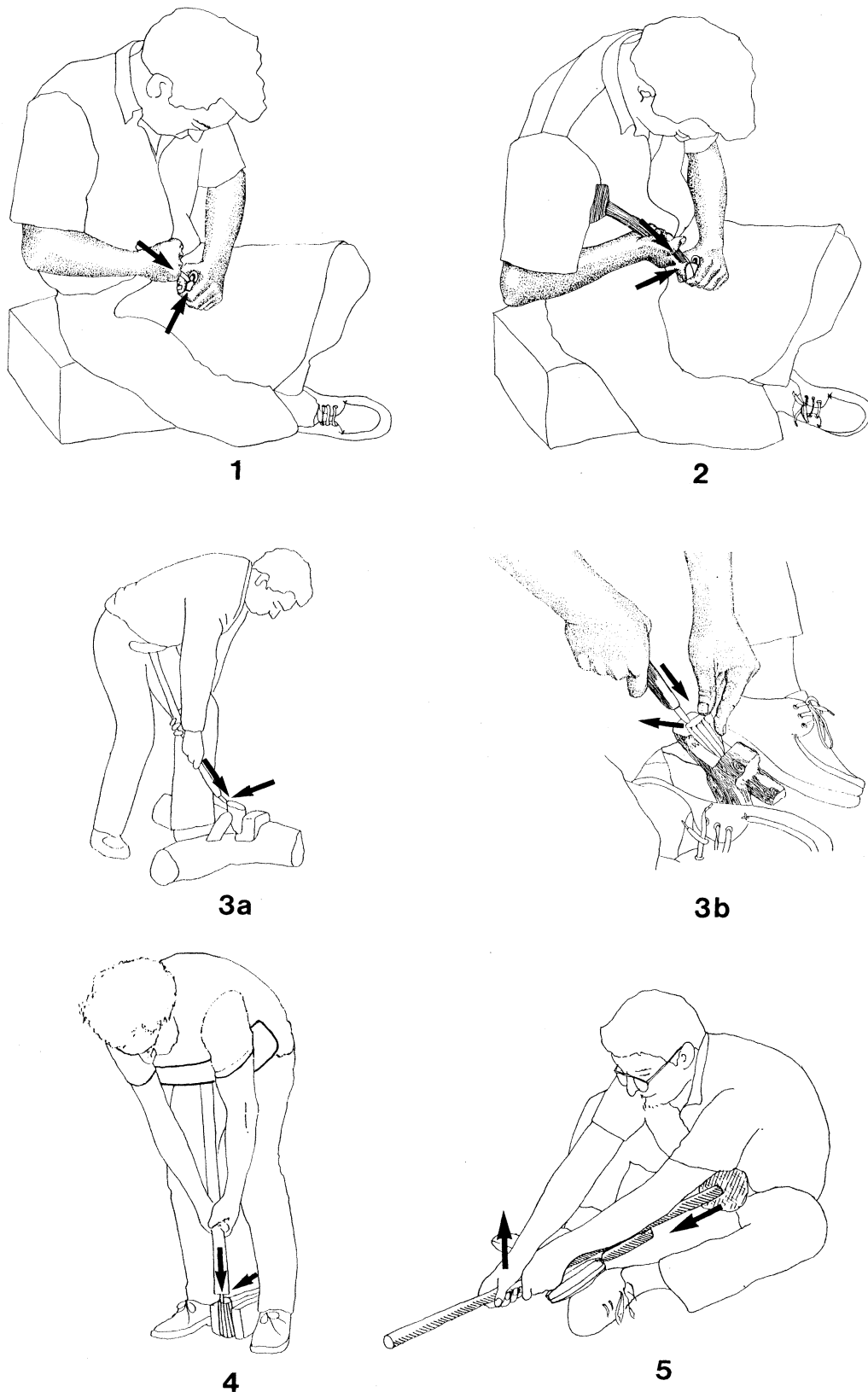

Fig. 30 — Experimental blade and bladelet debitage positions. 1 : using a grooved device and applying pressure with a small hand-held tool. 2 : using a shoulder-crutch. 3a : using an abdominal crutch. 3b : immobilizing the core (detail). 4 : using a pectoral crutch. 5 : using an abdominal crutch, with the core held firm between the feet. (1, 2, 3 : J. Pelegrin; 4 : J. Tixier; 5 : J.E. Clark).

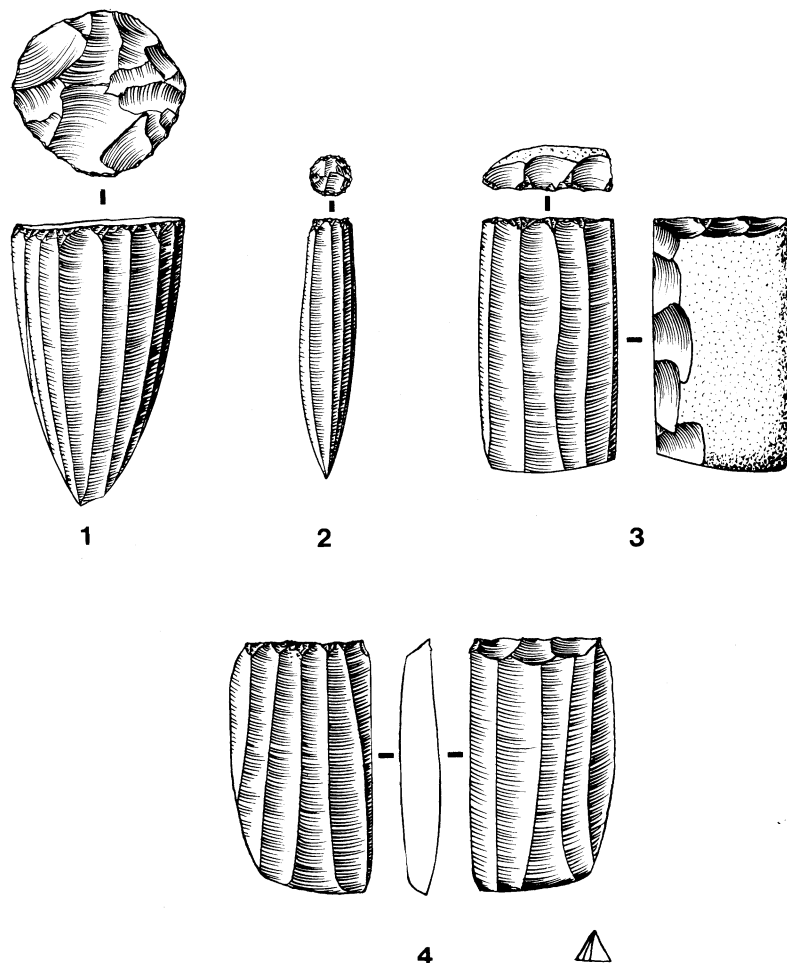

Fig. 31 — Pressure debitage of blades (or bladelets), different types of cores. 1 : pyramidal core. 2 : bullet core. 3 : flat core. 4 : flat core with two successive debitage surfaces.

precision and maximum standardization, thanks to parallel arrises. It is also a much more profitable technique than percussion debitage; it actually allows an “ideal” blade debitage, removing two arrises from the core while creating two more.

More than any other debitage technique, pressure-flaking gave rise to feats of imagination, reflected in the various ways of shaping out different sized cores, in the rubbing down of pressure platforms when obsidian is used, and in the polishing of some parts of the core during debitage to smooth out irregularities⁷⁶ (fig. 78).

Because pressure-flaking is a technique that allows the core to be worked until it is spent (as the large number of documented bullet cores shows), plunging is a common accident. It is therefore unthinkable and illogical to pressure-flake from two opposite pressure platforms.

Recognition criteria⁷⁷

On the core

Very rectilinear and regularly parallel arrises help to distinguish a pressure-flaked core from a percussion-flaked core, while the morphology itself can be variable (fig. 31).

⁷⁶ Inizan, Tixier, 1983.

⁷⁷ J. Tixier's first assessment of the recognition criteria of this technique was based on the Upper Capsian lithic industry of the Ain Dokkara (Tixier, 1976a).

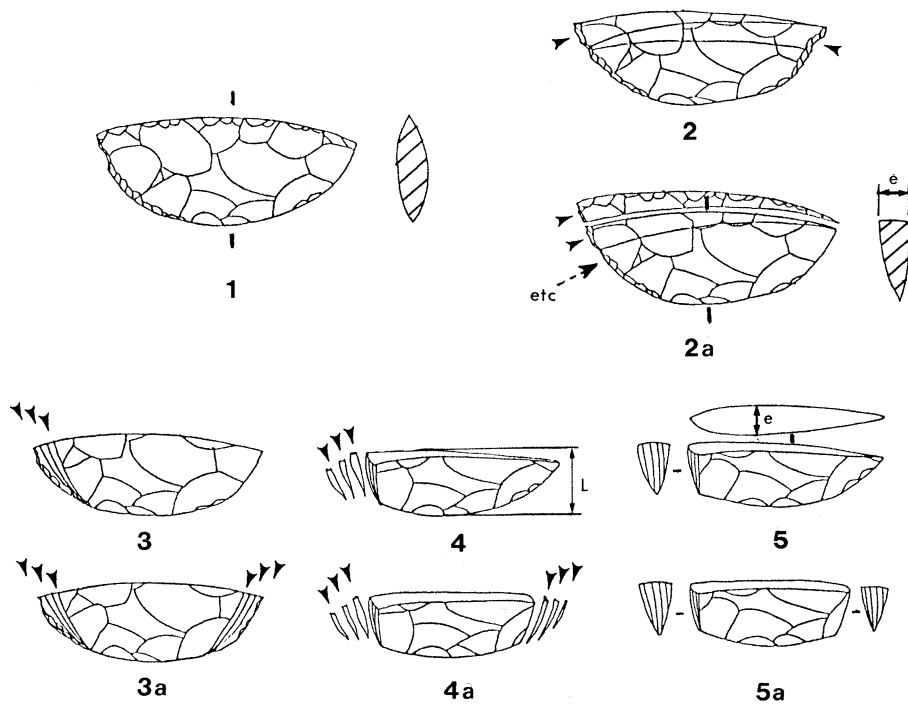

Fig. 32 — The Yubetsu method. 1 : shaped out core. 2 : removal of a crested blade and successive “ski spalls”, to prepare the pressure platform. 3, 4, 5 : bladelet debitage.

To be worthy of such a name, a pressure-flaked core should always be undisputably fluted in places.

Pressure platforms can be cortical, plain or prepared. In the case of vitreous rocks like obsidian, the pressure platform is very often partially or completely rubbed down, to avoid slipping during debitage. The action often extends to the overhang of the core, or even to part of the debitage surface (fig. 78). Rubbing down of the pressure platform and overhang is only rarely documented for flint cores.

The two basic forms of cores are the pyramid and the parallelepiped.

Pyramidal cores : either have a circular pressure platform and ogival shape (fig. 31 : 1), end result of a core that has been shaped out like a “mitre”; or are virtually cylindrical bullet cores with a very much smaller pressure platform by the time debitage is finished (fig. 31 : 2).

Parallelepipedal cores, which are described as “flat”, have a single debitage surface, or two successive ones, as recorded in the Greek Bronze Age (fig. 31 : 3 and 4).

On blades and bladelets of “plein débitage”

- parallel edges and arrises, which tend to be rectilinear;
- constant thickness, mesial section included;
- no obvious ripples on the lower face;
- a butt always narrower than the maximum width of the blades, which is very rapidly reached.

The Yubetsu method

The name “Yubetsu” is not intended to have any connotations regarding the geographical area in which the method appeared, but simply refers to the fact that it was first recognized as a method of pressure debitage in Japan⁷⁸. Indeed, it is now acknowledged that this original debitage

⁷⁸ Akazawa *et al.*, 1980.

method was invented in a Sibero-Mongolian area during the Upper Palaeolithic. While there is but a single conception underlying this type of bladelet debitage, many variants have been identified, which stand for cultural markers, as in Japan for instance.

The main stages of the operative scheme are the following.

- The raw material is shaped out by means of bifacial percussion removals, resulting in a more or less regular, often asymmetrical, leaf-shaped bifacial piece (fig. 32 : 1).

- The least convex ridge of this “biface” is then removed, usually by successive removals called “ski spalls”. In cross-section, the first removal (akin to a crested blade) is triangular, and the following removals are trapezoidal (fig. 32 : 2). Such removals are characteristic enough for the debitage scheme to be reconstructed, even in the absence of refits.

- The negatives of these characteristic blades are used as a pressure platform to remove the bladelets (fig. 32 : 3 and 4).

- The first bladelet displays negatives of the bifacial removals from the other ridge of the biface; this is a first crest, as defined in blade debitage.

- The narrow cross-section of the biface offers but a small debitage surface, which is why the core has such a specific shape, known as a “wedge-shaped core” (fig. 32 : 5).

As debitage is carried out along the width of the biface, and as the debitage surface is no larger than the cross-section of the core, the blade products are of relatively constant length, but small in size.

Chapter 5

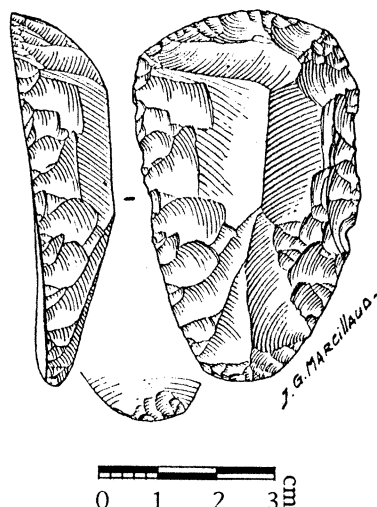

Retouching

Definition

The term “retouch” describes removals obtained by percussion or pressure, with the intention of making, finishing or sharpening tools. The terms retouch and retouched will therefore by definition be applied to any object that is presumed to be a tool.

Retouching modifies a blank, whether natural or intentionally obtained by knapping. A retouch will have the negative morphological characteristics of a removal, a term that remains general enough not to presuppose the purpose involved in the action. Removals can be single or repeated, depending on the techniques.

Removals can derive from actions prior to the finishing of the tool (preparation), or from a later action, such as use or mechanical damage. It is sometimes very difficult to distinguish the latter from manufacturing retouches. Caution and elementary logic should therefore be the rule : retouches or traces of use should only be referred to as such when there is clear evidence or proof. The same applies to “spontaneous removals”.

Characteristics

“Characteristics” refers to a coherent set of terms used to describe a retouch or a line of retouches. There are seven such terms : *delineation*, *extent*, *angle*, *localization*, *morphology*, *position* and *distribution*. Each of these characteristics is further defined by a series of descriptors.

The list of descriptors should cover all removals. In different combinations, they allow the classification of tools. We do not claim the list to be exhaustive, as it depends on the available means of examination. It should also be noted that some combinations of descriptors pertaining to different characteristics are incompatible, for instance invasive (extent), and abrupt (angle).

These seven characteristics, as well as the possible combinations of descriptors (see p. 87), are necessary to accurately describe a tool, but their appreciation remains very personal. All the terms are defined in the lexicon.

Orientation of tools

The retouch that characterizes some tools plays an important part in their orientation, but once again no logical or fixed rules have yet been established.

The position of the piece while being drawn or examined varies according to the different authors, as do descriptions of tools, which begin either with the retouch or the blank, sometimes even alternating the two.

Nevertheless, for the reproduction of a tool to be more conveniently interpreted and understood, it is necessary to adopt a certain number of symbols, and to define them clearly when they are not in current use (ch. 7, fig. 53).

Special techniques and their products

Some special debitage techniques and methods, such as the manufacture of crested blades (fig. 68) and the rejuvenation of striking or pressure platforms (fig. 77), leave characteristic and easily recognizable waste products. In a similar way, some retouching techniques (*lato sensu*) leave such characteristic negative marks, and corresponding waste products, that they deserve a special, separate place in stone-working technology.

Some retouch flakes have specific morphologies, which are in themselves sufficient to characterize the technique used. For instance, it is quite easy to recognize flakes resulting from “Quina” retouch : they are fan-shaped, with a hinged distal end (fig. 34 : 5 and 6).

A number of special techniques were used in tool making, and they sometimes mark the ultimate stage of manufacture. They are also sometimes difficult to distinguish from knapping accidents. Note the case of intentional fractures caused by flexion or any other process : the fractured element can be used directly, or transformed by retouch.

Our aim is not to establish an exhaustive explanatory list of such techniques, but to highlight their importance by illustrating a few examples. As waste products are still thought of as the “poor relatives” of lithic assemblages, it is certain that a good number of special techniques are still undiscovered...

This is not the case for the famous microburin, known since 1875⁷⁹, and about which thousands of pages have been written.

1. Microburin blow technique

This special technique is very widespread in the Old World, but has not yet been documented in the New World. Although it was used for making various types of tools (see below), it is primarily associated with the manufacture of geometrical microliths : mainly triangles and trapezes, but also crescents. Any prehistorian confronted with such shapes should therefore keep an even sharper lookout for microburins among the knapping products.

The purpose of the microburin blow (a technique that was perhaps born from the repetition of a common knapping accident occurring during the manufacture of artefacts with backed edges), is to achieve a technical morphology known as a “*piquant-trièdre*”⁸⁰.

A flake, blade or bladelet is placed on an anvil with an open dihedral angle (*e.g.* a flake with a triangular cross-section lying on its lower face, a block of stone, a wooden board), its upper face in contact with the ridge of the dihedral angle so that the axis of the blade or bladelet

79 Chierici, 1875.

80 Gobert, 1955.

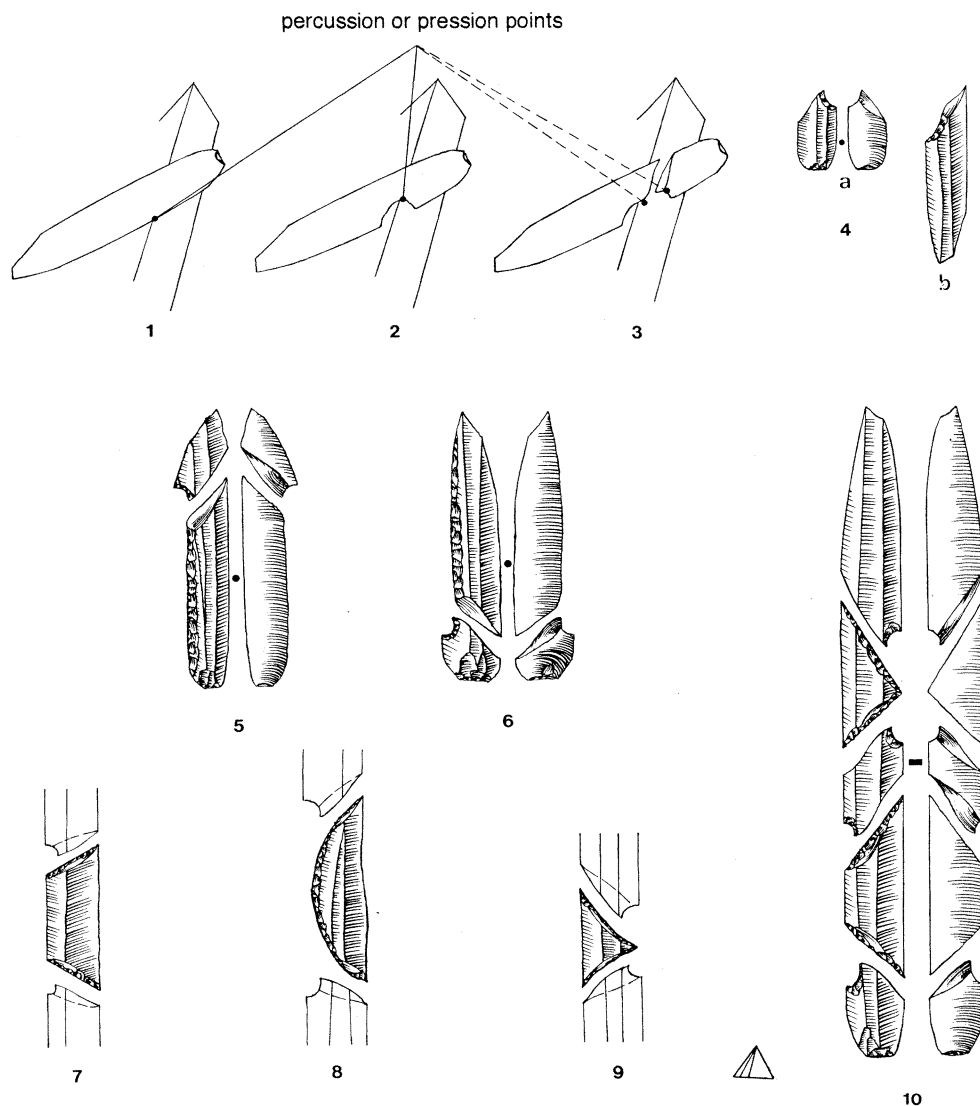

Fig. 33 — Microburin blow technique. Production scheme of a microburin (4a) and a “*piquant-trièdre*” (4b) by percussion or pressure on one edge of a blade resting on an anvil (1, 2, 3). Using this technique to obtain a backed blade with a distal (5) or proximal (6) “*piquant-trièdre*”, a trapeze, a crescent or a triangle (7, 8, 9). 10 : production of a triangle and a trapeze on the same blade; from top to bottom : distal microburin, triangle, double microburin, trapeze, proximal microburin (Tixier *et al.*, 1976b : fig. 16).

is diagonal to the ridge. The near end of the tool is held in the hand, while the further end juts out over the ridge to the desired extent and falls off after fracture (fig. 33 : 1 to 3).

With a small hammer, chosen relatively flat, small blows are repeatedly applied almost perpendicularly to the nearer edge of the blade or bladelet, level with the ridge of the anvil. A notch is thus created, which is deepened until spontaneous fracture occurs, slightly beyond the point of contact of the blade or bladelet with the anvil; not the slightest modulation in the blows or the path of the hammer is required during this operation. The fracture, which roughly follows the ridge of the anvil, is therefore oblique to the axis of the blade or bladelet. When the microburin blow is successful, the fracture is also oblique to the faces of the blade or bladelet. It can be seen on the upper face of the part that remains in the hand, which is a blade or bladelet with a “*piquant-trièdre*” (fig. 33 : 4b) (the purpose of the operation), as well as on the lower face of the part that falls off, namely the microburin (fig. 33 : 4a). Such a result can also be achieved by applying pressure with a tool of wood, bone or antler.

If the microburin blow has removed the bulb-and-butt part, the microburin is termed proximal; the removal of the opposite end results in a distal microburin (fig. 33 : 5).

On its upper face, a microburin displays part of a notch with direct retouches, while the lower face shows a fracture facet extending from the hollow of the notch to the opposite edge. A proximal microburin therefore often has a slightly asymmetrical, escutcheon-like morphology (fig. 33 : 6).

The most important part of a microburin is the fracture facet, on which any diagnosis must be based. Besides being oblique both to the axis and the faces of the blade or bladelet, it must display all the characteristics of a fracture face : small to very small bulb, sometimes quite flat, common occurrence of hackles fanning out from the bulb, hardly noticeable fracture ripples. The facet is often twisted, and very slightly hinged where it meets the upper face of the blade or bladelet. The use of a stereoscopic microscope may be necessary to appreciate this tiny convexity, more prominent in its central part, to which corresponds, on the “*piquant-trièdre*”, a ridge that separates the fracture facet from the upper face. Running one’s nail across the ridge is a useful trick : if the nail catches against the ridge, this will generally confirm the presence of a “*piquant-trièdre*” (the nail does not catch against normal debitage arrises).

Another characteristic of the fracture facet of the microburin is the frequent presence of fine direct retouches, or even of a shallow notch, located near the vertex of the angle formed by the fracture facet and what is left of the notch. Such “retouches” have often been used as an argument by those who insisted that the microburin was not a waste product, and who thus tried to prove it was used as a tool. Knapping experiments have shown that spontaneous removals could be generated by the very blow that produces the microburin. Reacting to the blow of the hammer, the microburin sometimes acts as a lever within a fraction of a second after fracture; the part formed by the fracture facet and the upper face presses down on the ridge of the anvil, and this is sufficient to produce a small continuous retouch, up to 1 cm long. A microburin can thus fall off already “retouched” by what really are spontaneous removals.

Several types of blunders can occur : pronounced hinging, inverted angle of the fracture facet, fracture perpendicular to the axis and the two faces of the blank, etc.

2. Burin blow technique

This follows the same principles as debitage : using as a striking or pressure platform one of the surfaces (natural or prepared) of a blank, a usually elongated fragment, called “burin spall” (fig. 61), is removed by pressure or percussion along an edge or a line of preparation. By such means, one or more *burin facets* are produced. A burin blow can be applied by direct percussion of the hammer, or by striking the burin-to-be against a hammer held stationary in the hand, or even by pressure. Frequently, several burin facets can be produced on a single blank by means of the burin blow, and as any position is possible, combinations of surfaces are innumerable (see lexicon). Since a single burin blow can produce several spalls, sharpening by one or more burin blows can only be proved by means of refits and/or the presence of traces of use - except perhaps in the case of complete repair (for instance, a truncated burin with a new burin blow applied on the other edge, fig. 79 : 5). Although systematically recorded, the characteristics waste products of burins – *spalls* and *sharpening spalls* – are rarely included in the technological analysis of a lithic assemblage.

Stylistic variations are virtually infinite, and in the west European Upper Palaeolithic some very special types of burins (*e.g.* : “carinated”, “*Noailles*”, “parrot’s beak”), being short-lived, are characteristic of certain periods.

The burin waste products - spalls and sharpening spalls - can be retouched, and thus become tools. For instance, such spalls can be excellent blanks for the production of drill-bits.

The use of this technique does not necessarily imply the manufacture of a tool. Indeed, if it can be shown that the production of blanks is intended, the burin is referred to as a core. At the Neolithic site of Lagreich (Mali)⁸¹, all the burins are cores for the production of spalls, which were used for pecking holes in carnelian beads. It is quite plausible to consider that burins could be used both as tools and as cores. The idea that burins must be equated with tools, and spalls

81 Gaussen, Gaussen, 1965.

with waste, is now outdated; burins and their spalls form a pair, whose use and purposes can vary according to the different cultures. However, the principle remains, demonstrated yet again, that a technique furthers an intention towards various ends.

3. Tranchet blow technique

On one of the edges of a triangular and elongated axe-shaped bifacial (or bifacially retouched) piece, a blow is applied close to the edge that acts as the cutting edge. This causes a removal negative at an acute angle to the face that was struck, thus creating a sharp cutting edge perpendicular to the axis of the piece (fig. 34 : 1). In some cases, this is a resharpening technique.

An identical technique applied near the point on Acheulean handaxes, either on one face or alternating on both, has been named the “lateral tranchet blow” (fig. 34 : 2). This technique, which is a lot more common than one might have thought (10% of the handaxes in the Somme valley, France⁸²) always results in a roughly symmetrical final shape; it therefore represents the ultimate intention, whether resharpening is involved or not. The resulting waste products have a characteristic morphology.

4. Clactonian notch technique

It is too often forgotten that the simple action of striking a flake quite far from the edge, on either of the faces, creates a notch that consists of a single removal negative, known as a Clactonian notch. The resulting characteristic waste products are indicative of the technique (fig. 34 : 4). Amongst other possibilities, this technique can be used to reshape the transversal convexity (“*cintrage*”) of the front of a carinated endscraper (fig. 34 : 7).

5. Other techniques

- The “channel-flaking” of some projectile points (fig. 63) or their basal thinning, are two examples of special techniques, with characteristic waste products, specific to the Americas.

- “Obsidian side-blow blade-flaking” (fig. 34 : 3), a special technique of repeated Clactonian truncation, is the fracture of a pressure-flaked obsidian blade perpendicularly to its debitage axis, by a blow usually applied in the middle of its upper face. In the present state of knowledge, such a technique is the signature of cultural traditions with a limited existence in both time and space (pre-pottery Neolithic of northern Mesopotamia).

82 Zuate y Zuber, 1972.

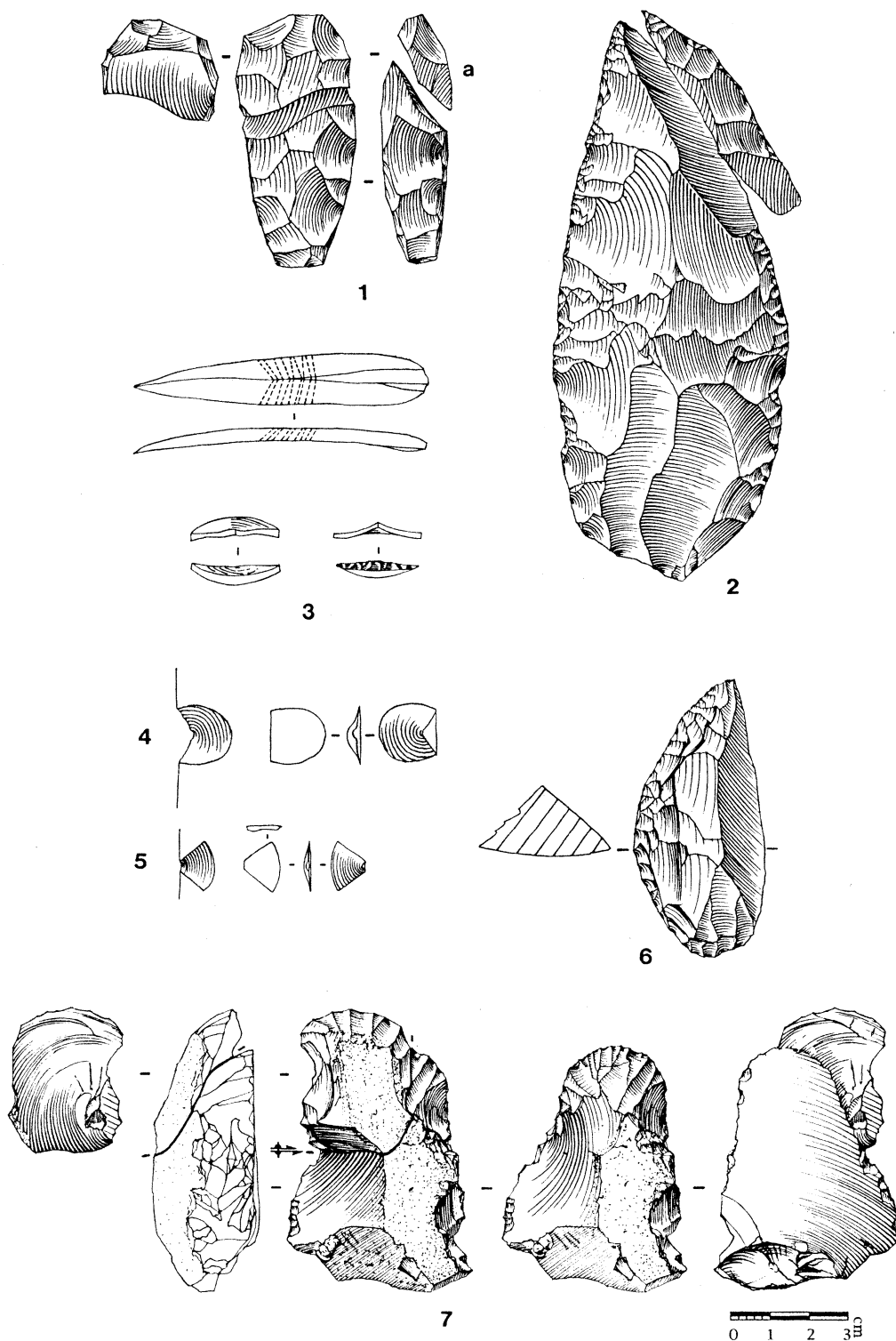

Fig. 34 — Various examples of special techniques. 1 : tranchet blow. 1a : resulting characteristic waste product. 2 : lateral tranchet blow on an Acheulean handaxe. 3 : successive Clactonian truncations (“obsidian side-blow blade-flaking”) on a pressure-flaked obsidian blade, and resulting waste products (Braidwood, 1961 : fig. 1). 4 : Clactonian notch technique and waste product. 5 : Quina retouch and resulting waste product. 6 : convex Quina sidescraper with scaled and stepped retouches. 7 : “carinated endscraper” type core, and conjoining Clactonian notch waste product (with a “Siret” accident); the notch reduces the width of the “front”, thus allowing further debitage; Aurignacian, Bergeracois flint, Corbiac-Vignoble 2, Dordogne.

The seven characteristics and associated descriptors

POSITION

direct
inverse
alternate
alternating
crossed
bifacial

LOCALIZATION

distal
mesial
proximal
right
left
basal

DISTRIBUTION

continuous
discontinuous
partial

DELINEATION

rectilinear
concave
convex
notched
denticulated
shoulder
cran
tongue
tang
long narrow tang
irregular
regular

EXTENT

short
long
invasive
covering

ANGLE

abrupt
crossed-abrupt
semi-abrupt
low

MORPHOLOGY

scaled
stepped
sub-parallel
parallel

Chapter 6

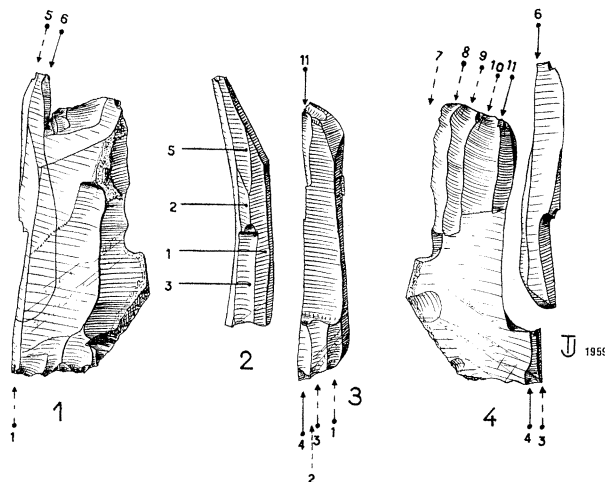

Technology as a means to an end

For an industry to be recognized and dealt with as such, the distinction between what is natural, what is accidental and what is intentional must in the first instance be clearly made. This of course does not imply that one should reject the first two in order to concentrate on the intentional. A stone artefact cannot be dissociated from its geological and archaeological context. All the events it bears the mark of (including those subsequent to its discard) are important for fitting both artefact and events into the network of data that we are trying to interpret. The significance of an artefact will be the greater for its showing mingled traces of geological and human actions; more than any other, a tool with multiple patinas will have an interesting history.

On some archaeological sites, the systematic re-use of tools from earlier levels to make new ones provokes thought not only as to the importance of certain blanks, but also as to whether a tool belongs to one archaeological level or another.

Reading a stone object

For the following reasons, it is necessary to go through the process of reading a stone object before attempting to study the lithic assemblage it belongs to. From the perspective of technological study, a stone object, be it a tool or a waste product, is part of a technical operation, all elements of which are interdependent. Moreover, in such a perspective, the reading of an object brings into play the raw material used, as well as the technical actions and the knowledge, which together work towards the conception of the tool, in the broader sense of the term (tool, weapon, tool component...). It is therefore essential to have an in-depth understanding of the basic document, in the present case each lithic object of an assemblage, in order to enrich subsequent inferences.

The term “object” is deliberately used, and applies to each and every element of a lithic assemblage; it also refers to any lump of rock that is assumed to have been handled or used by prehistoric people.

Various processes are involved in the study of a knapped object. For instance, in chapter 1, questions were broached that touched on the quality, abundance and form of raw materials, which condition the manufacture of the final tools. As detailed in the present chapter, the assessment of the type of blank (cobble, block, slab, flake, etc.) is actually sometimes included in the very process of studying the surface conditions of an object. Moreover, besides natural phenomena, knapping itself is liable to mask altogether the nature of the blank : such is the case with all entirely retouched bifacial pieces, from the handaxe to the arrowhead, as well as with cores that no longer possess a natural surface.

And last but not least, any attempt to decipher the *knapper's intentions* involves three successive steps in the reading of a stone artefact.

Initial perception, with a built-in hypothesis, is supplemented by a series of *observations*, which lead to a *biography* of the object.

Perception, in which sight plays a major role, and almost simultaneous overall identification, result in a global and sometimes syncretic recognition. The overall identification is all the more rapid if the observer has long experience and practises in the dialogue between prehistorian and knapped stone. It consists in an almost unconscious registering of countless visual images and tactile sensations, perceived in a fraction of a second : the outline, relief and colour, the play of light on the facets, the perception of the volume of the object, and the immediate registering of *technological traits* and their *sequence*.

The next step consists in checking the initial hypothesis. This entails deciphering the different marks according to their chronological order, in order to discover the successive intentions, whether successfully carried out or not.

A knapped stone is always a three dimensional object, which cannot be completely understood if it has not been examined from *every angle*, if it has not been *comprehensively read*. Such reading cannot be performed haphazardly in its observations and deductions; a set of rules orders their succession, and there can be only one such set for each category of object (bifacial piece, core, flake, etc.).

Take for instance a flake-tool.

Paradoxically enough, or so it seems, reading must begin with the recognition and study of the lower face and the bulb-and-butt part. If the latter is no longer present, the orientation of the flake can, in the last resort, be determined by taking into account the hackles (fig. 5), which are the only totally trustworthy clues. It is the “birth” of the blank that must be brought to light. Indeed, the reading of the *prior* technical events - debitage and traces of preparation on the core before the removal of the blank - can only be done in relation to the lower face.

Only then does reading involve the identification of retouching, of the events *subsequent* to the debitage of the blank; in this respect, the modification of the lower face (the fracture face) is the only indisputable proof that the piece has been “re-touched”. In complex cases, it is necessary to puzzle out the series of retouches, breaks, notches, burin blows, etc., according to their chronological sequence.

The last step corresponds to the mental reconstruction of the different events, of the different actions of the prehistoric knapper (or knappers in the case of pieces with a double patina) : on the core itself, during debitage, and after the removal of the blank. This chronological reconstruction, which takes into account the meaning of all the visible marks and the assumptions that some of them give rise to, will come into being through deduction, becoming the “history of the tool”.

It is a matter of convention that the tool subsequently receives a particular designation, either pseudo-functional (burin), morphological (laurel-leaf), geometrical (trapeze), geographical (Levallois), or anthroponymic (Krukowski), and that a number is attached to it for purposes of inventory or quantitative study. *However, the examination of the piece, the recognition of its technological significance, cannot be a matter of choice. It is immutable and remains the fundamental process.* It is therefore possible to speak of an objective reading, the process being identical for all observers.

1. Observation of surface conditions

Any reading of an object must begin with the careful examination of the surface condition(s), bearing in mind that :

- by the word “cortex” we understand a natural surface;
- by the word “patina” we understand an alteration of an intentionally worked (or used) surface;
- by the word “neocortex” we understand a surface of original cortex that has been altered by natural causes, such as fluvial transport. The presence of neocortex is therefore indicative of a secondary deposit of raw material.

Once the specimens showing only cortical surfaces have been set aside, technological analysis entails examining the entire appearance of a tool as it has come down to us. The indelible marks of its history must be deciphered according to their chronology.

Take the case of a core whose removal negatives have fresh arrises and ridges, others being blunted and striated as if by fluvial transport. Such a core carries several informations : it was first used as an “active” core, then rolled around, subsequently picked up (away from the point where it was found) and then flaked again before being discarded for good. There are even documented examples of tools having undergone three series of retouches, each showing a different patina.

Further sorting out may be necessary, in order to set aside “pseudo-tools”. Amongst others, these are most frequently pseudo-bifaces or “pebble-tools” fractured by frost or by a wide variation in temperature and humidity (the latter being common in desert settings); also, cobbles “knapped” by surf or glacial compression, and the (sometimes prehistoric) pieces crushed by cryoturbation or by mechanical devices (“denticulates”, “scrapers”, “racettes”, “borers”, etc.).

For any assemblage studied, it is therefore absolutely necessary to know the exact physical context of the site of origin :

- surface site;
- buried site;
- thickness and lithology of the archaeological layer;
- angle of dip;
- origin of the sediments (volcanic, metamorphic, sedimentary - aeolian or fluvial, glacial);
- cliff-base, talus slope, etc.

It should be kept in mind that, even in a living zone, trampling is far from negligible; it can become quite intense around springs where large animals have come to drink.

In all instances the accumulation of observations is essential.

2. Types of surface conditions

The following examples are intended simply as an indicative list.

2.1. Natural alterations

- *Cortex* is an integral part of the raw material in its natural condition, before being knapped. Its presence or absence on flakes provides information about the management and origin of the raw material.

- *Patina*, due to physical and chemical interactions, consists of a modification of the surface, which does not notably change its morphology. The degree of modification is eminently variable : it entails a change in colour - with or without modification of the granularity of the texture - either solely on the surface (film) or more deeply, sometimes throughout the body of the piece, which can then become considerably lighter. The causes are so numerous and varied (even within a single layer), and their study so complex that no chronological classification based on patina has yet been successfully developed, even when only one site is involved.

- *Wind gloss* is less glassy than that due to the swirling of sand in artesian springs. Both weathering phenomena can wear down an artefact to the point where its morphology is substantially modified, so that all traces of knapping may be obliterated.

- *Thermal damage* mainly covers : frost fractures, which can range from simple cracks to frost pits, or even to total fracture; variations in temperature combined with those of ambient humidity, giving more or less the same results (fig. 35); unintentional heat-altering, which produces “pot lid” fractures, crazed surfaces sometimes mimicking retouch on an edge, or clean fractures, accompanied by change of colour and lustre when the temperature exceeds 250°C. Such traces may be the only clues to accidental conflagrations or to ancient hearths.

2.2. Mechanical devices

Ranging from the plough to the bulldozer, present human activities cover ever larger surfaces, and affect ever deeper layers of the soil; lithic objects disfigured by mechanical contact with metal and often simulating retouch are therefore more and more common. Fortunately, such pieces are rarely free of specks or streaks of rust, and can also generally be detected owing to their multiple patinas.

2.3. Humanly induced alterations

Whether intentional or unintentional, heating can bring about the same visible alterations. There again, interpretation must rely on the chronological order of the facts : the systematic occurrence or high frequency of pieces altered by heating prior to retouching is strongly suggestive of heat treatment. However, there are documented examples of artefacts picked up (in the same way as tools with a double patina) after having been accidentally heat-altered because they happened to lie next to or under a hearth. Such artefacts can then have been used as cores or tool blanks.

Intentional heat-treating of siliceous rocks in order to improve pressure debitage or retouch can at present only be inferred from the greasy lustre visible only on the part retouched after thermal treatment (fig. 68).

Some alterations correspond to technical procedures : for instance, the blunting of the edge of a striking platform (see p. 131), the pecking or polishing of a pressure platform or of the debitage surface of a core, or even of the edge of a handaxe in the course of being shaped. The edge of a bifacial piece can also be deliberately blunted to prevent it from cutting, as is common in North America.

Other alterations can be classified together with traces of use, such as the glosses and polishes formed as a result of utilization, or the blunting of some Upper Palaeolithic burins.

2.4. Additions

One must keep in mind that wood, resin, bitumen, leather and pigments, while not always visible, can be detected and analysed by means of microsampling (fig. 51). On the other hand, such elements may have resisted long enough for a double patina to develop, as in the case of some hafted implements.

One should therefore proceed with caution when washing the pieces and applying varnish in the course of marking.

To conclude, there are unlimited possible combinations of such modifications, alterations and additions. The importance and complexity of surface conditions, often impossible to unravel during field-work, require minute observation during the laboratory phase, as well as extreme caution in dealing with archaeological material during and immediately after excavation. Blunders can irretrievably jeopardize certain observations and characterizations, particularly those concerning additions.

3. Framework for the reading of a knapped stone object

3.1. Observation of surface conditions

3.2. Characterization of the raw material

3.3. Identification of the blank, if recognizable

Unknapped blank

- type (slab, cobble, etc.)
- orientation (according to a morphological axis, to technical characteristics, etc.)

Knapped blank

- orientation according to the debitage axis (lower face, upper face, butt, left and right edges, etc.)
- appreciation of technical morphologies (including knapping accidents)
 - which tell us about knapping techniques and methods
 - by examining the proximal end : pressure and percussion techniques
 - by examining the upper face : not predetermined, predetermined by means of the Levallois method, the Kombewa method, etc.
 - by examining the distal end : plunging on a core, on a burin, etc.
 - by examining breaks : accidental or intentional, occurring during debitage, etc.
 - which testify to preparation
 - by examining the upper face : Levallois surface, crest, etc.
 - by examining the lower face : different butt types, overhang abrasion, etc.

3.4. Special knapping techniques

3.5. Description of removals by means of their main characteristics

- position
- localization
- distribution
- delineation
- extent
- angle
- morphology
- etc.

3.6. Defining the object, whether it be a tool or not

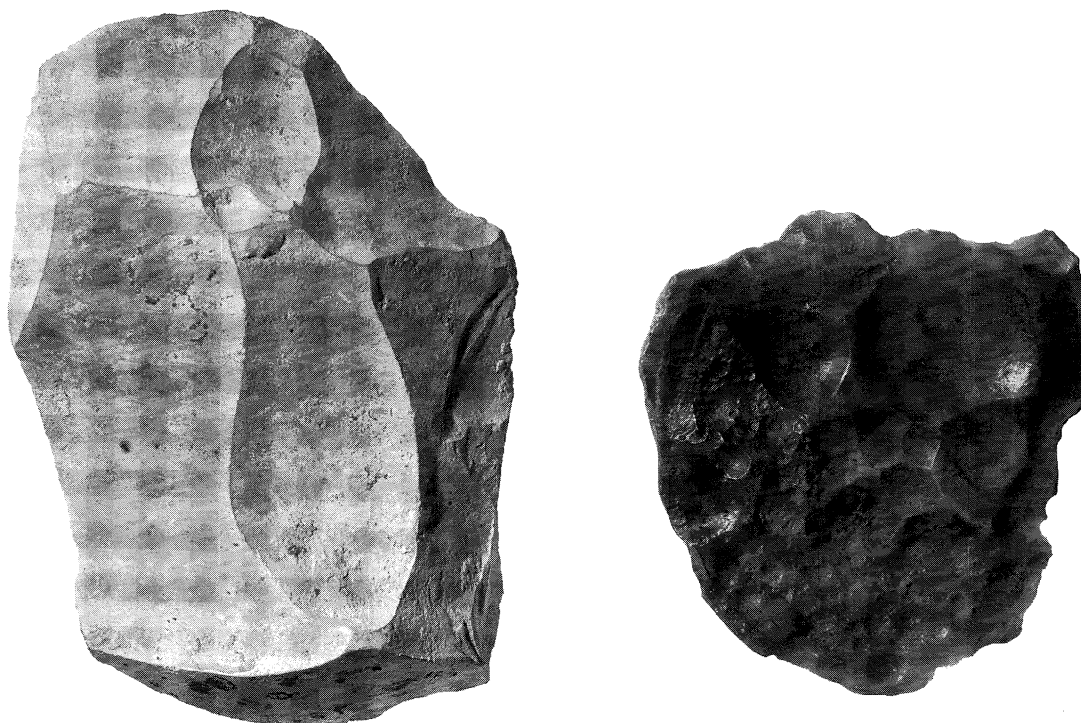

Fig. 35 — Thermal damage : natural pits mimicking removal negatives, siliceous rock, Qatar desert (Photo J.-L. Princelle).

Understanding a lithic assemblage

The intrinsic informative value of an archaeological site, the quality of excavation and recording methods, the amount of lithic material and the type of site (short-term location, seasonal or permanent campsite, workshop, etc.), will all have a bearing on possible interpretations. However, the mastery of technological interpretation, due to the development of new analytical methods and techniques, has considerably enriched the study of prehistoric societies. Innovative research strategies give substance to hypotheses long considered as purely speculative : *conjoining and refitting*, *experimentation* and *microwear analysis* have witnessed major breakthroughs over the last ten years. The study of the *cognitive and psychomotor aspects of technical behaviour* is a recent development, but its potential for research into the technical skills of extinct societies has already been demonstrated. These methods, which have now become fields of specialization, are briefly presented hereafter.

1. Conjoins and refits (figs. 36 and 40)

Beginning nearly a century ago, conjoining - rather than refitting - has been common practice among prehistorians, generally in order to confirm the contemporaneity of a stratigraphic sequence, or simply out of curiosity⁸³.

At Pincevent⁸⁴, the systematic refitting of finds, by which the understanding of the occupation units was furthered, has shown the wealth of information that such a method can provide. At present, it contributes more to palaeoethnic knowledge than to research into knapping

83 *The Big Puzzle*, 1980; Cahen, 1987.

84 Leroi-Gourhan, Brézillon, 1972.

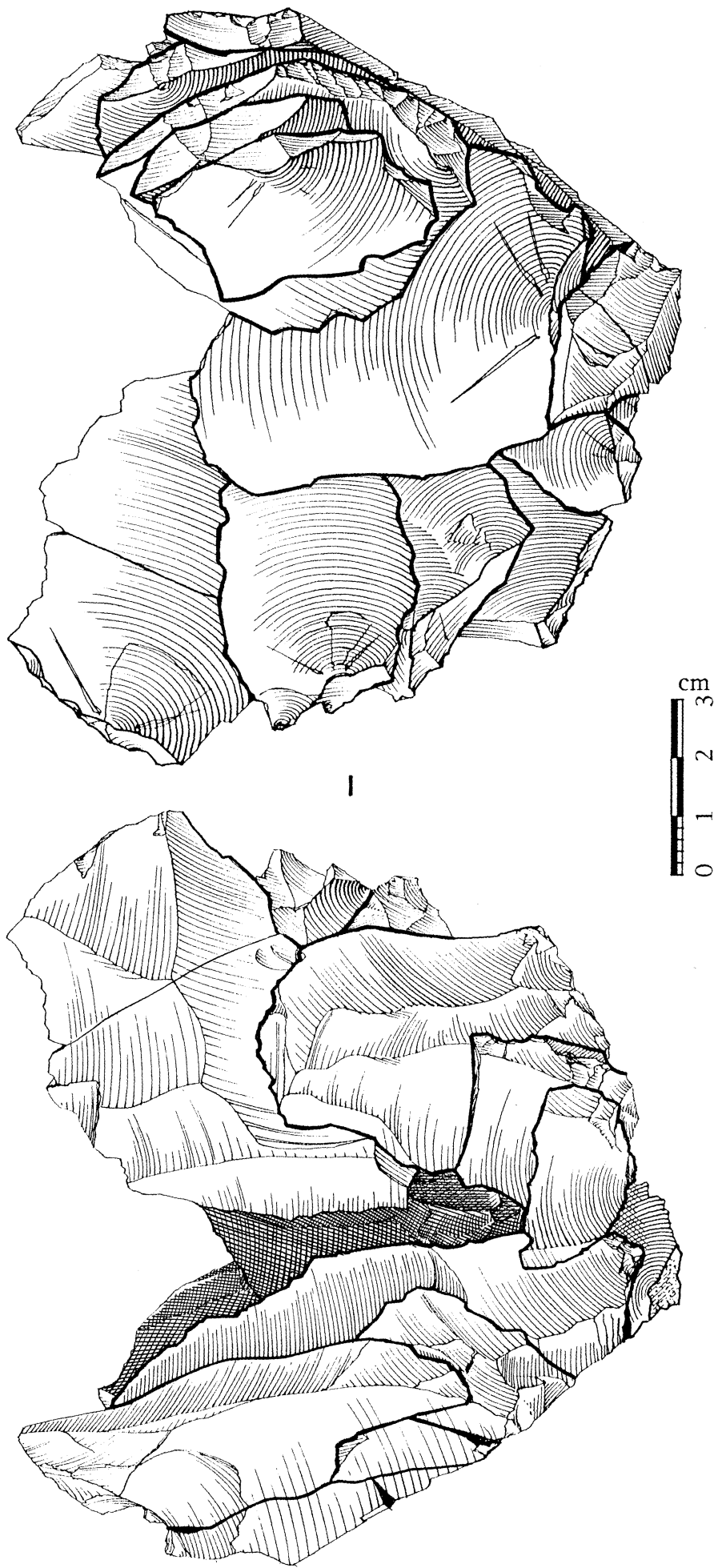

Fig. 36 — Refitting. Centripetal Levallois debitage : at least five Levallois flakes were produced, one of which was retouched into a scraper. Mousterian, flint, Bérigoutte, Vaucluse (Brugal *et al.*, 1994).

techniques and methods, which can be inferred from knapping products⁸⁵. At Meer II⁸⁶, in the absence of preserved living floors, it is owing to the numerous refits that the spatial organization of the campsite was finally understood. Refitting, now almost systematically practised, is essential to the deciphering of surface sites in particular⁸⁷.

Thanks to this method, J. Tixier was able to demonstrate the unity of a large Neolithic surface settlement in a desert setting, at Bordj Mellala (Algeria), which at first sight could have been considered as a juxtaposition of distinct sites. By plotting objects on a plan, carrying out refits of ostrich eggs and lithics, and subsequently analysing the spatial patterning of the refits, he showed that the "sites" actually represented different activity areas within a single occupation⁸⁸.

Recently, this method allowed socio-economic inferences to be made concerning two Magdalenian occupation units at Etiolles in the Paris Basin⁸⁹, after confirmation that they were indeed contemporary. A step was thus taken, which makes it possible, through the unravelling of intentions, to propose a type of social organization in an Upper Palaeolithic culture.

Refits are also necessary to answer such questions as :

- is there a relationship between particular cores and particular types of tools ?
- were tools (or tool blanks) knapped in advance, or as needed ?

The other contributions of this method are mainly verifications :

- what debitage or retouching operations were carried out on the actual site ?
- what is the relationship between the categories of debitage products associated with the different stages of the knapping process (roughing out, shaping out, initial / optimal / final phase of debitage), and the types of tools ? In other words, what - in terms of the differential management of debitage products - is the aim of each operation ? Because the morphology of the blanks has often been severely modified by retouch, it is not easy to answer the question without resorting to conjoining and refitting ;

- was the transformation, resharpening and re-use of broken pieces a common phenomenon ? Was this done randomly or systematically ? Depending on the amount of raw material available, was it used sparingly or not ? Such riddles can be solved by conjoining several tools, or tools and their characteristic waste products, by matching fragments of a single blank, by fitting a blank on another blank or on a core ;

- how many blocks were needed to produce the tools, and which items were brought to the campsite as finished end-products ? It can turn out (and this is only discovered through refitting) that two types of rocks, which appear to differ in colour, grain or patina, actually come from the same block.

Conjoining and refitting are time-consuming procedures, which require an in-depth knowledge of knapping techniques ; the meticulous observation involved also guarantees a more accurate reading of lithics.

The many results achieved through systematic refitting over the last few years have highlighted the relevance and potential of the method, which must be applied within the context of well defined research strategies and to appropriate archaeological sites.

2. Knapping experiments

The experimental knapping of hard rocks should not be undertaken for the purpose of "reproducing" aesthetically pleasing prehistoric objects for exhibition or sale. We are not dealing here with "replication" but with a scientific approach, and our concern is not copying but understanding.

Experimental knapping is an analogic process, which has the advantage of showing an affinity with test experiments. Indeed, it seemed possible a few years ago to repeat an experiment as often as necessary⁹⁰, while changing a single parameter, such as the position, the motion, the

85 Cahen *et al.*, 1980.

86 Van Noten *et al.*, 1978.

87 Audouze, Cahen, 1982.

88 Tixier *et al.*, 1976b.

89 Pigeot, 1987 ; Olive, 1988.

90 Tixier, Inizan, Roche, 1980.

hammer, the stability of the core or blank, etc., thereby fulfilling the conditions for a statistical exploitation of the results. We thus imagined that plausibility could be reached by accumulating the assumptions by which a possibility can be validated. In actual fact, parameters have proved so numerous and so “fluctuating” that the statistical exploitation of experiments has almost been given up.

Experimentation should always be carried out in the light of archaeological information. It can only bring us nearer to the prehistoric knapper without actually reaching him, because the motivations are different. Nevertheless, although it is impossible to assess the exact relationship between prehistoric people and their artefacts, even where *Homo sapiens fossilis* is concerned, it is incontrovertible that prehistory can never again disregard experimental knapping, the main objectives of which are presented hereafter.

The destruction of myths

For instance, Acheulean man stubbornly fashioning his tools or weapons for hours on end. As a matter of fact, it only takes about a quarter of an hour to shape a handaxe using a soft hammer, and only a few seconds to retouch a scraper.

The testing of raw materials

When raw materials have been sourced, it is important to test them (or have them tested) in order to answer a few preliminary questions. This is essential to the study of a lithic assemblage, insofar as a material should never be deemed “suitable” or “unsuitable” for knapping before it has been worked.

In the case of a given type of rock (fig. 2) :

- could the prehistoric knappers have produced more or better quality artefacts?
- could they have manufactured much larger or much smaller tools (considering the dimensions and quality of the rock)?
- what were the limits of the possible techniques and methods?
- what were the physical properties of the rock?

Such questions will only be mildly relevant in the case of sites yielding large quantities of fine tools manufactured on high-grade local raw material, but much more so when the assemblages seem rather crude. Before passing judgment on the skill or “archaism” of the prehistoric knappers, it is essential to test the materials in order to appreciate their genuine suitability for knapping in relation to the various techniques applied. Thus, the extraction of blades proves difficult on some quartzites (such as the silicified arenites of Brazil), and it is not easy to avoid breaking thin blades during debitage. There is no way that even an experienced stone-knapper could tell this at first sight. Some Japanese sanukites also illustrate this point. These rocks are very easy to knap, but absolutely not suitable for systematic blade debitage. The development of an original method for the production of certain elongated tools necessarily ensued. The Japanese Upper Palaeolithic Setouchi knives with backed edges⁹¹ were thus often manufactured from flakes that were intentionally more broad than long. These were removed, one above the other, from a convex lower flake-surface (the first therefore being a Kombewa flake, see p. 68).

The rediscovery of bygone methods and techniques

An accurate assessment of techniques is vital, especially where innovations are concerned.

The reliability of an assessment depends on experimental tests, and if it finally proves impossible to identify the technique used, one can at least define some limits (which may subsequently be challenged) : it is already possible to distinguish the application of pressure from the use of a punch by highlighting significant characteristics.

Reliability will also depend on the amount of archaeological material : a larger sample will allow a wider range of observations to be made. Any credible assessment must nevertheless

91 Akazawa *et al.*, 1980.

be the work of an experienced specialist. Knapping skills cannot be acquired in the space of a few months, the learning process is very slow, and as in many disciplines it takes several years to become an expert. Our knowledge is yet far from being comprehensive :

- we are still unable to reproduce the very long Magdalenian flint blades (up to 60 cm) of the Ile-de-France, or the obsidian blades recovered from Aztec tombs ;
- the debitage of blades by direct percussion with a hammerstone is only now beginning to be seriously tested⁹² (p. 74);
- there are yet very few publications mentioning the use of the lever and all its variants⁹³ (p. 32).

Moreover, it is clear that breakthroughs occur when several experimenters focus on the same precise problem : we now know how to channel-flake a Folsom point using direct percussion, indirect percussion and pressure⁹⁴.

By combining the experimental approach with the study of the *chaînes opératoires* of a lithic assemblage, we are able to reconstruct very precisely the knapping schemes of prehistoric craftsmen, thereby defining the various methods used.

The transmission of knowledge

Beginners will progress rapidly if taught the fundamentals of lithic technology by an experimenter.

Another aim of experimentation is to reveal intentions. This includes :

- distinguishing what is accidental from what is intentional ;
- distinguishing what is easy from what is difficult ; an Acheulean handaxe is easier to manufacture than a Levallois point ;
- distinguishing traces of preparation from traces of use. Efficient debitage using a wooden or bone hammer involves an abrasion of the edge of a core's striking or pressure platform in order to suppress the overhang formed by the negative bulbs of previous removals, especially in the case of blade debitage. This abrasion (friction with a pebble) always leaves traces and sometimes causes extreme blunting ;
- distinguishing preparation removals from retouches. A prepared burin spall, whose lower face is intact, unmodified by retouch, is a characteristic waste product, whereas a backed bladelet, whose lower face has necessarily been modified by retouch, is a tool.
- highlighting the fact that the shaping out of the core, its immobilization, and all the preparations involved by pressure debitage require far more sophisticated skills than the debitage itself.

Experimentation, whether practised by prehistorians or carried out within the context of ethnoarcheological research programs, has great potential : it can help us to assess the technical skills of prehistoric people, to gauge their performances and judge their degree of competence.

3. Traces of use

The systematic and rational study of detectable use-wear over the whole surface of stone tools has already proven itself, and goes far beyond research into the function of such tools. There are now many specialists in this branch of research, the foundations of which were laid in the USSR by S.A. Semenov in 1930. Semenov's work, which was translated into English in 1964⁹⁵, showed that it was possible to determine tool function in prehistory, a matter that had until then remained in the realm of speculation. "The credit will go to Semenov for having made systematic observations and for having developed the necessary techniques of study. His work, *Prehistoric Technology*, will long remain a reference book"⁹⁶.

92 Pelegrin, 1991a.

93 Volkof, Guirria, 1991.

94 Crabtree, 1966.

95 Semenov, 1964.

96 Bordes, 1967 : 37.

Only the major milestones in the constitution of this new discipline need to be mentioned : the first symposium on the subject was held in Vancouver in 1977⁹⁷, followed in 1980 by Keeley's synthesis⁹⁸, the first comprehensive piece of work since Semenov's.

Research within the discipline concerns all prehistoric periods, even though convincing results pertaining to the more ancient ones are at present difficult to obtain⁹⁹.

The study of wear traces requires an understanding of the rock types used to make tools, as well as of the contact substances. This knowledge is acquired through the sustained practise of experimentation. It is by systematically alternating archaeological observation and experimental study that one succeeds in understanding the different stages of tool manufacture and use (hafting, use pattern, sharpening, etc.). The technical approach varies according to the archaeological question and may involve different optical instruments, such as stereoscopic microscopes, metallographic microscopes, or scanning electron microscopes.

In their current form, microwear studies pertain to different research designs.

Either they try to answer a number of questions, such as :

- what material was processed with the tool ?
- what was the duration of the work ?
- what type of movement was performed ?
- was the tool hafted ?

The aim is thus essentially to explain how a tool was used, or to compare the results with typological data.

Alternatively, such studies focus on the origin, the cause, of wear traces, thus proving efficient for defining the very concept of what a tool is. Indeed, by allowing the reconstruction of composite tools, microwear studies have cast light on the problem of hafting.

The study of wear traces also contributes to the detection of natural alterations.

However, one should bear in mind that a result valid for a single site cannot be considered universally valid without verification.

Microwear studies are now incorporated into all palaeoethnically oriented research, since it is often the only way to confirm hypotheses about domestic, economic, or artistic activities. The agricultural realm¹⁰⁰ certainly contributed the most to enrich possible interpretations, thanks to the combined studies of wear traces, knapping techniques (pertaining to the choice of blanks), paleobotany and archeozoology.

4. Technical behaviour

Technological analysis is proving a most fruitful approach for deciphering lithic assemblages in terms of technical activities to begin with, and then in terms of technical behaviour through the assessment of motor dexterities and cognitive capacities.

4.1. Assessment

The assessment of motor dexterities and cognitive capacities is a fundamental process, because any interpretation depends upon it for its significance and credibility. It can always be undertaken, whatever cultures and human types are concerned, because it is based on lithic production, as it is possible to assess prehistoric people's subsistence strategies by examining the faunal remains from archaeological sites. It depends however both on the quality of the excavations and on that of the recovered material, and also to a great extent on the type of site : there will be little to say about a short-term hunting camp containing only a small assemblage, but far more about a knapping workshop where several *chaînes opératoires* may be represented¹⁰¹. This type of work can nevertheless be carried out on old museum collections, provided the information concerning the context of finds is sufficient.

97 Lithic Use-wear Analysis, 1979.

98 Keeley, 1980.

99 Beyries 1993.

100 Anderson, 1992.

101 Karlin, Ploux, 1994.

As we expounded in the introduction, the transformation of a block of stone for the purpose of obtaining one or more tools requires both a *project* and the ability to implement it. According to J. Pelegrin¹⁰², a stone-knapper's reasoning involves thinking out a sequence of cognitive and sensorimotor operations, and the different stages in the implementation of the project can be outlined thus : perception of the task to carry out, followed by the choice of the "ideal" solution amongst all the known possibilities (the mental representation of the artefact). At this stage, the *conceptual scheme* is worked out, and the operations necessary to its completion are devised. The knapper then follows an *operative knapping scheme* (the sequence of technical operations), applying all his *skill* (competence born of experience, of sustained practice) and *knowledge* to complete his project with a varying degree of *dexterity*. A poorly executed operative scheme can be saved by technical tricks derived from the knapper's skills; conversely, a clumsy slip of the hand can be corrected by a good conceptual knowledge of possible recovery procedures. It is through the unravelling of operative knapping schemes that inferences can be made concerning the degree of skill, the quality of the performance and the intelligence of the knapper.

The analysis of *chaînes opératoires* in terms of psychomotor processes shows that it is possible to go beyond the identification of technical actions, possible to highlight, for each stage of the *chaîne opératoire*, the choices, constraints and preferences of the knapper, the reasons for his success or failure, possible to see through what operations each project is implemented. This necessarily requires an appraisal based on criteria established by an experimenter and, if possible, on refits.

4.2. Interpretation

New lines of research for the interpretation of prehistoric knappers' competences have developed with the advent of a "cognitive archaeology".

However, interpretations of technical behaviour are only conceivable for past *Homo sapiens sapiens*, because he is assumed to have had the same cognitive and motor abilities as modern man. It would be dangerous to extend this assumption to "pre-sapiens" species, whose competences can only be assessed through the study of lithic material¹⁰³. Nevertheless, primatology and ethology have recently focused on the technical patterns of behaviour of non-human primates (chimpanzees in particular¹⁰⁴), and the results have contributed to a renewal in the studies concerned with this particular branch of prehistory. The need for such analogy-based approaches increases as interest shifts to earlier periods.

Archaeology as a whole, and prehistory in particular, has been very receptive to the cognitive sciences¹⁰⁵; this comes as no surprise, since archaeology is based on the study of material culture, on the analysis of artefacts, which are the products of human intelligence. The discipline can only be enriched by attempts to lay bare, to understand, the psychological and motor mechanisms that subtend these productions.

How was the technical knowledge relative to stone-knapping transmitted? What learning processes were involved¹⁰⁶? Is it possible to detect personal specificities¹⁰⁷? Such are some of the questions that a cognitive approach - of which the concept of *chaîne opératoire* is an integral part - now enables us to consider. Prehistory has gained a vast research area, yet little explored and sometimes speculative, but so far no regularities can be derived from results that remain very context-bound. Some themes are particularly promising. For instance, the investigation into learning processes, through an appraisal of the difficulty with which skills can be mastered, leads directly to the analysis of such major phenomena as specialization, innovation and borrowing, three notions that illustrate the social importance of techniques.

102 Pelegrin, 1991b, 1995.

103 Roche, Texier, 1996.

104 Joulain, 1994.

105 There is a wealth of literature on this subject. Major references can be found in Gibson, Ingold (eds), 1993 and Renfrew, Zubrow (eds), 1994.

106 Roux, 1991; Karlin, Julien, 1994; Roux, Bril, Dietrich, 1995.

107 Ploux, 1989.

Chapter 7

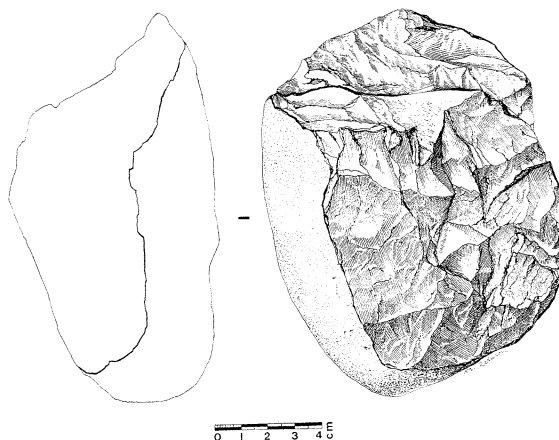

Graphic representation

Scientific illustration is a hybrid between art and science, which follows an iconographic tradition derived from the Golden Age of the Natural Sciences.

Far from being simply a picture, the aim of artefact illustration is to use two-dimensional images to provide an intelligible description of a three-dimensional object. By combining direct graphical representation with symbolic conventions we obtain an excellent means of communication – a universal language, which not only enriches textual description but may be the only source of information for foreign language publications.

Graphical representation of prehistoric industries, as used in this volume, models technological rules in order to show both the morphology of each object (tool, waste product, etc.) and its place in the *chaîne opératoire*. It must use graphical methods to present the sequence of chronological actions, which can be read from the characteristic marks remaining on the object. Developments in reading technological steps has led to new graphical methods : multiple views, new symbols, schematic representation, etc.

Finally, drawing and photography are distinct methods of expression, appropriate to specific objectives. They provide complementary methods of representation, which can be used to enrich the illustration of a publication.

Planning

1. What to draw

It is rarely possible to draw every artefact from a site. Since quantity is no guarantee of quality, this handicap can be turned to advantage. The items to be drawn must be selected following the number of illustrations that can be included in the publication¹⁰⁸. The aim is to present as much information as possible with a minimum number of illustrations. Prehistorian and illustrator must therefore work together to make the choice of objects that will best represent the results of the study. Choosing the “best” objects does not provide a representative view of the collection.

108 Prodhomme, 1987.

2. How to draw

Computers provide a new drawing tool to add to numerous existing tools (charcoal crayon, soft lead pencil, ink, watercolour...). How useful is this new tool for illustrations of prehistoric material?

Although still little used, computer-aided design offers a wide range of capabilities : high-end illustration software will generate any variety of solid or broken line; scanned images can be modified down to the pixel level; laser printers can generate images of impeccable quality; computer-aided illustration allows anyone to produce graphics without the need to master normal techniques. However, computers remain a drawing tool like any other : even though they allow anyone to produce a picture, they can never substitute for the technological reading of an object, which is the indispensable basis for an effective drawing.

In this volume we therefore describe a traditional graphic technique, using pencil and Indian ink¹⁰⁹.

Drawing

1. General principles

They are organized according to the layout of the book.

- Shaping (fig. 37)

When drawing a shaped object, the drawing must show the sequence of flaking actions required to generate the three-dimensional shape of the object. Bifacial objects should normally be drawn from both sides, while multifacial, polyhedral, spheroidal, etc. objects should normally be shown using multiple views. Hackles and negative bulbs should be carefully recorded on these views. For bifacial pieces, the profile should show the symmetry or dissymmetry of the object. Judiciously chosen sections can be used to show the three-dimensional shape achieved by the knapper. Schematic diagrams can be used to show the shaping methods used.

- Flaking (fig. 39)

Although cores provide the most information, their illustration is often limited to a single view of the debitage surfaces. It is essential to show the shaping out of the volume of the core and the preparations for flake or blade removal, through :

- views of the debitage surfaces ;
- views of the shaping out surfaces ;
- views of the striking platforms and any preparation.

Schematic representations can be used to illustrate progressive steps in the exploitation of a core.

Drawings of debitage products should show the morphology of the object together with removals that preceded its detachment (fig. 38). From the drawing, one should be able to partly identify the core from which the object was derived. The butt must be figured, because it often shows distinctive features, which allow the discrimination of different flaking techniques. Bulb scars, ripples and the morphology of the bulb are often good indicators of flaking techniques, and should always be illustrated.

The diacritic diagram is used to synthesize the sequence of technical steps (see p. 126).

- Retouching

Removals can be accidental, deliberately made by the knapper, or can result from use. They should be illustrated precisely, clearly recording morphological differences without making assumptions about their origin. Supplementing descriptive views, sections can be drawn through retouched areas to show modifications to edge angle or specific morphology as in the case, for instance, of Quina retouch (fig. 34 : 5).

¹⁰⁹ Coineau, 1978.

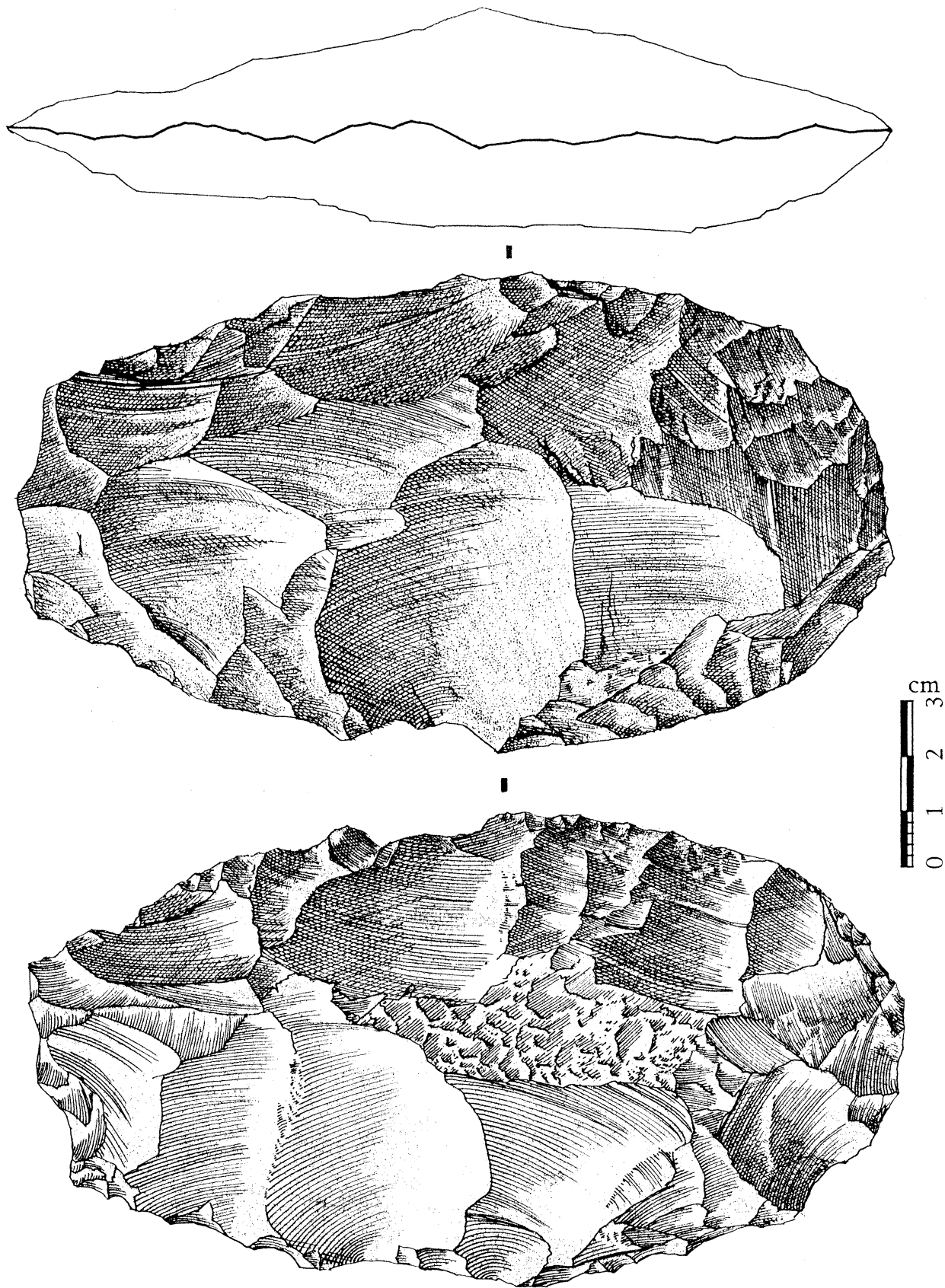

Fig. 37 — Acheulean handaxe, welded tuff, Isenya, Kenya.

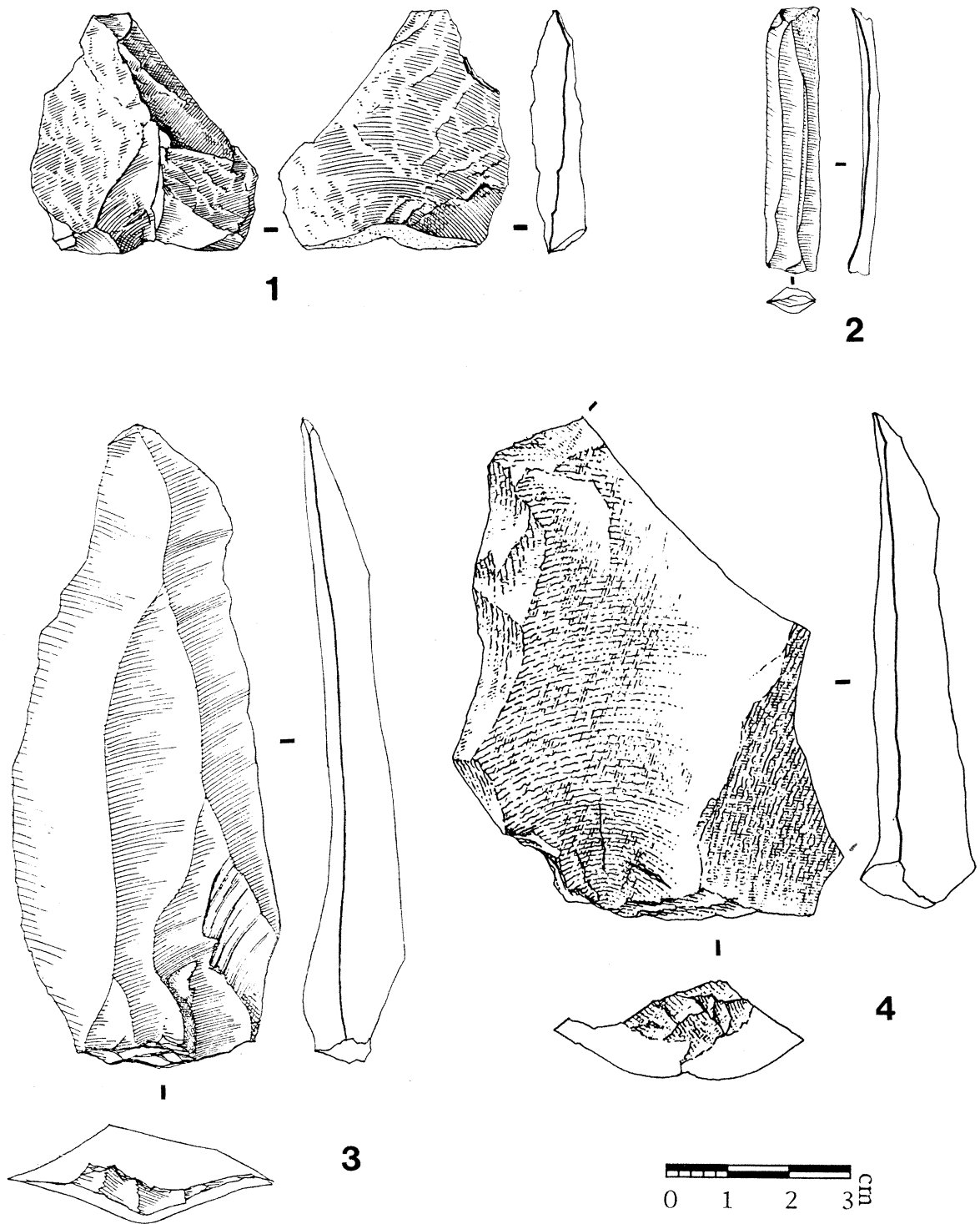

Fig. 38 — Various examples of debitage products. 1 : trachyte flake, pre-Oldowan, West Turkana, Kenya. 2 : flint bladelet, Caspian, Le Relilai, Algeria. 3 : flint elongated flake, Mousterian, Bérigoule, Vaucluse. 4 : phonolite flake, Acheulean, Isenya, Kenya.

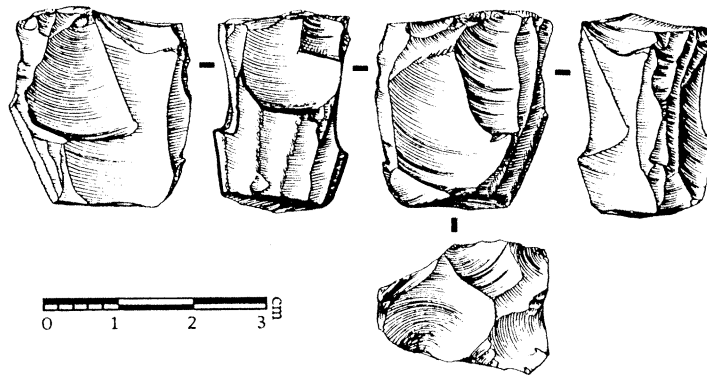

Fig. 39 — Pressure-flaked bladelet-core, subsequently percussion-flaked, Capsian, Aïn Dokkara, Algeria (Tixier, 1976a : fig. 2, 2).

- Refits (figs. 36 and 40)

Refit diagrams are difficult to interpret and orthogonal views must be abandoned, as the reader will have trouble bringing together several complex views in a three-dimensional space. It is therefore best to limit the number of views by choosing a general view, which gives as much information as possible. Starting from this general view one can pull out a couple of detail views, which provide a better interpretation of the knapping sequence. Numbered arrows can be used to show the order of flake removals. The three-dimensional shape of the refitted object is shown as a unit rather than through drawing each component individually.

2. Layout conventions

Any description of an object, whatever it be, is based on its orientation (fig. 41). Whether the edge is a left edge or a right edge depends on which way round the artefact is placed. As research has progressed, a common graphical language has developed, specifying conventions for the orientation of artefacts, which are not necessarily always logical. Consistent rules must be used throughout a publication, and the rules should be stated.

There are five situations to be considered.

- Cores

Flake cores are oriented according to the debitage axis of the last flake removed (fig. 21). If the last removal cannot be identified; the core is oriented according to its morphology.

Blade cores, whether flaked by percussion or by pressure, are oriented with the striking platform upwards. When there are several striking platforms, the last-used platform is oriented upwards (fig. 29 : 2).

- Unretouched or retouched debitage products

These include flakes (*lato sensu*) and tools on an unretouched flake (*e.g.* Levallois point).

They are oriented according to their debitage axis, proximal end downwards, and upper face towards the viewer. The debitage axis is the straight line that defines the progression of the fracture front across the lower face as the flake is detached. It starts from the impact point and divides the bulb into two equal parts (fig. 41 : 1).

- Tools such as scrapers, piercers, burins, etc., whatever the type of blank used.

These artefacts are oriented with the supposed active part upwards (scraper edge, piercer point, burin tip, etc.). If this orientation does not correspond with the debitage axis of the object, the latter is indicated by a symbol on the upper face view (fig. 58 : 9).

- Shaped tools (bifacial pieces, preforms, trihedrons, polyhedrons, etc.).

These artefacts are oriented according to their morphological axis (fig. 41 : 2, figs. 12 and 13), even if the original blank is a flake. The morphological axis is the axis of greatest symmetry, in the sense of its greatest length (fig. 41 : 1).

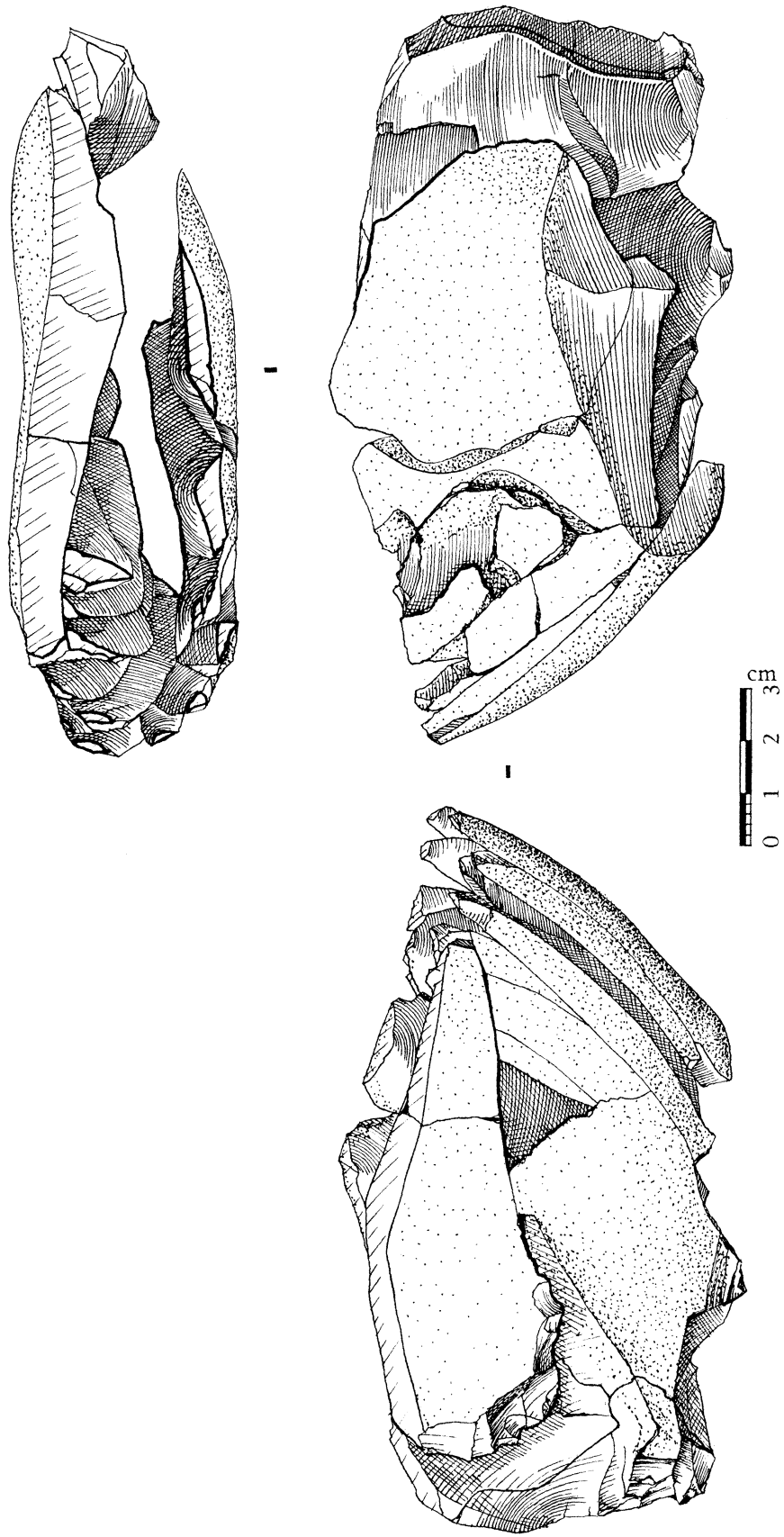

Fig. 40 — Refitting. Flakes belonging to the shaping out phase and to the initial phase of blade debitage. The core is missing. Ahmarian, flint, Abu Noshra II, Egypt (Phillips, 1991 : fig. 7).

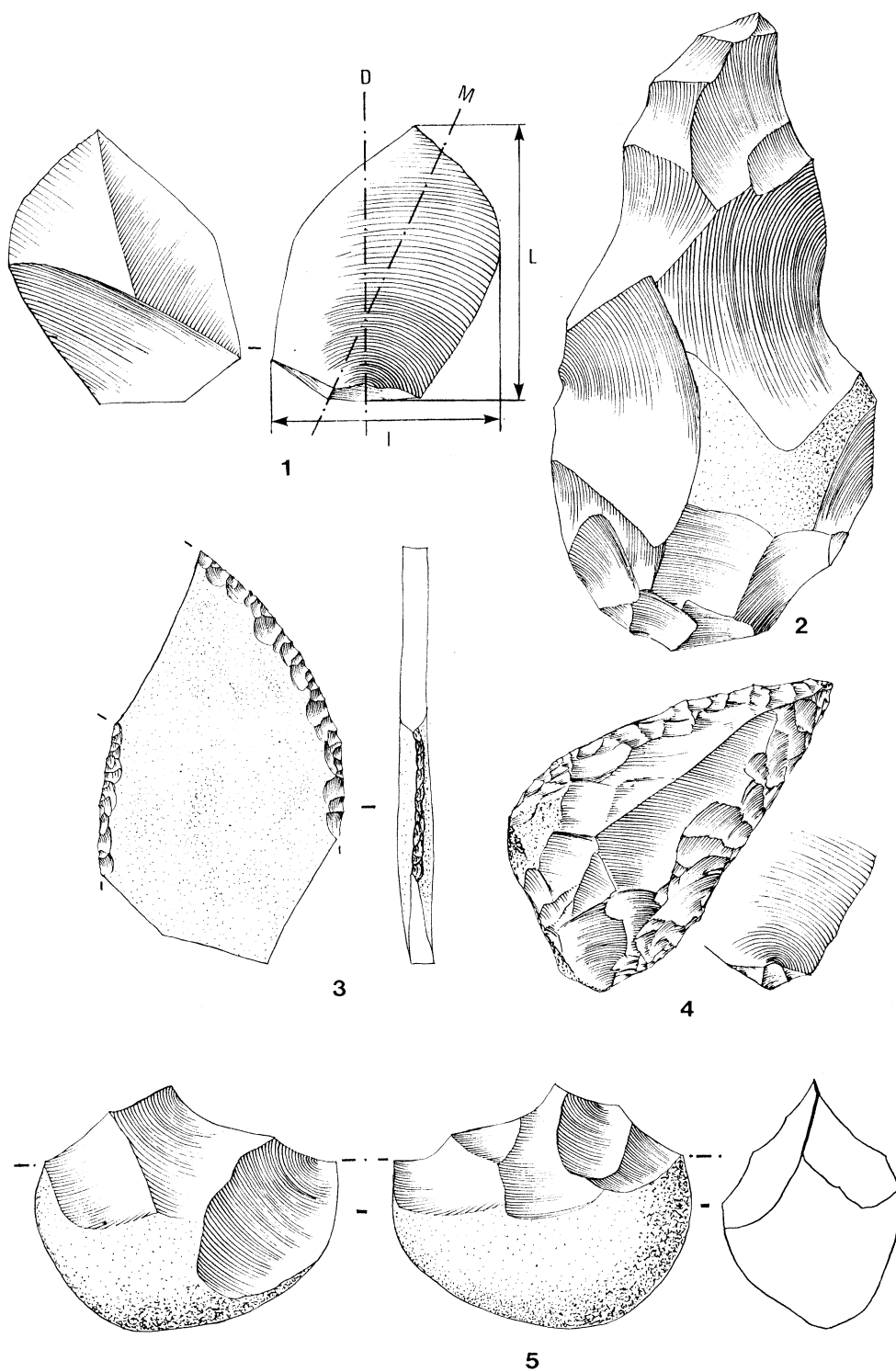

Fig. 41 — Examples of orientation. 1 : according to the debitage axis (D) of a flake (M being the morphological axis). 2 : according to the morphological axis of a handaxe. 3 : according to the morphological axis of a sidescraper made on a slab. 4 : according to the debitage axis of a convergent sidescraper; when this is different from the morphological axis, the tool is known as a *déjeté* sidescraper. 5 : according to the edge and the knapped surface of a chopper.

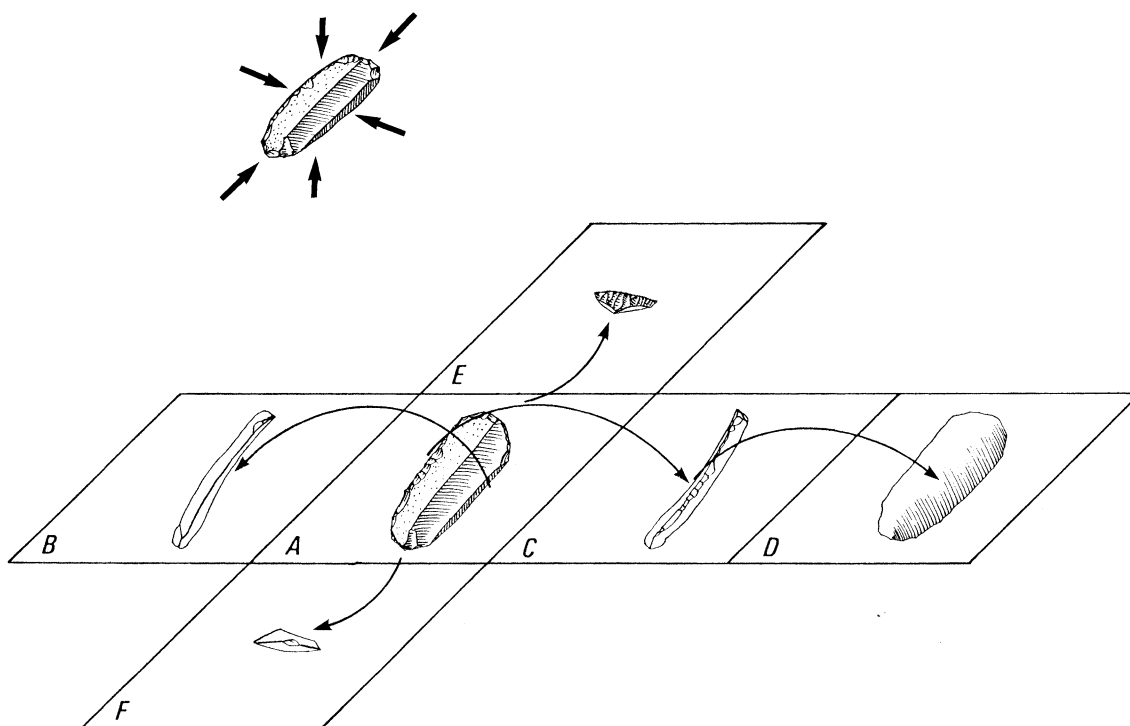

Fig. 42 — Views used in lithic illustration (French system).

Polyhedrons and spheroids are oriented according to the debitage axis of the last flake removed. If this can not be determined, they can be oriented as the illustrator thinks best (fig. 16 : 1 and 2).

- Tools on a natural blank

These include tools on slabs (fig. 41 : 3), on pebbles (fig. 41 : 5), on blocks, on frost flakes (fig. 50). They are most commonly oriented according to their morphological axis.

3. Description of the object

3.1. Views

The system used was developed by anthropologists for drawing human skulls. In this system, the views are designated as follows :

- *norma frontalis* for the front view ;
- *norma occipitalis* for the rear view ;
- *norma lateralis (sinistra and dextra)* for the left and right lateral views ;
- *norma verticalis* and *norma basilaris* for the top and bottom views.

This system allows the description of a three-dimensional object by a series of two-dimensional images. These images give separate views of each side of the object, supplemented by sections or section views if required.

The conventional method of deriving the different views of an object uses orthogonal projection onto each of the faces of an enclosing block. Each successive view is obtained by rotating the object 90° from the principal view.

Six views are therefore sufficient to fully describe the surface of any three-dimensional object (fig. 42), but this number is rarely needed to represent a lithic artefact. It is sufficient to select appropriate views for the adequate comprehension of the object.

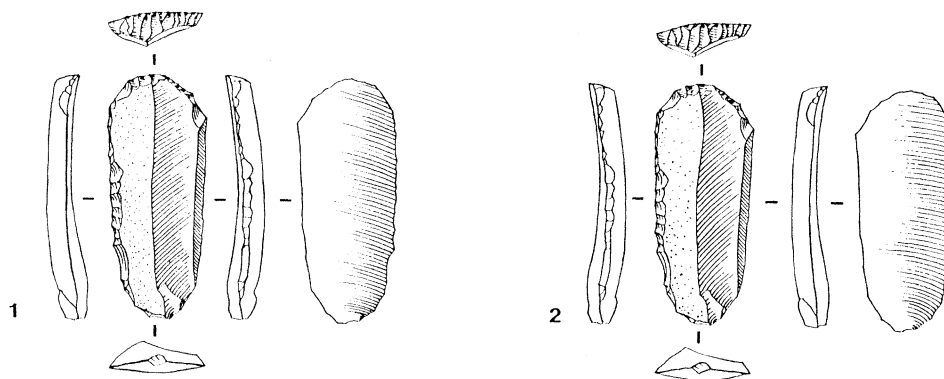

Fig. 43 — Two layouts of views. 1: French system. 2: American system.

The views used in lithic illustration carry names derived from the vocabulary of both lithic technology and drawing.

- View A: this is the principal view. With rare exceptions it is not adequate to fully describe an object, although it is often the only one provided. It is known as front view, surface A and upper face view for debitage products.

- View B: view of the object from the right. It is rendered on the left and known as right view, side view, profile view or right profile. It shows the thickness, convexity and volumetric balance of the object, the rectilinear, curved or twisted nature of the profile and the longitudinal symmetry or dissymmetry.

- View C: view of the object from the left. It is rendered on the right and known as left view, side view, profile view or left profile. This view performs the same role as view B. Choice of one over the other depends on the features one wishes to show.

- View D: view of the opposite surface from view A, known as back view, surface B, and lower face view for debitage products. It is normally not drawn for unretouched products, but the object is always oriented according to the debitage axis.

- View E: view from the distal or apical extremity, known as end view. This view is useful for representing distal truncations, endscraper fronts, percussion or pressure platforms, etc.

- View F: view from the proximal or basal extremity, also known as end view. This view is useful for representing butts, striking platform preparations, and, for instance, in drawing Levallois cores.

Owing to the orthogonal relationship between views:

- the lengths of views A, B, C and D are identical;
- the outlines of views A and D are identical;
- the outlines of views B and C are identical;
- the outlines of views E and F are identical.

For the finished pencil drawing, the outline of certain views can therefore be traced and carried over.

The layout of views described above is known as the “French system” (fig. 43: 1) in contrast with the “American system” (fig. 43: 2). The latter is also based on orthogonal views, but the left profile is rendered on the left and the right profile on the right. We use the French system, but both systems may be encountered in published material.

It is important to associate the various views of an artefact with link lines for greater cohesion and readability. This is done with a short, wide horizontal dash (-) placed between two views towards the mid section. This symbol avoids confusion when several similar artefacts are presented in a single illustration. A dot is sometimes used in place of this symbol.

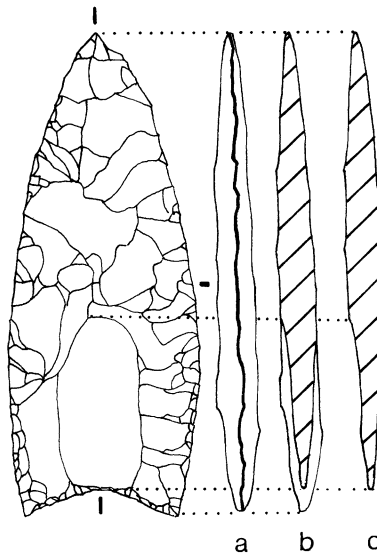

Fig. 44 — Different ways of describing the volume of an object. a : profile view. b : section view. c : section (longitudinal).

3.2. Sections and section views

The system of views outlined above allows the description of any object. However, descriptive views do not provide adequate precision in rendering complex morphologies or fine detail of treatment. Carefully chosen sections and section views can provide the necessary additional information¹¹⁰.

A section is the representation of the surface created by a plane sectioning an object (fig. 44c). The exact location of the section on the artefact is shown by two long broad dashes. The section is moved sideways and rendered on the right, although it is sometimes placed above or below the sectioned descriptive view for convenience of publication. Sections are hatched with parallel lines at 45° or 60° from the horizontal.

A section view represent the parts of the object situated both at and behind the sectioning plane (fig. 44b). Section views are more problematic to draw than sections and are less used. They are very useful for showing the morphology of the volume and the position of different parts of the object in relation to its axis.

Sections and section views can be drawn in any plane provided they are explicitly located. In general they are drawn vertically or horizontally in relation to the axes of the artefact. Oblique sections are harder to interpret, the eye being used to vertical and horizontal planes of reference (vertical axis of the human body, horizontal axis of the horizon).

Drawing sections and section views

For large and robust objects it is possible to use calipers - the outline is built by combining the two half-outlines derived from each surface. For smaller or more delicate objects, sections and section views can be constructed from other views already drawn and from measurements taken directly from the object.

¹¹⁰ Laurent, 1970.

4. Graphic design and technique

Three inseparable and necessary stages are involved in any drawing process :

- drafting;
- pencil drawing;
- pen and ink drawing.

4.1. Drafting

A draft is primarily a method of observation, which enables the illustrator to assess the number of views required for describing the object (fig. 45 : 1). It is a free hand drawing where proportions should be respected as much as possible. The directions of removals (negatives and positives) visible on the surface of the object are indicated by arrows. When the bulbs and negative bulbs are present, a dot is added to the arrow.

4.2. Pencil drawing

This involves three stages (fig. 45 : 2).

- drawing the outlines;
- drawing the arrises;
- shading.

Drawing the outlines (fig. 46 : 1 and 2)

The final result is highly dependant upon the care and accuracy with which the outlines are drawn.

The technique used to construct the outlines applies to all views, front, profile or end view. The object is positioned horizontally on the sheet of drawing paper, the face to be drawn towards the viewer. The orthogonal projection of the outline of the object on paper is achieved with the help of a dihedron (a folded index card) applied along the outer borders of the artefact. When the dihedron comes across an arris, this is indicated by a short dash. The number of projected points must be sufficient for the outline to be accurately recorded, only then does one link the dots up. It is thereby possible to obtain an accurate delineation, which will be perfected by the addition of millimetric micro-details pertaining to the delineation of the artefact.

Tracing the outline with a single bold sweep of the pencil applied along the edges of the object is strongly advised against. The delineation will be both deformed and enlarged owing to the thickness of the pencil, resulting in smoothed out angles and shallow concavities. Moreover, the projection can never be orthogonal, thus jeopardizing the subsequent steps.

Drawing the arrises (fig. 46 : 3 and 4)

They are drawn according to their orthogonal projection, *i.e.* in conformity with a perfectly vertical observation of the view to be drawn. Proceeding from the more simple to the more complex makes for a more accurate drawing.

The main arrises, which outline the negatives of the larger removals, should be drawn first, while the arrises associated with retouch should come last, ending with the smallest.

Transfer errors cannot be avoided, but if the progression is gradual, at least errors do not pile up.

The representation of the arrises is carried out visually and based on the drawing of the outline. For large artefacts, greater accuracy may be achieved by transferring a few conspicuous points (the intersection of two arrises, the boundaries of the cortical surface, etc.) with the help of a compass and two dihedrons.

Shading

Only shade and not projected shadow should be figured, *i.e.* shade on the artefact itself.

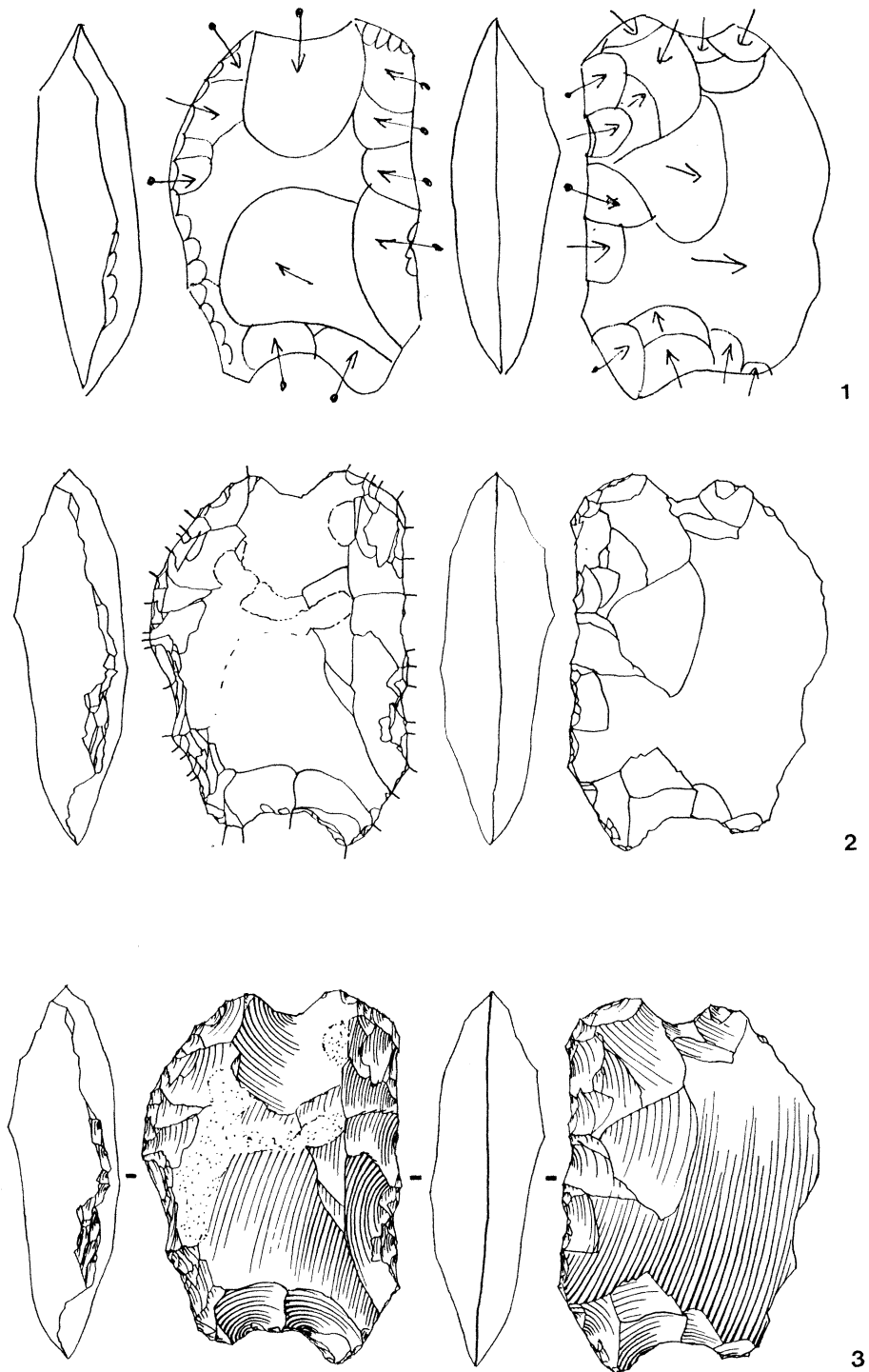

Fig. 45 — The stages involved in the drawing process. 1 : drafting, choice of views, directions of removals. 2 : pencil drawing, tracing the outlines and arrises. 3 : pen and ink drawing with direction lines.

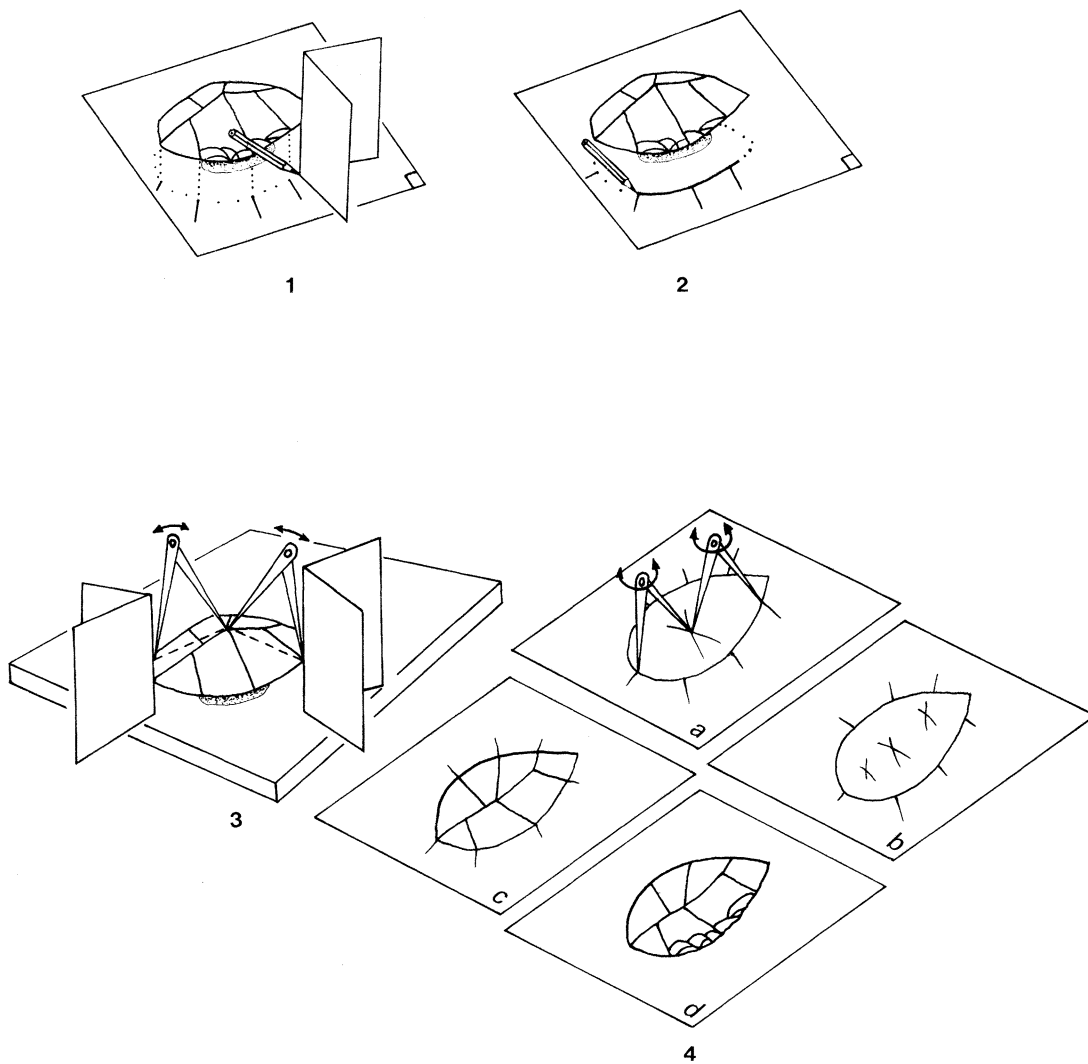

Fig. 46 — Tracing the outline and the arrises. 1 : orthogonal projection of points along the outline of the artefact. 2 : drawing the outline. 3 : drawing the arrises. Taking measurements of the artefact. 4 : transferring measurements of the arrises on paper. a : using a compass to transfer a point, b : transfer of conspicuous points, c : drawing the main arrises, d : drawing the retouches.

Shading is a means of expressing volume and is done with a pencil, in light hatching or grey flat tint.

The convention is that of a north-west light source, *i.e.* parallel rays at a 45° angle directed across the artefact from top left-hand to bottom right-hand. This can be obtained by adequately positioning a high intensity adjustable lamp over the face of the object to be drawn.

To shade an object it is necessary to find the separative line between light and shade. To do so, you should look at the object with one eye half open and the other completely closed. You will no longer be able to distinguish details and will only perceive solid masses. Where is the lightest patch, where is the darkest? What is the gradation of intermediate tone values between light and dark?

The tone values of chiaroscuro include four categories :

- values of light, or parts directly hit by light. If the surface is smooth, the light will be reflected and will radiate. The zones of shade always slightly spread over the adjacent zones of light. In order to obtain the desired relief it is therefore best to increase the size of the zones of light, so that they are rendered larger than they actually appear.

- values of half-light, or parts still directly lit, but with less intensity;
- values of shade, or parts that light does not touch directly;
- values of reflection, or parts left in shadow but nevertheless indirectly brushed by a small amount of light.

Pen and ink drawing should respect these values.

4.3. Pen and ink drawing

This is the final stage in the illustration of an artefact (fig. 45 : 3). Downstrokes of consistent thickness are used for the outlines and arrises. Some illustrators use a varying thickness of line for the arrises (broader in zones of shade) to create an impression of relief. However, this technique is advised against because the broadened line tends to be less precise and the general outlines will lack accuracy.

Borrowing from engraving techniques, the first lithic illustrators devised a graphical method that was adapted to prehistoric industries and rendered the three-dimensional aspect of the object, the nature of the material and the sequence of knapping events. Engravers use hatching to express volume; their parallel lines are rectilinear and of consistent thickness. The tone values of grey are rendered by more or less complex cross-hatching forming a lattice pattern. Where lithic technology is concerned, hatching fulfills a double purpose. The lines, similar to hachures, are used as a means of expressing relief and of showing in a highly stylized way how the object was made. For this reason they are known as *direction lines*. Imitating ripples, the direction lines represent the shock wave in the stone, which caused the removal of the flake. They originate at the impact point, from which they spread out concentrically. Fully rounded when they are close to the impact point, the direction lines straighten out as the distance from the impact point increases, without ever becoming rectilinear. This process highlights the negative bulbs and shows on a single drawing the entire chronological sequence of flake removals.

The direction lines are drawn using downstrokes and upstrokes. The line tapers to a point: the head of the line is thickish while the tail is very fine. This can only be achieved with a split-nib pen. The pressure of the hand bears on the nib, widening or narrowing the split to adjust the thickness of the line. The direction lines should all be parallel.

Based on the relief rendered on the finished pencil drawing, the values of shade and light are expressed by varying several parameters (fig. 47), the length of the direction lines, their thickness and their frequency:

- in zones of light the lines are few in number, fine and short; they cover about a third of the surface of each removal negative;
- in zones of half-light the lines are fairly numerous, thick and of middling length; they cover about half the surface of each removal negative;
- in zones of shade the lines are very numerous, very thick and long; they cover about two-thirds of the surface of each removal negative;
- in zones of reflection the lines are abruptly interrupted to express a zone of light within a zone of shade.

5. Materials and surfaces

5.1. Raw materials

The fundamentals of lithic illustration were established on the basis of flint artefacts.

The conventional method of representing flint in a stylized way uses downstroke and upstroke direction lines. What about other flaked stones, which do not have the same texture as flint? They should be differentiated (fig. 48). However “while it is highly advisable to portray the grain of the stone, this should never be done at the expense of an accurate technological representation”¹¹¹. The same principle of direction lines is followed, but the character of the lines and the background of the drawing are made to vary according to the textures of the different materials. Several different treatments are proposed hereafter.

¹¹¹ “... il est bien entendu que, s’il est hautement souhaitable que le grain de la roche soit exprimé avec soin, jamais la réalité technologique ne doit en souffrir”. Dauvois, 1976 : 52.

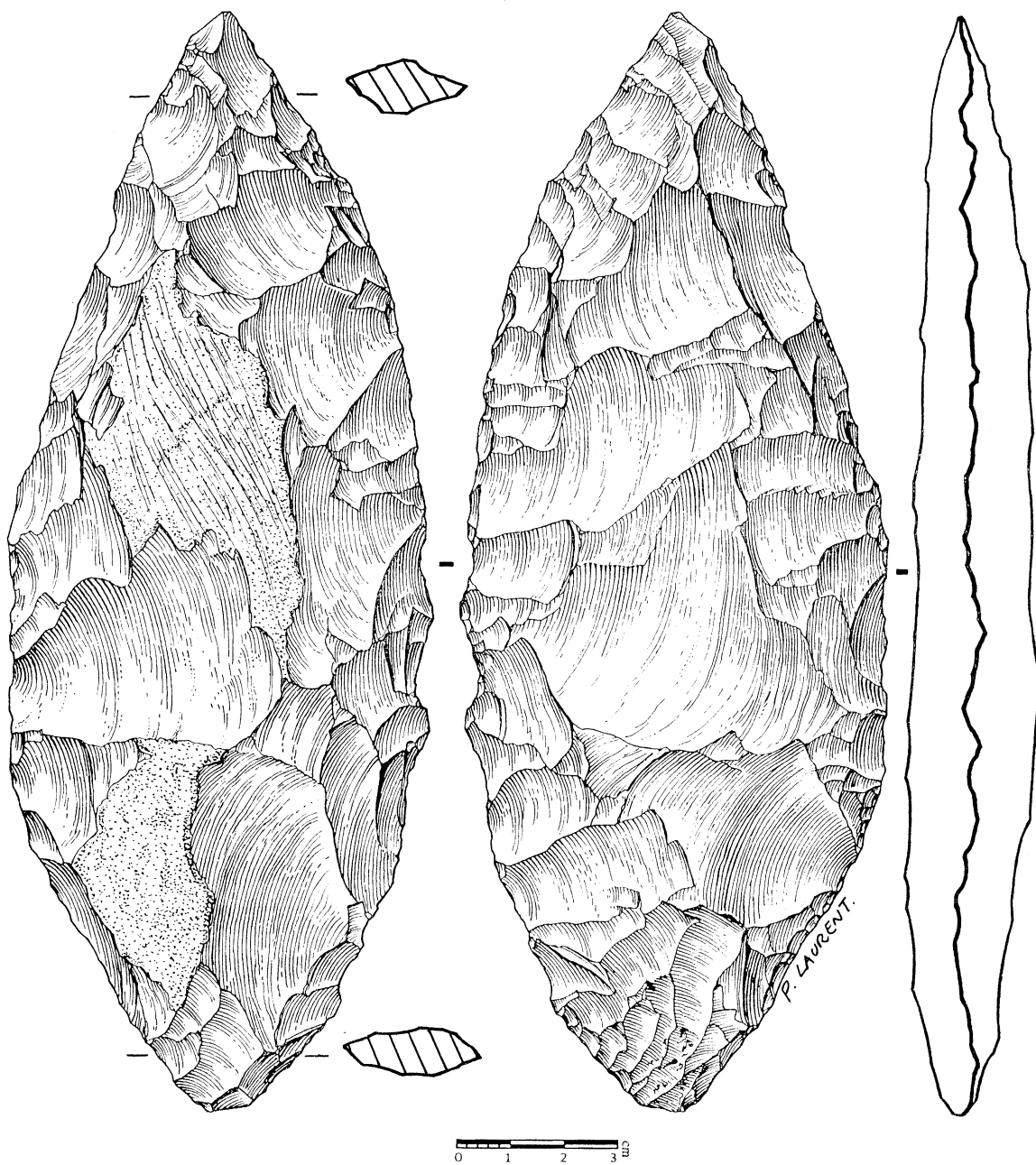

Fig. 47 — Uncompleted laurel leaf. Solutrean, flint, Pech de la Boissière, Dordogne (Smith 1966b : fig. 39).

Self-adhesive shading films are used for the background; they may be combined to form more complex patterns. These screens are then scraped and roughened with a razor blade or a scalpel.

Sedimentary rocks

- flint : downstroke and upstroke direction lines (fig. 48 : 1);
- jasper : downstroke and upstroke direction lines, the length of which should vary but little within each removal negative, in order to portray the great regularity of the material (fig. 48 : 2);
- limestone : successive parallel series of regular downstroke and upstroke direction lines (fig. 48 : 10);
- sandstone : stippled direction lines on a shading film (fig. 48 : 4).

Igneous rocks

- rhyolites, phonolites : upstroke discontinuous direction lines on a stippled or dashed shading film according to the grain of the stone (fig. 48 : 5);
- basalt : upstroke and downstroke direction lines on a stippled shading film (fig. 48 : 6);
- obsidian : white upstroke and downstroke direction lines made with a razor blade on a blacked-in background (fig. 48 : 7). Obsidian can also be portrayed in the same way as flint, with a black dot positioned beside the drawing to specify the raw material (fig. 7 : 3 and 5).

Metamorphic rocks

- quartzites : according to the grain, progressively fading stippled direction lines or downstroke and upstroke discontinuous direction lines, with or without shading film (fig. 48 : 3 and 8).

Mineral varieties

- quartz : successive parallel series of jagged downstroke and upstroke direction lines (fig. 48 : 9).

5.2. Natural surfaces

Cortex

According to their texture, cortical surfaces are shown by stippling or small vermiculation. Shading off is obtained by adjusting the density of stippling or vermiculation to the varying values of light and shade. The boundaries of cortical areas are indicated by a solid line. Sub-cortical areas are shown by the same method as cortical areas, but without indication of their boundaries (figs. 40 and 47).

Natural surfaces

Flat natural surfaces are represented by series of short rectilinear discontinuous downstrokes forming more or less closely set parallel lines.

Encrustings

Their representation should be figurative, although slightly simplified.

Fossils, geodes, cracks

All such elements are an intrinsic part of the material and should be portrayed in a figurative way, without any unnecessary details. They indicate the nature or the origin of the illustrated rock.

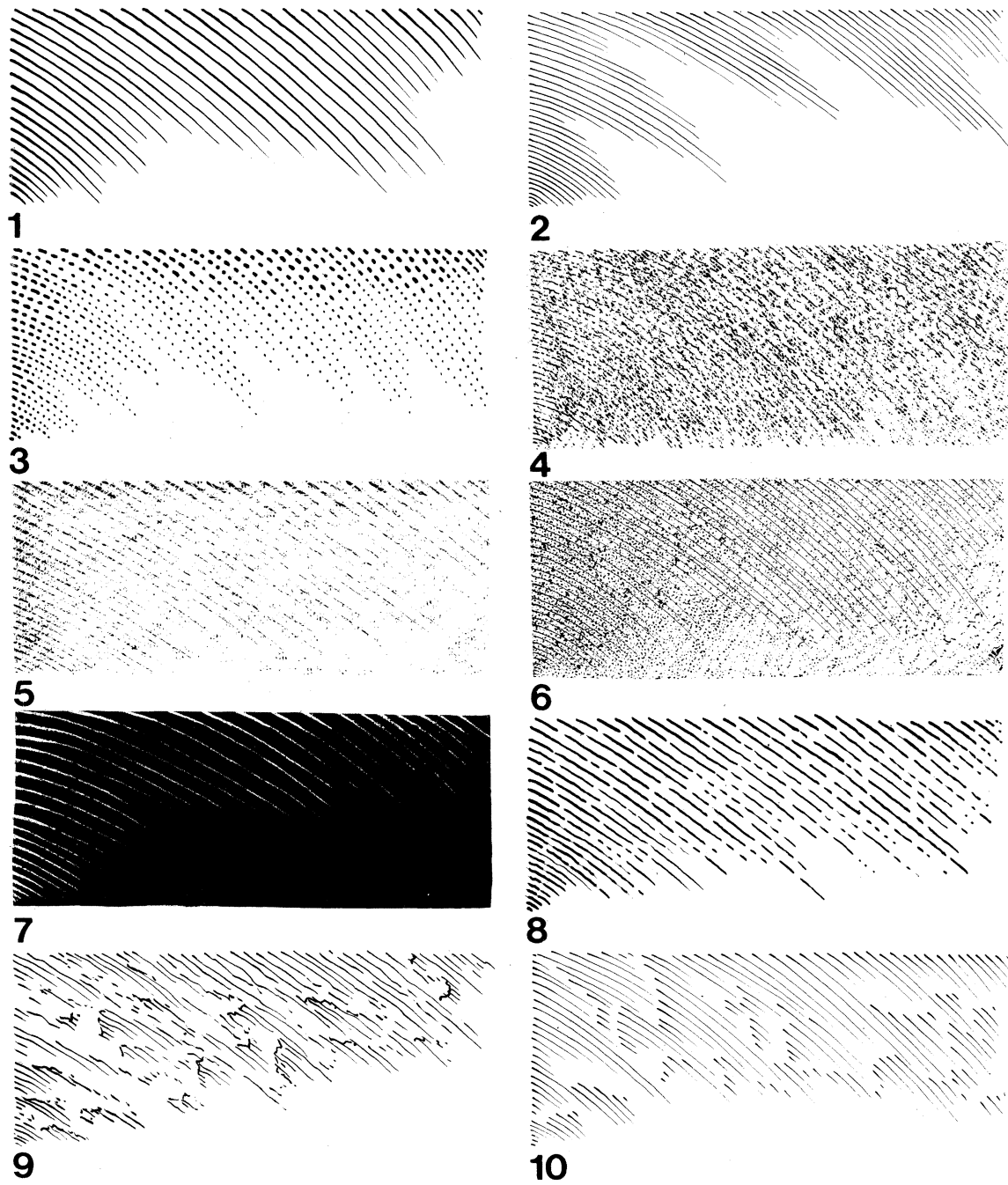

Fig. 48 — Graphical treatment of various raw materials. 1 : flint. 2 : jasper. 3 : fine-grained quartzite. 4 : sandstone. 5 : rhyolite. 6 : basalt. 7 : obsidian. 8 : coarse-grained quartzite. 9 : quartz. 10 : limestone.

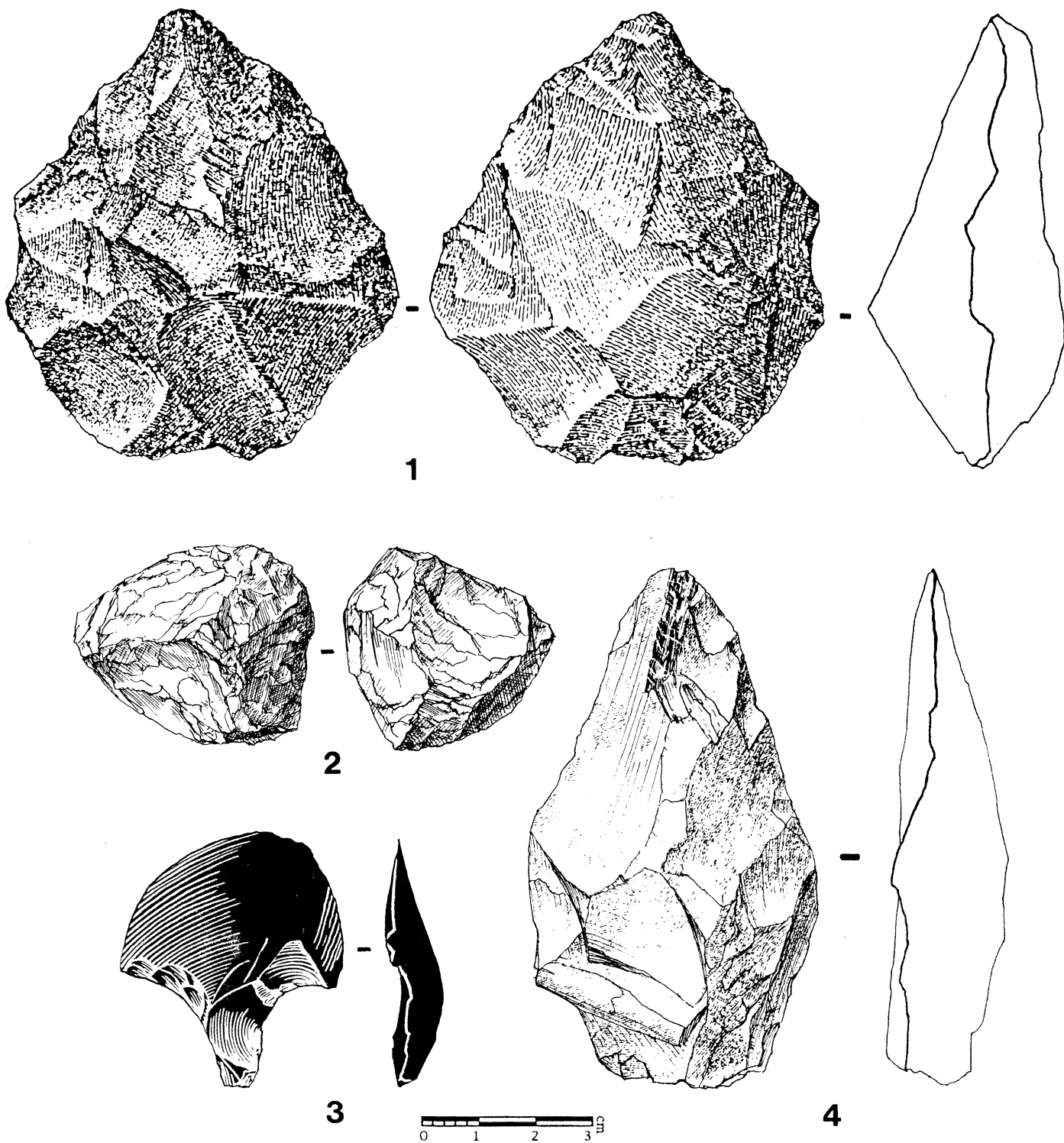

Fig. 49 — Graphical rendering of the texture of various materials. 1 : quartzite, shading film and split-nib pen strokes, handaxe, Yemen. 2 : quartz, split-nib pen strokes, core, Isenya, Kenya. 3 : obsidian, razor blade strokes and ink flat tint, tanged flake, *mata'a*, Easter Island. 4 : phonolite, shading film and split-nib pen strokes, handaxe, Isenya, Kenya.

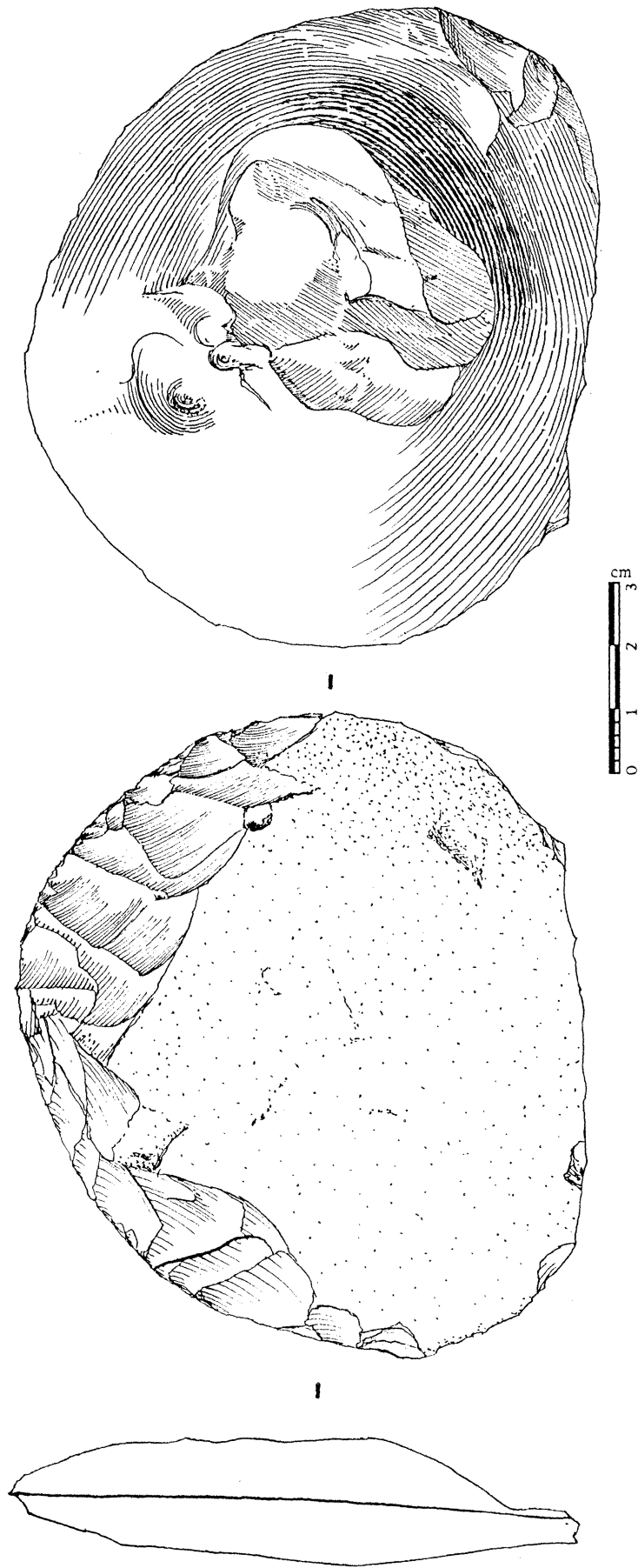

Fig. 50 — Large convex Mousterian sidescraper on a frost-fractured flake, flint, La Combette, Vaucluse (Brugal *et al.*, 1994).

5.3. Alterations

Frost pits, "pot lid" fractures and their complements

Whatever its origin, thermal damage is shown by concentric direction lines (fig. 50).

Crazing

Frost damage or heat-altering (intentional or unintentional) causes crazing to develop on the surface of the object; the network of fine cracks is depicted by a lattice of short broken lines.

Patina and heat treatment

Changes in the texture, colour or sheen of some patinated or heat-treated artefacts may occur (fig. 1 : 7). This difference between original and altered state is figured by drawing two illustrations of the same view. The first drawing shows the original aspect of the artefact, the second portrays only the altered zones. On each of the two drawings the zones that are not emphasized are finely hatched.

When artefacts bear multiple patinas, the same view is repeatedly drawn to show each of the successive patinas.

5.4. Additions

As studies on additions (ochre, bitumen, etc.) are relatively recent, no conventional method of portrayal has yet been devised. They are drawn in a figurative way or indicated by fine grade shading film (fig. 51). Ochre-bearing artefacts are best rendered by the use of colour.

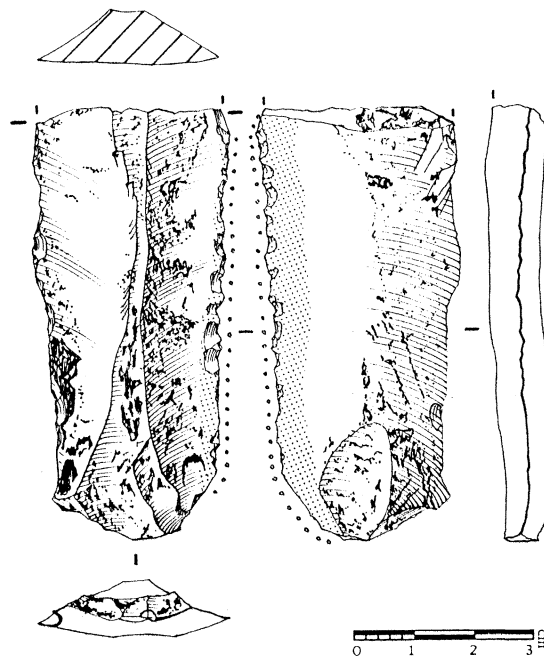

Fig. 51 — Proximal fragment of a Canaanean blade bearing traces of gloss (stippled shading film and dotted line) and bitumen (small areas of black flat tint), flint, Kutun, Iraq (Anderson, Inizan, 1994 : fig. 3).

6. Symbols

Although multiple views allow the comprehensive representation of a three-dimensional object, symbolic conventions are added to the figurative drawing in order to help the reading along. These symbols highlight the technological information indispensable to the comprehension of the way the artefact was manufactured and used. In some cases, one of the descriptive views can be skipped if symbols are used. For instance, the lower unretouched face of an endscraper need not be drawn provided the direction of the debitage axis - when it differs from the morphological axis - is indicated by a symbol.

Some symbols have become established by usage and those most currently used are listed below. While the symbols pertaining to knapping are accepted, there are no specific conventions for symbolizing traces of use. Microwear studies have only recently developed, and this may explain the lack of homogeneity in the conventions devised to symbolize function. Illustrators, microwear analysts and photographers also should co-operate to establish consistent rules, for this is a means of communication essential to microwear studies.

- Debitage products





Debitage is symbolized by a crossed arrow with or without a dot (fig. 53).

The arrow indicates the orientation of debitage. It corresponds with the debitage axis. The crossed arrow symbolizes the orientation and the direction of debitage. The dot indicates the presence of a butt.

When objects are oriented according to their morphological axis, this symbol allows the representation of the butt-and-bulb part and of the debitage axis. It is positioned outside the drawing of the upper or lower face view. When it accompanies the upper face view, this symbol substitutes for the drawing of the lower face view when the latter face is unretouched (fig. 58 : 9). When the artefact displays a double bulb, the symbol is a double crossed arrow. The double dot indicates the presence of a butt.

While the dot denotes the presence of a butt, the symbol does not exempt the illustrator from drawing the end view, which shows the exact morphology of the butt. The symbol is indeed but a token of presence, it is necessary but not always sufficient.

The following symbols are *strongly advised against* in association with debitage :

	Presence of a butt. It can be mistaken for the link between two views or for the mention "obsidian". It is indicative neither of the orientation nor of the direction of debitage.
	Orientation and direction of debitage, and presence of a butt. When the butt is lacking the symbol is irrelevant.
	Orientation and direction of debitage. There is nothing to indicate whether the butt is present or not. The head of the arrow alone without the shaft does not accurately show direction.
	Orientation and direction of debitage, and presence of a butt. These two symbols are already used for burin blows.

We advocate the symbols shown in figure 52.

- Breaks (figs. 51 and 53)

The term is used indiscriminately for both intentional and accidental ruptures.







	<p>Orientation and direction of debitage 1 : without a butt 2 : with a butt</p>
	<p>Orientation and direction of debitage and presence of a double bulb 1 : without a butt 2 : with a butt</p>
	<p>Break</p>
	<p>1 : modern retouch (or break) 2 : archaeological retouch</p>
	<p>"Siret" accident 1 : without a butt 2 : with a butt</p>
	<p>Burin blow 1 : without a negative bulb 2 : with a negative bulb</p>
	<p>Previous burin blow 1 : without a negative bulb 2 : with a negative bulb</p>
	<p>Wear traces (blunting, abrasion)</p>
	<p>Gloss</p>
	<p>Obsidian artefact</p>

Fig. 52 — Symbolic conventions in figurative drawings.

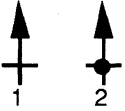
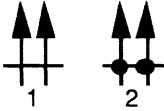
Clean breaks are indicated by two short parallel dashes on either side of the broken zone. Barring exceptions, breaks do not require being represented on any particular view. However, when the break can be observed on the upper or lower face view it is shaded and hatched with direction lines like the rest of the drawing.

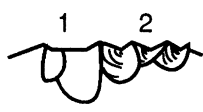
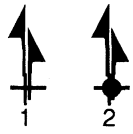
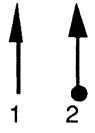
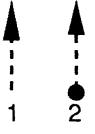
Some objects display modern breaks or retouches, which should be left blank. Any blank area is considered to be of modern origin; it is therefore very important that the entire surface of the drawing should be inked (using dots, dashes, direction lines).

- Knapping accidents

Flakes that display a “Siret” accidental break are oriented like any other flake, with a symbol accompanying the proximal part: a double crossed arrow pulled out of line. A dot denotes the presence of a half-butt (fig. 34 : 7).

Languette breaks are indicated by two short, wide dashes on either side of the fracture, and by the side view of its missing complement.

The same conventions apply to *nacelle* breaks (figs. 7 : 3, 4, 5).

- Special techniques

Microburin blow technique (fig. 33)

The “*piquant-trièdre*” is shown on the upper face view and is supplemented by the outline drawing of the missing part, *i.e.* the microburin. This device allows an unambiguous rendering of the technique itself, which is otherwise difficult to portray.

Burin blow technique (figs. 57, 58, 59, 79)

The removal negatives associated with this technique are emphasized by arrows. These are oriented and directed according to the burin blow negatives they indicate. Numbers specify the order of removal, when the latter can be determined.

The last burin blow is symbolized by a solid arrow. When the negative bulb is present a dot is added to the arrow.

The negatives of previous burin blows are symbolized by broken arrows (short dashes).

- Macroscopic wear traces (figs. 51 and 53)

Blunting is the outcome of any action that has altered a cutting edge by making it less sharp. Abrasion refers to the wear of an edge through friction.

These two types of wear are symbolized by a dotted line outside the drawing. The length and position of the dotted line indicates the altered zones. The intensity of wear is empirically shown by varying the size of the dots.

- Gloss (fig. 51)

This refers to the shiny aspect of a surface brought about by friction. Gloss is symbolized by applying a fine grade stippled shading film to all the surfaces where it can be observed, both on the upper and lower faces. Sometimes, a line of small regular circles or dots accompanies the shading film symbol. It is positioned outside the drawing, along the gloss-bearing zone on the upper or lower face.

Assessing

The quality of a published illustration should be assessed to ensure that it can be correctly interpreted. Indeed, an aesthetically pleasing drawing is not necessarily an informative one. There are six indispensable criteria to be considered for the adequate assessment of a graphical representation.

1. Scale

Illustrations must always include a bar scale specifying the standard of measurement. For the sake of consistency and legibility, all the drawings for one article should have the same scale. If drawings displayed on the same plate do not have the same reduction factor because of layout constraints, a bar scale must be related to each of them.

Bar scales are often substituted for by verbal scales (*e.g.* FS for Full Scale) or by representative fractions in the caption. This is strongly advised against because the true proportions will not be retained when the drawing is reduced. Some illustrations have been

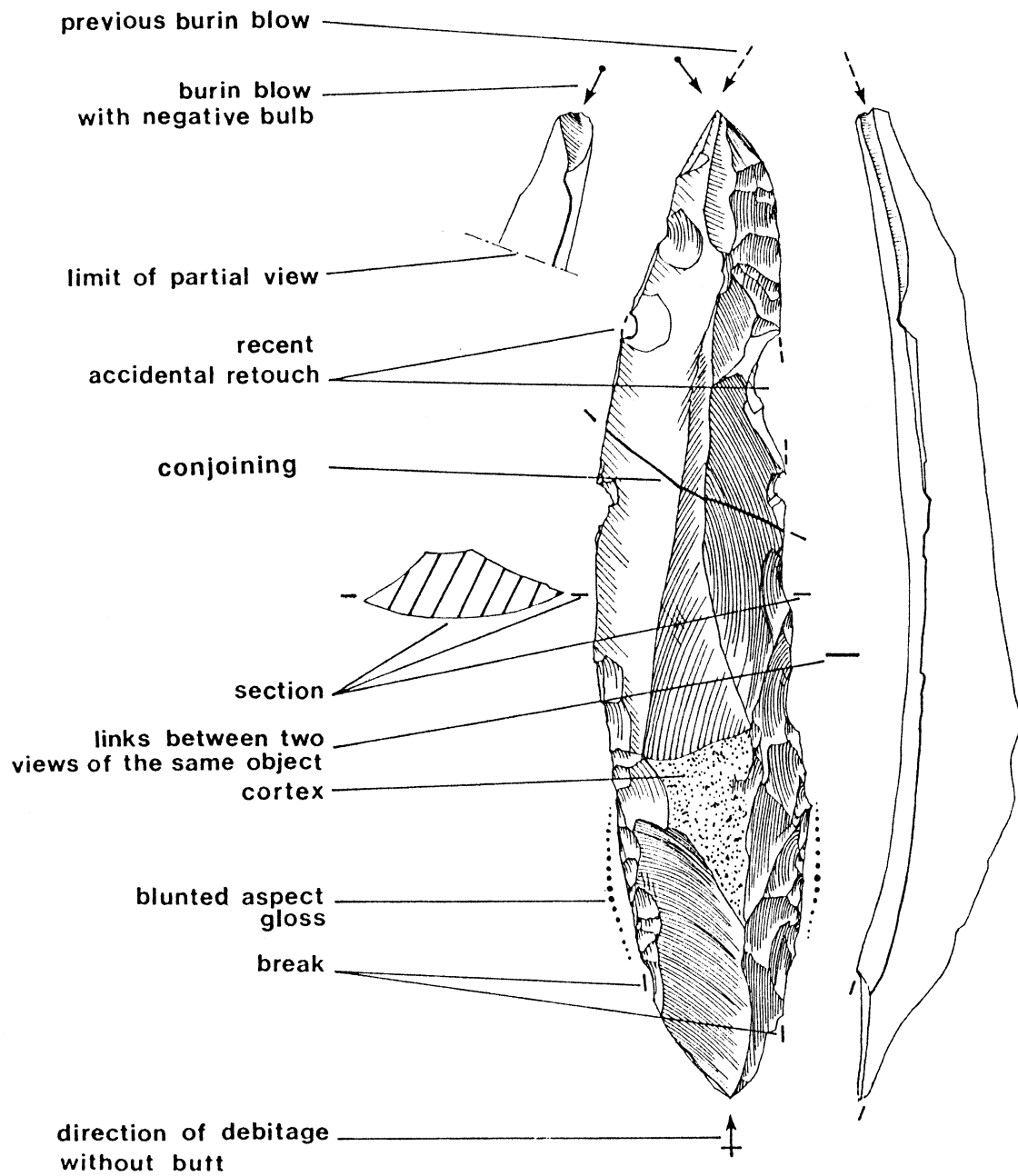

Fig. 53 — Illustration of the main symbols used.

enlarged or reduced a number of times according to the successive publications they appear in, so that the scale indication has become quite meaningless.

2. Orientation

Have the layout conventions been respected?

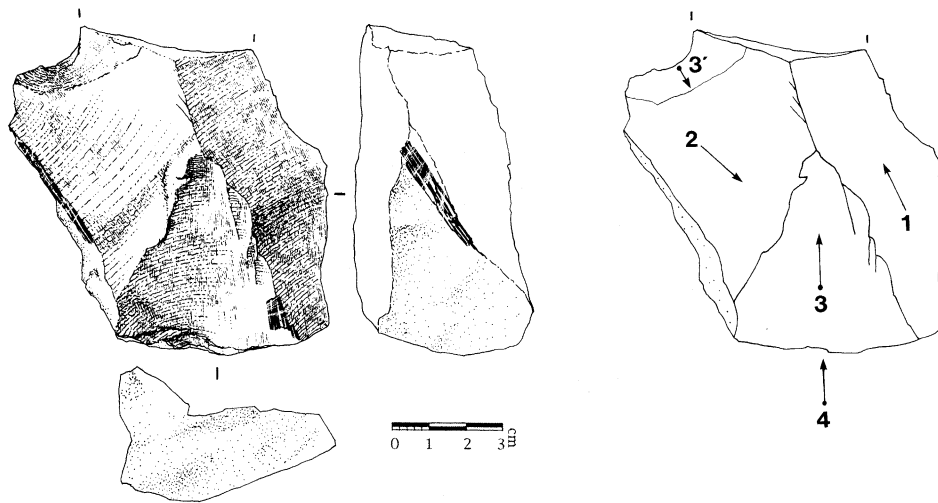

Fig. 54 — Schematic representation of an object : descriptive drawing of a flake and diacritic diagram of the same flake, Acheulean, phonolite, Isenya (Kenya).

3. Descriptive views

Does the layout of views correspond to the “French system” or to the “American system”? In either case, are the views consistent with the system used? When only one view is represented, it is often view A (the principal view).

When more than one view is represented, are the lengths of views A (front view), D (back view), B and C (right and left views) identical? If they are dissimilar, it is to be suspected that orthogonal projection was not used and that the drawings therefore lack accuracy.

4. Removals

Is the order of flake removal perfectly clear? One should examine the direction lines. Do they highlight the negative bulbs? If they do not, is this technologically possible? If they do, are the negative bulbs consistent with the other removals?

One should also examine the removals. Are the hackles portrayed? Can one understand how the removals relate to one another on the different faces of the artefact? Is it possible to produce a diacritic diagram from the drawings?

5. Symbols

Are they explicit? Is their choice judicious?

6. Style of drawing

What do the outlines look like? Are they slacker drawn? Do they show a few angles or none at all? Is the delineation accurate (small convexities and concavities) or approximative? In the latter case, the outlines have probably been drawn with a single circular sweep of the pencil. The initial lack of accuracy makes for a faulty final drawing.

Is the relief adequately rendered? The thickness of the objects is gauged from the side views or the sections, and then compared with the relief of the principal view. Do the drawings lack relief? Has relief been over-emphasized? It is possible by such means to assess the degree of care and realism with which the morphology of the objects has been portrayed.

Schematizing

1. Schematic representation of an object

The diacritic diagram, devised by M. Dauvois (1976), is a schematic drawing of the object. Its purpose is to show with economy of graphical means the final sequence of actions in the manufacture of the artefact (fig. 54).

It consists in a full scale outline drawing, which leaves out both direction lines and relief, and involves only one view, generally view A or view D. The usual techniques of orthogonal projection are applied. The direction, the orientation and the chronology of removals are

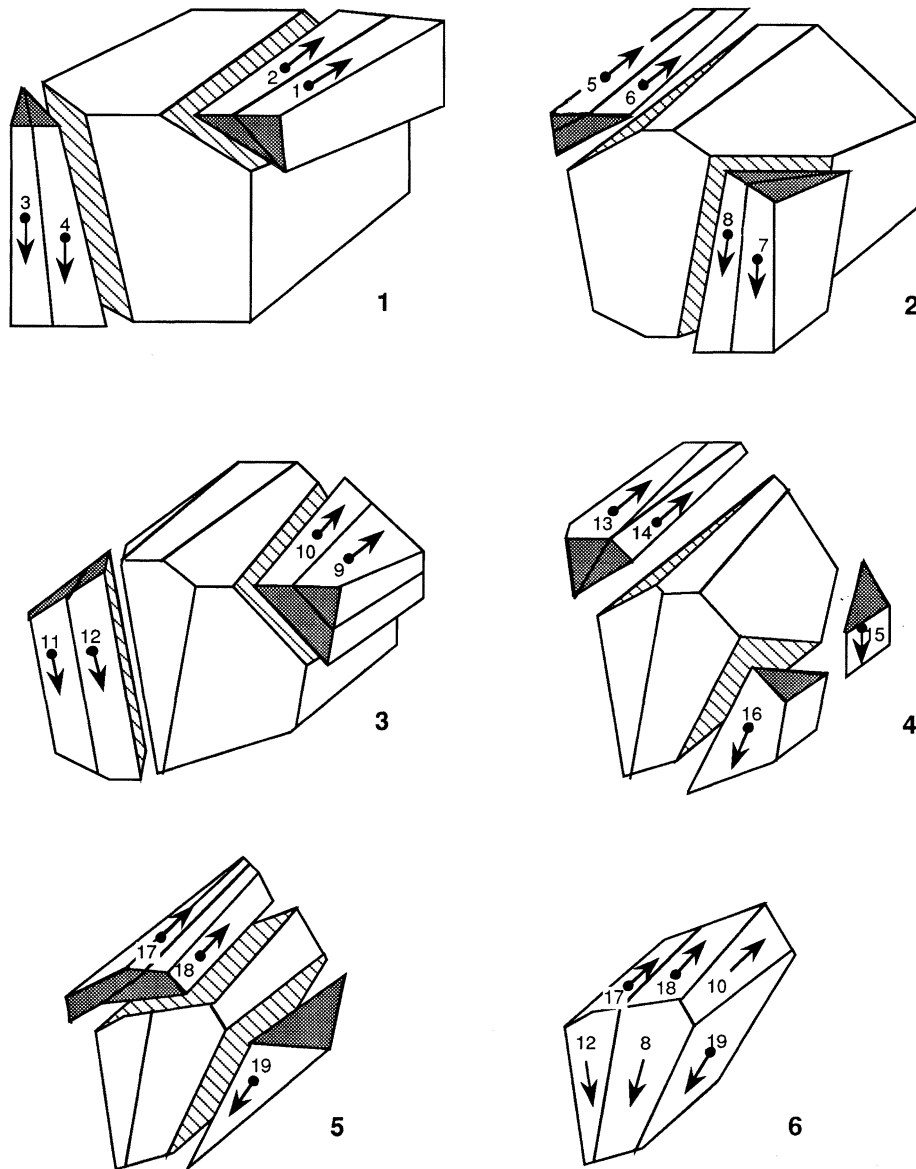

Fig. 55 — Schematic representation of a *chaîne opératoire*. 1 to 5 : detachment of wide thick flakes by means of the exploitation of a block of raw material according to alternatively secant and subparallel debitage planes. 6 : spent core.

indicated by numbered arrows. The presence of bulbs or negative bulbs is denoted by a dot on the end of the arrows.

2. Schematic representation of a *chaîne opératoire*

The diacritic diagram portrays only one stage of the *chaîne opératoire*, whereas the schematic representation of a *chaîne opératoire* aims at restoring the entire sequence of technical actions on a single illustration. It is concerned with the object as project, whereas the diacritic diagram is concerned with the object as result.

One should always begin with a scale-free view in perspective of the object and trace back the previous phases to the initial virtual blank. The choice of the view depends on the amount of information it will yield, most often the front view in perspective is selected. Planar sections and section views give the exact volume of the object. Computer-aided design is perfect for this type of diagram, which can be conducted in two different ways.

- Figurative diagram (fig. 22)

Perspectives are treated as they would in an ordinary drawing, including direction lines, relief, symbols, etc. Shading screens are used to emphasize the most informative planes.

- Abstract diagram (fig. 55)

Perspectives are treated in outline drawing, as in a diacritic diagram, figuring only outlines, arrises and numbered arrows. The removals are treated as planes, portraying neither concavities nor convexities. A hatched pattern is used for the removal negatives of each phase, a stippled pattern highlights the striking platforms.

Chapter 8

Terminological lexicon

A

ABRASION. A general term, which describes the action of wearing away by friction; it is used here when this action is carried out to remove **overhangs**¹¹² from cores (to facilitate blade removal, in particular). Such abrasion can mainly be seen and felt on the *angle de chasse* of debitage products¹¹³, and is also sometimes perceptible on cores. It should not be confused with an intentional **polish**, or with **blunting** caused by use; it is a technical **preparation**, which therefore does not affect the lower face.

ABRUPT. A term referring to the **angle of retouch** or removal (fig. 56 : 1).

ADDITION. By addition we understand any kind of detectable matter that has been subjoined to a tool, whether intentionally or not. Additions are excellent indicators of hafting. They can be of mineral (bitumen (fig. 51), ochre, etc.) or vegetal origin (wood, gum, etc.).

ALTERNATE. An adjective of **position** (fig. 75 : 3). Retouch removals are referred to as alternate when they are removed from a

face along one edge, and subsequently from the opposite face along the other¹¹⁴.

ALTERNATING. An adjective of **position** (fig. 75 : 4). It describes removals alternately stemming first from one face and then the other, on the same edge of a tool¹¹⁵.

ANGLE DE CHASSE. An expression conventionally referring to the angle between a **butt** and an upper **face** (fig. 5), and also to its measurement. The sharpness of this angle, and above all the morphology and state of the surface of this part of the flake (prepared, unprepared, blunted, cortical, etc.) will provide information about the techniques and methods of debitage.

ANGLE OF RETOUCH. The angle formed by removals relative to the face from which they stem. These can be (fig. 56) :

- **abrupt** : approximately 90°;
- **semi-abrupt** : approximately 45°;
- **low** : very acute, roughly 10°.

These three terms are widely used, but since angles can be accurately measured all sorts of classification systems are possible.

112 Words in bold type refer to other terms in the lexicon.

113 Tixier, 1972.

114 Bordes, 1961 : 29.

115 The terms “alternating” and “alternate” have become established by usage, but it must be admitted that they can be mistaken one for the other.

ANVIL. A block of relatively hard stone placed on the ground or steadied by other means¹¹⁶, and used as a solid base for :

- striking a core in order to flake it, striking a chunk of raw material in order to shape it, applying a burin blow to a burin, etc. ;
- retouching a flake (a blade, a bladelet) with a hand-held hammer.

Anvil retouch : see **crossed**.

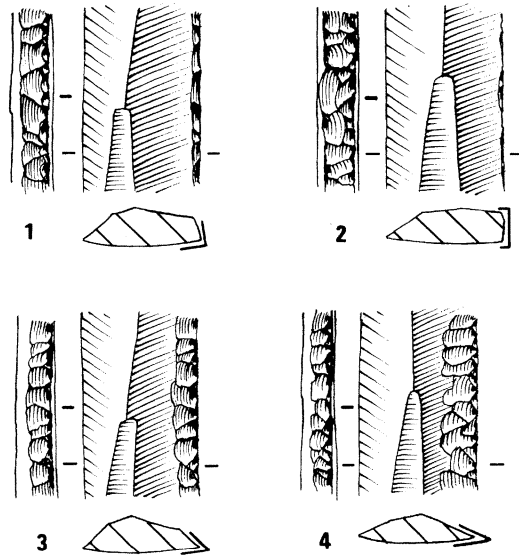

Fig. 56 — Angle of removals. 1 : abrupt. 2 : crossed abrupt. 3 : semi-abrupt. 4 : low.

APEX (of a pyramidal core). The pointed end of a fluted pyramidal core (fig. 74 : 2), referring therefore only to cores flaked by pressure. It is sometimes removed to avoid plunging, thus becoming a characteristic waste product.

ARRIS. A term used in the context of technological morphology : refers to the line formed by the meeting of two removal negatives, or of one negative with the cortex (fig. 6, 9). Avoid the confusion with **ridge**.

¹¹⁶ An anvil can be held in the hand. We owe the expression “passive hammerstone” (*percuteur dormant*) to F. Bordes (1961 : 13).

ATYPICAL. This very controversial term often conceals an inability to recognize an object. How can a burin be atypical? It either is, or is not, a burin. “Atypical” categories could be invented for each type of object, but a complete description would be far preferable, or the use of appropriate adjectives : ill-made, irregular, unfinished, etc.

B

BACK. A general morphological term describing a surface that extends along the length of a blank, and is more or less perpendicular to the two faces. This surface can be : **cortical**, **unretouched**, **prepared**, or formed by **abrupt retouches**. We restrict the use of this word to this sole meaning.

BACKED. An edge is said to be backed when the continuous regular retouch applied to it is abrupt enough not to create a new cutting edge. An edge can therefore be backed by **abrupt** (fig. 56 : 1) or **semi-abrupt retouch** (fig. 56 : 3), modifying an **unretouched** edge, a **cortical** edge, etc.

BASE. The base is the extremity opposed to the presumed active part of a tool. The word “base” or “basal” should never be substituted for the expression “proximal extremity”, when it refers to a debitage product. A base can be non-proximal : in the case of sharp, backed bladelets, the tip is often part of the bulbar area. The base is therefore distal (fig. 69 : 5). This term (and not the word “butt”), should also be used for bifacial pieces, irrespective of their original blank.

BIFACIAL. An adjective of **position**. By definition, bifacial removals concern the two faces of an object. Both series of removals must, in all cases, be located on the same part of an object, and stem from the same edge (fig. 75 : 5).

BLADE, BLADELET. It has long been agreed that if “the length of a flake is at least equal to twice its width, it is therefore a blade. [...] English-speaking authors, among others, make a distinction between true blades and blade-like flakes, a true blade showing traces of previous parallel

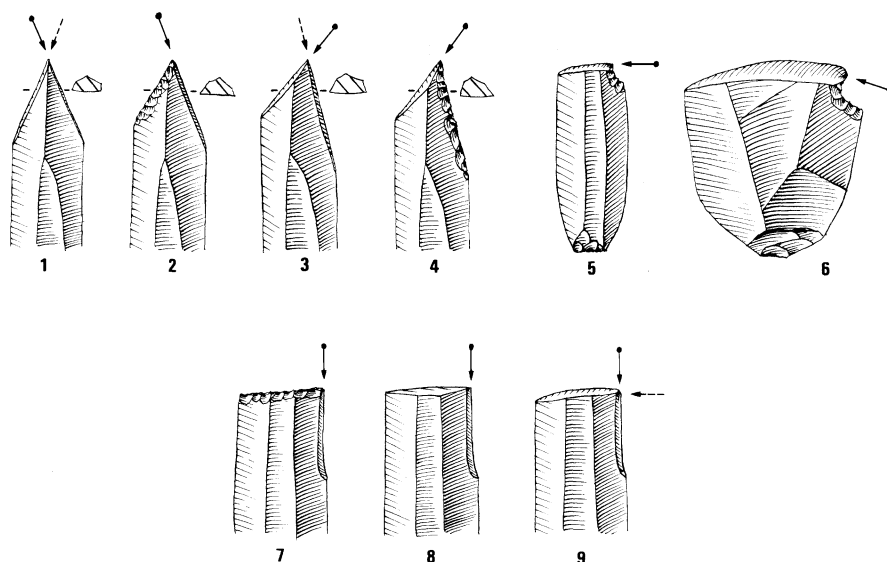

Fig. 57 — Various examples of simple burins. *Axis burins*. 1 : dihedral. 2 : on truncation. “*Déjetés*” *burins*. 3 : dihedral. 4 : on lateral retouch. *Transverse burins on notch*. 5 : on a blade. 6 : on a flake. *Angle burins*. 7 : on truncation. 8 : on transversal break. 9 : on transversal burin facet.

removals on its upper face, and also having more or less parallel edges. Although the distinction is perfectly valid in theory, it is often difficult to make in practice, and will therefore be disregarded¹¹⁷. It is only used when classifying broken pieces.

A bladelet is a small blade. Within each industrial complex, a blade/bladelet limit can be established and quantified. This has been attempted by one of the contributors, but only for the Epipalaeolithic of the Maghreb¹¹⁸.

BLANK. Any element from which an object is knapped, shaped, flaked or retouched. It can be a nodule, a slab, a cobble, a debitage product, etc.

BLUNTING. The alteration of an edge, rendering it less sharp. “The adjective blunt is vague, and does not provide any informa-

tion about the causes that produced this surface condition. This general term applies when no particular detail can be detected by superficial observation on the new surface”¹¹⁹.

BREAK. A general term, which makes no assumptions as to the causes of breakage, whether intentional or not (see **fracture**).

BULB. A more or less pronounced conchoidal relief, which develops on the lower face of a **flake**, radiating from the point where percussion or pressure is applied. It can be preceded by a cone, but only in the case of Hertzian fractures. The bulb results from the propagation of the **fracture front**, when the flake is detached. It can be double or even triple, and can show **bulb scars** (fig. 5).

BULB SCARS. This kind of mark can be observed on a bulb or on a negative bulb. It corresponds to the formation of a secondary¹²⁰ or parasitical flake, which is

117 Bordes, 1961 : 6. “...[si un] éclat est allongé, de telle manière que sa longueur soit deux fois, ou plus, supérieure à sa largeur, on a affaire à une lame. [...] Certains auteurs, principalement de langue anglaise, distinguent entre lames vraies et éclats laminaires. La lame vraie porterait sur sa face supérieure la trace d’enlèvements antérieurs parallèles et aurait également des bords plus ou moins parallèles. Cette distinction, en théorie parfaitement valable, est souvent difficile à faire dans la pratique et nous ne la retiendrons pas”.

118 Tixier, 1963 : 36-39, and see p. 71.

119 Dauvois, 1976 : 211. “Le qualificatif émoussé est vague et ne renseignera guère sur les causes qui ont produit cet état de surface. On peut utiliser ce terme quand un examen superficiel ne décèle pas de détail particulier de la nouvelle surface”.

120 Dauvois, 1976 : 181.

produced at the very moment the flake breaks off (fig. 6).

BURIN BLOW TECHNIQUE. This is a particular retouch technique (p. 84). The term “burin blow” was probably coined by H. Breuil¹²¹, and was defined by M. Bourlon¹²² as that which “describes the action of making burin facets”. A **facet** (fig. 60) is obtained through the removal, by pressure or percussion, of a **burin spall** (fig. 61) from a flake, blade, or bladelet, which may or not have been previously prepared to this end. The **tip** of a burin is therefore formed by the meeting of at least one burin facet with any surface liable to be used as a striking (or pressure) platform for the burin blow (fig. 58), such as :

- flat surfaces or unretouched edges (dihedral burins) : cortex, unretouched surfaces, breaks...
- surfaces obtained by retouching : truncation, retouched edge, back, notch...
- surfaces obtained by special techniques : intentional fracture, Clactonian notch, *piquant-trièdre*, other burin facets, in which latter case the first of the two facets (at least) of these (dihedral) burins can be made by starting either from an unretouched edge or from a truncation; the second burin blow removes the truncation and yields a prepared spall (a more reliable method, perhaps). A burin on a retouched edge may therefore represent but an early stage in the manufacturing process, before further modifications. Any classification is possible, depending on the criteria given precedence to : the combinations of surfaces, the positions relative to the morphological axis of the blank, to its debitage axis, etc. (fig. 59).

BURIN FACET. This refers to the negative surface created by the removal of a burin spall. A single facet can result from several previous spalls, a single burin blow can remove several spalls and form one or more facets.

The angle of a facet can vary in relation to the faces of the blank. Rarely situated on the upper face, it can be perpendicular to the lower face (fig. 60 : 1), lightly angled

(fig. 60 : 2) or sharply angled, almost parallel to the lower face (fig. 60 : 3); the burin is then said to be *plan*.

BURIN SPALL. Part of a blank that has been detached by the **burin blow technique**. Unretouched, it presents all the characteristics of a flake, in the broader sense of the term (fig. 61). Conventionally, these objects have long been called “burin blow bladelets”. However, in 1954, E.-G. Gobert¹²³ rightly pointed out that they are not always bladelets. “They do not possess the two cutting edges of bladelets”. When referring to the fragments struck off from burins during their manufacture or sharpening, the expression “burin spall”, or simply “spall”, is therefore more appropriate.

The term sharpening spall (see below) is restricted to the spalls created by the sharpening process; that is, to those fragments struck off from the same edge, after the first burin spall.

- **Primary spalls** : the spall produced by the first burin blow usually has a triangular cross-section if it removes an unmodified portion of the edge.

When the edge of the blank has undergone preparation, the cross-section is trapezoidal. By regularizing the edge, this method allows the removal to split off more smoothly. In this case, the removals associated with the preparation can obviously never concern the lower face of the spall, which is then referred to as being “prepared”. Special attention should be paid to these objects, as they can be mistaken for backed bladelets through failing to check that the lower face is absolutely unretouched (fig. 61 : 8, 9).

- **Sharpening spalls** : a sharpening spall can be identified by the presence of at least one earlier burin facet on its upper face. If the order of burin blows can be determined from the spalls (which is not always the case), then the second spall is the first sharpening spall, the third spall is the second sharpening spall, and so on (fig. 61 : 2, 3).

- **Plunging spalls** : the plunging of spalls is a frequent accident. It occurs when the

¹²¹ Breuil, 1909.

¹²² Bourlon, 1911. “*désigne l'action de fabriquer les pans d'un burin*”.

¹²³ Gobert, 1954 : 447, note 2 and fig. 2. “*Elles n'ont pas les deux tranchants des lamelles*”.

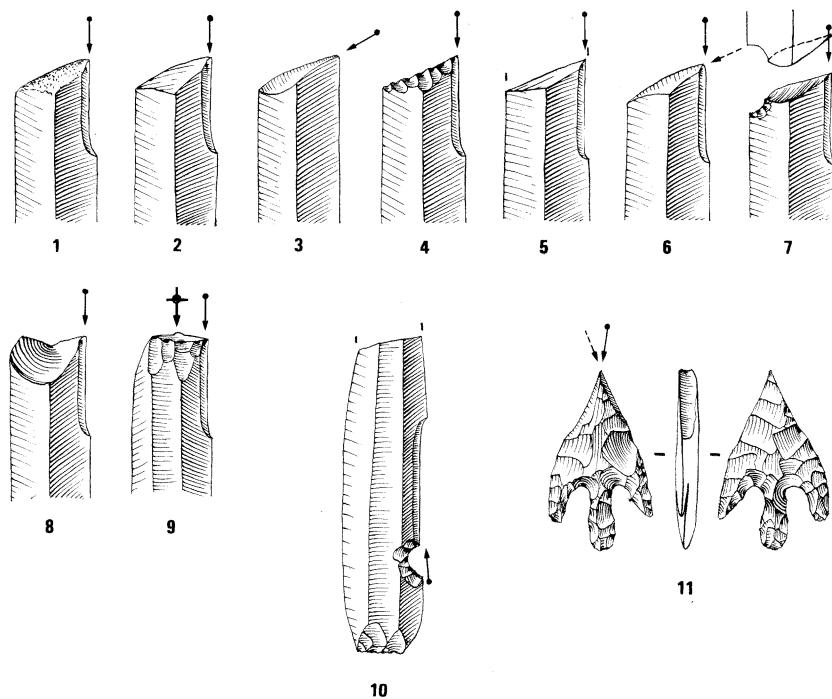

Fig. 58 — Surfaces liable to be used as striking or pressure platforms for burin blows : a cortical surface (1), an unretouched debitage surface (2), an unretouched cutting edge (3), a retouched surface (4), a transversal break (5), a burin facet (6), a “*piquant-trièdre*” (7), a Clactonian notch (8), a butt (9), a notch (10), the tip of a bifacial arrowhead (11), etc.

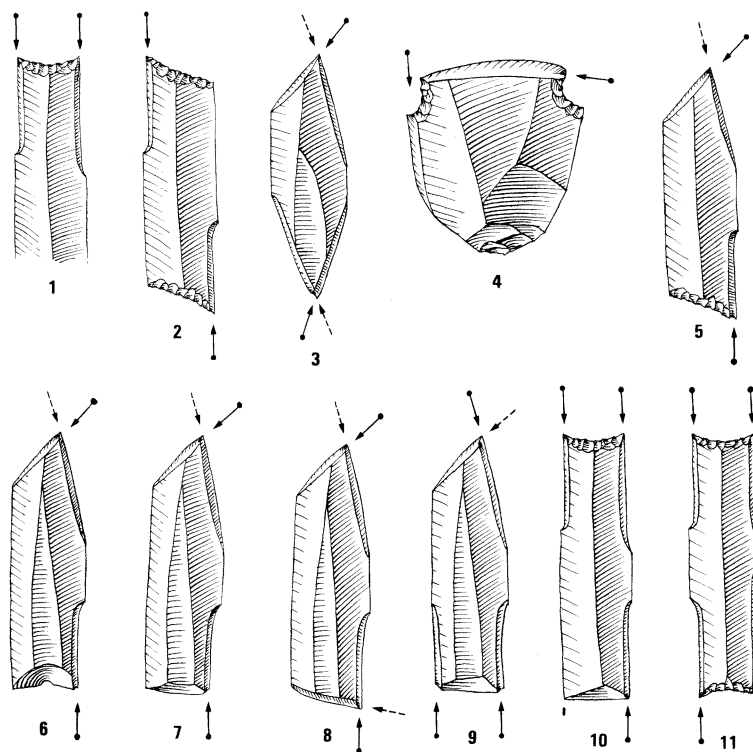

Fig. 59 — Various examples of multiple burins. *Double burins*. 1 : on truncation. 2 : alternate on truncations. 3 : axis dihedral. 4 : on notches. 5 : dihedral *déjeté* and on truncation. 6 : dihedral *déjeté* and on Clactonian notch. 7 : dihedral *déjeté* and angle dihedral. 8 : dihedral *déjeté* and on transversal burin facet. *Triple burins*. 9 : dihedral *déjeté* and double on break. 10 : double on truncation and simple on break. *Quadruple burins*. 11 : on truncations. Burins 5, 6 and 10 belong to the *multiple mixed* type.

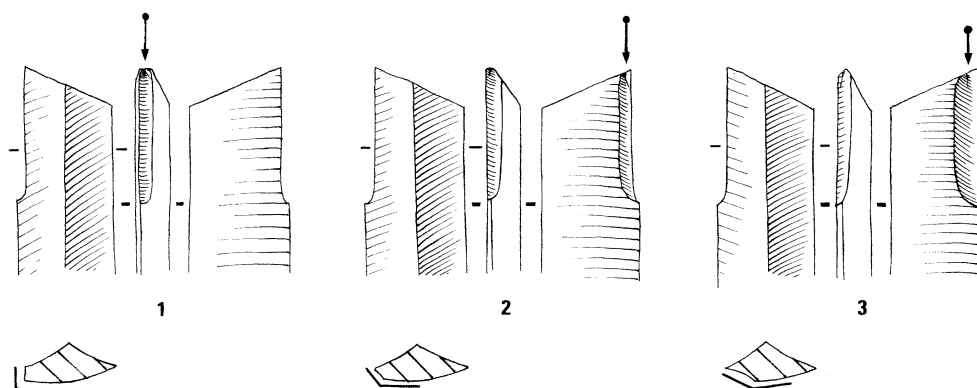

Fig. 60 — Inclination of a burin facet to the lower face of a blade. 1 : perpendicular. 2 : slightly angled. 3 : sharply angled.

spall, instead of ending along the edge to which the burin blow has been applied, arches in the opposite direction and removes the entire end section of the tool (fig. 61 : 4, 5). See **plunging**.

- **Hinged spalls** : the opposite accidental effect occurs when the spall is shortened by an outward arching of the fracture plane, which leaves a characteristic hook on the burin (fig. 61 : 6). See **hinged**.

- **Twisted spalls** : these are caused by helicoidal fractures, which may accidentally occur when the burin blow is applied (fig. 61 : 7).

Careful scrutiny of the spalls provides valuable information on the production, sharpening and transformation methods and techniques of burins brought into play in the various lithic assemblages.

BURIN TIP. That part of the burin from which the removal(s) made by the burin blow(s) stem. It consists of at least three surfaces (fig. 57).

BUTT. The butt of a **flake** (in the broader sense) is the part of a striking or pressure platform detached during removal. The nature and morphology of a butt therefore depends on that of the striking or pressure platform (whether prepared or not), and on the technical procedures applied (fig. 62).

1) If the butt bears no traces of preparation, it is natural, cortical, and of varied morphology.

2) When it bears traces of preparation, the butt can be indicative of knapping techniques and methods. In this event, butts can be :

- **flat**, showing a single knapped surface ;
- **dihedral**, showing the negatives of two previous removals, separated by an arris ;
- **faceted**, showing several preparation negatives (facets), and therefore of varied morphology (rectilinear, convex, concave, etc.).

A butt can consist of a tiny surface. In this case, the terms **linear** or **punctiform** are applied.

In addition to these general terms by which butts are defined, there are conventional expressions that apply to special types of butt, and correspond to technical procedures. For instance :

- the "**chapeau de gendarme**"¹²⁴ : the profile of this very distinctive butt should be looked at face-on ; while this type of butt is common in Levallois debitage (for a good, preferential impact point), it occurs during every period, irrespective of the methods applied ;

- the **winged** butt, which should be looked at end-on ; this type of butt, which results from the removal of two exactly superposed flakes, occurs throughout prehistory, but this method of debitage is only systematic in specific regions and periods (Egyptian Neolithic, Near Eastern Early Bronze Age) ;

- the **spur** butt, which should be looked at from underneath ; this morphology is characteristic of Upper Palaeolithic blade debitage (particularly Magdalenian).

Also indicative of techniques and methods, the angles between the butt and the upper

¹²⁴ Bordes, 1947.

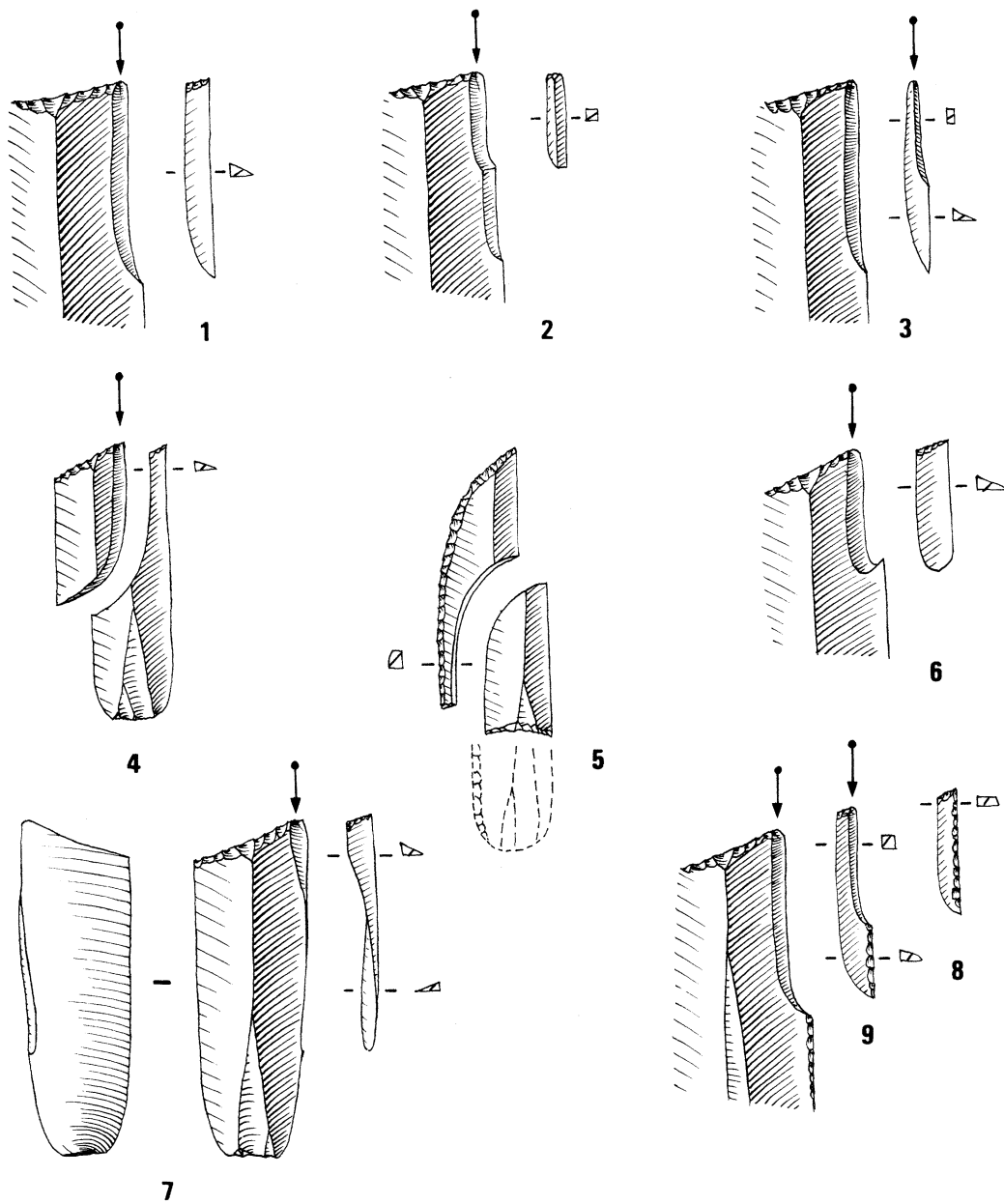

Fig. 61 — Schematic illustration of the main types of burin spalls. 1 : first spall. 2, 3 : sharpening spalls (second spalls). 4 : plunging spall (angle burin on distal truncation). 5 : plunging spall (angle burin on a proximally truncated arched backed blade). 6 : hinged spall. 7 : twisted spall. 8, 9 : first spall and sharpening spall removing part of the edge prepared before the burin blow.

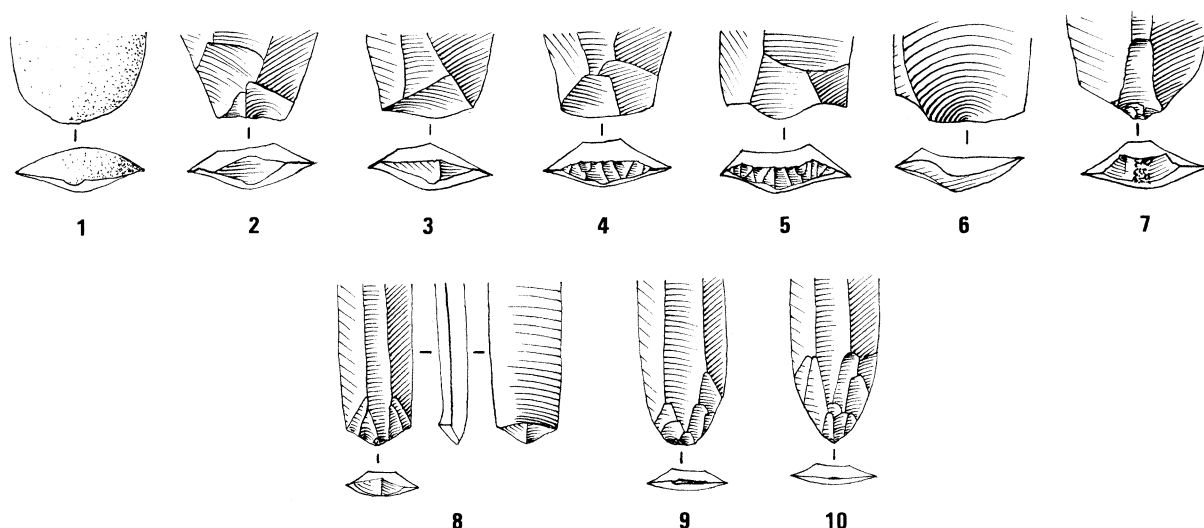

Fig. 62 — Various types of butts. 1 : cortical. 2 : plain. 3 : dihedral. 4 : faceted. 5 : “*en chapeau de gendarme*”. 6 : winged. 7 : pecked. 8 : spur (“*en éperon*”). 9 : linear. 10 : punctiform.

and lower faces of the flake are defined by the *angle de chasse* and the **flaking angle**. When the latter is very obtuse, the butt is said to be **canted**.

C

CANTED. A descriptive term applied specifically to the **butt**, when it forms a distinctly obtuse angle with the lower face.

CARÈNE (CARÉNAGE). Litterally “hull” (“careenage”), from the vocabulary of naval architecture. The term refers to the longitudinal convexity of the debitage surfaces of a blade core, which is best represented on cores with a single striking platform (fig. 29 : 1 and fig. 64 : 5)¹²⁵.

CHANNEL-FLAKED. The expression describes a bifacial piece from which an elongated flake has been removed along the longitudinal axis, in order to thin one or both faces, without reaching the edges¹²⁶. Channel-flaking (or **fluting**) can be carried out by direct or indirect percussion (fig. 63), or by pressure-flaking. This method is not known in the Old World¹²⁷.

CHAPEAU DE GENDARME. An expression applied specifically to a form of faceted **butt** (fig. 62 : 5).

CINTRAGE. Litterally “centering” in architecture. The term refers to the transversal convexity of the debitage surfaces of a blade core (perpendicular to the ridges)¹²⁸.

CLACTONIAN. 1. Denotes a notch obtained by a single blow (fig. 34 : 4), irrespective of the blank, the culture, or the geographic location.

2. Also refers to a type of debitage¹²⁹.

CONCHOID. A rarely used synonym of **bulb**.

CONE. This denotes the morphology sometimes linking the **butt** to the **bulb**. The term is very appropriate in the case of an incipient cone¹³⁰, a fissure that develops in the form of a right-angled cone from the surface of a piece of raw material, when the percussion (with a hard or soft hammer) is not followed by a removal.

CONJOINING. Conjoining involves matching pieces or fragments after having

125 Term suggested by D. Cahen (1984).

126 Crabtree, 1966.

127 Smith, 1963.

128 Cahen, 1984.

129 Turq, 1988.

130 Breuil, 1932.

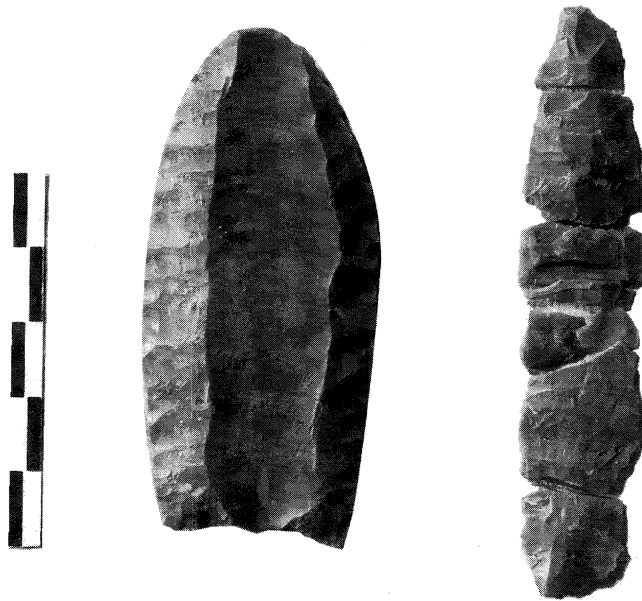

Fig. 63 — Fluting experiment. Bifacial projectile point roughed out by G. Titmus (percussion), preformed by D.E. Crabtree (pressure), fluted by J. Tixier (indirect percussive), and its characteristic channel-flake broken during removal, Texas flint, U.S.A. (Photo J. Tixier).

identified their positive and negative knapping surfaces (debitage, retouch), or their fracture surfaces, and then fitting them together and verifying that they are in fact complementary.

CONTINUOUS. Technologically speaking, the opposite of discontinuous¹³¹. When the latter term is not applied, the continuity of removals can be taken for granted, as the expression “continuous retouch” has been given a specific meaning relative to typology¹³².

CORE. A block of raw material from which flakes, blades, or bladelets have been struck, in order to produce blanks for tools.

CORE-LIKE. A term used to describe certain tools (especially scrapers or burins), which exhibit a core-like shape owing to multiple removals; no assumption is thereby implied concerning the nature of the artefact.

CORTEX. An alteration of the outer part of a block of raw material, termed “patina” in

geology. For prehistorians, **patina** has a different meaning, and so has the term “neocortex” (p. 91), which is not yet in general use.

CORTEX REMOVAL. Removing the cortex is not a goal in itself. It is part of the operation of **preliminary flaking** when the raw material is in its original unworked state.

CORTICAL. Denotes the presence of **cortex**. Depending on its extent and on its distribution, the associated terms are: cortical reserved zone, cortical zone, cortical base or cortical butt, entirely cortical face, etc.

COVERING. A term referring to the **extent** of removals (fig. 67 : 4).

CREST. A term associated with the **shaping out** of a core, in blade or bladelet debitage. This shaping out is achieved by (usually bifacial) removals, which create a **ridge** consisting of two series of negative bulbs (fig. 64 : 1). This ridge will guide the debitage of the first blade, the **crested blade**. This blade will necessarily have a triangular cross-section, the removed crest line making up the two sides of the blade’s upper face (fig. 64 : 2).

131 But the opposite of denticulated for Laplace (1964).

132 Sonneville-Bordes, Perrot, 1956 ; Tixier, 1963.

If the morphology of the raw material is such that no preparation is necessary, the term “natural crest” is used. The preparation of the crest may require removals from a single **versant** only of the planned crest if the shape of the raw material is appropriate, or if a negative blade removal is used as a striking platform for the preparation removals (fig. 64 : 5). This may occur when the core is shaped out again during debitage, and yields a crested blade with one flat versant (fig. 64 : 6a, 6b).

A crest can also be a simple by-product of the shaping out of a core, without being intended to guide a crested blade :

- this is the case for Levallois blade cores, or for “*livres de beurre*” cores from the Grand-Pressigny ;
- especially in Upper Palaeolithic industries, only one of the crests associated with the shaping out of a core may be intended to guide the first blade, while the opposite crest(s) are only there to balance the morphology of the core, to provide a firmer grip, or possibly to help immobilize the core.

CRESTED BLADE. See **crest**.

CROSSED. 1. The first meaning combines the notion of **position** (since removals stem from both faces, fig. 75 : 6) with the notion of **angle** (since the removals are more or less at right angles to each of the faces, fig. 56 : 2). One way of achieving this is by **anvil retouch**¹³³.

2. The word is used in a second sense to denote the orthogonal directions of blade or bladelet removals from cores with two, three, or four striking platforms (fig. 29 : 3).

CRUTCH. A knapping tool for the pressure-flaking of blades (fig. 73 : 1, 3). It can also be used for pressure-retouching¹³⁴. (fig. 30 : 2).

¹³³ Tixier, 1963.

¹³⁴ Crabtree, 1968.

D

DEBITAGE. A term conventionally used to denote the intentional knapping of blocks of raw material, in order to obtain products that will either be subsequently shaped or retouched, or directly used without further modification. Refers also to the tangible results (**debitage products**) of this action.

DEBITAGE AXIS. A straight line that embodies the direction in which the **fracture front** develops during the removal of a flake (fig. 41). It passes through the **impact point**, and divides the **bulb** into two equal parts¹³⁵.

DEBITAGE PRODUCTS. A term referring to all removals resulting from the knapping of a core, *i.e.* to all flakes in the broader sense of the term : those resulting from preparation, potential tool blanks, and all waste products. A product not modified by retouch is termed **unretouched**.

DEBRIS. No other term should be used to denote shapeless fragments whose mode of fracture cannot be identified, and which cannot be assigned to any category of objects¹³⁶.

DELINEATION. A term describing the outline of an edge created by a line of removals. This edge can be (fig. 65) :

- rectilinear (and not “straight”)
- concave
- convex
- regular
- irregular

In various combinations, these five general shapes can give rise to specific delineations, such as (fig. 65) :

notch
denticulated
shoulder, cran
nose
tongue
tang
long narrow tang
 etc.

DENTICULATED. An adjective of **delineation**, indicating a succession of irregular adjacent notches (fig. 65 : 5).

¹³⁵ Bordes, 1961 : 6 ; Dauvois, 1976 : 24.

¹³⁶ Bordes, 1947.

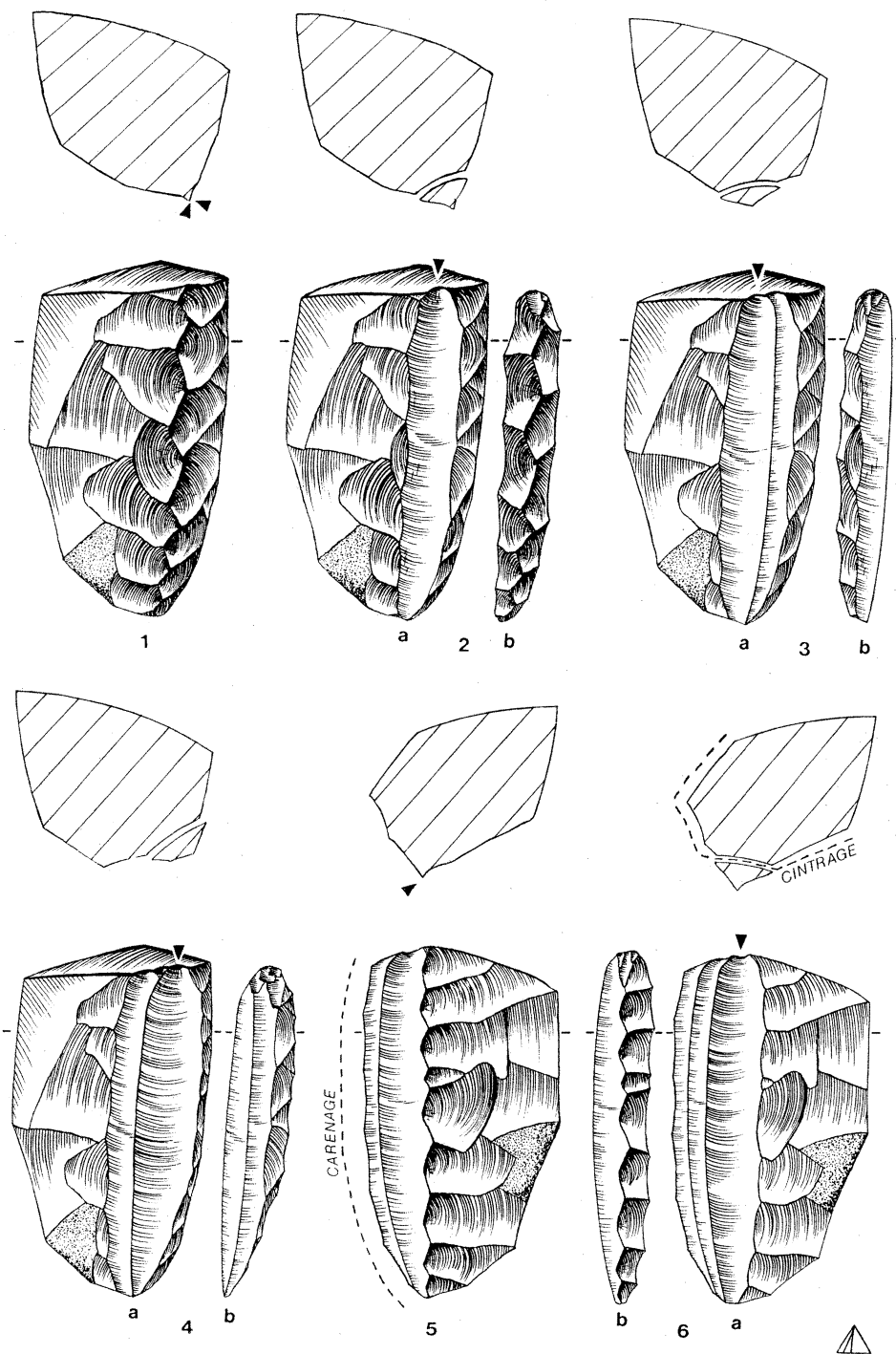

Fig. 64 — Schematic illustration of blade debitage on a crested core. 1 : core shaped out by means of a crest with two prepared versants. 2a : first removal. 2b : the corresponding crested blade. 3a, 4a : second and third removals. 3b, 4b : the corresponding blades showing part of the preparation of the crest. 5 : preparation of a crest with one prepared versant during debitage. 6a, 6b : removal and corresponding crested blade.

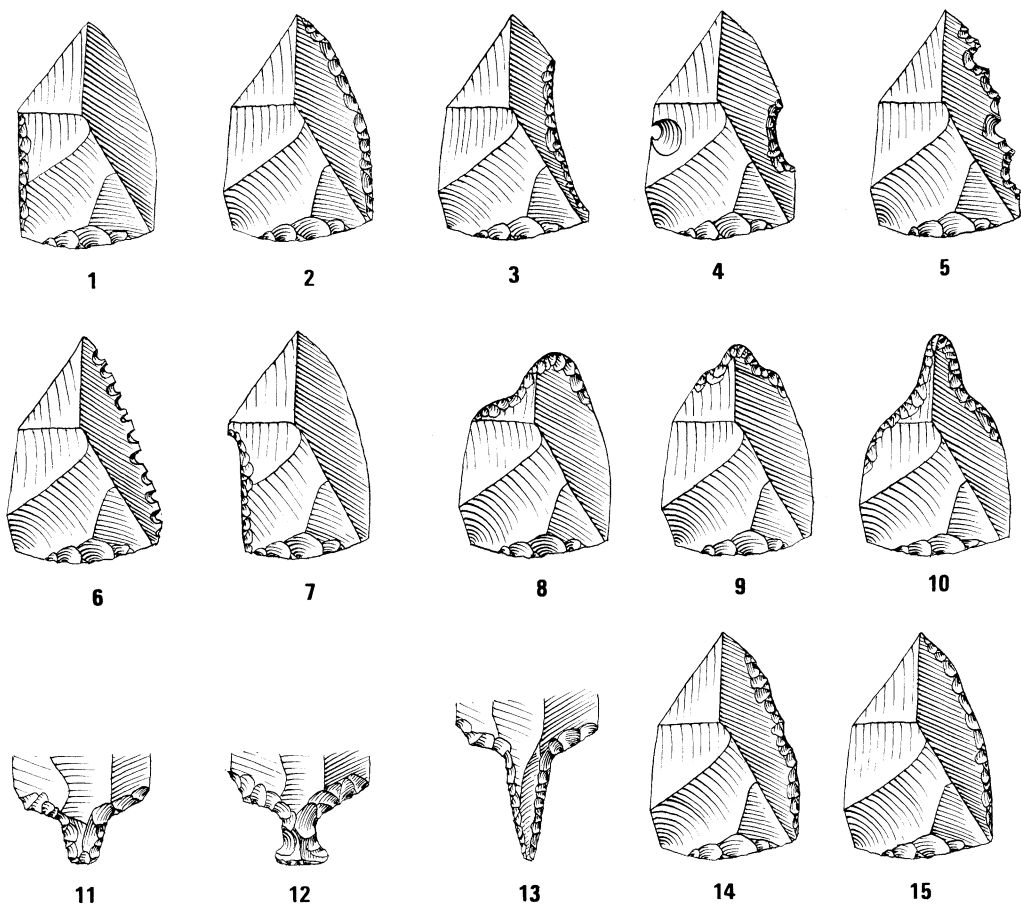

Fig. 65 — Delineation of the edge created by a series of removals. 1 : rectilinear. 2 : convex. 3 : concave. 4 : notched. 5 : denticulated. 6 : serrated. 7 : *cran*. 8 : shoulder. 9 : nose. 10 : tongue. 11, 12 : tang. 13 : long narrow tang. 14 : irregular. 15 : regular.

DIACRITIC DIAGRAM. A full scale outline drawing figuring outlines and arrises, but leaving out direction lines; it shows the boundaries, the debitage axes (often surmised), and the chronology of removals (fig. 54) (see p. 126).

DIHEDRAL. A general morphological term. See under **burin** and **butt** for the particular meaning taken on when applied to these words.

DIRECT. 1. An adjective of **position** applying to retouch removals originating from the lower face. It therefore only concerns **debitage products** (flakes, blades, bladelets) (fig. 75 : 1).

2. Direct percussion : see **percussion**.

DIRECTION LINE. Refers to a pen and ink drawing technique : each of the parallel downstroke and upstroke lines used for

expressing volume and rendering the directions of debitage and retouch.

DISCONTINUOUS. An adjective qualifying the **distribution** of removals along an edge (see **continuous**) (fig. 66 : 1).

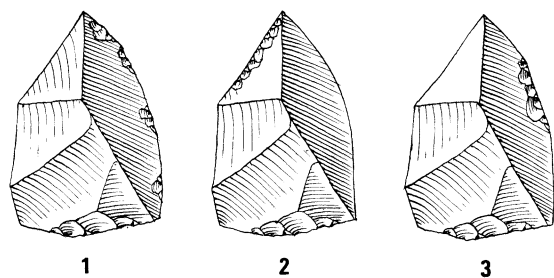

Fig. 66 — Distribution of removals along an edge. 1 : discontinuous. 2 : total on the distal edge. 3 : partial on the right edge.

DISTAL. An adjective of **localization** (fig. 69 : 1, 3) qualifying the end of the blank that is opposite to the **proximal** end. Applies only to debitage products (flake, blade, bladelet).

DISTRIBUTION. The term refers to the distribution of retouch removals along an edge (fig. 66). A series of removals is said to be **partial** when it does not occupy the entire length of an edge; the term "total" is thus self-defining. A series of removals is **discontinuous** if there are one or more interruptions along a single edge.

E

EDGE. The outline of an object. The word can be applied to retouched and unretouched debitage products (edges of blades, flakes, etc.), as well as to tools made from natural blanks. In the case of a debitage product (fig. 5), the edges do not include the butt, which is itself a surface and is therefore bounded by edges. The striking or pressure platform of a core is also delimited by its edges. In the case of a bifacial tool, the word **ridge** is used.

ENDSCRAPER FRONT. A line of retouches on a flake, a blade or a blade-let, which

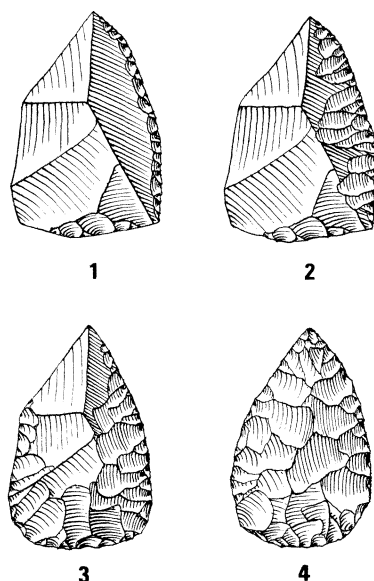

Fig. 67 — Extent of removals. 1 : short. 2 : long. 3 : invasive. 4 : covering.

form a scraper. Endscraper fronts can be described by adjectives pertaining to characteristics of **delineation**, of **angle** and of **morphology**.

EXTENT. A term describing the invasiveness of retouch removals (fig. 67). Irrespective of the proportions of each removal, the extent is said to be :

- short, if only a small surface on the edge is concerned,
- long,
- **invasive**, if it covers a large portion of the face,
- **covering**, if it affects the entire face.

The surface concerned by the extent of removals is likely to vary a great deal, thus giving rise to other adjectives than those suggested here.

F

FACE. Specific surfaces of a **blank**. The terms lower (ventral) face and upper (dorsal) face apply exclusively to flakes, blades and bladelets. The lower face (or fracture face) of a flake, blade or bladelet (as opposed to the upper face) is the positive surface resulting from the fracture of the raw material; it conjoins with a negative surface on the core, which includes the negative bulb (fig. 5). When traces of debitage can no longer be identified (*e.g.* on an entirely bifacial piece), or when the blank is other than a flake (slab, cobble, block, etc.), the faces will be arbitrarily referred to as "face A" or "face B", "face 1" or "face 2", etc.

FACETTED. A term for describing a **butt**, in which case the striking platform is prepared (fig. 62 : 4).

FIRST FLAKE (OPENING FLAKE). In theory, the first flake to be removed from a block of raw material (fig. 9 : 1, top left). A first flake always has a natural surface on the butt and the upper face. A single block of raw material can yield several independent first flakes

FLAKE. A general term for a fragment of hard stone that is removed :

- either from a core during its preparation (**preparation** flake, **preliminary** flake, etc.),

- or from a cobble, a slab, a core, etc., and if need be fashioned into a tool at a later stage (**knapping** flake, **debitage** flake),
- or from a tool during manufacture (**re-touch** flake, **shaping** flake).
The use of the word "flake" does not imply a particular morphology, a specific use, or particular dimensions (fig. 5).

FLAKED SURFACES. Fracture planes or surfaces formed by the removal of debitage products from cores. Flaked surfaces (or debitage surfaces) therefore consist of removal negatives bounded by arrises (fig. 20).

FLAKING ANGLE. The angle formed by the **butt** and the lower (ventral) **face** (fig. 5), as well as measurements taken of it. The examination of its morphology (presence of an incipient cone, or of a lip, etc.) will provide information about debitage techniques.

FLAT (PLAIN). A descriptive term particularly applied to **butts** (fig. 62 : 2).

FLUTED. A term that applies to pressure-flaked cores (fig. 31). The parallelism and the regularity of the arrises are evocative of the fluting of a Doric column¹³⁷. Fluted is also used as a synonym of **channel-flaked** in the case of Paleoindian projectile points.

FRACTURE. To divide into parts. Rocks can be caused to fracture by natural agencies (frost, surf, exposure to fire, etc.). The expression "intentional fracture" is used when it can be established that a **break** is not accidental, and refers to all known and unknown methods of dividing a piece of raw material into parts (see **knapping**), such as percussion, pressure, bending, sawing, the use of fire, etc.

FRACTURE FRONT. The fracture of raw materials obeys physical laws pertaining to solid objects. This implies the development of a crack, or fracture front, initiating from an impact point. Its importance for prehistorians lies in the characteristic marks (**ripples**, **hackles**) left on the lower face of a flake or on a negative of removal.

FRAGMENT. A piece broken off or detached. A fragment is identifiable, and can be assigned to a category of objects. The term should therefore not be used on its own, but qualified: blade fragment, flake fragment, handaxe fragment, tool fragment, etc. As debitage is the intentional fracture of a block of raw material (which becomes a core), any flake is a "core fragment". This last expression should therefore only be used in the case of a core broken by natural causes (internal joints, frost, fire, etc.).

G

GLOSS. A shiny surface condition. Gloss can have a natural origin (water, wind, friction due to vibration, etc.), or be artificial and due to wear, the best known example being the gloss on stone sickle-blades.

H

HACKLE. A fracture mark, which develops perpendicular to a **fracture front**, and therefore spreads radially from the impact point, during the separation of a flake (fig. 5). These marks are caused by the partial detachment of very small pieces of material. "Although quite narrow, they are wider at their starting points than at their extremities"¹³⁸. They are of variable dimensions, and are visible in negative (on cores, for instance) as well as in positive on the lower face of the flake. Hackles always converge on the impact point, thus allowing the identification of the direction of debitage in the absence of **ripples** and when the extremities are missing.

HAMMER. A natural implement used for knapping, shaping, or retouching hard stone. Hammers can be cobbles or lumps of stone, pieces of wood, antler, bone, ivory, etc (fig. 72). Convention has fixed the expressions "hammerstone" (or "hard hammer") for natural mineral hammers, and "soft hammer" for hammers of biological origin. Furthermore, some knapped objects, including discarded cores, were sometimes used as hammers.

¹³⁷ Tixier, 1963 : 43.

HEAT TREATMENT (THERMAL TREATMENT).

The flaking qualities (for debitage and re-touching) of some siliceous rocks can be improved by preliminary heat treatment, especially where pressure is used (fig. 1 : 7 and fig. 68). This technical advantage seems to have been discovered by the inventors of pressure-retouching and pressure debitage, some 15 to 20 000 years ago, in different parts of the world (p. 23-24).

HINGED. This describes any removal whose fracture plane, normal in its proximal zone, arches suddenly and intersects prematurely the upper face of the blank, which is therefore shorter than what was expected (fig. 7 : 1, and fig. 61 : 6). The exact opposite of this kind of accident is **plunging**.

I

IMPACT POINT. The point (in fact a small surface) where the blow is applied to fracture a piece of raw material. It is visible on the edge of the butt adjacent to the lower face. The **cone** and the **bulb** both develop from the impact point (fig. 5).

INDIRECT. Although this is the antonym of **direct**, the term is not used to denote a removal **position** (see **inverse**). It applies only to a **percussion** technique.

INDUSTRY. Broadly defined, the word “industry” describes human action applied to raw materials in order to transform them. It thus encompasses all activities aimed at producing useful objects. Mauss defined an industry as being “a set of techniques implying the use of different mechanisms towards a single goal”¹³⁹ or, for specialized industries, “as a set of techniques converging to satisfy a need, or more exactly, a consumer requirement [...] but it is this concept of consumption that permits the determination of the industries, systems

138 Dauvois, 1976. “[Ces stigmates] sont souvent assez étroits, plus larges à leur origine qu'à leur extrémité”.

139 Mauss, 1947 : 26. “un ensemble de techniques qui suppose l'emploi de machines différentes concourant à un même but”.

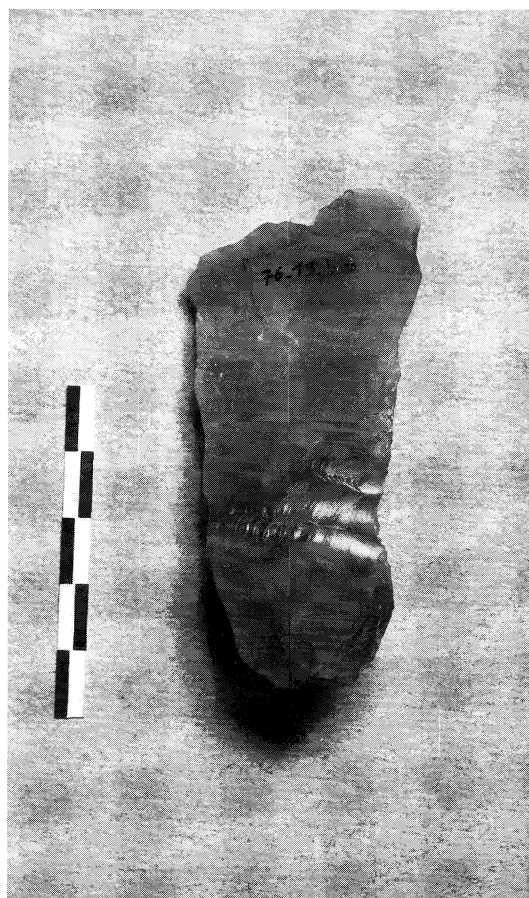

Fig. 68 — Thermally treated and subsequently pressure-retouched flint blade. Note the lustre on the three parallel removal negatives (Photo J. Tixier).

of techniques appropriate to objectives, organization of industries”¹⁴⁰.

The prehistorian gives a more restricted and concrete meaning to this word by strictly applying it to artefacts, and referring to bone and stone industries. Indeed, he must rely on objects made by prehistoric men in order to judge how they met their requirements and dealt with their problems of consumption.

INVASIVE. A term describing the **extent** of removals (fig. 67 : 3).

140 Mauss, 1947 : 41. “comme un ensemble de techniques concourant à la satisfaction d'un besoin - ou plus exactement à la satisfaction d'une consommation [...] mais c'est la notion de consommation qui permet de déterminer les industries, systèmes de techniques appropriés à des fins, agencement d'industries”.

INVERSE. A term defining a **position**. It refers to retouch removals stemming from the upper face, and can therefore only be applied to debitage products (flakes, blades, bladelets) (fig. 75 : 2).

J

JANUS (FLAKE). See **Kombewa**.

K

KNAPPING. A very general term, which includes any type of action aiming at the intentional **fracture** of hard rocks, according to the two main modes known, **percussion** and **pressure**. It is applicable in all cases, but is particularly relevant where the terms “debitage” and “retouching” cannot be used, and where no assumption can be made concerning the nature of the artefact (is it a tool or not?).

KNAPPING ACCIDENT. An unforeseen and unintentional incident occurring during flaking, shaping or retouching, and generating products with a specific although fortuitous morphology; also the outcome of this incident. Examples : **plunging** blade (fig. 7 : 5; fig. 74 : 1 to 3), “**Siret**” **accidental break** (fig. 80), **languette** (fig. 7 : 2 to 4), **nacelle** (fig. 7 : 5), etc.

KOMBEWA (FLAKE) or JANUS (FLAKE). A **flake** with two lower faces (fig. 27, 28).

KOMBEWA (METHOD). A method for obtaining a circular, semi-circular or elliptical flake. The shape is pre-determined by the convexity of the lower face of another flake, previously knapped to serve as a core (p. 68-69). An unretouched Kombewa flake thus possesses two lower faces¹⁴¹, which intersect (fig. 27, 28). Neither of these faces has arrises. The directions of percussion of the Kombewa flake thus obtained and of the flake used as a core can have any orientation relative to one another.

¹⁴¹ This is why Kombewa flakes have often been called “janus” flakes.

L

LANGUETTE. The term refers to a **knapping accident** and describes the specific morphology resulting from the unintentional fracture of a blade during debitage¹⁴² (fig. 7 : 2 to 4). The fracture wave appears to travel first along the surface of one of the faces before plunging suddenly, and then slanting out on the opposite face. *Languettes* can occur on the lower or upper face of a blade, they can be simple, or double and opposite. Such accidents are more common when direct percussion with a soft hammer or indirect percussion are applied, and less so when using a hard hammer or when pressure-flaking.

LEVALLOIS (METHOD). A special method of obtaining flakes (in the broader sense of the term). Their form is predetermined by the special preparation of cores prior to the removal of flakes (p. 61 to 68).

LINEAR. A term describing a particular shape of **butt** (fig. 62 : 9).

LIP. A slight projection of the ridge formed by the butt and the lower face can sometimes be observed on a flake. “In the bulb area, a countercurve topped by a kind of lip is formed where the fracture meets with the surfaces of the striking platform”¹⁴³ (fig. 62 : 8, profile). This morphology is characteristic of flakes removed by a soft hammer.

LOCALIZATION. A term describing the place occupied by removals on a piece, relative to an **orientation** (fig. 69). There are two possibilities :

1. the blank is a debitage product and therefore has a single conventional orientation; in this case alone can the terms **proximal**, **distal** and **mesial** (or central) be used;

2. any other blank (debitage products that cannot be conventionally oriented, cobbles, slabs, etc.), is arbitrarily oriented according to various criteria. The loca-

¹⁴² Bordes, 1970.

¹⁴³ Dauvois, 1976 : 168. “Au niveau du bulbe, la rencontre de la fracture avec les surfaces du plan de frappe du nucléus se fait suivant une sorte de lèvres, en contre-courbe”.

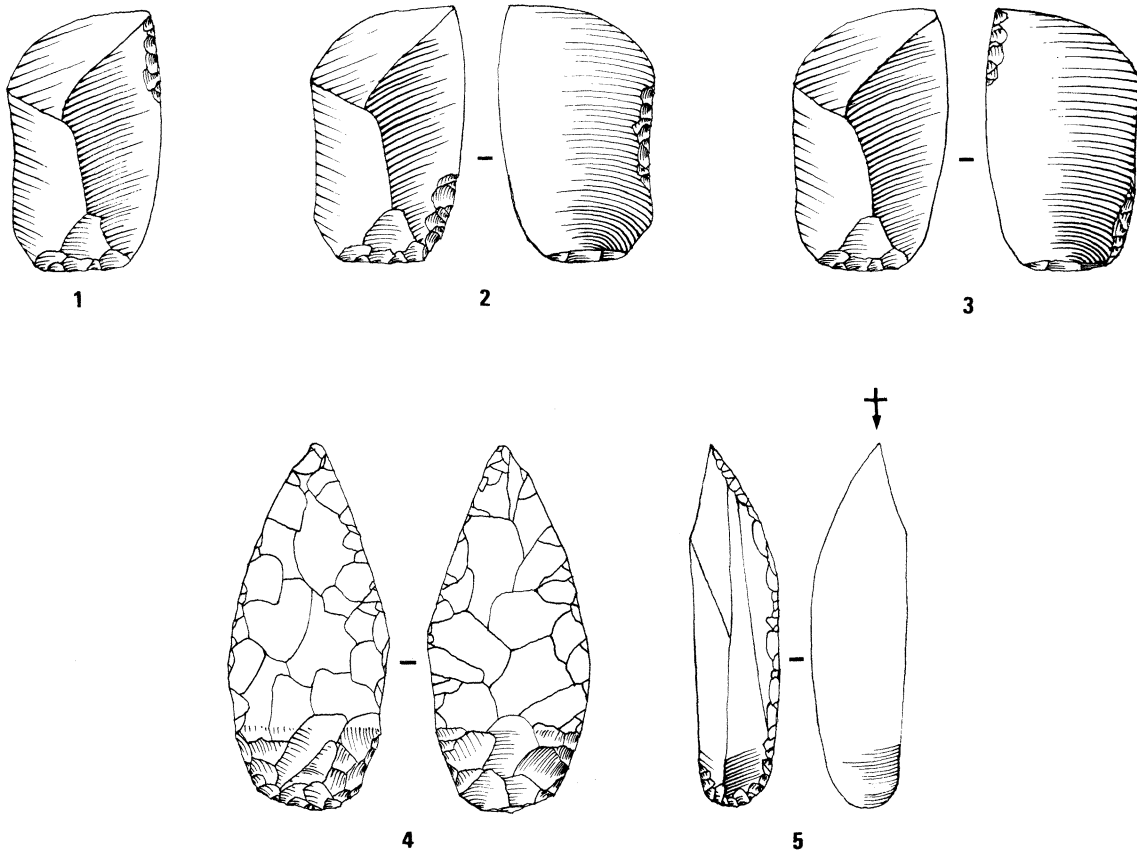

Fig. 69 — Localization of removals, various examples. 1 : distal right. 2 : proximal right and mesial left. 3 : distal right and proximal left. 4 and 5 : basal.

lizations and their denominations are therefore dependant on the different orientations.

In all cases the terms “right” and “left” are applied relative to the faces.

LOW ANGLE. Denotes the angle of removals (fig. 56 : 4).

M

MESIAL. An adjective of **localization**, referring to the middle section of a blank. The word “central” is also used (fig. 5).

METHOD. An orderly set of rational procedures devised for the purpose of achieving an end. The method followed to create a prehistoric tool is thus an orderly sequence of actions carried out according to one or more techniques, and guided by a rational plan.

MICROBURIN. *Distal microburin* : distal part of a flake, blade or bladelet detached by the microburin blow technique.

Proximal microburin : proximal part of a flake, blade or bladelet detached by the microburin blow technique.

Double microburin : central part of a blade or bladelet showing at both ends the characteristics of a microburin (fig. 33).

MORPHOLOGICAL AXIS. The axis of maximum symmetry of an object, in the direction of its greatest length¹⁴⁴, whether on a debitage product (retouched or not), a bifacial tool, a chopper, etc. This axis is relevant to problems of conventional **orientation**, and certain measurements are dependent upon its determination, whether the object is drawn or not. It is also used to

¹⁴⁴ Dauvois, 1976 : 24.

distinguish the types of certain tools, such as *déjeté* convergent scrapers (fig. 41 : 4), pseudo-Levallois points, etc.

MORPHOLOGY. A term conveying the idea of shape; *i.e.* the morphology of a tool, of a blank, of a core, of a removal, etc.

MORPHOLOGY OF RETOUCH REMOVALS.

The shapes of retouch removals are almost infinitely variable. The most widely used terms are (fig. 70) :

- **scaled** : wide, short removals, wider in their distal extremity than in their proximal extremity, and bearing a close resemblance to fish-scales¹⁴⁵, or more exactly to the imprint left by fish-scales; in their distal zone the flakes removed are slightly hinged, and this can be felt by running a finger-nail across the surface;
- **stepped** : removals showing similar, but far more pronounced characteristics, akin to a flight of steps¹⁴⁶; this implies a relatively thick blank;
- **parallel** : a series of removals separated by parallel arrises; there are many possibilities, which combine the length and the angle of series of removals when they are obtained by pressure : parallel transverse or oblique, chevron patterned, rippled¹⁴⁷, etc. (fig. 71);
- **sub-parallel** : a series of removals separated by arrises that are more or less parallel.

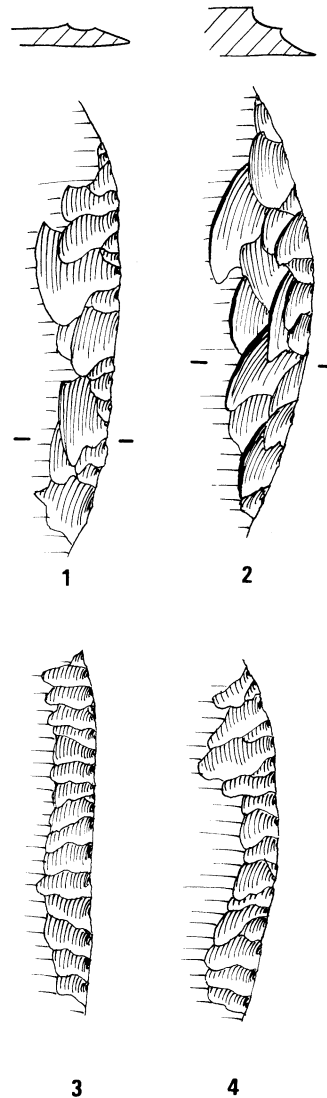

Fig. 70 — Morphology of removals. 1 : scaled. 2 : stepped. 3 : parallel. 4 : sub-parallel (Bordes, 1961 : fig. 2, 1).

N

NACELLE BREAK. A rather uncommon accidental fracture with a specific morphology, which can however occur quite frequently when pressure-flaking obsidian blades. It develops not very far from the butt. The fracture wave suddenly arches towards the upper face, removing part of the two edges, travels alongside the faces for a few millimeters, and intersects quite as suddenly the lower face. The *nacelle* is plainly visible on the lower face of the blade, and the small corresponding waste product also bears a specific morphology (fig. 7 : 5).

145 Bordes, 1961 : 8.

146 *ibid.*

147 These are known as “ripple-flakes” and refer to the Egyptian predynastic knives.

NEGATIVE BULB. Imprint or negative of the **bulb** of a flake (fig. 20).

NEGATIVE OF REMOVAL. By definition, the complementary surface of a **removal** created by the fracture of the raw material. Removal negatives are thus the scars visible on cores (fig. 20), on the upper faces of flakes (fig. 5), and on the retouches on all tools.

NOSE. A term of **delineation**, denoting a projection flanked by two **shoulders** (fig. 65 : 9).

NOTCH. A term describing the **delineation** of an edge, indicating a sharp dent, generally concave, sometimes V-shaped, with a small curvature radius, and created by various retouch techniques (fig. 34 : 4). See **Clactonian**.

O

OPENING FLAKE. See **first flake**.

ORIENTATION. The orientation of knapped stone objects is entirely a matter of convention. It can vary, depending on whether objects are being drawn or studied. See **debitage axis**, **morphological axis**, **localization** (fig. 41).

OVERHANG. A projection crowning a core. The **striking** or **pressure platform** overhangs the **negative bulbs** (fig. 20). Its **abrasion** signally eases debitage, especially in the case of direct percussion with a soft hammer. It is not, however, necessarily required for debitage by percussion with a hard hammer, or for pressure debitage. The presence or absence of an overhang therefore supplies useful information about the debitage or preparation techniques.

P

PARALLEL. A term describing the **morphology of removals** (fig. 70 : 3, fig. 71).

PARTIAL. A term applying to :

- the **distribution** of removals along an edge (fig. 66 : 3);
- bifacial tools not entirely knapped (partial biface).

PATINA. A natural alteration of the outer part of an object, after its intentional knapping. On a single object therefore, the patina always develops later than the **cortex**. A tool can show several patinas, which can demonstrate the sequence of transformation to which it has been subjected.

PECKING. The stone-cutter's pick-hammer (or pecker), a pointed hammer used for tooling the faces of a stone, is a modern instrument. "The pick-hammer is used for



Fig. 71 — Examples of oblique covering parallel retouch. Left : obsidian, J. Tixier. Right : Grand-Pressigny heat-treated flint, D.E. Crabtree. (Atelier photo C.N.R.S., Meudon).

crushing and levelling out the roughest edges of the stone”¹⁴⁸. When applied to a smooth surface, it has a reverse effect, producing small indentations. This action is known as pecking, and in archaeology the term refers to a technique that can be detected on artefacts bearing a pitted facing produced by a stone hammer. Pecking can be used for :

- blunting ridges and obtaining a rounded form, as in the shaping of spheroids and bolas (which should not be mistaken for hammerstones, although the difference is not always obvious, fig. 16 : 2, 3);
- for roughening surfaces, as in the case of grinding stones (querns and mortars), or, in more recent prehistoric times, for dressing building stones;
- for preparing a surface prior to polishing it;
- etc.

¹⁴⁸ Bessac, 1987 : 79. “La boucharde écrase ou égalise les plus grosses aspérités de la pierre”.

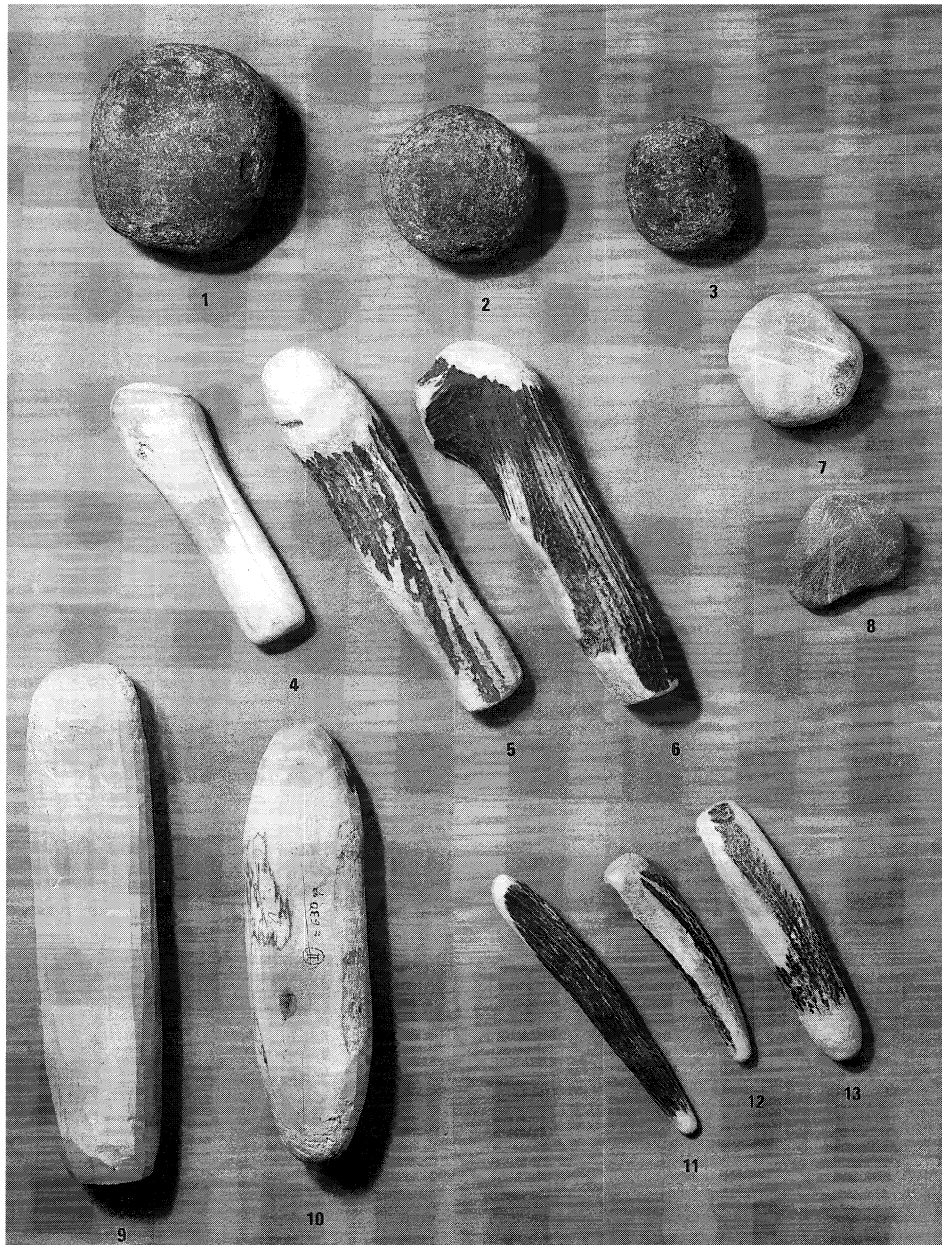

Fig. 72 — The stone-knapper's set of tools for percussion (J. Pelegrin). 1, 2, 3 : various hammerstones. 4, 5, 6 : antler billets. 7, 8 : small abrading sandstone pebbles. 9, 10 : wooden billets for direct or indirect percussion. 11, 12, 13 : antler punches (Atelier photo C.N.R.S., Meudon).

PERCUSSION. By definition, the action of striking one object with another. Of the two main techniques used for fracturing hard stone during prehistoric times, percussion was the first to appear and the only one in use for a very long period. It therefore refers to knapped, flaked, shaped, and re-touched objects.

Direct percussion (fig. 4 : 1, 2; fig. 72) is directly applied by a hammer. It is current-

ly impossible to distinguish an “active” (or mobile) hand-held hammer-stone from a “passive” (or immobile) one, as the traces they bear are identical.

Indirect percussion (fig. 4 : 3) involves an intermediate object (a **punch**) as well as a hammer. There is no indisputable evidence for the use of this technique during the Palaeolithic, in spite of what has repeatedly been claimed.



Fig. 73 — The stone-knapper's set of tools for pressure (J. Pelegrin). 1 : long crutch. 2 : contraption used for immobilizing the core during blade debitage. 3 : short crutch for bladelet debitage or for retouching. 4 : wooden grooved device. 5 : hand-held grooved device. 6 : flat sandstone pebble (used for abrading the edge of the pressure platform). 7, 8, 9 : antler tools for pressure debitage or retouching in the hand.

PIQUANT-TRIÈDRE. The traces visible on the extremity of a blade or bladelet when part of it has been removed by the **microburin blow technique** (fig. 33). In addition to part of a notch (whose removals always stem from the lower face¹⁴⁹), the “*piquant-trièdre*” is characterized - as the name suggests - by a sharp extremity with three flat faces :

- (1) part of the lower face of the flake, blade or bladelet.
- (2) part of the upper face of the flake, blade or bladelet.

149 Allowing for very few exceptions, which can be disregarded : microburins obtained by applying blows to the upper face can be counted on the fingers of one hand throughout the world.

(3) the characteristic surface left by the removal of the microburin.

We have given preference to this term, coined by E.-G. Gobert¹⁵⁰, over the rather vague “oblique point” commonly used by other French prehistorians and coined by L. Siret¹⁵¹. The term “*piquant-trièdre*” can however be criticized for not highlighting the microburin blow technique, the latter term being altogether unsatisfactory.

PLAIN. See **flat**.

PLUNGING. This denotes any **removal** whose fracture plane, although normal in its proximal zone, arches sharply forward

150 Gobert, 1955 : 229.

151 Siret, 1924 : 123, caption of figure 6.

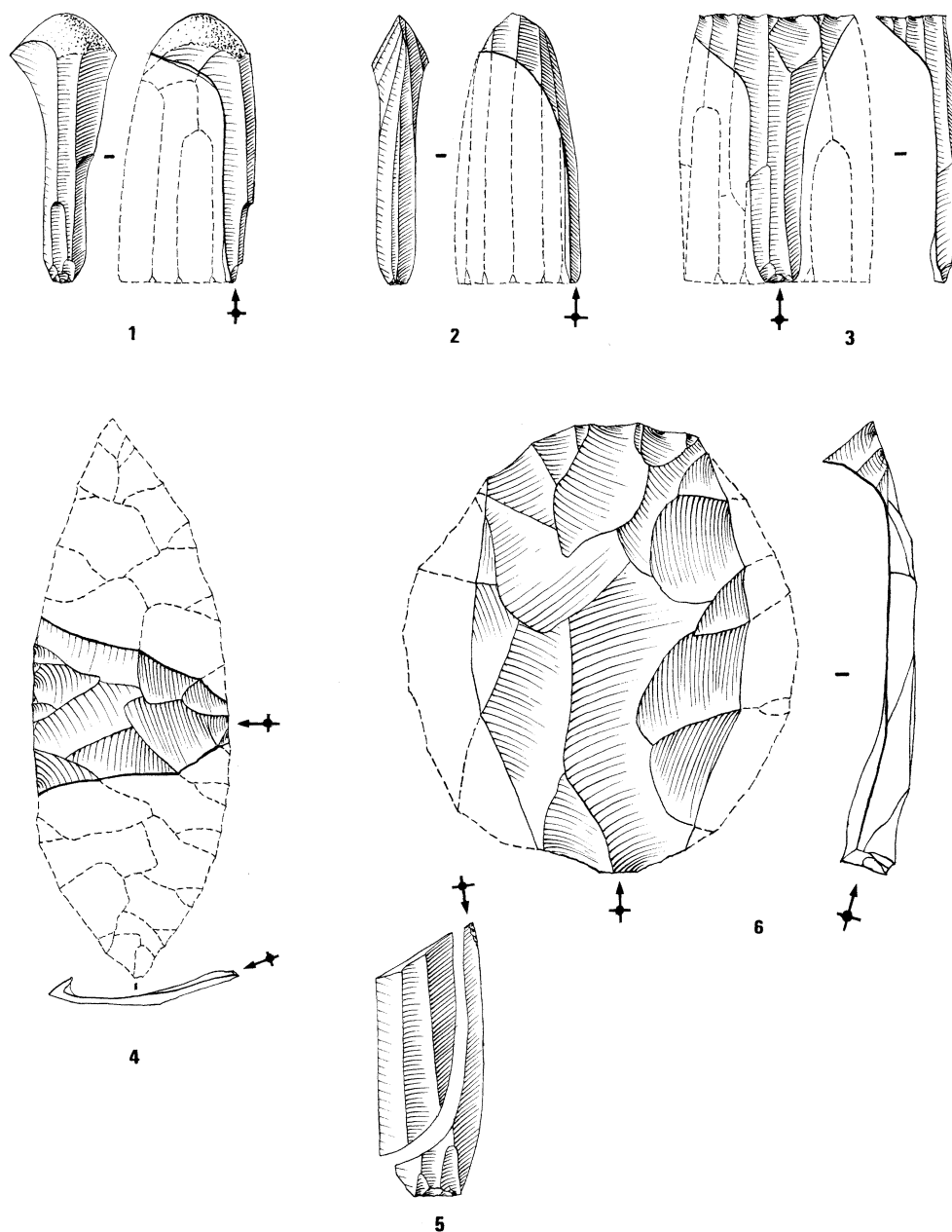

Fig. 74 — Various examples of plunging blades and flakes. 1 : on a core with a cortical end. 2 : on a pyramidal pressure core. 3 : on a core with two opposite striking platforms. 4 : on a bifacial foliate piece. 5 : plunging burin spall. 6 : plunging Levallois preferential flake.

and tears away a whole section of the blank, be it a core, a debitage product or a tool. A very concave lower face and a generally distal thickening are the two characteristics of plunging. Plunging can remove (fig. 74) :

- part of the cortical cap of a core at the beginning of debitage ;
- the apex of a pyramidal core ;

- part of the opposite striking platform on a core with two striking platforms ;
- on a Levallois core, part of the preparation opposite to the striking platform ;
- the end of a burin opposite to that where the burin blow has been applied ;
- part of the opposite edge on a bifacial piece ; etc.

Whether plunging is accidental or intentional such removals always provide information about the methods and techniques used. Any one who has experimented with knapping will have realised this sooner or later.

POLISH. The polish (smooth and shiny appearance) of a piece can be achieved by various means, whether intentional (see **polishing**) or not (p. 91).

POLISHING. The finishing of a shaped tool, or the preparation of a piece by friction against an active or passive polisher, with or without an abrasive. Polishing is thus the result of intentional action.

POSITION. A word referring to the position of removals relative to the faces of an object (fig. 75); these can be :

- **direct**
- **inverse**
- **alternate**
- **alternating**
- **bifacial**
- **crossed.**

PREFORM. A term defined by D.E. Crabtree¹⁵² to describe a bifacial piece that has been shaped (usually by percussion) to allow it to be finished by pressure-retouching or channel-flaking. The word preform is therefore used when referring to a piece that has been shaped or prepared with a view to undergoing a final series of operations involving one or more techniques (pressure-retouching, pecking, polishing), which differ from those used for shaping or preparation (fig. 18). For very elaborate pieces, the preform stage normally follows the **roughout** stage, and comes immediately before the finishing stage.

PRELIMINARY FLAKING. The initial series of operations carried out on a natural block (including cortex removal) in order to prepare it before undertaking to :

- rough out a tool;
- shape out a core (fig. 10 : 1).

PREPARATION. Any work prior to **debitage**, or any systematic retouching carried out to improve the chances of

success, can be referred to as preparation. For instance, a crest is prepared on a core (fig. 64), the edge of a blank is prepared to receive a burin blow (fig. 76 : 2b), an edge is prepared prior to being retouched, a preform is prepared by (pre-) polishing in order to obtain long parallel pressure retouches, etc. The confusion between preparation and retouching, and therefore between tools and waste products, can only be avoided through the reconstitution of the exact chronological sequence of technical actions.

PRESSURE. Unlike **percussion**, this method of fracturing hard stone is carried out with a tool whose extremity applies pressure to detach a **flake** (fig. 73). Pressure can be used for **debitage** (fig. 4 : 5, and fig. 30), or for retouching (fig. 4 : 6).

PRESSURE PLATFORM. The part of a core to which pressure is applied in order to detach flakes, blades, or bladelets. Pressure platforms are often prepared (fig. 31), but can also be flat (fig. 32) or natural surfaces.

PROXIMAL. An adjective of **localization** (fig. 69 : 2) qualifying the end of the blank that bears the butt-and-bulb part. (fig. 5). Applies only to **debitage** products (flake, blade, bladelet).

PUNCH. An object interposed between the striking platform of a core and the hammer. Experiment has shown that this knapping technique, called indirect percussion, can be used for the shaping out of cores, for the rejuvenation of striking and pressure platforms, for bifacial shaping, and especially for blade **debitage** (fig. 4 : 3). This object can be of stone, wood, bone, horn, antler, ivory or metal (fig. 72 : 11 to 13).

PUNCTIFORM. A term restricted to a particular morphology of the **butt** (fig. 62 : 10).

R

REFIT. A complete series of **conjoining** sets, which belong to same block of raw material (a core and its **debitage** products for instance) (fig. 36 and 40).

¹⁵² Crabtree, 1966.

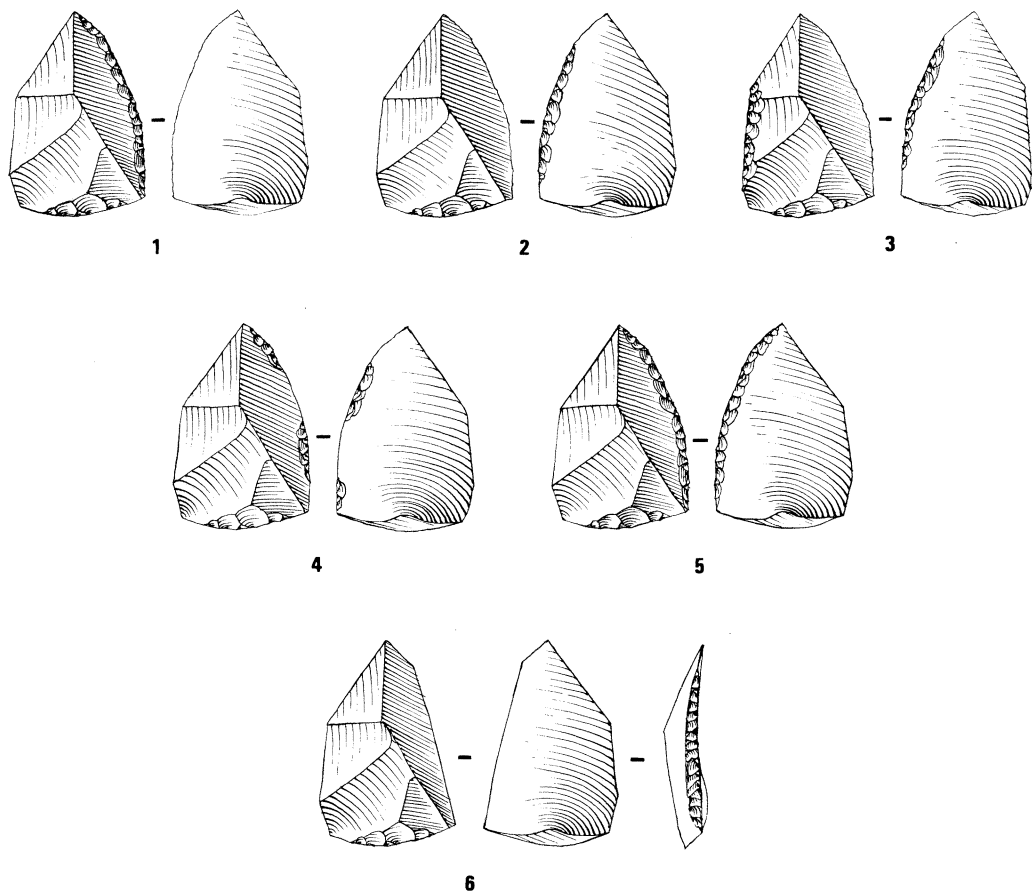

Fig. 75 — Position of removals. 1 : direct. 2 : inverse. 3 : alternate (being here direct on the left edge and inverse on the right edge). 4 : alternating. 5 : bifacial. 6 : crossed.

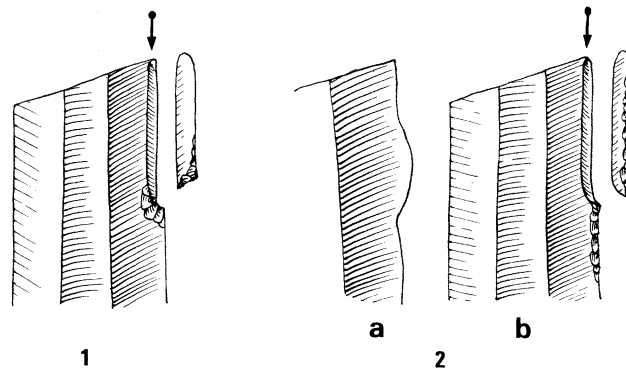

Fig. 76 — Examples of preparation. 1 : notch for stopping a burin spall. 2a : irregular unretouched blade edge. 2b : preparatory straightening of the edge prior to the removal of a burin spall.

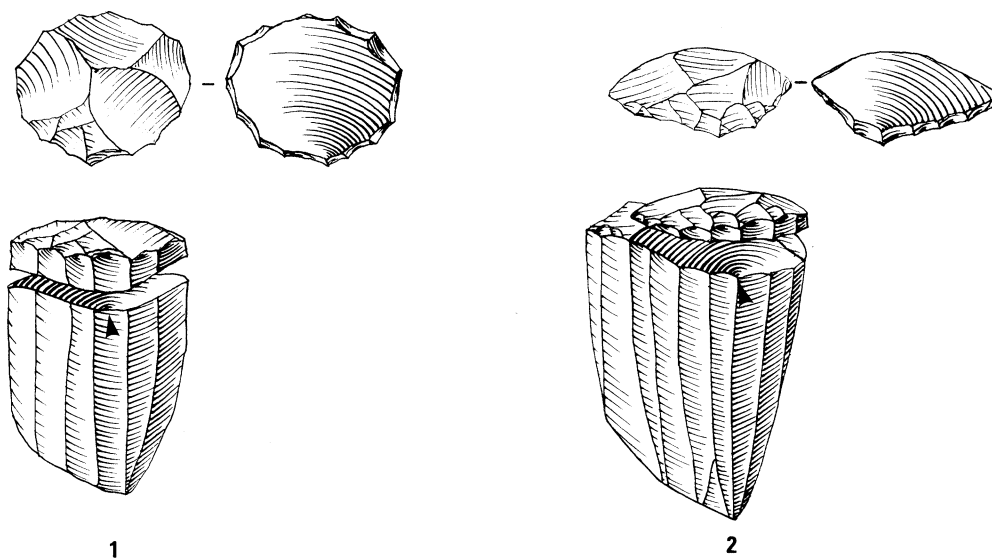

Fig. 77 — Core tablet and rejuvenation flake. 1 : total rejuvenation of a striking or pressure platform achieved through the removal of a core tablet. 2 : partial rejuvenation of a striking or pressure platform requiring only the removal of a flake.

REJUVENATION. A general term, which describes the action of making an edge or a ridge sharper, of rejuvenating a surface.

The term applies particularly to a preparation of the core during debitage, which may become necessary when the condition of the striking or pressure platform precludes the debitage from being continued. The operation consists in removing the striking or pressure platform, by means of a single thick removal (**rejuvenation core tablet**) (fig. 77 : 1), or of several thinner rejuvenation flakes (fig. 77 : 2), stemming from the flaked surfaces.

REJUVENATION CORE TABLET. A flake characteristic of the renovation of the striking or pressure platform of a core¹⁵³. The upper face of a first rejuvenation core tablet thus shows the negative marks of the preparation of a striking or pressure platform, and the butt consists of part of the flaked surfaces (fig. 77 : 1). It is sometimes necessary to remove a second flake of the same type. Its upper face thus shows the removal negative of the first rejuvenation core tablet, and the butt also consists of part of the flaked surfaces. This accounts for the often thick edges of rejuvenation core tablets,

and for their polygonal shape. In some industries, the Omalian¹⁵⁴ for instance, rejuvenation core tablets are as a rule repeatedly removed on blade cores.

REMOVAL. 1. A general term denoting the action of removing part of a hard stone during intentional flaking.

2. For the sake of convenience, the term also denotes **negative** traces left by this action.

RETOUCH. A retouch is a removal or a series of specific removals carried out for the purpose of obtaining a tool. Retouching is thus the structuring, sculpting and intentional transformation of a blank, whether or no this blank be a debitage product. The retouches - or retouch - are the marks left by this action. A retouch can be defined by a set of characteristics (ch. 5).

RESHARPENING. See **sharpening**.

RIDGE. A general morphological term, which denotes the intersection of several surfaces (especially two) forming dihedral angles. For instance the ridge of a handaxe, the ridge of a crest, etc.

153 Hamal Nandrin, Servais, 1921.

154 Cahen *et al.*, 1979.

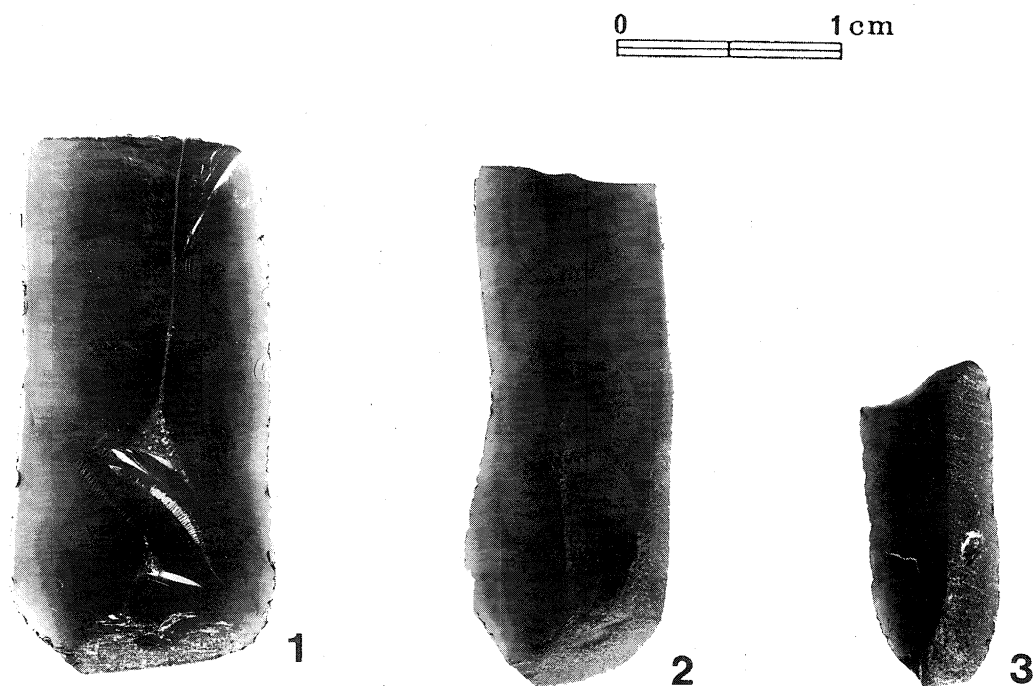

Fig. 78 — Proximal fragments of pressure-flaked obsidian bladelets, showing more (2, 3) or less (1) invasive traces of rubbing down on their upper faces, Obeid, Tell el Oueili, Irak.

RIPPLES. Concentric waves of variable length and amplitude spreading from the impact point, and resulting from the propagation of the fracture front; they are often visible on the lower faces of flakes, and can also be observed on the removal negatives (fig. 5). In the absence of the butt/bulb part, they indicate the direction of knapping.

Note : ripples may not be perceptible on very homogeneous, non-vitreous raw materials, and direction of knapping may be impossible to determine on heterogeneous raw materials owing to distorted ripples. In all cases, **hackles** remain the most relevant clues to the orientation of debitage products.

ROUGHOUT. Rough and still imperfect form given to a three-dimensional artefact. This term is used almost exclusively for bifacial tools obtained through **shaping**. Sound arguments, entailing an in-depth technological analysis, are necessary to demonstrate that an object is yet uncompleted, and is therefore still a roughout. In the past, such objects have been very rashly interpreted.

RUBBED DOWN. Applies to surfaces worn off through abrasion. Refers specifically to a technique used on some obsidian cores to prepare the pressure platform, and thus prevent the tool from slipping on the vitreous rock during debitage (fig. 78). It is widely documented in Central America for the Prehispanic period, and is also known in the East and the Far East (Yubetsu and Shirataki methods from Japan, etc.).

S

SCALED. A term describing the **morphology** of removals (fig. 70 : 1).

SECTION. A section is the representation of the virtual surface created by a plane sectioning an object (fig. 44c), whereas a section view represents the parts of the object situated both at and behind the sectioning plane (fig. 44b).

SEMI-ABRUPT. A term referring to the **angle of retouch** or removal (fig. 56 : 3).

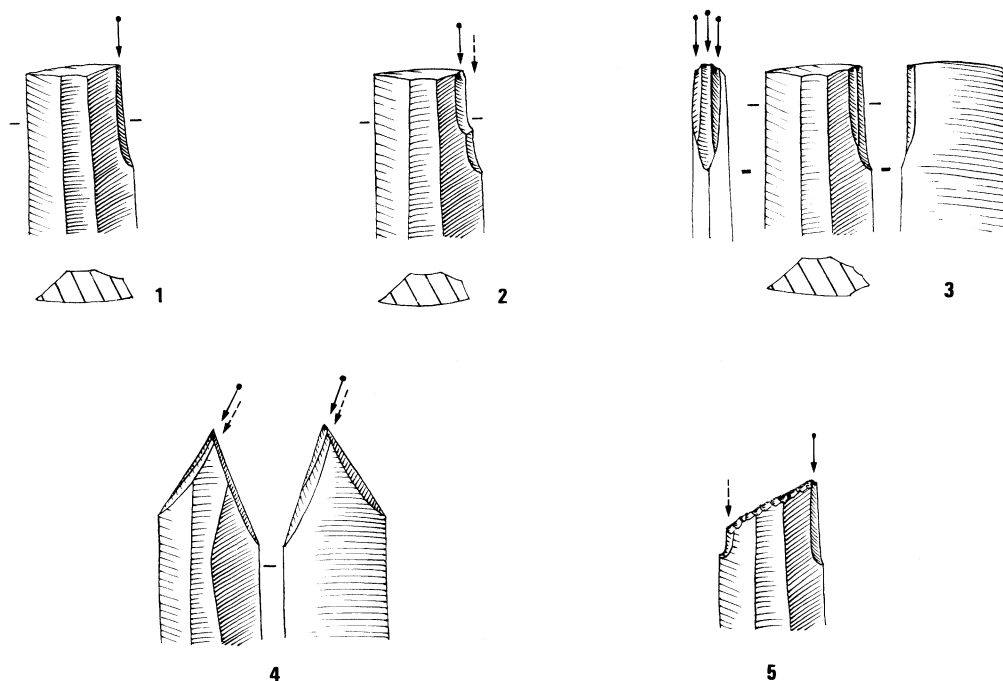

Fig. 79 — Various examples of sharpening on simple burins. 1 : burin with a single burin facet, no visible sharpening. 2 : sharpening by successive burin blows on the same point. 3 : sharpening by parallel removals. 4 : sharpening on both burin facets of a dihedral burin. 5 : sharpening by truncation and application of a new burin blow on the opposite edge.

SHAPING. Shaping is a knapping operation carried out for the purpose of manufacturing a single artefact by sculpting the raw material in accordance with the desired form. In archaeology, the term applies to the manufacture of bifacial, polyhedral, trihedral pieces, etc., whatever the nature of the blank and the size of the finished product. Shaping generally involves two successive phases, roughing out and finishing, and can bring into play a number of techniques. Unlike debitage, the purpose of the operation is not to obtain blanks - although shaping often produces a high number of flakes - but to transform any type of blank into a tool.

SHAPING OUT. The expression refers to the last operation that gives a core its final shape immediately prior to debitage proper. For instance, an unflaked Levallois core, or a blade core still possessing its crest(s) (fig. 10 and fig. 64 : 1).

SHARPENING or RESHARPENING. This term should only be applied to the rejuvenation of a tool by the same method used to create

the original. If a different method has been used, the type of tool is transformed¹⁵⁵. Indisputable traces of sharpening can subsist on some tools, such as burins (fig. 79 : 3, 4, 5).

Further information is provided by characteristic flakes, and direct proof by **conjoins** and **refits**.

SHARPENING SPALL. See **burin spall**.

SHOULDER. The French *cran* and *épaulement*, terms describing the **delineation** of an edge, are both translated by “shoulder”. *Cran* implies a regular line of removals, which cuts sharply into an edge, and then curves along the edge to its very end (fig. 65 : 7). *Epaulement* implies a regularly curved line of removals, associating a concavity with a convexity (fig. 65 : 8). The principle is the same, but *épaulement* is

¹⁵⁵ Thus, a burin on the retouched edge of a backed blade can easily be transformed into a dihedral burin on a backed blade.

conventionally applied to “the fashioning of the active part of the tool”¹⁵⁶.

“SIRET” (ACCIDENTAL BREAK). “The so-called ‘Siret’ burin¹⁵⁷ should be laid to rest once and for all, as it is nothing but a knapping accident. It sometimes happens that during the separation of a flake two perpendicular flaking planes develop, the second one separating the flake into two more or less equal parts”¹⁵⁸ (fig. 80). This type of accidental break is common in flakes removed with a hard hammer. It occurs less commonly in blades, as well as when a soft hammer is used or when indirect percussion is applied. The frequency of its occurrence is also linked to the quality of the raw material. For instance it is very common in the case of coarse-grained quartzites (Fontainebleau quartzite, Brazilian silicified arenite), or coarse-grained volcanic rocks lacking in homogeneity (East African phonolite).

SKETCH. A free hand drawing, rendering the main features of the object with just a few strokes. It comes before the final drawing, of which it is the foundation (fig. 45).

SPONTANEOUS REMOVALS. The expression “spontaneous retouch” was coined in 1976 by M. Newcomer¹⁵⁹ to describe removals that occur within a fraction of a second after the detachment of a flake, which cannot fall free as the core is pressed against the hand, foot, or thigh of the knapper. These removals are due to the pressure of the flake against the core. They are quite unintentional, and are thus referred to as spontaneous removals.

SPUR. A term restricted to a **faceted butt** morphology (fig. 62 : 8).

156 Brézillon, 1968 : 124. “... au dégagement de la partie active”.

157 Siret, 1933.

158 Bordes, 1961 : 32. “Il convient d’exécuter une fois pour toutes le burin dit ‘de Siret’ qui n’est qu’un accident de taille. Il arrive parfois que, lors du détachement d’un éclat, deux plans d’éclatement perpendiculaires se produisent, le second séparant l’éclat en deux parties plus ou moins égales”.

159 Newcomer, 1976.



Fig. 80 — “Siret” accidental break : snapping in two of a flake along the percussion axis. (Atelier photo C.N.R.S., Meudon).

STEPPED. A term describing the **morphology** of removals (fig. 70 : 2, and fig. 34 : 6).

STRIKING PLATFORM. The part of a core that is struck, using **percussion**, in order to detach a flake, blade or bladelet. A striking platform can be a natural, flat, or prepared surface (fig. 20).

SUB-PARALLEL. A term describing the **morphology** of removals (fig. 70 : 4).

T

TANG. A term of **delineation**, which refers to a projection outlined by two flanking **notches** or **shoulders** (fig. 65 : 11, 12); long narrow tang (fig. 65 : 13).

TECHNIQUE. A technique being the practical manner of accomplishing a

particular task, we define a “technique” as one of the procedures of a craft (and sometimes of an art) : that of the prehistoric knapper.

Examples of techniques are : direct percussion with a hammerstone, the debitage of a blade by pressure-flaking, and the fracture of a bladelet by means of the microburin blow.

A **method** of knapping is arrived at by the rational linking together of an orderly sequence of actions, carried out according to one or more techniques.

THERMAL TREATMENT. See **heat treatment**.

TONGUE. A term of **delineation**, which refers to the fashioning by regular removals of a tongue-shaped protuberance on the extremity of a tool¹⁶⁰ (fig. 65 : 10).

TOOL. Some knapped stones were certainly tools¹⁶¹ or tool components, others were weapons or weapon components. Conventionally, and for simplicity’s sake, the word “tool” encompasses both tools and weapons, as it is usually impossible to prove whether it belongs to either one or the other of these two categories. The term applies to any artefact that has indubitably been used, irrespective of its surmised function. This includes pieces made on knapped blanks (*e.g.* endscraper on blade) or on natural blanks (*e.g.* scraper on slab); unretouched pieces whose function can be demonstrated by microwear analysis (*e.g.* flakes used for cutting meat¹⁶²); natural “objects” modified by macro- or microscopic traces of wear or hafting; retouched or unretouched pieces bearing traces of intentional gloss; tools used for making stone tools (*e.g.* hammer, pecker, punch, etc.).

TRANCHET BLOW TECHNIQUE. A technique that involves the removal of a flake from one extremity of certain Palaeolithic and Neolithic bifacial pieces (fig. 34 : 1), in

order to obtain an unretouched terminal cutting edge. A variant of this method produces a lateral cutting edge, seen on a number of Acheulean handaxes from western Europe. This has been called the “lateral tranchet blow”¹⁶³ (fig. 34 : 2).

TRIMMED EDGE. This expression should be used when describing the modified part of a cobble¹⁶⁴, a block or a slab, as no assumption is thereby implied concerning the nature of the artefact or its function.

TRUNCATION. A line of regular continuous retouches, almost always abrupt, truncating either the proximal, distal or lateral part of a flake, blade or bladelet, and forming two angles with the edges of the blank to which it is applied. As the term truncation necessarily implies “retouched”, it is pointless to add this epithet.

U

UNMODIFIED. Refers to the raw material in its original unworked / untreated state, before any human intervention.

UNRETOUCHED. This term describes all or part of a **debitage product** (flake, blade, or bladelet) not modified by retouching.

V

VERSANT. This term is used to denote the two surfaces that limit the ridge of a crest on a core, or on the upper face of a crested blade. At least one of them must bear the negatives of removals left by the preparation or the shaping out of a core (fig. 64 : 5).

W

WINGED. An expression used only for a **butt** morphology (fig. 62 : 6).

¹⁶⁰ Gobert, 1950 : 23.

¹⁶¹ Mauss, 1947.

¹⁶² Audouze, 1988 : 110.

¹⁶³ Zuate y Zuber, 1972.

¹⁶⁴ Roche, 1980.

Bibliography

- AKAZAWA T., ODA S., YAMANAKA I.
1980 The Japanese Palaeolithic : a technological study. Tokyo : Rippu Shobo.
- ALIMEN M.-H.
1978 *L'évolution de l'Acheuléen au Sahara nord-occidental (Saoura, Ougarta, Tabelbala)*. Meudon : C.N.R.S.
- ANDERSON P.C. (ed.)
1992 *Préhistoire de l'agriculture : nouvelles approches expérimentales et ethnographiques*. Paris : C.N.R.S. (*Monographie du C.R.A.* ; 6).
- ANDERSON P.C., INIZAN M.-L.
1994 Utilisation du tribulum au début du III^e millénaire : des lames "cananéennes" lustrées à Kutan (Ninive V) dans la région de Mossoul, Iraq. *Paléorient*, 20, 2 : 85-103.
- AUDOUZE F.
1988 Les activités de boucherie à Verberie (Oise). In : *Technologie Préhistorique* : 97-111. Paris : C.N.R.S. (*Notes et Monographies Techniques* ; 25).
- AUDOUZE F., CAHEN D.
1982 Décryptage d'un habitat magdalénien de plein air. In : *Les habitats du Paléolithique supérieur*, 2 : 210-220. Prépublication du colloque international en hommage au Pr André Leroi-Gourhan à Roanne-Villerest.
- BALOUT L.
1967 Procédés d'analyse et questions de terminologie dans l'étude des ensembles industriels du Paléolithique inférieur en Afrique du Nord. In : *Background to evolution in Africa*. Bishop W.W., Clark J.D. (eds) : 707-736. Chicago and London : The University of Chicago Press.
- BALOUT L., BIBERSON P., TIXIER J.
1967 L'Acheuléen de Ternifine. *L'Anthropologie*, 71 : 217-237.
- BESSAC J.-C.
1987 L'outillage traditionnel du tailleur de pierre de l'Antiquité à nos jours. Paris : C.N.R.S. (*Revue Archéologique de Narbonne*. Supplément : n° 14).
- BEYRIES S.
1993 Are we able to determine the function of the earliest palaeolithic tools? In : *The use of tools in human and non-human primates*. Berthelet A., Chavaillon J. (eds) : 225-236. Oxford : Clarendon Press (Fyssen Foundation Symposium).
- BIG PUZZLE (THE)**
1980 *International symposium on refitting stone artefacts*, Monrepos 1987. Czesla E., Eickhoff S., Arts N., Winter D. (eds). Bonn : Holos (*Studies in Modern Archaeology* ; 1).
- BINDER D.
1984 Système de débitage laminaire par pression : exemples chasséens provençaux. In : *Economie du débitage laminaire* : 71-84. Paris : C.R.E.P. (*Préhistoire de la pierre taillée* ; 2).
- BOËDA E.
1988 Le concept laminaire : rupture et filiation avec le concept Levallois. In : *L'Homme de Néandertal, 8 : la mutation*. Otte M. (ed.). Actes du Colloque International de Liège, 1986 : 41-49. Université de Liège (*E.R.A.U.L.* ; 35).
- BOËDA E.
1994 *Le concept Levallois : variabilité des méthodes*. Paris : C.N.R.S. (*Monographie du CRA* ; 9).
- BOKSENBAUM M.W.
1977 Some comments on classification. *Lithic Technology*, VI, 3 : 28-30.
- BOLETIN DE ANTROPOLOGIA AMERICANA**
1982 Vol. 6. Mexico : Instituto panamericano de geografia e historia.
- BORDES F.
1947 Etude comparative des différentes techniques de débitage et de la typologie du Paléolithique ancien et moyen. *L'Anthropologie*, 51 : 1-29.
- BORDES F.
1961 *Typologie du Paléolithique ancien et moyen*. Bordeaux : Delmas.

- BORDES F.
1967 Considérations sur la typologie et les techniques dans le Paléolithique. *Quartär*, 18 : 25-55.
- BORDES F.
1969 Traitement thermique du silex au Solutréen. *C.R.S.M. du Bull. de la Société Préhistorique Française*, 66, 7 : 197.
- BORDES F.
1970 Réflexions sur l'outil au Paléolithique. *C.R.S.M. du Bull. de la Société Préhistorique Française*, 67, 7 : 199-202.
- BORDES F.
1975 Le gisement du Pech de l'Aze IV : note préliminaire. *Bull. de la Société Préhistorique Française*, 69, *Etudes et Travaux* : 293-308.
- BORRADAILE G.J., KISSIN S.A., STEWART J.D., ROSS W.A., WERNER T.
1993 Magnetic and optical methods for detecting the heat treatment of chert. *Journal of Archaeological Science*, 20 : 57-66.
- BOURLON M.
1911 Essai de classification des burins : leurs modes d'avivage. *Revue anthropologique*, XXI : 267-278.
- BRAIDWOOD
1961 The general appearance of obsidian in South Western Asia and the microlithic side-blow blade flake in obsidian. In : *V^o International Kongress für Vorund Frühgeschichte, Hamburg (1958)* : 142-147. Berlin, Verlag Gebr. Mann.
- BREUIL H.
1909 Etudes de morphologie paléolithique. I. Transition du Moustérien vers l'Aurignacien à l'Abri Audi (Dordogne) et au Moustier. *Revue de l'Ecole d'Anthropologie de Paris*, XIX : 320-340.
- BREUIL H.
1932 Les industries à éclats du Paléolithique ancien. I. Le Clactonien. *Préhistoire*, I, 2 : 125-190.
- BREZILLON M.N.
1968 *La dénomination des objets de pierre taillée. Matériaux pour un vocabulaire des préhistoriens de langue française*. Paris, C.N.R.S. (*Gallia Préhistoire*, IV^e supplément).
- BRUGAL J.-P., BUISSON-CATIL J., CREGUT-BONNOURE E., FRANCISCO-ORTEGA I., GUERIN C., JAUBERT J., LEBEL S., TEXIER P.-J.
1994 Diversité et complémentarité des principaux gisements vauclusiens. In : *Le Paléolithique moyen en Vaucluse. A la rencontre des chasseurs néandertaliens de Provence nord-occidentale*. Buisson-Catil J. (ed.), Avignon, Service d'archéologie de Vaucluse : 71-125 (*Notices d'Archéologie Vauclusienne*; 3).
- CAHEN D.
1984 Technologie du débitage laminaire. In : *Les fouilles de la place St-Lambert à Liège*, 1 : 171-197. Université de Liège (*E.R.A.U.L.*; 18).
- CAHEN D.
1987 Refitting stone artefacts : why bother? In : *The human uses of flint and chert*. Sievekind G. de G., Newcomer M.H. (eds). Proceedings of the Fourth International Flint Symposium held at Brighton Polytechnic, 10-15 april 1983 : 1-10. Cambridge : Cambridge University Press.
- CAHEN D., DEMAREZ L., VAN BERG P.-L.
1979 Néolithique rubané de faciès omalien à Blicquy. *Archeologia Belgica*, 213 : 25-29.
- CAHEN D., KARLIN C., KEELEY L.H., VAN NOTEN F.
1980 Méthodes d'analyse technique, spatiale et fonctionnelle d'ensembles lithiques. *Helinium*, 20, 3 : 209-259.
- CAUVIN J.
1971 A propos des nucléus Levallois de Beqa (Liban). *C.R.S.M. du Bull. de la Société Préhistorique Française*, 68, 3 : 89-90.
- CHIERICI G.
1875 Le selci romboïdali. *Bull. Paletnol. ital.*, I.
- CLARK J.D., KHANNA G.S.
1989 The site of Kunjhun II, middle Son valley and its relevance for the Neolithic of Central India. In : *Old problems and new perspectives in the archaeology of South Asia*. Kenoyer J.M. (ed.) : 29-46. Madison : University of Wisconsin (*Wisconsin Archaeological Reports*; 2).
- COINEAU Y.
1978 *Comment réaliser vos dessins scientifiques ?* Paris : Gauthiers-Villars.

- CRABTREE D.E.
1966 A stone worker's approach to analysing and replicating the Lindenmeier Folsom. *Tebiwa*, 9, 1 : 3-39. Pocatello : Idaho State University Museum.
- CRABTREE D.E.
1967 Notes on experiments in flintknapping : 3. The flintknapper's raw materials. *Tebiwa*, 10, 1 : 8-24. Pocatello : Idaho State University Museum.
- CRABTREE D.E.
1968 Mesoamerican polyhedral cores and prismatic blades. *American Antiquity*, 33, 4 : 446-478.
- CRABTREE D.E.
1972 An introduction to flintworking. *Occasional Papers of the Idaho State University Museum*, 28 : 1-98. Pocatello : Idaho State University Museum.
- CRABTREE D.E.
1973 Experiments in replicating Hohokam points. *Tebiwa*, 16, 1 : 10-42. Pocatello : Idaho State University Museum.
- CRABTREE D.E., BUTLER R.
1964 Notes on experiments in flintknapping : 1, heat treatment of silica materials. *Tebiwa*, 10, 1 : 8-24. Pocatello : Idaho State University Museum.
- CRESSWELL R.
1989 L'unité fondamentale. In : *André Leroi-Gourhan ou Les Voies de l'Homme*. Actes du colloque du C.N.R.S., mars 1987. Paris : Albin Michel.
- DAUVOIS M.
1976 *Précis de dessin dynamique et structural des industries lithiques préhistoriques*. Périgueux : Fanlac.
- DAUVOIS M.
1981 De la simultanéité des concepts Kombewa et Levallois dans l'Acheuléen du Maghreb et du Sahara nord-occidental. In : *Mélanges à L. Balout. Préhistoire Africaine* : 313-321. Paris : A.D.P.F.
- DEMARS P.-Y.
1982 *L'utilisation du silex au Paléolithique supérieur : choix, approvisionnement, circulation. L'exemple du Bassin de Brive*. Paris : C.N.R.S. (*Cahiers du Quaternaire*; 5).
- DOMANSKI M., WEBB J.A.
1992 Effect of heat treatment on siliceous rocks used in prehistoric lithic technology. *Journal of Archaeological Science*, 19 : 601-614.
- ECONOMIE DU DEBITAGE LAMINAIRE*
1984 Paris : C.R.E.P. (*Préhistoire de la pierre taillée*; 2).
- FEBLOT-AUGUSTINS J.
1997 *La circulation des matières premières au Paléolithique*, vol. 1 & 2. Université de Liège (*E.R.A.U.L.*; 75).
- FLENNIKEN J.J.
1987 The Palaeolithic Dyuktai pressure blade technique of Siberia. *Arctic Anthropology*, 24, 2 : 117-132.
- FLOSS H.
1994 *Rohmaterialversorgung im Paläolithikum des Mittelrheingebietes*. Bonn : Dr Rudolf Habelt GMBH. (*Monographien*; 21).
- GALLAY A.
1986 *L'Archéologie demain*. Paris : Belfond.
- GAUSSEN M., GAUSSEN J.
1965 Un atelier de burins à Lagreich. Néo I, Oued Tilemsi (République du Mali). *L'Anthropologie*, 69 : 237-248.
- GENESTE J.-M.
1985 *Analyse lithique d'industries moustériennes du Périgord : une approche technologique du comportement des groupes humains au Paléolithique moyen*. Thèse de doctorat. Bordeaux : Université de Bordeaux I.
- GENESTE J.-M.
1991 L'approvisionnement en matières premières dans les systèmes de production lithique : la dimension spatiale de la technologie. In : *Technología y cadenas operativas líticas*. Reunión internacional, 15-18 enero de 1991 : 1-36. (*Treballs d'arqueologia*; 1).
- GIBSON K.R., INGOLD T. (eds)
1993 *Tools, language and cognition*. Cambridge : Cambridge University Press.
- GOBERT E.G.
1950 Sur un rite capsien du rouge. *Bull. de la Société des Sciences naturelles de Tunisie*, III : 18-23.
- GOBERT E.G.
1954 Capsien et Ibéromaurusien. *Lybica*, II : 441-452.
- GOBERT E.G.
1955 Notions générales acquises sur la Préhistoire de la Tunisie. In : *II^e Congrès Panafricain de Préhistoire, Alger, 1952* : 221-239. Paris : Arts et Métiers Graphiques.

- GRIFFITHS D.R., BERGMAN C.A., CLAYTON C.J., OHNUMA K., ROBINS G.V., SEELEY N.J.
1987 Experimental investigation of the heat treatment of flint. In : *The human uses of flint and chert*. Sieveking G.de G., Newcomer M.H. (eds). Proceedings of the Fourth International Flint Symposium held at Brighton Polytechnic 10-15 April 1983 : 43-52. Cambridge : Cambridge University Press.
- HAMAL-NANDRIN J., SERVAIS J.
1921 Contribution à l'étude de la taille des silex aux différentes époques de l'âge de la pierre. Le nucléus et ses différentes transformations. *Revue anthropologique*, 31.
- HANSEN P.V., MADSEN B.
1983 Flint axe manufacture in the Neolithic. An experimental investigation of a flint axe manufacture site at Hastrup Voengget, East Zealand. *Journal of Danish Archaeology*, 2 : 43-59.
- HAUDRICOURT G.
1964 La technologie, science humaine. *La Pensée*, 115 : 28-35.
- INIZAN M.-L.
1988 *Préhistoire à Qatar*. Paris : E.R.C.
- INIZAN M.-L.
1991 Le débitage par pression : des choix culturels. In : *25 ans d'études technologiques en préhistoire. Bilan et perspectives*. XI^e Rencontres Internationales d'Archéologie et d'Histoire d'Antibes. Actes des rencontres, 18-19-20 octobre 1990 : 367-377. Juan-les-Pins : A.P.D.C.A.
- INIZAN M.-L., LECHEVALLIER M.
1985 La taille du silex par pression à Mehrgarh, Pakistan. La tombe d'un tailleur? *Paléorient*, 11, 1 : 111-117.
- INIZAN M.-L., TIXIER J.
1983 Tell el'Oueili, le matériel lithique. In : *Larsa et Oueili, travaux de 1978-1981* : 164-175. Paris : E.R.C.
- INIZAN M.-L., LECHEVALLIER M., PLUMET P.
1992 A technological marker of the penetration into North America : pressure microblade debitage. Its origin in the Paleolithic of North Asia and its diffusion. In : *Materials Issues in Art and Archaeology, III*. Vandiver, Druzik, Wheeler, Freestone (eds) : 661-681. (*Materials Research Society Symposium Proceedings*; 267).
- INIZAN M.-L., ROCHE H., TIXIER J.
1975-76 Avantage d'un traitement thermique pour la taille des roches siliceuses. *Quaternaria*. Roma, XIX : 1-18.
- INIZAN M.-L., ROCHE H., TIXIER J.
1992 *Technology of Knapped Stone*. Meudon : C.R.E.P. (*Préhistoire de la pierre taillée*; 3).
- INIZAN M.-L., REDURON M., ROCHE H., TIXIER J.
1995 *Technologie de la pierre taillée*. Meudon : C.R.E.P. (*Préhistoire de la pierre taillée*; 4).
- JOUBERT G., VAUFREY R.
1941-46 Le Néolithique du Ténére. *L'Anthropologie*, L : 325-330.
- JOULIAN F.
1994 Peut-on parler d'un système technique chimpanzé? Primatologie et archéologie comparées. In : *De la préhistoire aux missiles balistiques*. Latour B., Lemonnier P. (eds) : 45-64. Paris : La Découverte.
- JULIEN M.
1992 Du fossile directeur à la chaîne opératoire. Evolution de l'interprétation des ensembles lithiques et osseux en France. In : *La Préhistoire dans le monde* : 163-193. Paris : P.U.F. (*Nouvelle Clio*).
- KARLIN C., JULIEN M.
1994 Prehistoric technology : a cognitive science? In : *The ancient mind. Element of cognitive archaeology*. Renfrew C., Zubrow E.B.W. (eds) : 152-164. Cambridge : Cambridge University Press.
- KARLIN C., PLOUX S.
1994 Le travail de la pierre au Paléolithique. Ou comment retrouver l'acteur technique et social grâce aux vestiges lithiques. In : *De la préhistoire aux missiles balistiques*. Latour B., Lemonnier P. (ed.) : 65-82. Paris : La Découverte.
- KEELEY L.H.
1980 *Experimental determination of stone tool uses*. Chicago and London : The University of Chicago Press.
- KELTERBORN P.
1987 *Scientific replication of the standard type Gerzean flint knife*. Poster designed for the Fifth International Flint Symposium in Bordeaux.

- LAPLACE G.
1964 *Essai de typologie systématique*. Ferrare (Annali dell' Università di Ferrare, Sezione 15, supp. 2 au vol. I).
- LAURENT P.
1970 Les sections et les coupes dans le dessin d'archéologie préhistorique. *Origini*, IV : 7-44.
- LEROI-GOURHAN A.
1943 *Evolution et techniques I : L'homme et la matière*. Paris : Albin Michel (réédité en 1971).
- LEROI-GOURHAN A.
1964 *Le geste et la parole I : Technique et langage*. Paris : Albin Michel.
- LEROI-GOURHAN A.
1982 *Interrogation directe et interrogation indirecte des données de fouille*. Séminaire sur les structures d'habitat. Paris : Collège de France (Chaire d'Ethnologie Préhistorique) et L.A.275.
- LEROI-GOURHAN A., BREZILLON M.N.
1972 *Fouilles de Pincevent : Essai d'analyse ethnographique d'un habitat magdalénien (la section 36)*. Paris : C.N.R.S. (*Gallia Préhistoire*, VIII^e supplément).
- LEROY-PROST C., DAUVOIS M., LEROY J.-P.
1981 Projet pour une F.T.A. du groupe des trièdres de l'Acheuléen Nord-Africain. In : *Mélanges à L. Balout. Préhistoire Africaine* : 293-299. Paris : A.D.P.F.
- LITHIC USE-WEAR ANALYSIS
1979 B. Hayden (ed.) New York, San Francisco, London : Academic Press.
- MAC KAY J.H.
1943 *Chanhu-Daro excavations 1935-36*. Boston : Boston Museum of Fine Arts (*American Oriental Society*; 20).
- MADSEN B.
1983 New evidence of late paleolithic settlement in East Jutland. *Journal of Danish Archaeology*, 2 : 12-31.
- MADSEN B.
1984 Flint axe manufacture in the Neolithic : experiments with grinding and polishing of thin-butted flint axes. *Journal of Danish Archaeology*, 3 : 47-62.
- MANOLAKAKIS L.
1994 *La production des outils en silex dans les sociétés hiérarchisées de l'Énéolithique en Bulgarie : évolution, traditions culturelles et organisation sociale*. Thèse de doctorat. Paris : Université de Paris I (Panthéon-Sorbonne).
- MARKS A.E.
1968 The Mousterian industries of Nubia. In : *The Prehistory of Nubia*, Wendorf (ed.) Vol. I : 315-323.
- MAUSS M.
1947 *Manuel d'ethnographie*. Paris : Payot.
- MEIGNEN L.
1995 Levallois lithic production systems in the Middle Palaeolithic of the Near East : the case of the unidirectional method. In : *The definition and interpretation of Levallois technology*. Dibble H.L., Bar Yosef O. (eds) : 361-379. Madison, Wisconsin : Prehistory Press (*Monographs in World Archaeology*; 23).
- MIDANT-REYNES B., TIXIER J.
1981 Les gestes de l'artisan égyptien. *La Recherche*, 12, 120 : 380-381.
- NEWCOMER M.H.
1976 Spontaneous retouch. In : *Second International Symposium on Flint* : 62-64. Maastricht : Nederlandse Geologische Vereniging (*Staringia*; 3).
- OLIVE M.
1988 *Une habitation magdalénienne d'Étiolles ; l'unité P15*. Paris : S.P.F. (*Mémoires de la Société Préhistorique Française*; 20).
- OWEN W.E.
1938 The Kombewa Culture, Kenya Colony. *Man*, 38, 218 : 203-205.
- PELEGRIN J.
1988 Débitage expérimental par pression "Du plus petit au plus grand". In : *Technologie préhistorique* : 37-52. Paris : C.N.R.S. (*Notes et Monographies Techniques*; 25).
- PELEGRIN J.
1991a Sur une recherche technique expérimentale des techniques de débitage laminaire et quelques résultats. In : *Archéologie expérimentale. Tome 2. La terre. L'os et la pierre, la maison et les champs*. Actes du Colloque International "Expérimentation en archéologie : bilan et perspectives" (Archéodrome de Beaune, 6-9 avril 1988) : 118-128. Paris : Editions Errance (*Archéologie aujourd'hui*).

- PELEGRIN J.
1991b Les savoir-faire : une très longue histoire. *Terrain*, 16 : 106-113.
- PELEGRIN J.
1995 *Technologie lithique : le Châtelperro-nien de Roc de Combe, Lot, et de La Côte, Dordogne*. Paris : C.N.R.S. (*Cahiers du Quaternaire*; 20).
- PELEGRIN J., RICHARD A. (eds)
1995 *Les mines de silex au Néolithique en Europe : avancées récentes*. Actes de la table ronde internationale de Vesoul : Les minières de silex néolithiques en Europe occidentale, 18-19 octobre 1991. Paris : C.T.H.S.
- PERLES C.
1987 *Les industries lithiques taillées de Franchthi (Argolide, Grèce)*. Tome I, présentation générale et industries paléolithiques. Bloomington : Indiana University Press (*Excavations at Franchthi Cave, Greece*; 3).
- PETREQUIN P., PETREQUIN A.-M.
1993 *Ecologie d'un outil : la hache de pierre en Irian Jaya (Indonésie)*. Paris : C.N.R.S. (*Monographie du C.R.A.*; 12).
- PHILLIPS J.L.
1991 Refitting, edge-wear and chaînes opératoires. In : *25 d'études technologiques en préhistoire. Bilan et perspectives*. XI^e Rencontres Internationales d'Archéologie et d'Histoire d'Antibes. Actes des rencontres 18-19-20 octobre 1990 : 305-318. Juan-les-Pins : A.P.D.C.A.
- PIGEOT N.
1987 *Magdaléniens d'Etiolles : économie de débitage et organisation sociale*. Paris : C.N.R.S.
- PLOUX S.
1989 *Approche archéologique de la variabilité des comportements techniques individuels. L'exemple de quelques tailleurs magdaléniens à Pincevent*. Thèse de doctorat. Nanterre : Université de Paris X.
- POSSEHL G.
1981 Khambhat beadmaking. *Expedition* 23, 4 : 39-47.
- PRODHOMME J.
1987 *La préparation des publications archéologiques : réflexion, méthode et conseils pratiques*. Paris : M.S.H. (*D.A.F.*; 8.)
- RAO S.R.
1973 *Lothal and the Indus civilisation*. Bombay : Asia Publishing House.
- RENFREW C., ZUBROW E.B.W. (eds).
1994 *The ancient mind. Elements of cognitive archaeology*. Cambridge : Cambridge University Press.
- ROCHE H.
1980 *Premiers outils taillés d'Afrique*. Paris : Société d'ethnographie.
- ROCHE H., TEXIER P.-J.
1991 La notion de complexité dans un ensemble lithique. Application aux séries acheuléennes d'Isenya (Kenya). In : *25 ans d'études technologiques en préhistoire. Bilan et perspectives*. XI^e Rencontres Internationales d'Archéologie et d'Histoire d'Antibes. Actes des rencontres, 18-19-20 octobre 1990 : 99-108. Juan-les-Pins : A.P.D.C.A.
- ROCHE H., TEXIER P.-J.
1996 Evaluation of technical competence of Homo erectus in East Africa during Middle Pleistocene. In : *Evolution and Ecology of Homo erectus, I, PalaeoAnthropology*. Proceedings of the Pithecanthropus Centennial 1893-1993 : 153-167. Lieden : Royal Netherlands Academy of Arts and Sciences.
- ROCHE H., TIXIER J.
1982 Les accidents de taille In : *Tailler! Pour quoi faire : préhistoire et technologie lithique II. Recent progress in microwear studies* : 65-76. Tervuren : Musée Royal d'Afrique Centrale (*Studia Praehistorica Belgica*; 2).
- ROUX V.
1991 Peut-on interpréter les activités lithiques préhistoriques en termes de durée d'apprentissage? Apport de l'ethnologie et de la psychologie aux études technologiques. In : *25 ans d'études technologiques en préhistoire. Bilan et perspectives*. XI^e Rencontres Internationales d'Archéologie et d'Histoire d'Antibes. Actes des rencontres 18-19-20 octobre 1990 : 47-56. Juan-les-Pins : A.P.D.C.A.
- ROUX V., PELEGRIN J.
1989 Taille des perles et spécialisation artisanale. Enquête ethnoarchéologique dans le Gujarat. *Techniques et culture*, 14 : 23-49.
- ROUX V., BRIL B., DIETRICH G.
1995 Skills and learning difficulties involved in stone knapping : the case of stone-bead knapping in Khambhat, India. *World Archaeology*, 27, 1 : 63-87.

- SEMENOV S. A.
1964 *Prehistoric technology*. London : Cory and Mc Key.
- SIRET L.
1924 La taille des trapèzes tardenoisien. *Revue Anthropologique*, XXXIV : 18-70.
- SIRET L.
1933 Le coup de burin moustérien. *Bull. de la Société Préhistorique Française*, XXX : 120-177.
- SMITH P.
1963 A fluted point from the Old World. *American Antiquity*, 28, 3 : 397-399.
- SMITH P.
1966a Report on the Lithic Technology Conference at Les Eyzies, France, 1964. *Current Anthropology*, 7 : 592-593.
- SMITH P.
1966b *Le Solutréen en France*. Bordeaux : Delmas.
- SONNEVILLE-BORDES D. de, PERROT J.
1956 Lexique typologique du Paléolithique supérieur. Outillage lithique. V) Outillage à bord abattu. VI) Pièces tronquées. VII) Lames retouchées. VIII) Pièces variées. IX) Outillages lamellaires, pointe azilienne. *Bull. de la Société Préhistorique Française*, 53 : 547-559.
- TEXIER P.-J.
1989 Approche expérimentale qualitative des principales chaînes opératoires d'un nouveau site acheuléen d'Afrique orientale. In : *La vie aux temps préhistoriques*. Préactes du 23^e Congrès Préhistorique de France : 32-33.
- TEXIER P.-J., ROCHE H.
1995a Polyèdre, sphéroïde et bola : des segments plus ou moins longs d'une même chaîne opératoire. *Cahier Noir*, 7 : 31-40. Girona : C.R.E.P.S.
- TEXIER P.-J., ROCHE H.
1995b The impact of predetermination on the development of some acheulean *chaînes opératoires*. In : *Evolución humana en Europa y los yacimientos de la Sierra de Atapuerca*. Actas, vol. 2 : 403-420.
- TIXIER J.
1956 Le hachereau dans l'Acheuléen nord-africain. Notes Typologiques. In : *Congrès Préhistorique de France*, XV^e session, Poitiers, Angoulême : 914-923.
- TIXIER J.
1963 *Typologie de l'Épipaléolithique de Maghreb*. Paris, A.M.G. (*Mémoire du C.R.A.P.E.*, Alger ; 2).
- TIXIER J.
1967 Procédés d'analyse et questions de terminologie dans l'étude des ensembles industriels du Paléolithique récent et de l'Épipaléolithique en Afrique du Nord-Ouest. In : *Background to evolution in Africa*. Bishop W.W., Clark J.D. (eds) : 771-820. Chicago and London : The University of Chicago Press.
- TIXIER J.
1972 Obtention de lames par débitage "sous le pied". *C.R.S.M. du Bull. de la Société Préhistorique Française*, 69, 5 : 134-139.
- TIXIER J.
1974 Glossary for description of stone tools, with special reference to the Epipalaeolithic of the Maghreb. Translated by M.H. Newcomer. *Newsletter of lithic technology* : special publication, 1.
- TIXIER J.
1976a L'industrie lithique capsienne de l'Aïn Dokkara, région de Tébessa, Algérie. *Libyca*, 24 : 21-54.
- TIXIER J. (avec la collab. de MARMIER F. et TRECALLE G.)
1976b *Le campement préhistorique de Bordj Mellala, Ouargla, Algérie*. Paris : C.R.E.P.
- TIXIER J.
1984 Le débitage par pression. In : *Economie du débitage laminaire* : 57-70. Paris, C.R.E.P. (*Préhistoire de la pierre taillée* ; 2).
- TIXIER J., INIZAN M.-L., ROCHE H.
1980 Terminologie et technologie. Paris : C.R.E.P. (*Préhistoire de la pierre taillée* ; 1).
- TURQ A.
1988 Le Moustérien type Quina du roc de Marsal à Campagne (Dordogne) : contexte stratigraphique, analyse lithologique et technologique. *Document d'Archéologie Périgourdine (A.D.R.A.P.)*, 3 : 5-30.
- VAN NOTEN F. (avec la coll. de CAHEN D., KEELEY L.H. et MOYERSON J.)
1978 *Les chasseurs de Meer*. Bruges : De Tempel. (*Dissertationes Archaeologicae Gandenses*).

VOLKOF P.V., GUIRIA E.I.

- 1991 Recherche expérimentale sur une technique de débitage. *In* : 25 ans d'études technologiques en préhistoire. Bilan et perspectives. XI^e Rencontres Internationales d'Archéologie et d'Histoire d'Antibes. Actes des rencontres 18-19-20 octobre 1990 : 379-390. Juan-les-Pins : A.P.D.C.A.

ZUATE Y ZUBER J.

- 1972 *Le Paléolithique de la vallée de la Somme*. Diplôme de l'Ecole Pratique des Hautes Etudes. Paris : Ecole Pratique des Hautes Etudes.

Multilingual vocabulary

ENGLISH - ARABIC

translated by سلطان محيسن

abrasion : تآكل
 abrupt : شديد الإنحدار
 alternate : متبادل على الحافتين
 alternating : متبادل على نفس الحافة
 angle of retouch : ميلان
 "angle de chasse" : زاوية الطروق
 anvil : سندان
 apex (of a pyramidal core) : هرمي
 aris : حافة
 artifact : صنعية
 atypical : غير نموذجي

 back : ظهر
 backed : حافة مظهرية
 base : قاعدة
 bifacial : ذو وجهين
 blade : نصله
 bladelet : نصله
 blank : سناد (خام)
 blunted : مثلم الحد
 break : كسر
 bulb : بصله
 bulb-scars : تكسر البصله
 burin blow technique :
 تقنية صنع الإزميل
 burin facet : سطح الإزميل
 burin spall : شغفيرة الإزميل
 butt : عقب

 canted : مائل
 "chapeau de gendarme" :
 قبعة الدركي
 clactonian : كلاكتوني
 conchoidal : مخروطي الشكل
 cone : مخروط
 conjoining (flakes) : إتصال
 core : نواة
 core-like : على شكل النواة
 cortex : قشرة
 cortex removal : يزيل القشرة
 cortical : قشري
 cortical reserved zone :
 منطقة قشرية محفوظة

cortical zone : منطقة قشرية
 covering : مغطى
 crest : عُرْف
 crested blade : نصله لها عرف
 crossed : متقاطع
 crutch : مسند

 "débitage" :
 عملية تصنيع الأدوات الحجرية
 "débitage" products :
 انتاج الطروق
 "débitage" axis : محور الطروق
 debris : بقايا
 delineation : تحديد الشكل
 "dent (du burin)" :
 الجزء العامل (سن) في الإزميل
 denticulated : مسنن
 dihedral : متقاطع السطحين
 direct : مباشر
 discontinuous : متقطع
 distal : خلفي
 distribution : انتشار، تركز

 edge : حافة
 end-scraper front : جبهة المكشط
 extent : ممتد

 face : وجه
 facet : مضلع
 first flake : الشظية الأولى
 flake : شظية (رقيقة)
 flaked surface : السطح المطروق
 flaking angle : زاوية التشظية
 flat : أملس
 fluted : مزماري الشكل
 fractionize (to) : يقسم الجزء
 fracture : كسر
 fragment : جزء
 fracture front : جبهة الكسر

 gloss : لمعه

 hackle : مشرط، نزع
 hammer (striker) : مطرقة
 heat treatment : معالجة بالحرارة
 hinged : منعكس

impact point : نقطة الصدمة
 indirect : غير مباشر
 industry : صناعة
 invasion : منتشر
 inverse : مقلوب

 Janus : جانوس

 knapping, knapped : تصنيع
 Kombewa : كومبيوا

 Levallois : لوفالواز
 linear : خطي
 lip : شفه
 low angle : حافة منخفضة

 mesial : متوسط
 method : طريقة
 microburin : ازميل صغير جداً
 (ميكروليتي)
 morphological axis :
 محور الشكل
 morphology : الشكل

 negative bulb : سالب البصله
 negative of removal :
 سالب طرقات الشظية
 nose : خرطوم
 notch : فرضة

 orientation : توجيه
 overhang : نتوء

 parallel : متوازي
 partial : جزئي
 patina : كمخة
 percussion : طرق
 plunging : متجاوز
 polished : مصقول
 polishing : صقل
 position : وضعية
 preform : شكل أولي
 preparation : تحضير
 pressure : ضغط

pressure platform :
سطح الضغط
proximal : امامي
punch : ضربة استخراج النصله
punctiform : على شكل النقطة

ram : نتوء
reassembling : إعادة تجميع
rejuvenation : سطح التجديد
removal : تشظية
retouch : تشذيب
resharpening : تجديد
ridge : حافة
ripples : تموجات
roughout : شكل مختزل

scaled : حرشفي
(على شكل حراشف السمك)

semi-abrupt : شبه حاد
snap : كسرة
shaping : تكييف
shaping out : إعداد الشكل
sharpening : شحذ
sharpening spall :
طرقات تجديد الإزميل
shoulder : كتف (فرضة)
Siret (accidental break) :
كسر عفوي "سيره"
spontaneous removals :
تشذيب تلقائي
stepped : متدرج
striking platform : سطح الطرق
sub-parallel : شبه متوازي

tang (long narrow) :
ساق طويل ورفيع

technique : تقنية
thermal treatment :
معالجة حرارية
tongue : لسين
tranchet blow technique :
طريقة الضربة القاطعة
trihedral point (negative of
microburin scars) :
سالب طرقات تصنيع الإزميل الصغير جداً
trimmed edge : حافة مشذبة
truncation : كسر (قطع) منظم

unretouched : خام غير مشذب

versant : سفح

winged : مجنح

flake : رقيقة (شظية)

burin blow technique

ARABIC - ENGLISH

bulb-scars : تكسر البصله

conjoining (flakes) : إتصال

angle : زاوية

shaping : تكييف

أداة : tool

"angle de chasse" : زاوية الطرق

spontaneous removals : تلقائي

إزميل صغير جداً (ميكروليتي) :

flanking angle : زاوية التشظية

orientation : توجيه

microburin

bifacial : ذو وجهين

Janus : جانوس

reassembling : إعادة تجميع

tang : ساق

fragment : جزء

shaping out : إعداد الشكل

sاق طويل ورفيع :

partial : جزئي

proximal : امامي

tang (long narrow)

fracture front : جبهة الكسر

ألمس : flat

negative bulb : سالب البصله

end-scraper front : جبهة المكشط

"débitage" products : إنتاج الطرق

سالب طرقات الشظية :

canted : حافر الفرس

distribution : إنتشار

negative of removal

ridge, arris : حافة

بصله : bulb

rejuvenation : سطح التجديد

trimmed edge : حافة مشذبة

بقايا : debris

burin facet : سطح الإزميل

backed : حافة مظهره

تآكل : abrasion

pressure platform : سطح الضغط

low angle : حافة منخفضة

تجديد : resharpening

striking platform : سطح الطرق

حرشفي (على شكل حراشف السمك) :

تحديد الشكل : delineation

versant : سفح

scaled

تحضير : preparation

سليبي طرقات تصنيع الإزميل

unretouched : خام غير مشذب

تشذيب : retouch

الصغير جداً :

nose : خرطوم

تشظية : removal

trihedral point

خطي : linear

تصنيع : knapping, knapped

(negative of microburin scars)

خلفي : distal

تقنية : technique

blank : خام

تقنية صنع الإزميل :

سندان : anvil

"débitage" axis : محور الطرق	notch : فريضة	semi-abrupt : شبه حاد
cone : مخروط	base : قاعدة	sub-parallel : شبه متوازي
conchoidal : مخروطي الشكل	base : قاعدة	abrupt : شديد الإنحدار
fluted : مزماري الشكل	قبعة الدركي :	sharpening : شحذ
crutch : مسند	"chapeau de gendarme"	morphology : الشكل
denticulated : مسنّن	cortex : قشرة	preform : شكل أولي
hackle : مشرط، نزع	cortical : قشري	roughout : شكل مختزل
polished : مصقول	shoulder : كتف (فريضة)	first flake : الشظية الأولى
facet : مضلع	fracture : كسر	flaked surface : شظية (رقيقة)
hammer (striker) : مطرقة	snap : كسرة	lip : شفة
heat treatment : معالجة بالحرارة	كسر عفوي :	burin spall : شفييرة إزميل
covering : مغطى	Siret (accidental break)	polishing : صقل
punch : مقص	truncation : كسر منقطع	industry : صناعة
inverse : مقلوب	clactonian : كلاكتوني	artifact : صنعية
extent : ممتد	patina : كمخة	
invasive : منتشر	Kombewa : كومبيوا	punch : ضربة استخراج النصلة
cortical zone : منطقة قشرية	tongue : لسين	pressure : ضغط
: منطقة قشرية محفوظة	gloss : لمعه	ridge, arris : ضلع
cortical reserved zone	Levallois : لوفالوان	percussion : طرق
hinged : منعكس	direct : مباشر	طرقات تجديد الإزميل :
discontinuous : منقطع	alternate : متبادل على الحافتين	sharpening spall
	متبادل على نفس الحافة :	method : طريقة
overhang, ram : نتوء	alternating	طريقة الضربة القاطعة :
hackle : مشرط، نزع	plugging : متجاوز	tranchet blow technique
blade : نصلة	stepped : متدرج	back : ظهر
crested blade : نصله لها عرّف	crossed : متقاطع	crest : عرّف
bladelet : نصيله	متقاطع السطحين : dihedral	عقب : butt
impact point : نقطة الصدمة	متقطع : discontinuous	على شكل النقطة : punctiform
core : نواة	متوازي : parallel	على شكل النواة : core-like
apex (of a : هرمي	متواصل : continuous	عملية تصنيع الأدوات الحجرية :
pyramidal core)	متوسط : mesial	"débitage"
face : وجه	مثلّم الحد : blunted	
position : وضعية	مجنح : winged	غير مباشر : indirect
cortex removal : يزيل القشرة	محور الشكل : morphological axis	غير نمذجي : atypical
fractionize (to) : يقسم		

ENGLISH : FRENCH

abrasion : **abrasion**
abrupt : **abrupt(e)**
addition : **ajout**
alternate : **alterne**
alternating : **alternant(e)**
angle (of retouch) : **inclinaison**
angle de chasse : **angle de chasse**
anvil : **enclume**
apex (of a pyramidal core) : **pyramidion**
arris : **nervure**
atypical : **atypique**

back : **dos**
backed : **abattu**
base : **base**
bifacial : **bifacial(e)**
blade : **lame**
bladelet : **lamelle**
blank : **support**
blunting : **émoussé**
break : **cassure**
bulb : **bulbe**
bulb scars : **esquillement du bulbe**
burin blow technique : **burin (technique du coup de)**
burin facet : **pan (du burin)**
burin spall : **chute de burin**
burin tip : **dent du burin**
butt : **talon**

canted : **déversé**
caréné (carénage) : **caréné (carénage)**
channel-flaked : **fluté**
chapeau de gendarme : **chapeau de gendarme**
cintrage : **cintrage**
clactonian : **clactonien**
conchoid : **conchoïde**
cone : **cône**
conjoining (flakes) : **raccord**
continuous : **continu(e)**
core : **nucléus**
core-like : **nucléiforme**
cortex : **cortex**
cortex removal : **décorticage**
cortical : **cortical(e)**
cortical reserved zone : **réserve corticale**
covering : **couvrant(e)**
crest : **crête**
crested blade : **lame à crête**

crossed : **croisé(e)**
crutch : **béquille**

debitage : **débitage**
debitage axis : **axe de débitage**
debitage products : **produits de débitage**
debris : **débris**
delineation : **délinéation**
denticulated : **denticulé(e)**
diacritical diagram : **schéma diacritique**
dihedral : **dièdre**
direct : **direct(e)**
direction line : **hachure**
discontinuous : **discontinu(e)**
distal : **distal(e)**
distribution : **répartition**

edge : **bord**
end-scraper front : **front de grattoir**
extent : **étendue**

face : **face**
facetted : **facetté**
first flake : **entame**
flake : **éclat**
flaked surface : **surface débitée**
flaking angle : **angle d'éclatement**
flat, plain : **lisse**
fluted : **cannelé**
fracture : **fracture**
fracture front : **front de fracture**
fragment : **fragment**

gloss : **lustre**

hackle : **lancette**
hammer : **percuteur**
heat treatment : **traitement thermique**
hinged : **réfléchi(e), rebroussé(e)**

impact point : **point d'impact**
indirect : **indirect(e)**
industry : **industrie**
invasive : **envahissant(e)**
inverse : **inverse**

Janus flake : **éclat Janus** (see Kombewa) :

knapping accident : **accident de taille**
knapping, knapped : **taille, taillé(e)**
Kombewa (method, flake) : **Kombewa (méthode, éclat)**

languette (accidental break) : **languette (fracture en)**
Levallois (method, flake, etc.) : **Levallois (méthode, éclat, etc.)**
linear : **linéaire**
lip : **lèvre**
localization : **localisation**
low angle : **rasant(e)**

mesial : **mésial(e)**
method : **méthode**
microburin : **microburin**
morphological axis : **axe morphologique**
morphology : **morphologie**

nacelle (accidental break) : **nacelle (fracture en)**
negative bulb : **contre-bulbe**
negative of removal, scar : **négatif d'enlèvement**
nose : **museau**
notch : **coche**

orientation : **orientation**
overhang : **corniche**

parallel : **parallèle**
partial : **partiel(le)**
patina : **patine**
pecking : **bouchardage**
percussion : **percussion**
piquant-trièdre : **piquant-trièdre**
plunging : **outrepassé(e)**
polish : **poli(e)**
polishing : **polissage**
position : **position**
preform : **préforme**
preliminary flaking : **épannelage**
preparation : **préparation**
pressure : **pression**
pressure platform : **plan de pression**
proximal : **proximal(e)**
punch : **punch**
punctiform : **punctiforme**

refit(ting) : **remontage**
rejuvenation core tablet
(flake) : **tablette (éclat) de ravivage**
removal : **enlèvement**
removal morphology : **morphologie d'un enlèvement**
resharpening : **ravivage, avivage**
retouch : **retouche**
ridge : **arête**
ripples : **ondulations**
roughout : **ébauche**
rubbed down : **égrisé**

scaled : **écailleux(se)**
section : **section**
semi-abrupt : **semi-abrupt(e)**
shaping : **façonnage**
shaping out : **mise en forme**
sharpening : **affûtage**
sharpening spall : **recoupe de burin**
shoulder : **cran, épaulement**
Siret (accidental break) : **Siret (accident)**
sketch : **croquis**
spontaneous removal : **spontané (enlèvement)**
spur : **éperon**
stepped : **scalariforme**
striking platform : **plan de frappe**
sub-parallel : **sub-parallèle**

tang : **pédoncule, soie**
technique : **technique**
tongue : **languette**
tool : **outil**
tranchet blow technique : **tranchet (coup du)**
trimmed edge : **bord taillé**
truncation : **troncature**

unmodified : **brut**
unretouched : **brut de débitage, brut de taille**

versant : **versant**
winged : **aile d'oiseau (en)**

FRENCH : ENGLISH

abattu : **backed**
abrasion : **abrasion**
abrupt(e) : **abrupt**

accident de taille : **knapping accident**
affûtage : **sharpening**
aile d'oiseau (en) : **winged**
ajout : **addition**
alternant(e) : **alternating**
alterne : **alternate**
angle d'éclatement : **flaking angle**
angle de chasse : **angle de chasse**
arête : **ridge**
atypique : **atypical**
axe de débitage : **debitage axis**
axe morphologique : **morphological axis**

base : **base**
béquille : **crutch**
bifacial(e) : **bifacial**
bord : **edge**
bord taillé : **trimmed edge**
bouchardage : **pecking**
brut : **unmodified**
brut de débitage, brut de taille : **unretouched**
bulbe : **bulb**
burin (technique du coup de) : **burin blow technique**

cannelé : **fluted**
caréné (carénage) : **caréné (carénage)**
cassure : **break**
chapeau de gendarme : **chapeau de gendarme**
chute de burin : **burin spall**
cintrage : **cintrage**
clactonien : **clactonian**
coche : **notch**
conchoïde : **conchoid**
cône : **cone**
continu(e) : **continuous**
contre-bulbe : **negative bulb**
corniche : **overhang**
cortex : **cortex**
cortical(e) : **cortical**
couvrant(e) : **covering**
cran, épaulement : **shoulder**
crête : **crest**
croisé(e) : **crossed**
croquis : **sketch**

débitage : **debitage**
débris : **debris**
décorticage : **cortex removal**
délinéation : **delineation**

dent du burin : **burin tip**
denticulé(e) : **denticulated**
déversé : **canted**
dièdre : **dihedral**
direct(e) : **direct**
discontinu(e) : **discontinuous**
distal(e) : **distal**
dos : **back**

ébauche : **roughout**
écailleux(se) : **scaled**
éclat : **flake**
égrisage : **rub**
émoussé : **blunted**
enclume : **anvil**
enlèvement : **removal**
entame : **first flake**
envahissant(e) : **invasive**
épannelage : **preliminary flaking**
épaulement : **shoulder**
éperon : **spur**
esquillement du bulbe : **bulb scars**
étendue : **extent**

face : **face**
facetté : **facetted**
façonnage : **shaping**
flûté : **channel-flaked**
fracture : **fracture**
fragment : **fragment**
front de fracture : **fracture front**
front de grattoir : **end-scraper front**

hachure : **direction line**

inclinaison : **angle (of retouch)**
indirect(e) : **indirect**
industrie : **industry**
inverse : **inverse**

Janus (éclat) : **Janus (flake)**
see **Kombewa**

Kombewa (méthode, éclat) : **Kombewa (method, flake)**

lame : **blade**
lame à crête : **crested blade**
lamelle : **bladelet**
lancette : **hackle**
languette (fracture en) : **languette (accidental break)**
languette : **tongue**

Levallois (méthode, éclat, etc.) : **Levallois (method, flake etc.)**

lèvre : **lip**

linéaire : **linear**

lisse : **flat, plain**

localisation : **localization**

lustre : **gloss**

mésial(e) : **mesial**

méthode : **method**

microburin : **microburin**

mise en forme : **shaping out**

morphologie : **morphology**

morphologie d'un

enlèvement : **removal**

morphology

museau : **nose**

nacelle (fracture en) :

nacelle (accidental break)

négatif d'enlèvement :

negative of removal, scar

nervure : **arris**

nucléiforme : **core-like**

nucléus : **core**

ondulations : **ripples**

orientation : **orientation**

outil : **tool**

outrépassé(e) : **plunging**

pan (du burin) : **burin facet**

parallèle : **parallel**

partiel(le) : **partial**

patine : **patina**

pédoncule : **tang**

percussion : **percussion**

percuteur : **hammer**

piquant-trièdre :

piquant-trièdre

plage corticale (voir
cortical) : **cortical zone**

plan de frappe : **striking
platform**

plan de pression : **pressure
platform**

point d'impact : **impact point**

poli(e) : **polished**

polissage : **polishing**

position : **position**

préforme : **preform**

préparation : **preparation**

pression : **pressure**

produits de débitage :

debitage products

proximal(e) : **proximal**

punch : **punch**

punctiforme : **punctiform**

pyramidion : **apex (of a
pyramidal core)**

raccord : **conjoining (flakes)**

rasant(e) : **low angle**

ravivage : **resharpening**

recoupe de burin :

sharpening spall

réfléchi, rebroussé(e) : **hinged**

remontage : **refitting**

répartition : **distribution**

réserve corticale : **cortical
reserved zone**

retouche : **retouch**

scalariforme : **stepped**

schéma diacritique :
diacritical diagram

section : **section**

semi-abrupt(e) : **semi-abrupt**

Siret (accident de) : **Siret
(accidental break)**

soie : **tang (long, narrow)**

spontané (enlèvement) :
spontaneous removal

sub-parallèle : **sub-parallel**

support : **blank**

surface débitée : **flaked
surface**

tablette (éclat) de ravivage :
**core tablet, rejuvenation
core flake**

taille, taillé(e) : **knapping,
knapped**

talon : **butt**

technique : **technique**

traitement thermique : **heat
treatment**

tranchet (coup du) : **tranchet
blow technique**

troncature : **truncation**

versant : **versant**

ENGLISH : GERMAN

translated by J. Hahn

abrasion : **Verrundung**
 abrupt : **Steil**
 addition : **Residue**
 alternate : **alternierend**
Zweikantig
 alternating : **alternierend**
Einkantig
 angle (of retouch) :
Retuschewinkel
angle de chasse :
Schlagwinkel
 anvil : **Amboss**
 apex (of a pyramidal core) :
Fuss (eines
pyramidenförmigen Kerns)
 arris : **Grat**
 atypical : **atypisch**

back : **Rücken**
 backed : **rückengestumpfte**
(Kante)
 base : **Basis**
 bifacial : **bifazial**
 blade : **Klinge**
 bladelet : **Mikroklinge**
 blank : **Grundform**
 blunting : **verrundet**
 break : **Bruch**
 bulb : **Bulbus**
 bulb scars : **Schlagnarbe**
 burin blow technique :
Stichschlag-Technik
 burin facet : **Stichelfacette**
 burin spall : **Stichelabfall**
 burin tip : **Stichelschneide**
 butt : **Schlagflächenrest**

canted : **stumpfwinklig(er)**
Schlaflächenrest
caréné : **Kiel, (kielförmig)**
chapeau de gendarme :
chapeau de gendarme
cintrage : **gewölbte**
Abbaufäche
 clactonian : **clactonian**
 conchoid : **Bulbus**
 cone : **Kegel**
 conjoining (flakes) :
Zusammenpassung
 continuous : **durchgehend**
 core : **Kern(stein)**
 core tablet, rejuvenation core
 flake : **Kernscheibe**
 core-like : **kernartig**
 cortex : **Kortex (Rinde)**

cortex removal : **Endrindung**
 cortical : **Kortex-**
 cortical reserved zone :
Kortexbereich
 cortical zone : **Kortex fläche**
 covering : **flächendeckend**
 crest : **Kernkante**
 crested blade :
Kernkantenklinge
 crossed : **überkreuzt**
 crutch : **Druckstab**

debitage : **Abschlagmaterial**
(Grundproduktion)
 debitage axis : **Schlagachse**
 debitage products :
Grundform
 debris : **Trümmer**
 delineation : **Kantenform**
 denticulated : **gezähnt**
 diacritical diagram :
unterscheidendes
(diakritisches) Schema
 dihedral : **Mehrschlag**
(stichel)
 direct : **direkt**
 direction line : **Schraffierung**
 discontinuous : **unterbrochen**
 distal : **distal**
 distribution : **Verteilung**

edge : **Kante**
 end-scraper front :
Kratzerstirn
 extent : **Ausdehnung**

face : **Fläche**
 faceted : **Facettiert**
 first flake : **erste Abhebung**
 flake : **Abschlag**
 flaking angle : **Abbauwinkel**
 flat, plain : **glatt**
 fluted : **kanneliert**
 fracture : **Bruch**
 fracture front : **Bruch Kante**
 fragment : **Fragment**

gloss : **Glanz**

hackle : **Lanzettsprung**
 hammer : **Schlagstein**
 heat treatment : **Tempern**
 hinged : **angelförmig**

impact point : **Treffpunkt**
 indirect : **indirekt**
 industry : **Industrie**
 invasive : **flächendeckend**

inverse : **invers**

Janus flake : **Janusabschlag**

knapping accident : **Bruch**
 knapping, knapped :
Steinbearbeitung,
geschlagen
 Kombewa (method) :
Kombewa (Methode)

Levallois (method) :
Levallois (Methode)
 linear : **linear**
 lip : **Lippe**
 localization : **Lokalisierung**
 low angle : **spitzwinklig**

mesial : **medial**
 method : **Methode**
 microburin : **Kerbrest**
 morphological axis :
Symmetrieachse
 morphology : **Morphologie**

nacelle : **kahnförmiger**
Aussprung
 negative bulb :
Bulbusnegativ
 negative of removal, scar :
Abschlagnegativ
 nose : **Nase**
 notch : **Kerbe**

orientation : **Orientierung**
 overhang : **Überhang**

parallel : **parallel**
 partial : **partiell**
 patina : **Patina**
 pecking : **Verstumpfung,**
verstumpft
 percussion : **Schlag**
piquant-trièdre : **Kerbrest**
negativ
 plunging : **durchgeschlagen**
 polished : **geschliffen**
 polishing : **Schliff**
 position : **Lage**
 preform : **Vorarbeit**
 preliminary flaking :
Zurichtung
 preparation : **Präparation**
 pressure : **Druck**
 pressure platform :
Druckfläche
 proximal : **proximal**
 punch : **Zwischenstück**

punctiform : **punktförmig**
refitting : **Zusammensetzen**
removal : **Abhebung**
removal morphology :
Abschlagmorphologie
resharpening :
Nachschärfung
retouch : **Retusche**
ridge : **Grat**
ripples : **Wallnerlinien**
roughout : **Versuch**
rubbed down : **Reibspuren,**
gerieben

scaled : **schuppig**
section : **Querschnitt**
semi-abrupt : **fein**
shaping : **Bearbeitung**
shaping out : **Zurichtung**
sharpening : **Nachschärfung**
sharpening spall :
sekundärer Stichelabfall
shoulder : **Schulter**
Siret (accidental break) :
Siret (-Bruch)
sketch : **Skizze**
snap : **Bruch**
spontaneous removal :
spontan
spur : **Vorsprung**
stepped : **stufig**
striking platform :
Schlagfläche
sub-parallel : **annähernd**
paralle

tang : **Stiel**
technique : **Technik**
tongue : **zungenförmig**
tool : **Werkzeug**
tranchet blow technique :
Schneidenschlag
trimmed edge : **geschlagen**
Kante
truncation : **Endretusche**

unmodify : **Grundform**
unretouched : **Grundform**

versant :
Präparationsflächen

winged : **geflügelt**
(Schlagflächenrest)

GERMAN : ENGLISH

Abbauwinkel : **flaking angle**
Abhebung : **removal**

Abschlag : **flake**
Abschlagmaterial
(Grundproduktion) : **debitage**
Abschlagmorphologie :
removal morphology
Abschlagnegativ : **negative**
of removal, scar
alternierend Einkantig :
alternating
alternierend Zweikantig :
alternate
Amboss : **anvil**
angelförmig : **hinged**
annähernd paralle :
sub-parallel
atypisch : **atypical**
Ausdehnung : **extent**

Basis : **base**
Bearbeitung : **shaping**
bifazial : **bifacial**
Bruch : **break**
Bruch : **fracture**
Bruch : **knapping accident**
Bruch : **snap**
Bruch Kante : **fracture front**
Bulbus : **bulb**
Bulbus : **conchoid**
Bulbusnegativ : **negative**
bulb

chapeau de gendarme :
chapeau de gendarme
clactonian : **clactonian**

direkt : **direct**
distal : **distal**
Druck : **pressure**
Druckfläche : **pressure**
platform
Druckstab : **crutch**
durchgehend : **continuous**
durchgeschlagen : **plunging**

Endretusche : **truncation**
Endrindung : **cortex removal**
erste Abhebung : **first flake**

Facettiert : **faceted**
fein : **semi-abrupt**
Fläche : **face**
flachendeckend : **covering**
flächendeckend : **invasive**
Fragment : **fragment**
Fuss (eines
pyramidenförmigen Kerns) :
apex (of a pyramidal core)

geflügelt
(Schlagflächenrest) : **winged**
geschlagen Kante : **trimmed**
edge
geschliffen : **polished**
gewölbte Abbaufäche :
cintrage
gezähnt : **denticulated**
Glanz : **gloss**
glatt : **flat, plain**
Grat : **arris**
Grat : **ridge**
Grundform : **blank**
Grundform : **debitage**
products
Grundform : **unmodify**
Grundform : **unretouched**

indirekt : **indirect**
Industrie : **industry**
invers : **inverse**

Janusabschlag : **Janus flake**

kahnförmiger Aussprung :
nacelle
kanneliert : **fluted**
Kante : **edge**
Kantenform : **delineation**
Kegel : **cone**
Kerbe : **notch**
Kerbrest : **microburin**
Kerbrest negativ :
piquant-trièdre
Kern(stein) : **core**
kernartig : **core-like**
Kernkante : **crest**
Kernkantenklinge : **crested**
blade
Kernscheibe : **core tablet,**
rejuvenation core flake
Kiel, (kielförmig) : *caréné*
Klinge : **blade**
Kombewa (Methode) :
Kombewa (method)
Kortex (Rinde) : **cortex**
Kortex fläche : **cortical zone**
Kortex- : **cortical**
Kortexbereich : **cortical**
reserved zone
Kratzerstirn : **end-scraper**
front

Lage : **position**
Lanzettsprung : **hackle**
Levallois (Methode) :
Levallois (method)
linear : **linear**

Lippe : **lip**
Lokalisierung : **localization**

medial : **mesial**
Mehrschlag (stichel) :
dihedral
Methode : **method**
Mikroklinge : **bladelet**
Morphologie : **morphology**

Nachschärfung :
resharpening
Nachschärfung : **sharpening**
Nase : **nose**

Orientierung : **orientation**

parallel : **parallel**
partiell : **partial**
Patina : **patina**
Präparation : **preparation**
Präparationsflächen : **versant**
proximal : **proximal**
punktförmig : **punctiform**

Querschnitt : **section**

Reibspuren, gerieben :
rubbed down
Residue : **addition**
Retusche : **retouch**
Retuschewinkel : **angle (of retouch)**
Rücken : **back**
rückengestumpfte (Kante) :
backed

Schlag : **percussion**
Schlagachse : **debitage axis**
Schlagfläche : **striking platform**
Schlagflächenrest : **butt**
Schlagnarbe : **bulb scars**
Schlagstein : **hammer**
Schlagwinkel : **angle de chasse**
Schliff : **polishing**
Schneidenschlag : **tranchet blow technique**
Schraffierung : **direction line**
Schulter : **shoulder**
schuppig : **scaled**
sekundärer Stichelabfall :
sharpening spall
Siret (-Bruch) : **Siret (accidental break)**
Skizze : **sketch**
spitzwinklig : **low angle**
spontan : **spontaneous removal**
Steil : **abrupt**
Steinbearbeitung,
geschlagen : **knapping, knapped**
Stichelabfall : **burin spall**
Stichelfacette : **burin facet**
Stichelschlag-Technik :
burin blow technique
Stichelschneide : **burin tip**
Stiel : **tang**
stufig : **stepped**
stumpfwinklig(er)
Schlaflächenrest : **canted**

Symmetrieachse :
morphological axis

Technik : **technique**
Tempern : **heat treatment**
Trefferpunkt : **impact point**
Trümmer : **debris**

Überhang : **overhang**
überkreuzt : **crossed**
unterbrochen : **discontinuous**
unterscheidendes
(diakritisches) Schema :
diacritical diagram

verrundet : **blunted**
Verrundung : **abrasion**
Verstumpfung, verstumpft :
pecking
Versuch : **roughout**
Verteilung : **distribution**
Vorarbeit : **preform**
Vorsprung : **spur**

Wallnerlinien : **ripples**
Werkzeug : **tool**

zungenförmig : **tongue**
Zurichtung : **preliminary flaking**
Zurichtung : **shaping out**
Zusammenpassung :
conjoining (flakes)
Zusammensetzen : **refitting**
Zwischenstück : **punch**

ENGLISH : GREEK

translated by

A. Moundrea-Agrafioti

abrasion : αποτριβή
abrupt : απότομη
(επεξεργασία)
addition : πρόσθεμα
alternate : εναλλάχ
alternating :
εναλλασσόμενη
(επεξεργασία)
angle (of retouch) : κλίση
(της επεξεργασίας)
angle de chasse : γωνία
απόσπασης
anvil : αμόνι
apex (of a pyramidal core) :
πθραμίδειο
arris : νεθρωση
atypical : αθπικός

back : ράψη
backed : πλευρά με
αποτόμη επεξεργασία
base : βάση
bifacial : αμφιπρόσωπη
επεξεργασία
blade : λεπίδα
bladelet : λεπίδα με
κορθφή
blank : θπόβαθρο
blunting : αμβλθμένος
break : θραση
bulb : βολβός, κώνος
bulb scars : απολέπιση
τοθ κώνοθ
burin blow technique :
τειψνική της κροθσης
της γλθφίδας
burin facet : έδρα
γλθφίδας
burin spall : απόρριμα
γλθφίδας
burin tip : ακμή γλθφίδας
butt : φτέρνα

canted : γερτή (φτέρνα)
caréné, carénage : καρένα,
τροπίδωση
channel-flaked : ραβδωτός
chapeau de gendarme :
καπελόσφημος
cintrage : αυίδωση, τοθ
πθρήνα
clactonian : κλακτόνιος
conchoid : κογψοειδές
cone : κώνος

conjoining (flakes) :
σθναρμογή
continuous : σθνειψής
(επεξεργασία)
core : πθρήνας
core tablet, ρεξθωενατιον
ψορε φλακε U δίσκος
αναnéωσης πθρήνα
core-like : πθρηνοειδής
cortex : φλοιός
cortex removal :
αποφλοιώση
cortical : φλοιώδης
cortical reserved zone :
φλοιώδες μέρος
covering :
επικαλθπτοθσα
(επεξεργασία)
crest : κορθφή
crested blade :
μικρολεπίδα
crossed : διασταθροθμενη
(επεξεργασία), ψιαστί
crutch : σθμπιεστής

debitage : απόκροθση
debitage axis : άχονας
απόκροθσης
debitage products :
προϊόντα απόκροθσης
debris : σθντριμμα
delineation : περίγραμμα
denticulated : οδοντωτός
diacritical diagram :
διακριτικό σήμα
dihedral : διεδρικός
direct : ορθή
(επεξεργασία)
direction line :
γραμμοσκίαση
discontinuous : ασθνειψής
distal : άνω (άκρο)
distribution : κατανομή

edge : πλευρά
end-scraper front : μέτωπο
χέστροθ
extent : έκταση

face : όνη
facetted : πολθεδρικός
first flake : πρωτότομο
flake : φολίδα
flaked surface :
αποκροθσμένες
επιφάνειες
flaking angle : γωνία
απόκροθσης

flat, plain : λεία, επίπεδη
(φτέρνα)
fluted : αθλακωτός
fracture : θραση
fracture front : μέτωπο
θρασης
fragment : τμήμα

gloss : στίλβη
hackle : λογψοειδής
ρωγμή

hackle : ρωγμή
hammer : κροστήρας
heat treatment : θερμική
διεργασία
hinged : αναστροφή

impact point : σημείο
κροθσης
indirect : έμμεσος (η)
industry : εργοτειψνία
invasive : επιδρομική
(επεξεργασία)
inverse : ανάστροφος

Janus (flake) : Ιανός
(φολίδα), see Kombeva

knapping accident :
αθβψημα κατα τη
λάχεθση
knapping, knapped :
λάχεθση, λαχέμένος
Kombewa (method) :
Κομπέοθα (μέθοδος)

Levallois (method) :
Λεβαλλοθά (μέθοδος)
linear : νηματοειδής
(φτέρνα)
lip : ψείλος
localization : εντοπισμός
low angle : επικλινή
(επεξεργασία)

mesial : μεσαίο (τμήμα)
method : μέθοδος
microburin : μικρογλθφίδα
morphological axis :
μορφολογικός άχονας
morphology : μορφολογία
nacelle : λεμβοειδής
θραση

negative bulb : αντικώνος
negative of removal, scar :
αρνητικό απολέπιση
nose : ρθγψος
notch : εγκοπή

orientation :
προσανατολισμός
overhang : γείσο

parallel : παράλληλος
partial : μερική
(επεξεργασία)
patina : πατίνα
pecking : σφθοροκόπημα
percussion : επίκροση
riquant-trièdre : αιχμηρό
τρίεδρο
plunging : θπέρβαση
polish : λειασμένος
polishing : λείανση
position : θέση
(επεξεργασίας)
preform : προσψέδιο
preliminary flaking :
χειφόντρισμα
preparation : προετοιμασία
pressure : πίεση
pressure platform : επίπεδο
πίεση
proximal : κάτω (τμήμα)
punch : πίεστρο
punctiform : στιγμοειδής

refit(ting) : ανασθνδεση
(σθναρμολόγηση)
removal : απολέπιση
removal morphology :
μορφολογία απολέπισης
resharpening : ανανέωση
retouch : επεξεργασία
ridge : ακμή
ripples : κθματώσεις
roughout : προσψεδίασμα
rubbed down : λείανση

scaled : φολιδωτή
(επεξεργασία)
section : τομή
semi-abrupt : ημιαπότομη
επεξεργασία
shaping : κατεργασία
shaping out : διαμόρφωση
sharpening : ακόνισμα,
ανανέωση
sharpening spall :
ανανέωση γλθφίδας
shoulder : εσοφή, ώμος
Siret (αψιδενταλ
breack) U θλάση Σιρέτ,
επιμήκης θλάση
sketch : σκαρίφημα
spontaneous removal :
αθθόρμητη απολέπιση

spur : εμβολοειδής
(φτέρνα)
stepped : βαθμιδωτή
(επεξεργασία)
striking platform : επίπεδο
επίκροσης
sub-parallel :
θποπαράλληλη
(επεξεργασία)

tang : μίσψος
technique : τειψνική
tongue : γλωσσίδα
tool : εργαλείο
tranchet blow technique :
τειψνική τοθ κοπέα
trimmed edge : πλεθρά
λάχεθση
truncation : κολόβωση

unmodify :
ανεπεξέργαστος (πρόν
απόκροσης)
unretouched :
ανεπεξέργαστος (πρόν
λάχεθση)

versant : παρθφή

winged : πτερθγόσσημη
φτέρνα

GREEK : ENGLISH

αιχμηρό τρίεδρο :
riquant-trièdre
ακμή : ridge
ακμή γλθφίδας : burin tip
ακόνισμα, ανανέωση :
sharpening
αμβλυμένος : blunted
αμφιπρόσωπη
επεξεργασία : bifacial
αμόνι : anvil
ανανέωση : resharpening
ανανέωση γλθφίδας :
sharpening spall
αναστροφή : hinged
ανασύνδεση
(συναρμολόγηση) :
refit(ting)
ανάστροφος : inverse
ανεπεξέργαστος (πρόν
απόκρουσης) : unmodify
ανεπεξέργαστος (πρόν
λάξευσης) : unretouched
αντικώνος : negative bulb

αποφλοώση : cortex
removal
αποκρουσμένες
επιφάνειες : flaked surface
απολέπιση : removal
απολέπιση του κώνου :
bulb scars
αποτριβή : abrasion
απόκρουση : debitage
απόρριμα γλθφίδας : burin
spall
απότομη (επεξεργασία) :
abrupt
αρνητικό απολέπισης :
negative of removal, scar
ασυνεχής : discontinuous
ατυπικός : atypical
ατύχημα κατα τη
λάξευση : knapping
accident
αυλακωτός : fluted
αυθόρμητη απολέπιση :
spontaneous removal
άνω (άκρο) : distal
άξονας απόκρουσης :
debitage axis
αψίδωση, του πυρήνα :
cintrage

βαθμιδωτή
(επεξεργασία) √ στεπεεδ
βάση : base
βολβός, κώνος : bulb

χείλος : lip

διακριτικό σχήμα :
diacritical diagram
διαμόρφωση : shaping out
διασταυρούμενη
(επεξεργασία), χιαστί :
crossed
διεδρικός : dihedral
δίσκος ανανέωσης
πυρήνα : core tablet,
rejuvenation core flake

εγκοπή : notch
εμβολοειδής (φτέρνα) : spur
εναλλασσόμενη
(επεξεργασία) : alternating
εναλλάξ : alternate
εντοπισμός : localization
επεξεργασία : retouch
επιδρομική (επεξεργασία) :
invasive
επικάλυπτουσα
(επεξεργασία) : covering

επικλινής (επεξεργασία) :
low angle
επίκρουση : **percussion**
επίπεδο επίκρουσης :
striking platform
επίπεδο πίεση : **pressure platform**
εργαλείο : **tool**
εργοτεχνία : **industry**
εσοχή : **shoulder**
έδρα γλυφίδας : **burin facet**
έκταση : **extent**
έμμεσος (η) : **indirect**

φλοιός : **cortex**
φλοιώδες μέρος : **cortical reserved zone**
φλοιώδης : **cortical**
φλοιώδης ζώνη : **cortical zone**
φολιδωτή (επεξεργασία) : **scaled**
φολίδα : **flake**
φτέρνα : **butt**

γείσο : **overhang**
γερτή (φτέρνα) : **canted**
γλωσσίδα : **tongue**
γραμμοσκίαση : **direction line**
γωνία απόκρουσης : **flaking angle**
γωνία απόσπασης : *angle de chasse*

ημιαπότομη επεξεργασία :
semi-abrupt

Ιανός (φολίδα), σεε
Κομβεωα : **Janus (flake)**

καπελόςχημος : *chapeau de gendarme*
καρένα, τροπίδωση :
caréné, carénage
κατανομή : **distribution**
κατάτμηση : **breakage**
κατεργασία : **shaping**
κάτω (τμήμα) : **proximal**
κλακτόνιος : **clactonian**
κλίση (της
επεξεργασίας) √ ανγλε (οφ
ρετουχη)
κογχοειδής : **conchoid**
κολόβωση : **truncation**
Κομπέουα (μέθοδος) :
Kombewa (method)
κορυφή : **crest**
κρουστήρας : **hammer**

κυματώσεις : **ripples**
κώνος : **cone**

λάξευση, λαξεμένος :
knapping, knapped
Λεβαλλουά (μέθοδος) :
Levallois (method)
λειασμένος : **polish**
λεία, επίπεδη (φτέρνα) :
flat, plain
λείανση : **polishing**
λείανση : **rubbed down**
λεμβοειδής θραύση :
nacelle
λεπίδα : **blade**
λεπίδα με κορυφή : **bladelet**
λογχοειδής ρωγμή : **hackle**
μερική (επεξεργασία) :
partial
μεσαίο (τμήμα) : **mesial**
μέθοδος : **method**
μέτωπο θραύσης : **fracture front**
μέτωπο ξέστρου :
end-scraper front
μικρογλυφίδα : **microburin**
μικρολεπίδα : **crested blade**
μίσχος : **tang**
μίσχος : **tang (long, narrow)**
μορφολογικός άξονας :
morphological axis
μορφολογία : **morphology**
μορφολογία απολέπισης :
removal morphology

νεύρωση : **arris**
νηματοειδής (φτέρνα) :
linear

οδοντωτός : **denticulated**
ορθή (επεξεργασία) : **direct**
όψη : **face**

παράλληλος : **parallel**
παρυφή : έρσαντ
πατίνα : **patina**
περίγραμμα : **delineation**
πίεση : **pressure**
πίεστρο : **punch**
πλευρά : **edge**
πλευρά λάξευσης :
trimmed edge
πλευρά με αποτόμη
επεξεργασία : **backed**
πολυεδρικός : **faceted**
προετοιμασία : **preparation**
προϊόντα απόκρουσης :
debitage products

προσανατολισμός :
orientation
προσχεδιάσμα : **roughout**
προσχέδιο : **preform**
πρόσθεμα : **addition**
πρωτότομο : **first flake**
πτερυγόσχημη φτέρνα :
winged
πυραμίδειο : **apex (of a pyramidal core)**
πυρηνοειδής : **core-like**
πυρήνας : **core**

θερμική διεργασία : **heat treatment**
θέση (επεξεργασίας) :
position
θλάση Σιρέτ, επιμήκης
θλάση : **Siret (accidental break)**
θραύση : **break**
θραύση : **fracture**
θρυμματισμός : **snap**

ραβδωτός : **channel-flaked**
ράχη : **back**
ράχη, με : **backed**
ρύγχος : **nose**
ρωγμή : **hackle**

σφυροκόπημα : **pecking**
σημείο κρούσης : **impact point**
σκαρίφημα : **sketch**
στιγμοειδής : **punctiform**
στίλβη : **gloss**
συμπιεστής : **crutch**
συναρμογή : **conjoining (flakes)**
συνεχής (επεξεργασία) :
continuous
σύντριμμα : **debris**

τεχνική : **technique**
τεχνική της κρούσης της
γλυφίδας : **burin blow technique**
τεχνική του κοπέα :
tranchet blow technique
τμήμα : **fragment**
τομή : **section**

υπέρβαση : **plunging**
υποπαράλληλη
(επεξεργασία) : **sub-parallel**
υπόβαθρο : **blank**

ώμος : **shoulder**

ξεχόντρισμα : **preliminary flaking**

ENGLISH : ITALIAN
translated by D. Zampetti

abrasion : **abrasione**
abrupt : **ripido(a)**
addition : **aggiunta**
alternate : **alterno**
alternating : **alternante**
angle (of retouch) :
inclinazione
angle de chasse : **angolo di rimozione**
anvil : **incudine**
apex (of a pyramidal core) :
sommità di un nucleo piramidale
arris : **nervatura**
atypical : **apico**

back : **dorso**
backed : **abbatuto**
base : **base**
bifacial : **bifacciale**
blade : **lama**
bladelet : **lamella**
blank : **supporto**
blunting : **smussato**
break : **frattura**
bulb : **bulbo**
bulb scars : **scagliatura del bulbo**
burin blow technique :
bulino (tecnica del colpo di)
burin facet : **faccia**
burin spall : **stacco di bulino**
burin tip : **dente del bulino**
butt : **tallone**

canted : **inclinato**
carène, carénage : **carena, carenaggio**
chapeau de gendarme :
capello di gendarme
cintrage : **curvatura**
clactonian : **clactoniano(a)**
conchoid : **concoide**
cone : **cono**
conjoining (flakes) : **raccordo**
continuous : **continuo(a)**
core : **nucleo**
core tablet, rejuvenation core
flake : **tavoletta di ravnivamento o di avvivamento**
core-like : **nucleiforme**
cortex : **cortice**
cortex removal :
decorticazione

cortical : **corticale**
cortical reserved zone :
riserva corticale
covering : **coprente**
crest : **cresta**
crested blade : **lama a cresta**
crossed : **incrociata**
crutch : **gruccia**

debitage : **scheggiatura**
debitage axis : **asse di scheggiatura**
debitage products : **prodotto di scheggiatura**
debris : **residuo**
delineation : **delineazione**
denticulated : **denticolato**
diacritical diagram : **schema diacritico**
dihedral : **diedro**
direct : **diretto(a)**
direction line : **striatura**
discontinuous :
discontinuo(a)
distal : **distale**
distribution : **ripartizione**

edge : **marginè**
end-scraper front : **fronte di grattatoio**
extent : **estensione**

face : **faccia**
facetted : **sfaccettato**
first flake : **scheggia corticale**
flake : **scheggia**
flaked surface : **superfici scheggiate**
flaking angle : **angolo di distacco**
flat, plain : **liscio(a)**
fluted : **scanalato**
fracture : **frattura**
fracture front : **fronte di frattura**
fragment : **frammento**

gloss : **lustrò**

hackle : **frattura a lancetta**
hammer : **percussore**
heat treatment : **trattamento termico**
hinged : **ripiegato, riflesso**

impact point : **punto d'impatto**
indirect : **indiretto(a)**

industry : **industria**
invasive : **invadente**
inverse : **inverso(a)**

Janus (flake) : Giano
(scheggia, see Kombewa)

knapping accident :
incidente di lavorazione
knapping, knapped :
lavorazione, lavorato(a)
Kombewa (method) :
Kombewa (metodo)

Levallois (method) :
Levallois (metodo)
linear : **lineare**
lip : **labbro**
localization : **localizzazione**
low angle : **radente**

mesial : **mediano(a)**
method : **metodo**
microburin : **microbulino**
morphological axis :
avvivamento
morphology : **morfologia**

nacelle : **navicella**
negative bulb : **negativo del bulbo**
negative of removal, scar :
negativo di un distacco
nose : **musò**
notch : **intaccatura**

orientation : **orientamento**
overhang : **cornice**

parallel : **parallelo(a)**
partial : **parziale**
patina : **patina**
pecking : **bocciardatura**
percussion : **percussione**
piquant-trièdre :
piquant-trièdre
plunging : **oltrepassato**
polished : **levigato(a)**
polishing : **levigatura**
position : **posizione**
preform : **preformato**
preliminary flaking :
sgrossatura
preparation : **preparazione**
pressure : **pressione**
pressure platform : **piano di pressione**
proximal : **prossimale**

punch : **punzione**
punctiform : **puntiforme**

refit(ting) : **rimontaggio, ricomposizione**
removal : **distacco**
removal morphology : **morfologia di un distacco**
resharpening : **ravvivamento**
retouch : **ritocco**
ridge : **spigolo**
ripples : **ondulazioni**
roughout : **abbozo**
rubbed : levigatura :

scaled : **a scaglie**
section : **sezione**
semi-abrupt : **semiripido**
shaping : **lavorazione**
shaping out : **messa in forma**
sharpening : **affilatura**
sharpening spall : **stacco di ravvivamento di un bulino**
shoulder : **spalla, cran**
Siret (accidental break) : **Siret (incidente)**
sketch : **schizzo**
spontaneous removal : **spontanei (distacchi)**
spur : **sperone**
stepped : **scalariforme**
striking platform : **piano di percussione**
sub-parallel : **sub-parallelo(a)**

tang (long, narrow) : **codolo**
tang : **pedonculo**
technique : **tecnica**
tongue : **linguetta**
tool : **strumento**
tranchet blow technique : **trincetto (colpo di)**
trimmed edge : **marginè lavorato**
truncation : **troncatura**

unmodify : **grezzo(a)**
unretouched : **grezzo(a) di lavorazione**
versant : **versante**

winged : **ala d'uccello (ad)**

ITALIAN : ENGLISH

a scaglie : **scaled**
abbatuto : **backed**

abbozzo : **roughout**
abrasione : **abrasion**
affilatura : **sharpening**
aggiunta : **addition**
ala d'uccello (ad) : **winged**
alternante : **alternating**
alterno : **alternate**
angolo di distacco : **flaking angle**
angolo di rimozione : **angle de chasse**
apico : **atypical**
asse di scheggiatura : **debitage axis**
avvivamento : **morphological axis**

base : **base**
bifacciale : **bifacial**
bocciardatura : **pecking**
bulbo : **bulb**
bulino (tecnica del colpo di) : **burin blow technique**

capello di gendarme : **chapeau de gendarme**
carena (carenaggio) : **carène, carénage**
clactoniano(a) : **clactonian**
codolo : **tang (long, narrow)**
concoide : **conchoid**
cono : **cone**
continuo(a) : **continuous**
coprente : **covering**
cornice : **overhang**
corticale : **cortical**
cortice : **cortex**
cran : **shoulder**
cresta : **crest**
curvatura : **cintrage**

decorticazione : **cortex removal**
delineazione : **delineation**
dente del bulino : **burin tip**
denticolato : **denticulated**
diedro : **dihedral**
diretto(a) : **direct**
discontinuo(a) : **discontinuous**
distacco : **removal**
distale : **distal**
dorso : **back**

estensione : **extent**

faccia : **burin facet**
faccia : **face**

frammento : **fragment**
frattura : **break**
frattura : **fracture**
frattura a lancetta : **hackle**
fronte di frattura : **fracture front**
fronte di grattatoio : **end-scraper front**

Giano : **Janus**
grezzo(a) : **unmodify**
grezzo(a) di lavorazione : **unretouched**
gruccia : **crutch**

incidente di lavorazione : **knapping accident**
inclinato : **canted**
inclinazione : **angle (of retouch)**
incrinatura : **snap**
incrociata : **crossed**
incudine : **anvil**
indiretto(a) : **indirect**
industria : **industry**
intaccatura : **notch**
invadente : **invasive**
inverso(a) : **inverse**

Kombewa (metodo) : **Kombewa (method)**

labbro : **lip**
lama : **blade**
lama a cresta : **crested blade**
lamella : **bladelet**
lavorazione : **shaping**
lavorazione, lavorato(a) : **knapping, knapped**
Levallois (metodo) : **Levallois (method)**
levigato(a) : **polished**
levigatura : **polishing**
levigatura : **rub**
lineare : **linear**
linguetta : **tongue**
liscio(a) : **flat, plain**
localizzazione : **localization**
lustro : **gloss**

marginè : **edge**
marginè abbatuto : **backed**
marginè lavorato : **trimmed edge**
mediano(a) : **mesial**
messa in forma : **shaping out**
metodo : **method**
microbulino : **microburin**

morfologia : **morphology**
morfologia di un distacco :
removal morphology
muso : **nose**

navicella : **nacelle**
negativo del bulbo : **negative bulb**

negativo di un distacco :
negative of removal, scar
nervatura : **arris**
nucleiforme : **core-like**
nucleo : **core**

oltrepassato : **plunging**
ondulazioni : **ripples**
orientamento : **orientation**

parallelo(a) : **parallel**
parziale : **partial**
patina : **patina**
pedonculo : **tang**
percussione : **percussion**
percussore : **hammer**
piano di percussione :
striking platform
piano di pressione : **pressure platform**
piquant-trièdre :
piquant-trièdre
posizione : **position**
preformato : **preform**
preparazione : **preparation**
pressione : **pressure**

prodotto di scheggiatura :
debitage products
prossimale : **proximal**
puntiforme : **punctiform**
punto d'impatto : **impact point**
punzone : **punch**

raccordo : **conjoining (flakes)**
radente : **low angle**
ravvivamento : **resharpening**
residuo : **debris**
riflesso, ripiegato : **hinged**
rimontaggio,
ricomposizione : **refitting**
ripartizione : **distribution**
ripido(a) : **abrupt**
riserva corticale : **cortical reserved zone**
ritocco : **retouch**

scagliatura del bulbo : **bulb scars**
scalariforme : **stepped**
scanalato : **fluted**
scheggia : **flake**
scheggia corticale : **first flake**
scheggiatura : **debitage**
schema diacritico :
diacritical diagram
schizzo : **sketch**
semiripido : **semi-abrupt**
sezione : **section**
sfaccettato : **facetted**

sgrossatura : **preliminary flaking**
Siret (incidente) : **Siret (accidental break)**
smussato : **blunting**
sommità di un nucleo piramidale : **apex (of a pyramidal core)**
spalla : **shoulder**
sperone : **spur**
spigolo : **ridge**
spontanei (distacchi) :
spontaneous removal
stacco di bulino : **burin spall**
stacco di ravvivamento di un bulino : **sharpening spall**
striatura : **direction line**
strumento : **tool**
sub-parallelo(a) : **sub-parallel**
superfici scheggiate : **flaked surface**
supporto : **blank**

tallone : **butt**
tavoletta di ravvivamento o di avvivamento : **core tablet, rejuvenation core flake**
tecnica : **technique**
trattamento termico : **heat treatment**
trincetto (colpo di) : **tranchet blow technique**
troncatura : **truncation**

versante : **versant**

ENGLISH :**PORTUGUESE**

translated by L. Raposo :

abrasion : **abrasão**abrupt : **abrupto(a)**addition : **acrescento**alternate : **alternativo**alternating : **alternante**

angle (of retouch) :

inclinação*angle de chasse* : **ângulo de lascamento**anvil : **bigorna**

apex (of a pyramidal core) :

vértice de pirâmidearris : **nervura**atypical : **atípico**back : **dorso**backed : **abatido**base : **base**bifacial : **bifacial**blade : **lâmina**bladelet : **lamela**blank : **suporte**blunting : **embotado, gasto**break : **fractura**bulb : **bolbo**bulb scars : **esquirolamento do bolbo**burin blow technique : **buril (técnica do golpe de)**burin facet : **faceta**burin spall : **resto de buril (resto característico resultante do golpe de buril)**burin tip : **bisel do buril**butt : **talão**canted : **inclinado***carène, carénage* : **carena (carenagem)***chapeau de gendarme* : **chapéu de gendarme***cintrage* : **arco,****arqueamento ou curvatura**clactonian : **clactonense**conchoid : **conchóide**cone : **cone**conjoining (flakes) : **junção**continuous : **contínuo(a)**core : **núcleo**

core tablet, rejuvenation core

flake : **placa or *tablette* de reavivamento ou de avivamento**core-like : **nucleiforme**cortex : **córtex**

cortex removal :

descorticaçãocortical : **cortical**

cortical reserved zone :

reserva corticalcovering : **cobridor(a)**crest : **crista**crested blade : **lâmina de****crista, ver crista**crossed : **cruzada**crutch : **muleta****compressora, pua****compressora**debitage : **debitagem**debitage axis : **eixo de****debitagem ou de lascamento**debitage products : **produto****de debitagem ou de****lascamento**debris : **resíduo**delineation : **delineação**denticulated : **denticulado**

diacritical diagram :

esquema diacríticodihedral : **diedro**direct : **directo(a)**direction line : **traço,****tracjado**

discontinuous :

descontínuo(a)distal : **distal**distribution : **repartição**edge : **bordo**end-scraper front : **frente de****raspadeira**extent : **extensão**face : **face**facetted : **facetado**first flake : **lasca inicial**flake : **lasca**flaked surface : **superfícies****debitadas, superfícies****lascadas**flaking angle : **ângulo de****extracção, ângulo externo**flat, plain : **liso(a)**fluted : **canelado(a),****adelgado(a) por meio de****canelura(s)**fracture : **fractura**fracture front : **frente de****fractura**fragment : **fragmento**gloss : **lustro**hackle : **lanceta**hammer : **percutor**heat treatment : **tratamento térmico, ver calor**hinged : **reflectido(a),****revertido(a)**impact point : **ponto de****impacto**indirect : **indirecto(a)**industry : **indústria**invasive : **invasor(a)**inverse : **inverso(a)**Janus (flake) : **Janus (lasca),****see Kombewa**knapping accident : **acidente de talhe**knapping, knapped : **talhe, talhado(a)**

Kombewa (method) :

Kombewa (método)

Levallois (method) :

Levallois (método)linear : **linear**lip : **lábio**localization : **localização**low angle : **rasante**mesial : **mesial**method : **método**microburin : **microburil**morphological axis : **eixo morfológico**morphology : **morfologia***nacelle* : **nacelle (fractura em forma de canoa)**negative bulb : **contra-bolbo**

negative of removal, scar :

negativo de levantamentonose : **focinho**notch : **entalhe**orientation : **orientação**overhang : **cornija**parallel : **paralelo(a)**partial : **parcial**patina : **pátina**pecking : **bojardagem**percussion : **percussão***piquant-trièdre* : **ápice****triédrico**plunging : **ultrapassado**

polished : **desgaste de polimento**
polishing : **polimento**
position : **posição**
preform : **pré-forma, pré-formatação**
preliminary flaking : **desbastamento, formatação inicial**
preparation : **preparação**
pressure : **pressão**
pressure platform : **plano de pressão**
proximal : **proximal**
punch : **punção, extractor de lâminas**
punctiform : **punctiforme**

refit(ting) : **remontagem**
removal : **levantamento**
removal morphology : **morfologia de um levantamento**
resharpening : **reavivamento**
retouch : **retoque**
ridge : **aresta**
ripples : **ondulações**
roughout : **esboço**
rubbed down : **areação, areado**

scaled : **escamoso(a)**
section : **secção**
semi-abrupt : **semi-abrupto**
shaping : **formatação, afeiçoamento**
shaping out : **conformação**
sharpening : **aguçamento**
sharpening spall : **resíduo de buril**
shoulder : **ombreira, ombro(em), crena**
Siret (accidental break) : **Siret (acidente)**
sketch : **esboço**
spontaneous removal : **espontâneos (levantamentos)**
spur : **esporão(em)**
stepped : **escalariforme**
striking platform : **plano de percussão ou de lascamento**
sub-parallel : **sub-paralelo(a)**

tang : **pedúnculo**
technique : **técnica**
tongue : **lingueta**
tool : **utensílio**

tranchet blow technique : **tranchet ou trinchete (golpe de)**
trimmed edge : **bordo talhado**
truncation : **truncatura**

unmodify : **bruto(a)**
unretouched : **bruto de debitagem ou de lascamento, (a) de talhe**

versant : **vertente, lado**

winged : **asa de pássaro (em)**

PORTUGUESE : ENGLISH

abatido : **backed**
abrasão : **abrasion**
abrupto(a) : **abrupt**
acidente de talhe : **knapping accident**
acrescento : **addition**
aguçamento : **sharpening**
alternante : **alternating**
alterno : **alternate**
ângulo de extracção, ângulo externo : **flaking angle**
ângulo de lascamento : **angle de chasse**
ápice triédrico : **piquant-trièdre**
arco, arqueamento ou curvatura : **cintrage**
areação, areado : **rubbed down**
aresta : **ridge**
arrancamento : **hackle**
asa de pássaro(em) : **winged**
atípico : **atypical**

base : **base**
bifacial : **bifacial**
bigorna : **anvil**
bisel do buril : **burin tip**
bojardagem : **pecking**
bolbo : **bulb**
bordo : **edge**
bordo abatido : **backed**
bordo talhado : **trimmed edge**
bruto(a) : **unmodify**
bruto de debitagem ou de lascamento, (a) de talhe : **unretouched**
buril (técnica do golpe de) : **burin blow technique**

canelado(a), adelgaçado(a) por meio de canelura(s) : **fluted**
carena (carenagem) : **carène, carénage**
chapéu de gendarme : **chapeau de gendarme**
clactonense : **clactonian**
cobridor(a) : **covering**
conchóide : **conchoid**
cone : **cone**
conformação : **shaping out**
contínuo(a) : **continuous**
contra-bolbo : **negative bulb**
cornija : **overhang**
córtex : **cortex**
cortical : **cortical**
crena, cran : **shoulder**
crista : **crest**
cruzada : **crossed**
debitagem : **debitage**

delineação : **delineation**
denticulado : **denticulated**
desbastamento, formatação inicial : **preliminary flaking**
descontínuo(a) : **discontinuous**
descorticamento : **cortex removal**
desgaste de polimento : **polished**
diedro : **dihedral**
directo (a) : **direct**
distal : **distal**
dorso : **back**

eixo de debitagem ou de lascamento : **debitage axis**
eixo morfológico : **morphological axis**
embotado, gasto : **blunting**
entalhe : **notch**
esboço : **roughout**
esboço, *croquis* : **sketch**
escalariforme : **stepped**
escamoso(a) : **scaled**
espigão : **tang (long, narrow)**
espontâneos (levantamentos) : **spontaneous removal**
esporão (em) : **spur**
esquema diacrítico : **diacritical diagram**
esquirolamento do bolbo : **bulb scars**
extensão : **extent**

face : **face**
faceta : **burin facet**
facetado : **facetted**
focinho : **nose**
formatação, afeiçoamento :
shaping
fractura : **break**
fractura : **fracture**
fragmento : **fragment**
frente de fractura : **fracture front**
frente de raspadeira :
end-scraper front

inclinação : **angle (of retouch)**
inclinado : **canted**
indirecto(a) : **indirect**
indústria : **industry**
invasor(a) : **invasive**
inverso(a) : **inverse**

Janus (lasca), see Kombewa :
Janus (flake)
junção : **conjoining (flakes)**

Kombewa (método) :
Kombewa (method)

lábio : **lip**
lamela : **bladelet**
lâmina : **blade**
lâmina de crista, ver crista :
crested blade
lanceta : **hackle**
lasca : **flake**
lasca inicial : **first flake**
Levallois (método) :
Levallois (method)
levantamento : **removal**
linear : **linear**
lingueta : **tongue**
liso(a) : **flat, plain**
localização : **localization**
lustro : **gloss**

mesial : **mesial**
método : **method**

microburil : **microburin**
morfologia : **morphology**
morfologia de um
levantamento : **removal morphology**
muleta compressora, pua
compressora : **crutch**

nacelle (fractura em forma
de canoa) : **nacelle**
negativo de levantamento :
negative of removal, scar
nervura : **arris**
nucleiforme : **core-like**
núcleo : **core**

ombreira, ombro (em) :
shoulder
ondulações : **ripples**
orientação : **orientation**

paralelo(a) : **parallel**
parcial : **partial**
pátina : **patina**
pedúnculo : **tang**
percussão : **percussion**
percutor : **hammer**
placa, *tablette* de
reavivamento, de
avivamento : **core tablet, rejuvenation core flake**
plano de percussão ou de
lascamento : **striking platform**
plano de pressão : **pressure platform**
polimento : **polishing**
ponto de impacto : **impact point**
posição : **position**
pré-forma, pré-formatação :
preform
preparação : **preparation**
pressão : **pressure**
produto de debitagem ou de
lascamento : **debitage products**
proximal : **proximal**

punção, extractor de
lâminas : **punch**
punctiforme : **punctiform**

rasante : **low angle**
reavivamento : **resharpening**
reflectido(a), revertido(a) :
hinged
remontagem : **refitting**
repartição : **distribution**
reserva cortical : **cortical reserved zone**
resíduo : **debris**
resíduo de buril : **sharpening spall**
resto de buril (resto
característico resultante do
golpe de buril) : **burin spall**
retoque : **retouch**

secção : **section**
semi-abrupto : **semi-abrupt**
Siret (acidente) : **Siret (accidental break)**
sub-paralelo(a) : **sub-parallel**
superfícies debitadas,
superfícies lascadas : **flaked surface**
suporte : **blank**

talão : **butt**
talhe, talhado(a) : **knapping, knapped**
técnica : **technique**
traço, tracejado : **direction line**
tranchet ou trinchete (golpe
de) : **tranchet blow technique**
tratamento térmico, ver
calor : **heat treatment**
truncatura : **truncation**

ultrapassado : **plunging**
utensílio : **tool**

vertente, lado : **versant**
vértice de pirâmide : **apex (of a pyramidal core)**

ENGLISH : SPANISH

translated by S. Ripoll

abrasion : **abrasión**abrupt : **abrupto(a)**addition : **añadido**alternate : **alterno**alternating : **alternante**

angle (of retouch) :

inclinación*angle de chasse* : **ángulo de expulsión**anvil : **yunque**apex (of a pyramidal core) : **piramidion (de núcleo)**arris : **nervadura**atypical : **atípico**back : **dorso**backed : **abatido**base : **base**bifacial : **bifacial**blade : **hoja**bladelet : **hojita**blank : **soporte**blunting : **romo**break : **fractura**bulb : **bulbo**bulb scars : **esquirlado del bulbo**burin blow technique : **buril (técnica del golpe de)**burin facet : **faceta**burin spall : **golpe de buril**burin tip : **diente de buril**butt : **talón**canted : **inclinado***carène, carénage* : **carena, carenado**channel-flaked : **aflautado(a)***chapeau de gendarme* :**chapeau de gendarme***cintrage* : **cimbreo**clactonian : **clactoniense**conchoid : **conoide**cone : **cono**

conjoining (flakes) :

remontajecontinuous : **continuo(a)**core : **núcleo**

core tablet, rejuvenation core

flake : **tableta de reavivado****o de avivado**core-like : **nucleiforme**cortex : **cortex**

cortex removal :

descortezadocortical : **cortical**

cortical reserved zone :

reserva corticalcortical zone : **playa cortical**covering : **cubriente**crest : **arista, cresta**crested blade : **hoja con****arista**crossed : **cruzado(a)**crutch : **muletilla (utilizada como compresor)**debitage : **talla**debitage axis : **eje de talla**debitage products : **producto de talla**debris : **debris**delineation : **delineación**denticulated : **denticulado**

diacritical diagram :

esquema diacríticodihedral : **diedro**direct : **directo(a)**direction line : **haces (de líneas)**

discontinuous :

discontinuo(a)distal : **distal**distribution : **repartición**edge : **borde**end-scraper front : **frente de raspador**extent : **extendido**face : **cara**facetted : **facetado**first flake : **lasca de****descortezado**flake : **lasca**flaked surface : **superficies talladas**flaking angle : **ángulo de****lascado**flat, plain : **liso**fluted : **acanalado (prismático)**fracture : **fractura**fracture front : **frente de fractura**fragment : **fragmento**gloss : **lustre**hackle : **lanceta (fractura en)**hammer : **percutor**heat treatment : **tratamiento térmico**hinged : **reflejado**impact point : **punto de impacto**indirect : **indirecto(a)**industry : **industria**invasive : **invasor**inverse : **inverso**Janus (flake) : **Jano (lasca, see Kombewa)**

knapping accident :

accidente de tallaknapping, knapped : **talla, tallado(a)**

Kombewa (method) :

Kombewa (método)

Levallois (method) :

Levallois (método)linear : **lineal**lip : **labio**localization : **localización**low angle : **rasante**mesial : **mesial**method : **método**microburin : **microburil**morphological axis : **eje morfológico**morphology : **morfología***nacelle* : **navecilla**negative bulb : **contra bulbo**

negative of removal, scar :

negativo de levantamientonose : **hocico**notch : **escotadura**orientation : **orientación**overhang : **cornisa**parallel : **paralelo**partial : **parcial**patina : **pátina**pecking : **abujardar**percussion : **percusión***piquant-trièdre* :**picantetriedro**plunging : **sobrepasado**polished : **pulido**polishing : **pulimento**position : **posición**preform : **conformado**

preliminary flaking :

desbastadopreparation : **preparación**pressure : **presión**

pressure platform : **plano de presión**
proximal : **proximal**
punch : **cinzel**
punctiform : **puntiforme**

refitting : **remontaje**
removal : **levantamiento**
removal morphology : **morfología de un levantamiento**
resharpening : **reavivado**
retouch : **retoque**
ridge : **nervadura**
ripples : **ondulaciones**
roughout : **esbozo**
rub (bed) down : **desgastar, desgastado**

scaled : **escamoso(a)**
section : **sección**
semi-abrupt : **semiabrupto**
shaping : **facetado**
shaping out : **puesta a punto**
sharpening : **aguzar, afilar**
sharpening spall : **recorte de buril**
shoulder : **muesca**
shoulder : **hombreira (en)**
Siret (accidental break) : **Siret (accidente de talla)**
sketch : **croquis**
snap : **rotura**
spontaneous removal : **espontáneos (levantamientos)**
spur : **espolón**
stepped : **escaleriforme**
striking platform : **plano de percusión**
sub-parallel : **subparalelo**

tang : **pedúnculo**
technique : **técnica**
tongue : **lengueta**
tool : **útil**
tranchet blow technique : **tranchet (golpe de)**
trimmed edge : **borde tallado**
truncation : **truncatura**
unmodify : **en bruto**

unretouched : **soporte en bruto, talla en bruto**

versant : **vertiente**

winged : **ala de pajaroen forma de)**

SPANISH : ENGLISH

abatido : **backed**
abrasión : **abrasion**
abrupto(a) : **abrupt**
abujardar : **pecking**
acanalado (prismático) : **fluted**
accidente de talla : **knapping accident**
aflautado(a) : **channel-flaked**
aguzar, afilar : **sharpening**
ala de pajaroen forma de) : **winged**
alternante : **alternating**
alterno : **alternate**
añadido : **addition**
ángulo de expulsión : **angle de chasse**
ángulo de lascado : **flaking angle**
arista, cresta : **crest**
atípico : **atypical**

base : **base**
bifacial : **bifacial**
borde : **edge**
borde abatido : **backed**
borde tallado : **trimmed edge**
bulbo : **bulb**
buril (técnica del golpe de) : **burin blow technique**

cara : **face**
carena (carenado) : **carène, carénage**
chapeau de gendarme : **chapeau de gendarme**
cimbreo : **cintrage**
cinzel : **punch**
clactoniense : **clactonian**
conformado : **preform**
cono : **cone**
conoide : **conchoid**
continuo(a) : **continuous**
contra bulbo : **negative bulb**
cornisa : **overhang**
cortex : **cortex**
cortical : **cortical**
croquis : **sketch**
cruzado(a) : **crossed**
cubriente : **covering**

debris : **debris**

delineación : **delineation**
denticulado : **denticulated**
desbastado : **preliminary flaking**
descortezado : **cortex removal**
desgastar, desgastado : **rub**
diedro : **dihedral**
diente de buril : **burin tip**
directo(a) : **direct**
discontinuo(a) : **discontinuous**
distal : **distal**
dorso : **back**

eje de talla : **debitage axis**
eje morfológico : **morphological axis**
en bruto : **unmodify**
esbozo : **roughout**
escaleriforme : **stepped**
escamoso(a) : **scaled**
escotadura : **notch**
espolón : **spur**
espontáneos (levantamientos) : **spontaneous removal**
esquema diacrítico : **diacritical diagram**
esquirlado del bulbo : **bulb scars**
extendido : **extent**

faceta : **burin facet**
facetado : **facetted**
facetado : **shaping**
fractura : **break**
fractura : **fracture**
fractura en lanceta : **hackle**
fragmento : **fragment**
frente de fractura : **fracture front**
frente de raspador : **end-scraper front**

golpe de buril : **burin spall**

haces (de líneas) : **direction line**
hocico : **nose**
hoja : **blade**
hoja con arista : **crested blade**
hojita : **bladelet**
hombreira (en) : **shoulder**

inclinación : **angle (of retouch)**

inclinado : **canted**
indirecto(a) : **indirect**
industria : **industry**
invasor : **invasive**
inverso : **inverse**

Jano (lasca) : **Janus (flake)**,
see **Kombewa**

Kombewa (método) :
Kombewa (method)

labio : **lip**
lanceta (fractura en) : **hackle**
lasca : **flake**
lasca de descortezado : **first flake**
lengueta : **tongue**
Levallois (método) :
Levallois (method)
levantamiento : **removal**
lineal : **linear**
liso : **flat, plain**
localización : **localization**
lustre : **gloss**

mesial : **mesial**
método : **method**
microburil : **microburin**
morfología : **morphology**
morfología de un
levantamiento : **removal morphology**
muesca : **shoulder**
muletilla (utilizada como
compresor) : **crutch**

navecilla : **nacelle**
negativo de levantamiento :
negative of removal, scar
nervadura : **arris**

nervadura : **ridge**
nucleiforme : **core-like**
núcleo : **core**

ondulaciones : **ripples**
orientación : **orientation**

paralelo : **parallel**
parcial : **partial**
pátina : **patina**
pedúnculo : **tang**
percusión : **percussion**
percutor : **hammer**
picantetriedro :
piquant-trièdre
piramidión (de núcleo) :
apex (of a pyramidal core)
plano de percusión : **striking platform**
plano de presión : **pressure platform**
playa cortical : **cortical zone**
posición : **position**
preparación : **preparation**
presión : **pressure**
producto de talla : **debitage products**
proximal : **proximal**
puesta a punto : **shaping out**
pulido : **polished**
pulimento : **polishing**
puntiforme : **punctiform**
punto de impacto : **impact point**

rasante : **low angle**
reavivado : **resharpening**
recorte de buril : **sharpening spall**
reflejado : **hinged**

remontaje : **conjoining (flakes)**
remontaje : **refitting**
repartición : **distribution**
reserva cortical : **cortical reserved zone**
retoque : **retouch**
romo : **blunting**
rotura : **snap**

sección : **section**
semiabrupto : **semi-abrupt**
Siret (accidente de talla) :
Siret (accidental break)
sobrepasado : **plunging**
soporte : **blank**
soporte en bruto, talla en
bruto : **unretouched**
subparalelo : **sub-parallel**
superficies talladas : **flaked surface**

tableta de reavivado o de
avivado : **core tablet, rejuvenation core flake**
talla : **debitage**
talla, tallado(a) : **knapping, knapped**
talón : **butt**
técnica : **technique**
tranchet (golpe de) :
tranchet blow technique
tratamiento térmico : **heat treatment**
truncatura : **truncation**

útil : **tool**

vertiente : **versant**

yunque : **anvil**

L O U I S - J E A N
avenue d'Embrun, 05003 GAP cedex
Tél. : 04.92.53.17.00
Dépôt légal : 461 — Juin 1999
Imprimé en France

