

**ΜΟΝΟΠΤΕΡΟΣ ΚΑΙ
ΘΗΣΑΥΡΟΣ ΣΙΚΥΩΝΙΩΝ**



Το μονόπτερο κτίσμα είχε διαστάσεις 4 επί 5 και οι 14 κίονές του, μονολιθικοί και με ύψος 2,78 μ. στήριζαν την οροφή απευθείας, χωρίς τη μεσολάβηση τοίχων. Η ζωφόρος του επιστυλίου ήταν διακοσμημένη με ανάγλυφο με θέματα ηρωικά, που χρονολογούνται γύρω στο 560 π.Χ. Η όλη κατασκευή θυμίζει στέγαστρο για κάποιο πολύτιμο και ευπαθές ανάθημα. Έχει διατυπωθεί η ελκυστική θεωρία ότι ο μονόπτερος στέγαζε το άρμα με το οποίο ο Κλεισθένης κέρδισε την αρματοδρομία στα πρώτα [Πύθια](#) του 582 π.Χ.



ΜΟΝΟΠΤΕΡΟΣ ΣΙΚΥΩΝΙΩΝ



ΜΟΝΟΠΤΕΡΟΣ . ΜΕΤΟΠΕΣ

1. ΔΙΟΣΚΟΥΡΟΙ
2. ΑΠΑΓΩΓΗ ΕΥΡΩΠΗΣ
3. Η ΑΡΓΩ
4. ΚΑΛΥΔΩΝΙΟΣ ΚΑΠΡΟΣ

ΘΗΣΑΥΡΟΣ ΣΙΚΥΩΝΙΩΝ

Σύμφωνα με την επικρατέστερη άποψη, ο θησαυρός ανεγέρθηκε από τους πολίτες της Σικυώνας που ανέτρεψαν την οικογένεια του Κλεισθένη, χρησιμοποιώντας οικοδομικό υλικό από τα δύο προγενέστερα μνημεία, που κατέστρεψαν εσκεμμένα.

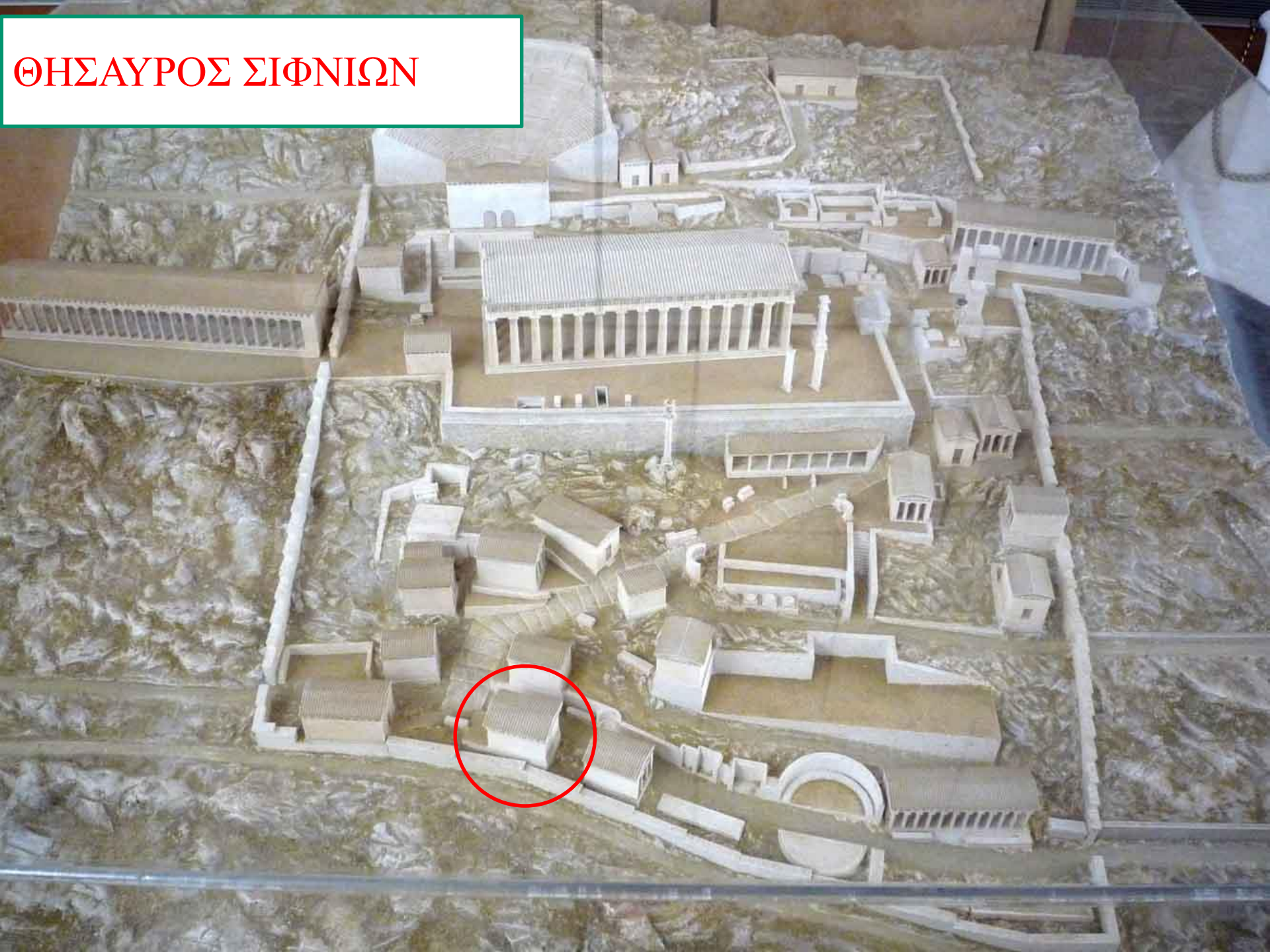


ΘΟΛΟΣ ΤΩΝ ΣΙΚΥΩΝΙΩΝ ΣΤΟΥΣ ΔΕΛΦΟΥΣ





ΘΗΣΑΥΡΟΣ ΣΙΦΝΙΩΝ



ΘΗΣΑΥΡΟΣ ΣΙΦΝΙΩΝ



ΘΗΣΑΥΡΟΣ ΣΙΦΝΙΩΝ









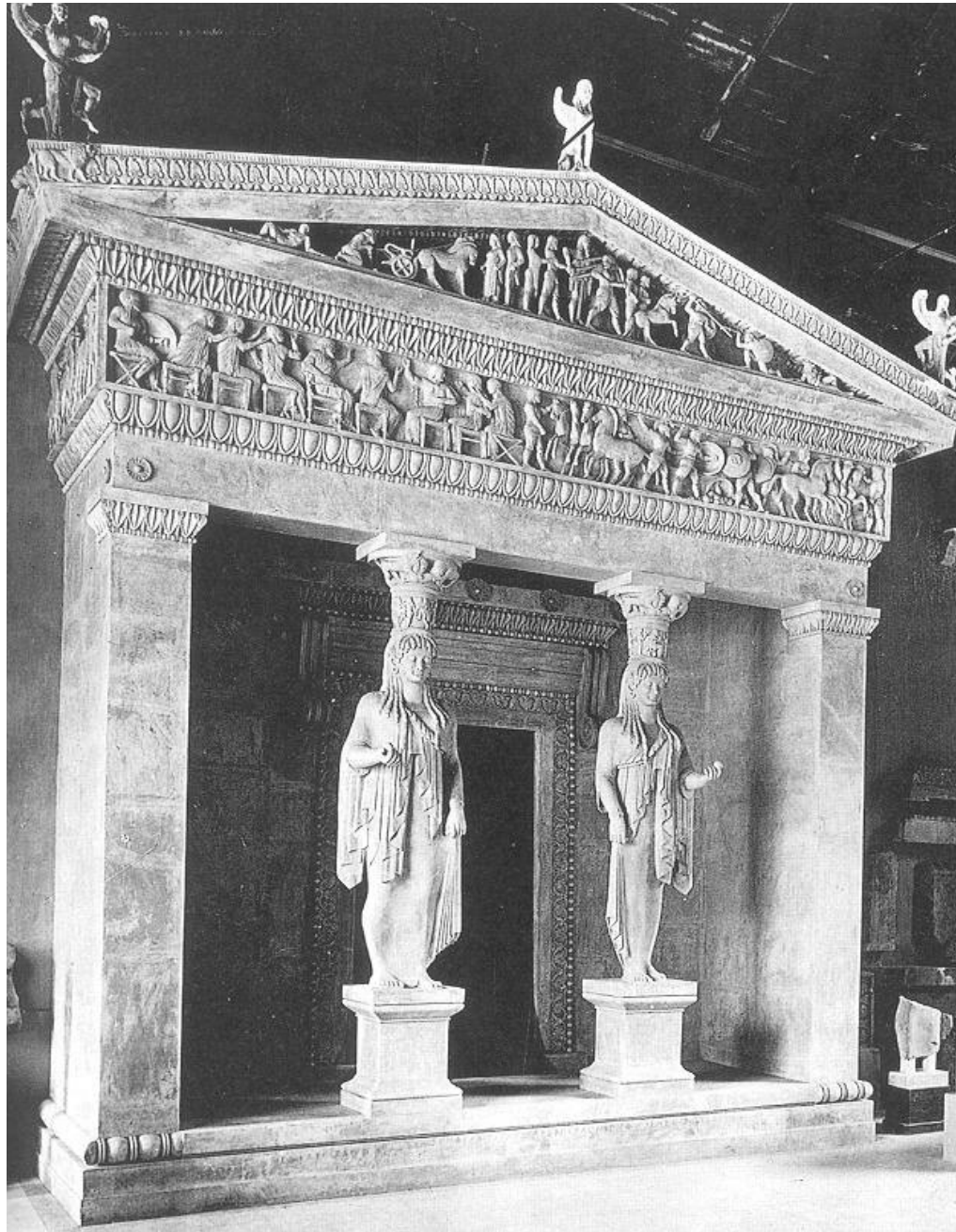


© e-sifnos.com











ΑΓΟΡΑ ΘΕΩΝ



20

21

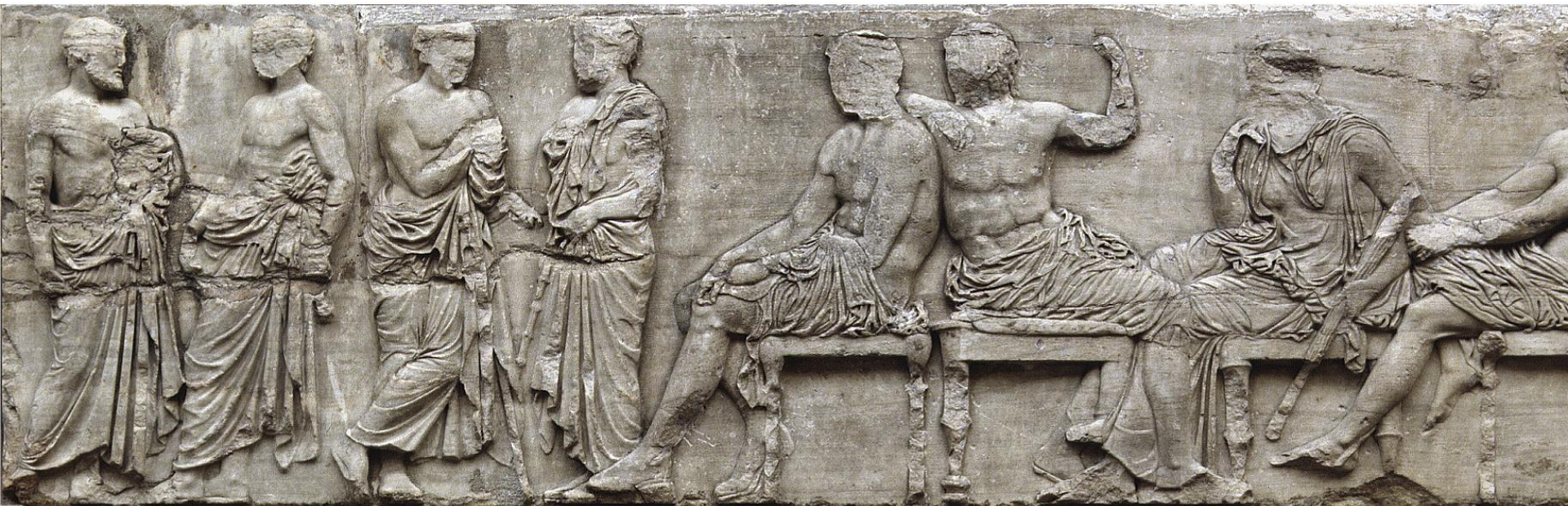
22

23

24

25

26



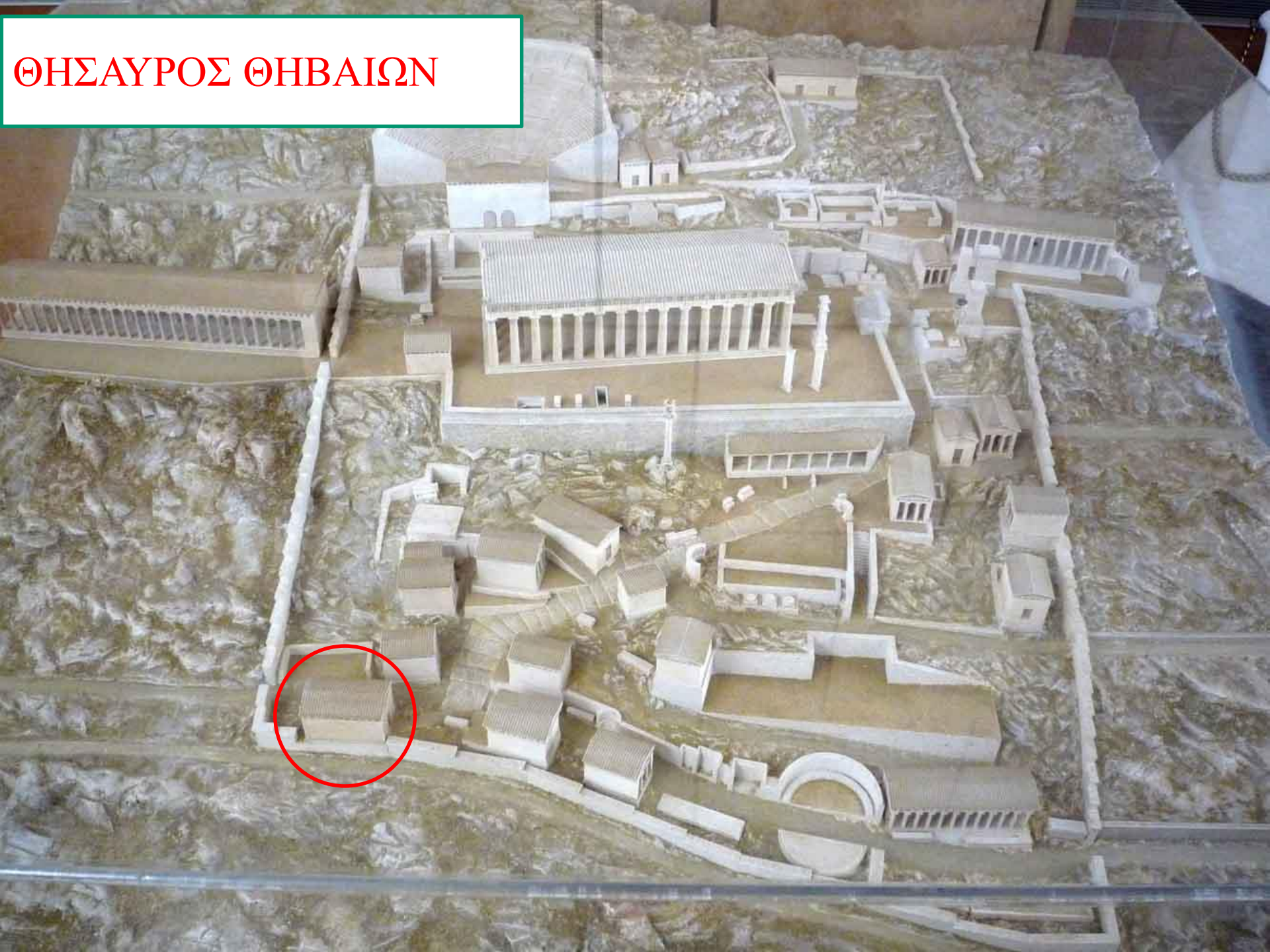


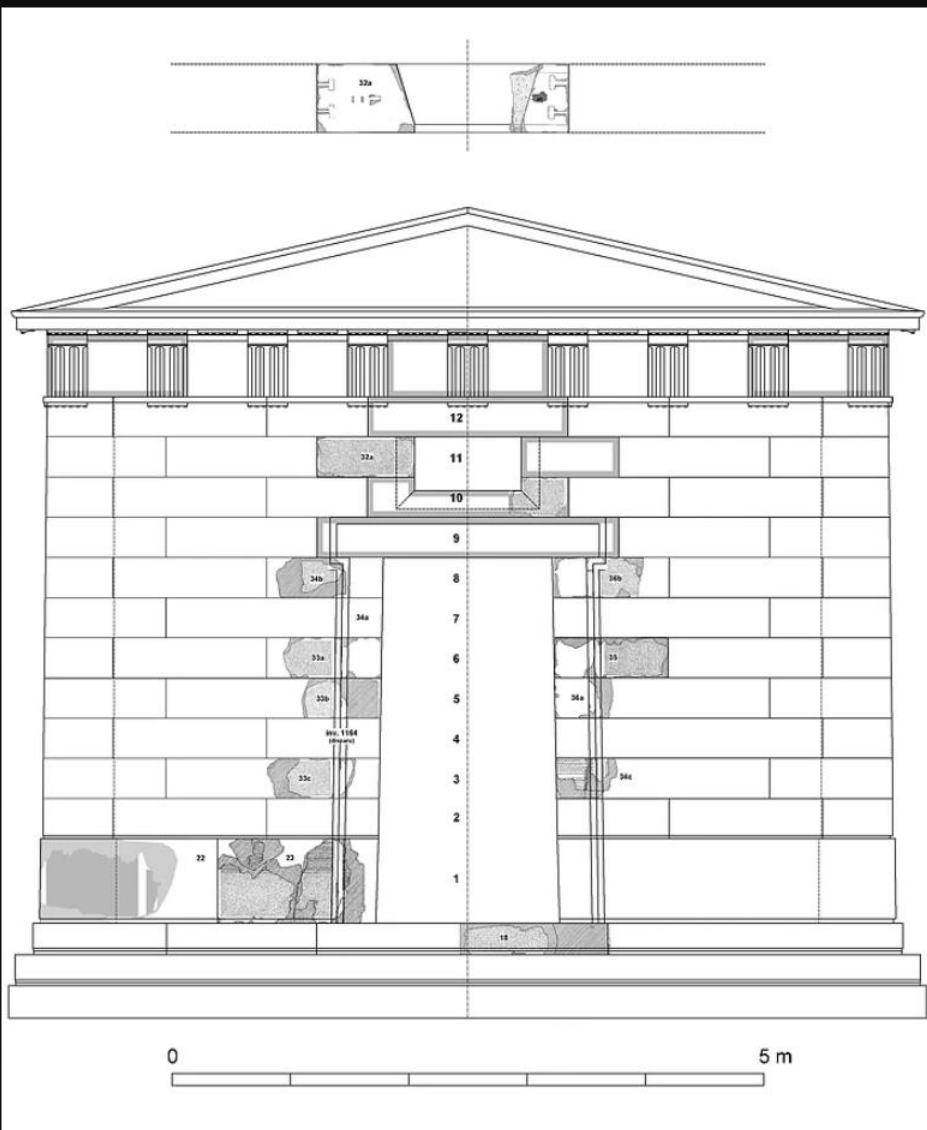
gettyimages®
De Agostini / Archivio J. Lange

588945581



ΘΗΣΑΥΡΟΣ ΘΗΒΑΙΩΝ





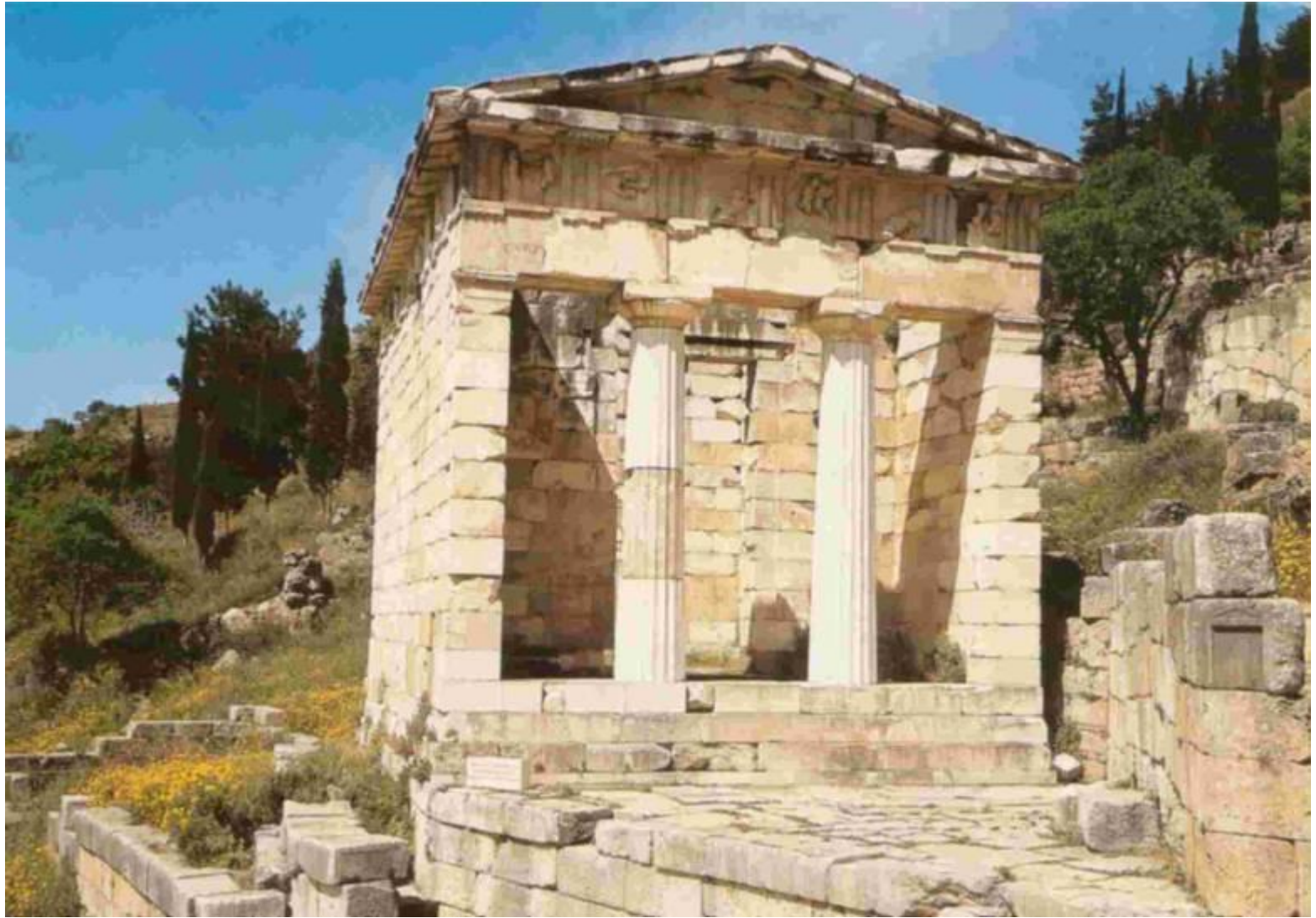
ΘΗΣΑΥΡΟΣ ΘΗΒΑΙΩΝ



ΘΗΣΑΥΡΟΣ ΑΘΗΝΑΙΩΝ





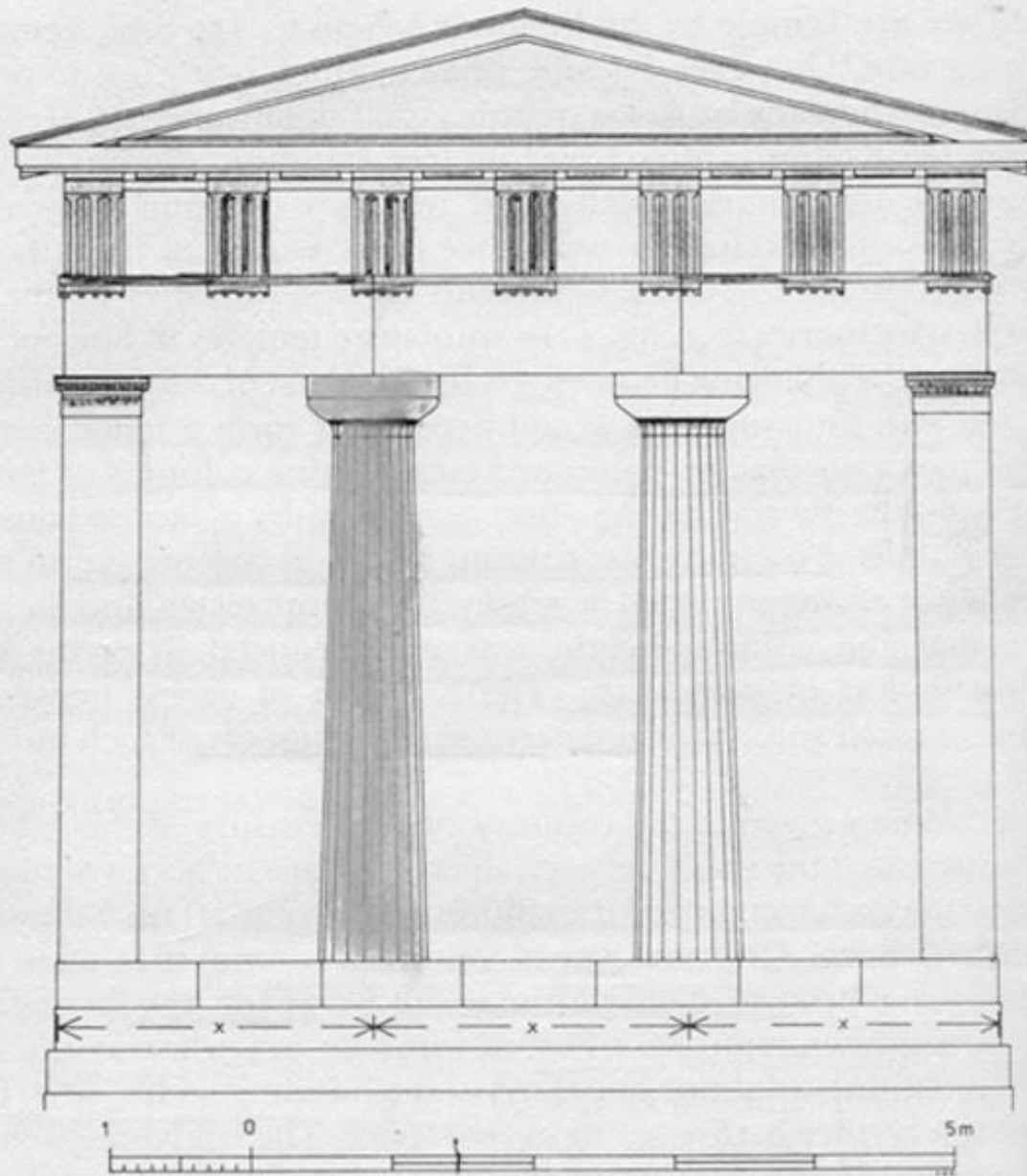








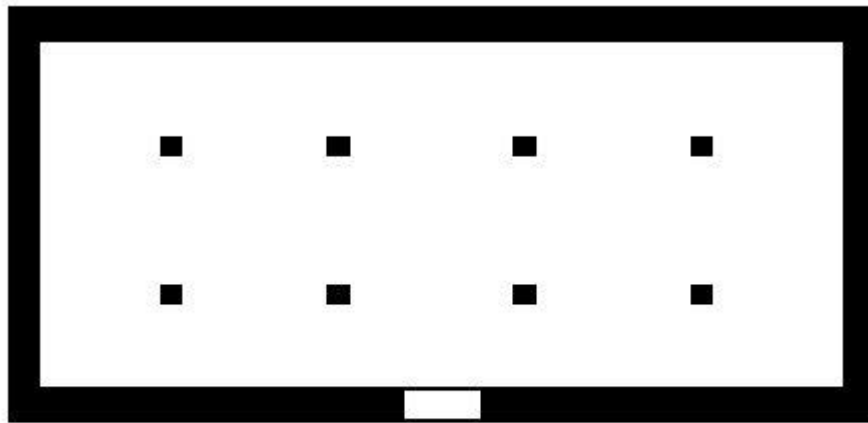
GREEK ARCHITECTS AT WORK



ΛΕΣΧΗ ΚΝΙΔΙΩΝ







0 10 m.



ΛΕΣΧΗ ΚΝΙΔΙΩΝ



ΠΟΛΥΓΝΩΤΟΣ Ο ΘΑΣΙΟΣ, ο ηθογράφος

- Πausανίας, 1892/1893 C. Robert
- Ιλιάδα, Οδύσσεια





ΘΗΣΑΥΡΟΣ ΚΥΡΗΝΑΙΩΝ



ΘΗΣΑΥΡΟΣ ΚΥΡΗΝΑΙΩΝ



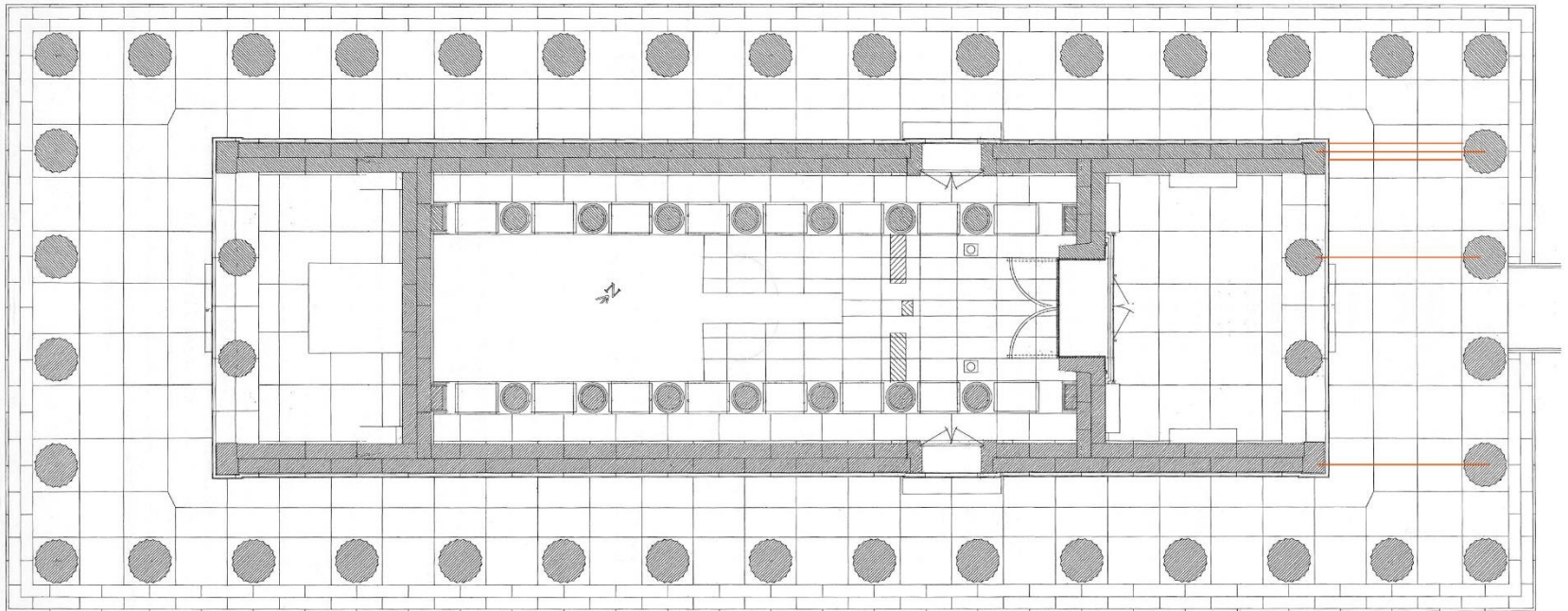


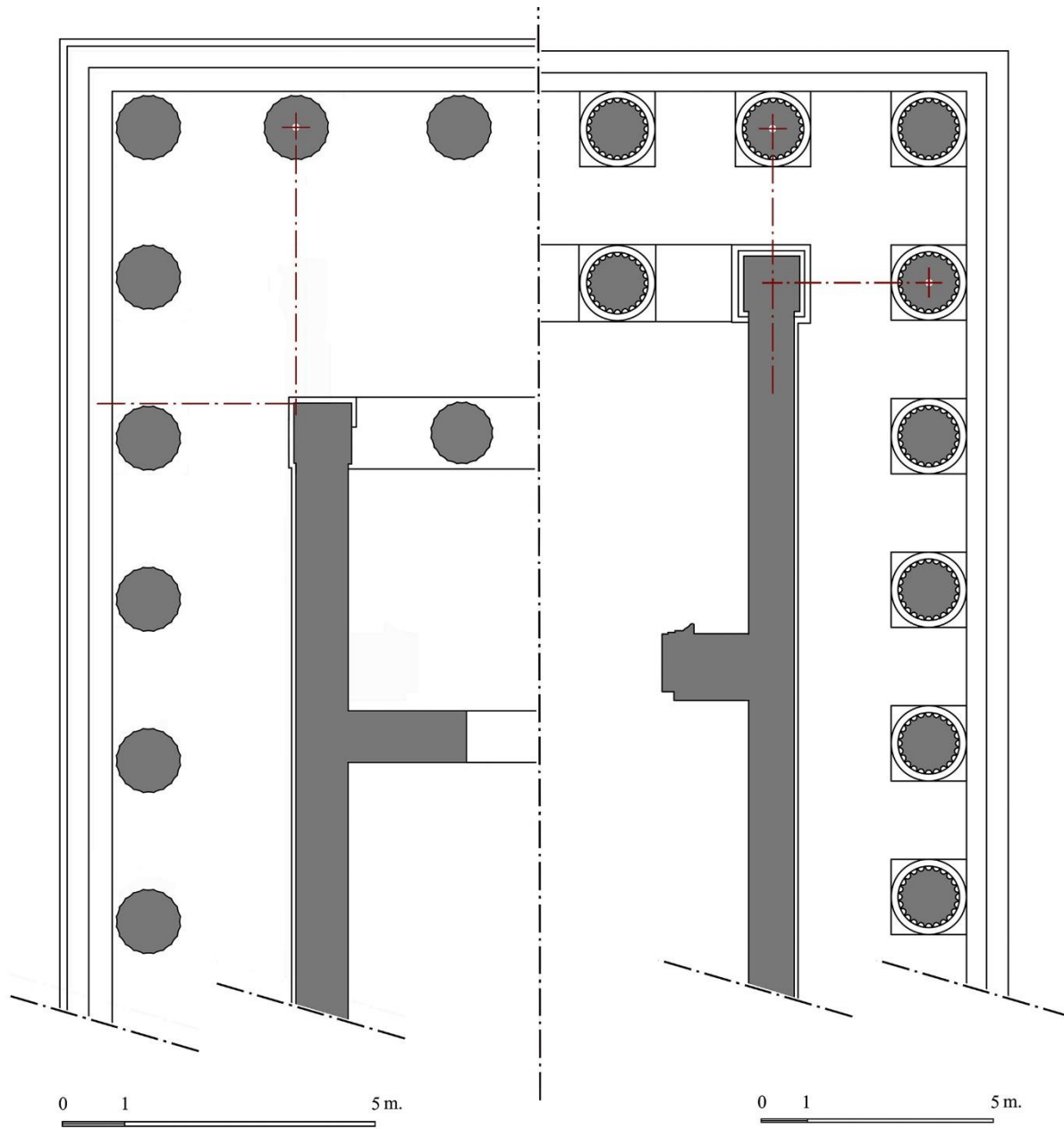


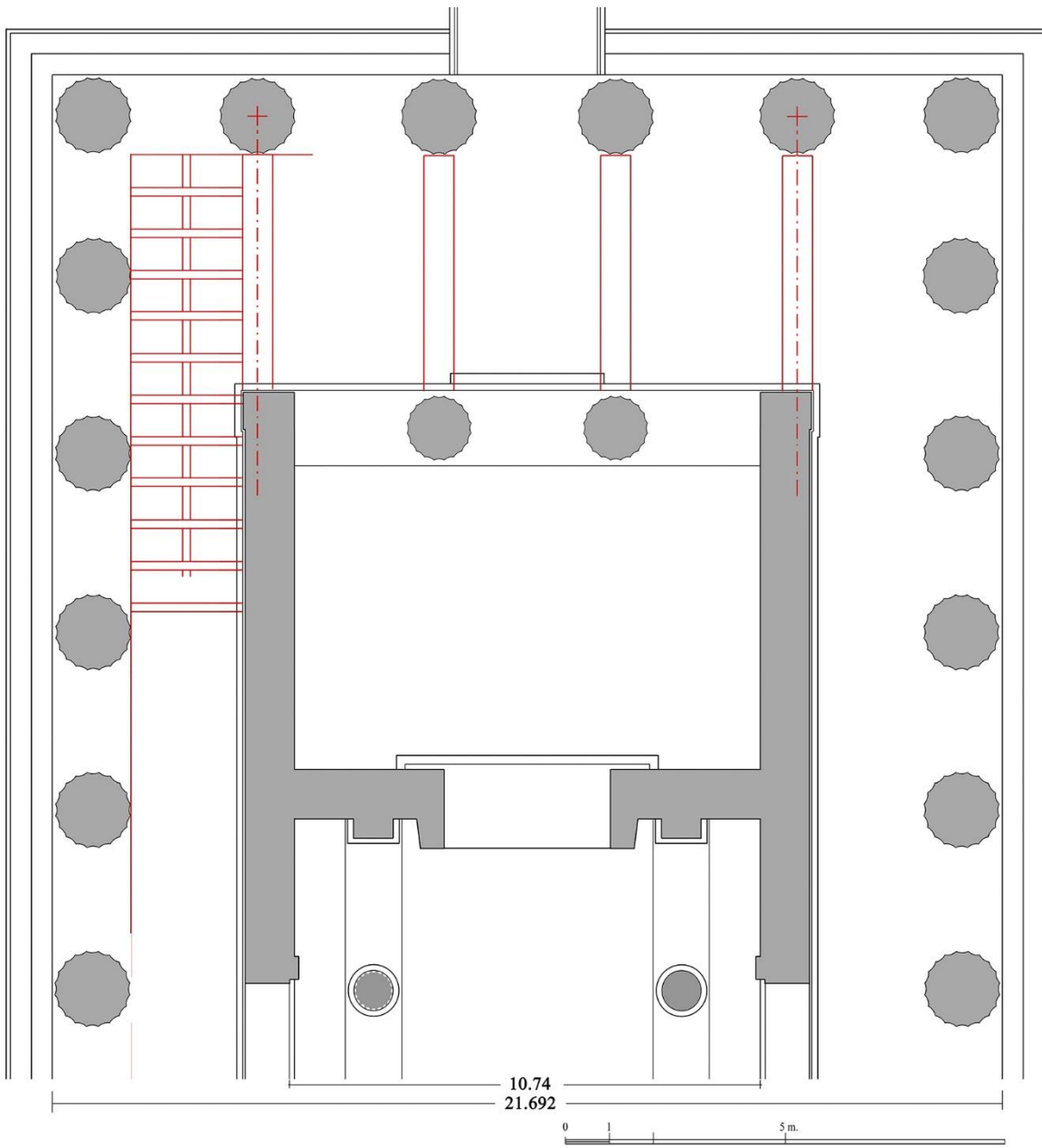




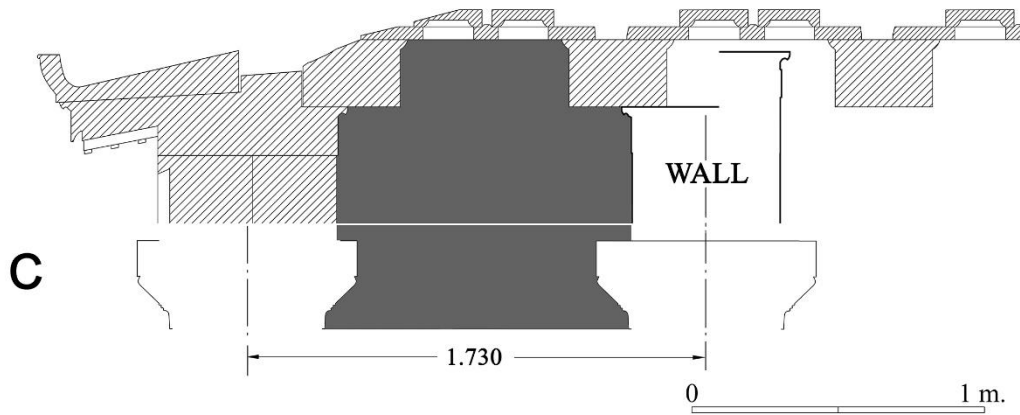
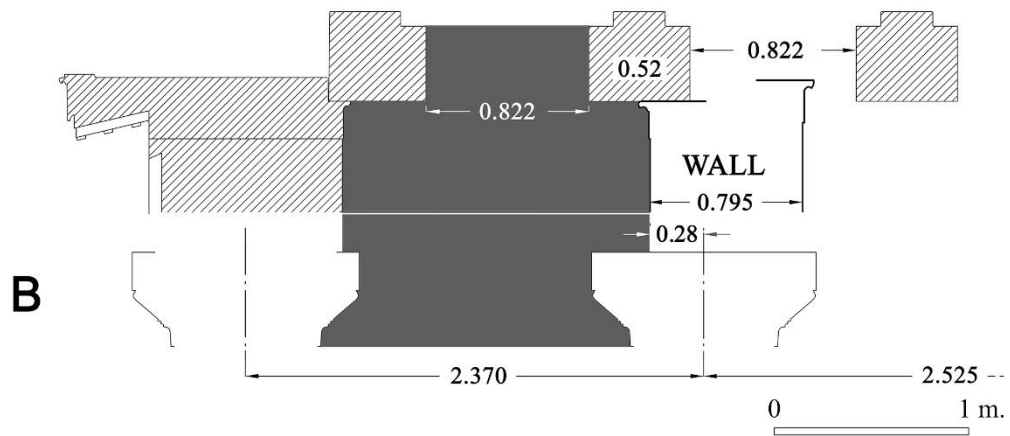
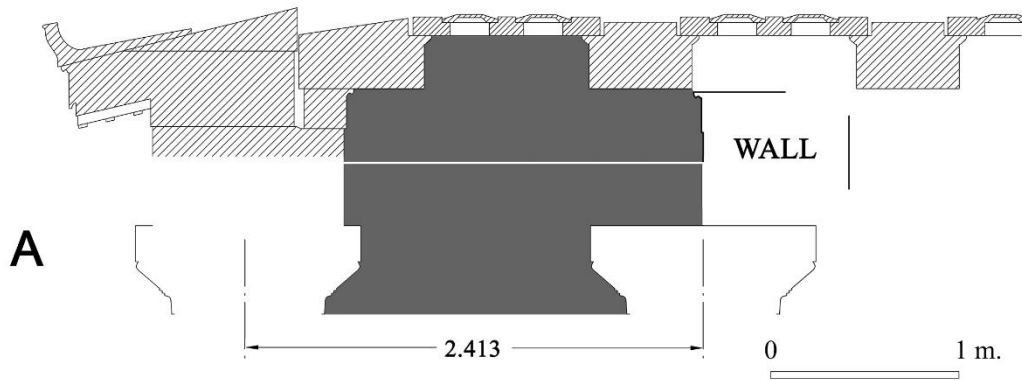
Fig. 18.19. Plan, Restitution éch. 1/225.

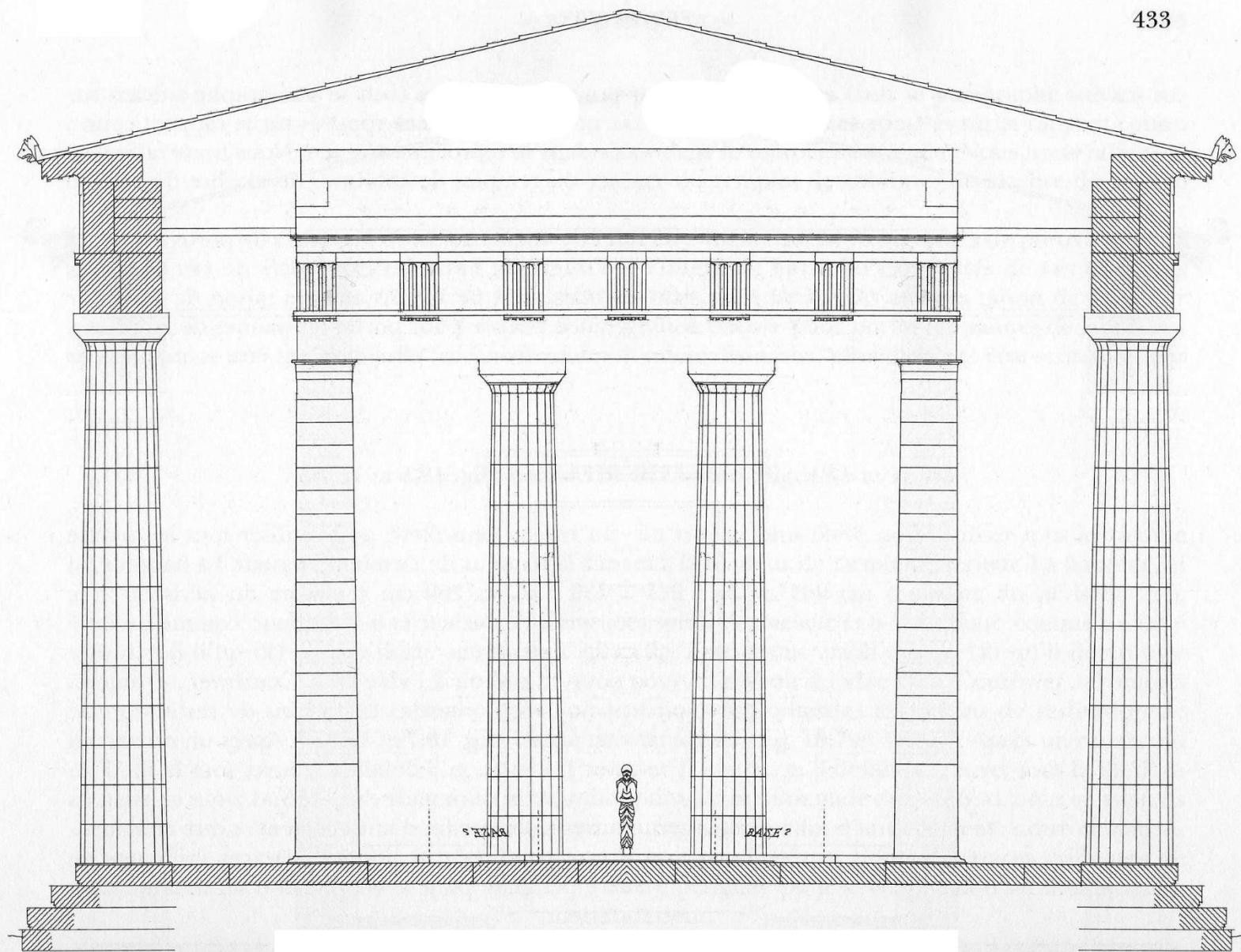












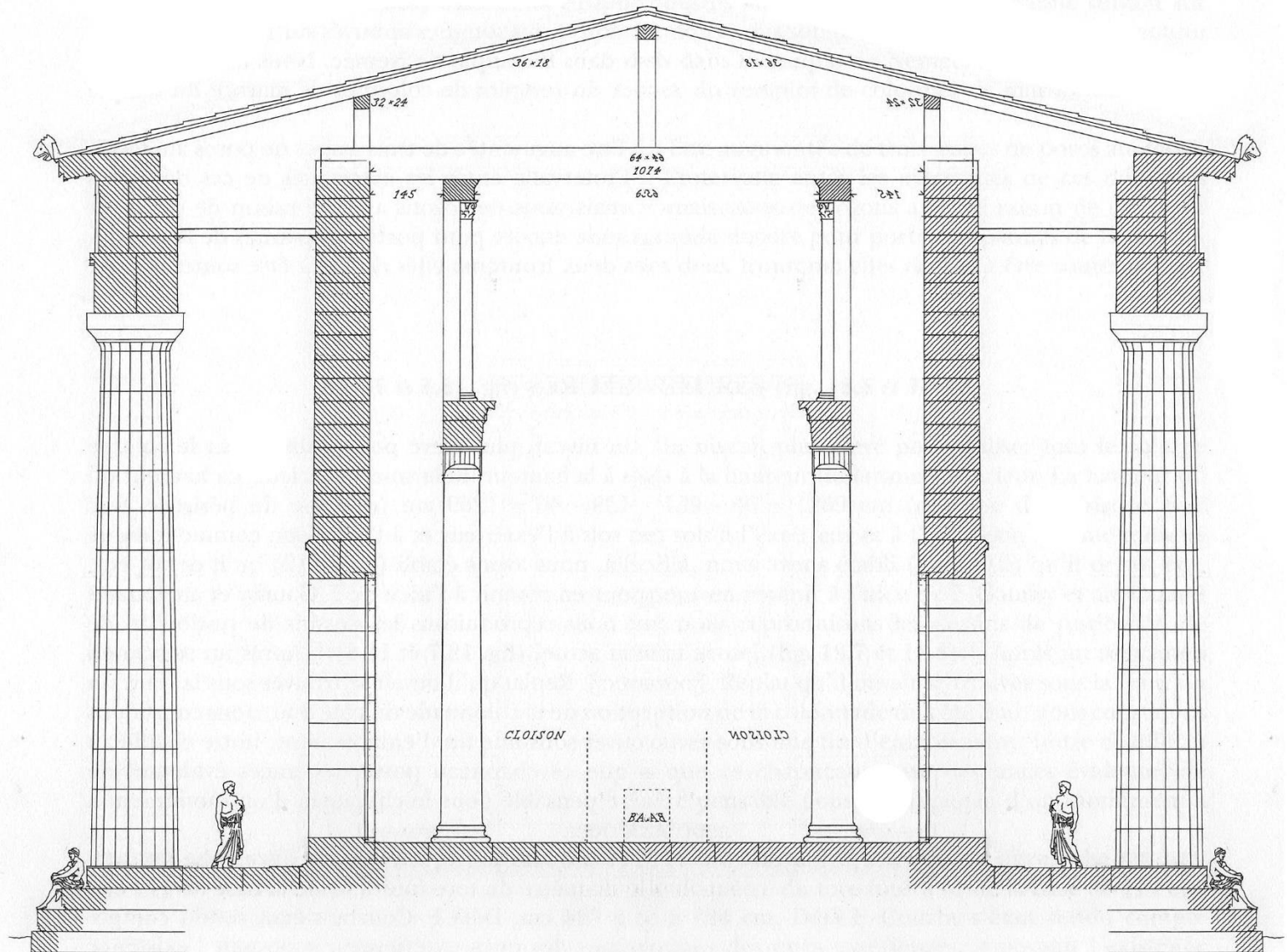


Fig. 18.5. Coupe sur la cella, avec les portes latérales. Essai de restitution éch. 1/125. Les détails des colonnades intérieures sont hypothétiques et la restitution de la charpente est fondée essentiellement sur des calculs de statique. Les mesures sont exprimées en cm.

Ancient Delphi



Sanctuary of Apollo

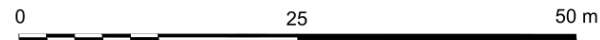
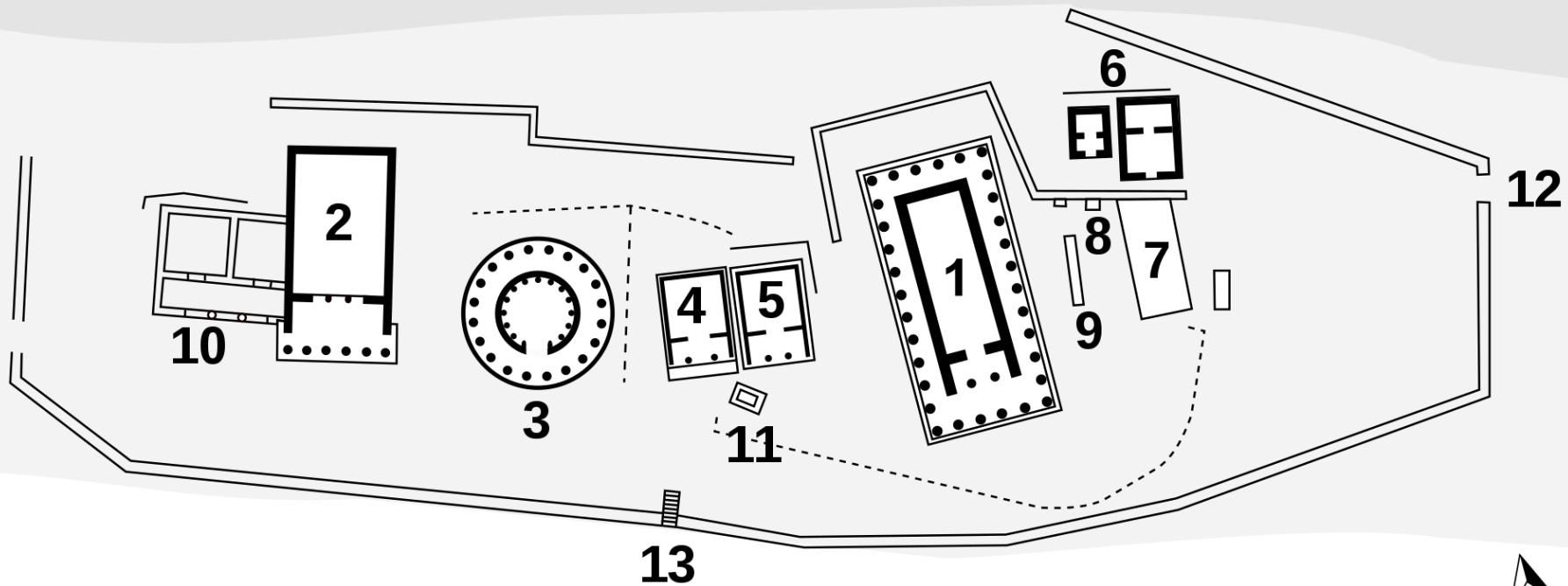


Αναπαράσταση της ρωμαϊκής Αγοράς. • Reconstruction of the roman Agora. • Restitution de l' Agora romaine. (D. Laroche, EFA)



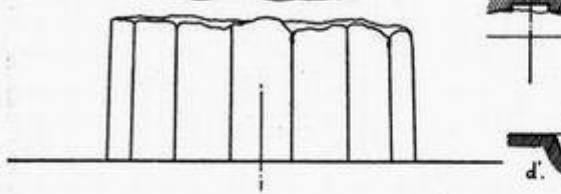












www.shutte

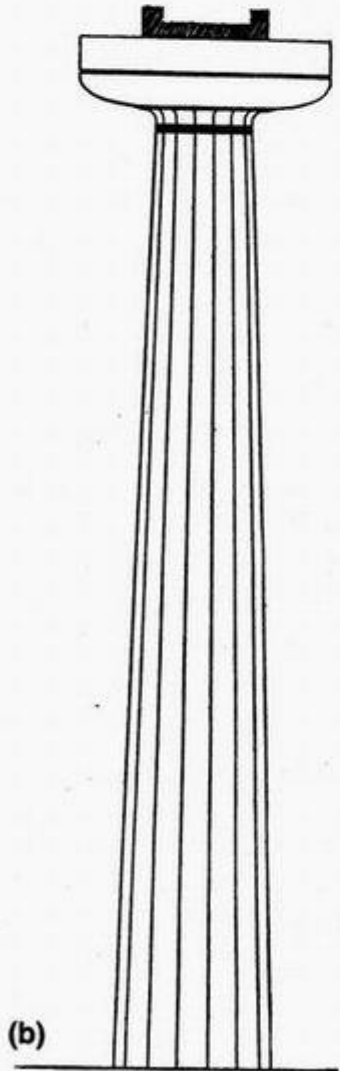


Figure 26. (a) Capital of the Temple of Athena Pronaia, Delphi, from R. Demangel, *Les Temples de tuf, FdD II: Topographie et Architecture, 3: Le Sanctuaire d'Athéna Pronaia 1* (Paris: de Boccard, 1923) pl. 13, reproduced by permission of the French School in Athens (École Française d'Athènes), (b) Reconstructed column of the Temple of Athena Pronaia, Delphi, from D.S. Robertson, *Greek and Roman Architecture*, (London: Cambridge University Press, 1974) 65, fig. 25, reprinted with the permission of Cambridge University Press.



Il y a donc des fortes probabilités pour que ce soit bien un temple mycénien, et non pas un temple d'Athènes. Or, comme il est situé à un niveau supérieur à celui de l'époque « mycénienne »¹, et qu'il n'a été découvert, entre ses pierres, aucun objet certainement antérieur à la période archaïque², on a pensé avoir retrouvé un des longs murs du premier temple en tuf.

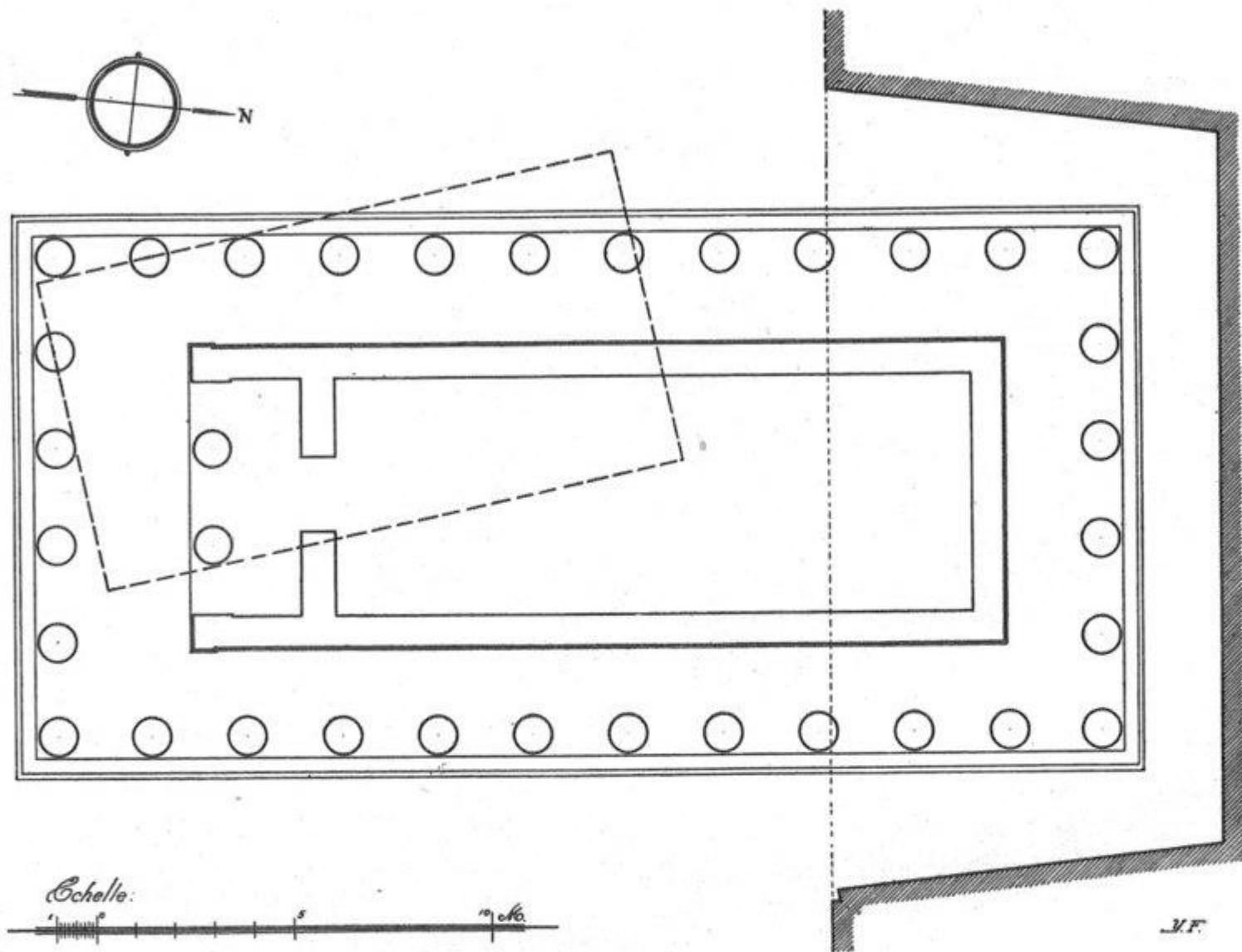


Fig. 47. — Position hypothétique du premier temple en tuf.

B' ΝΑΟΣ ΑΘΗΝΑΣ

After the destruction of temple A another temple, now called temple B, was erected on the same spot. The date of its construction is estimated at c. 510 BC, and it probably formed part of the building program of the Alcmaeonids for the restoration of the monuments of Delphi. This second temple (13.25 × 27.46 m) was also made of porous stone. It did not have an opisthodomos; its pteron consisted of **12 columns** on the long sides and 6 columns on the narrow ones. Its metopes were made of clay, decorated with figures; the pediments and acroteria also bore figures, such as Athena (pediment) and Nike (side acroteria). The temple was excavated towards the end of the "Grande Fouille". Fifteen columns were still standing in 1905, when a rock fall destroyed them. Scholars think that perhaps this second temple was never actually destroyed or abandoned but continued to function after the construction of the third temple. The marble fragments of a head of Athena discovered and displayed now at the museum are attributed to the cult statue of Athena, which would have been situated in the cella of the temple.^[2]

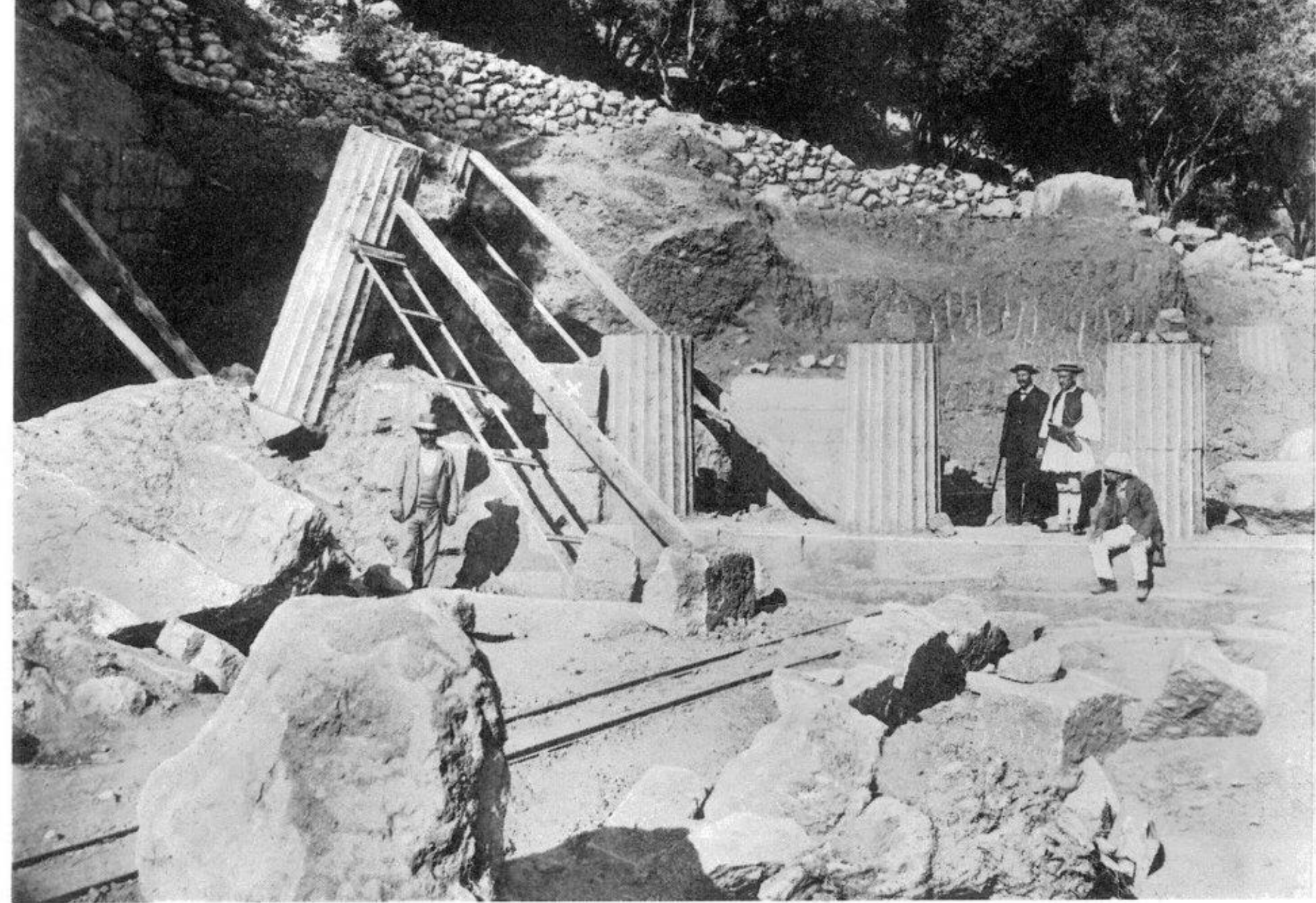


Fig. 3. - État des fouilles en 1901.



Fig. 6. - Les colonnes du temple en tuf avant 1905.

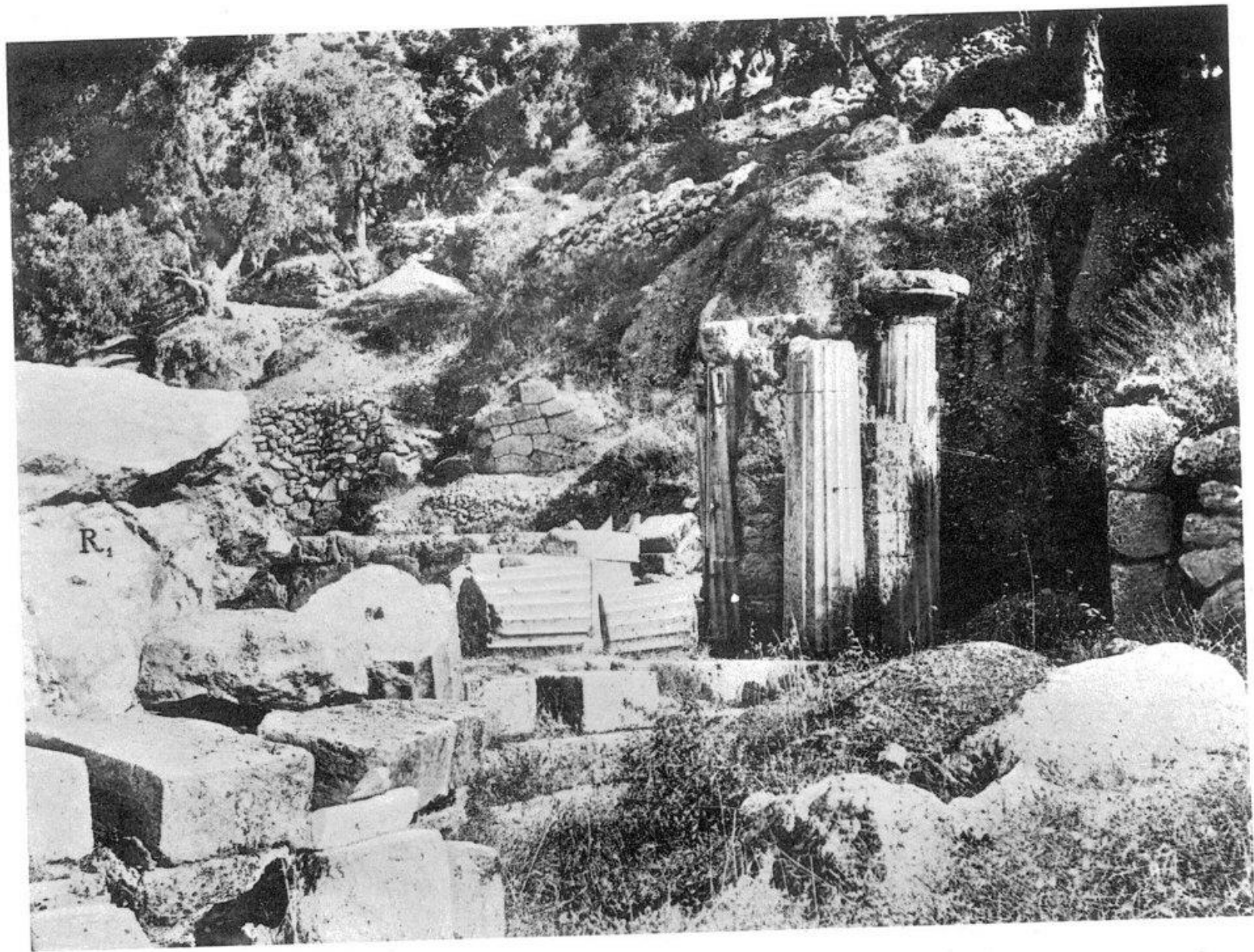
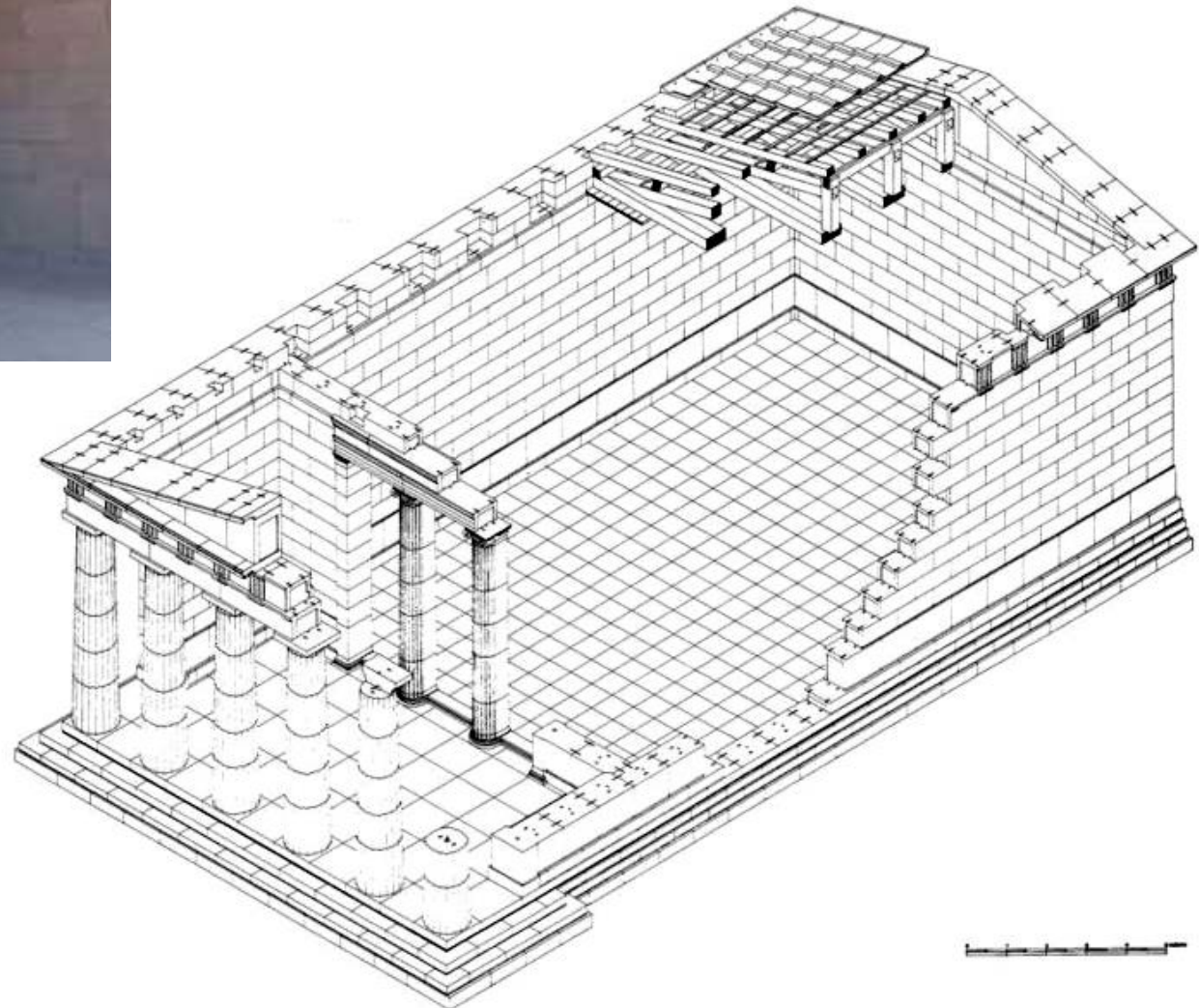


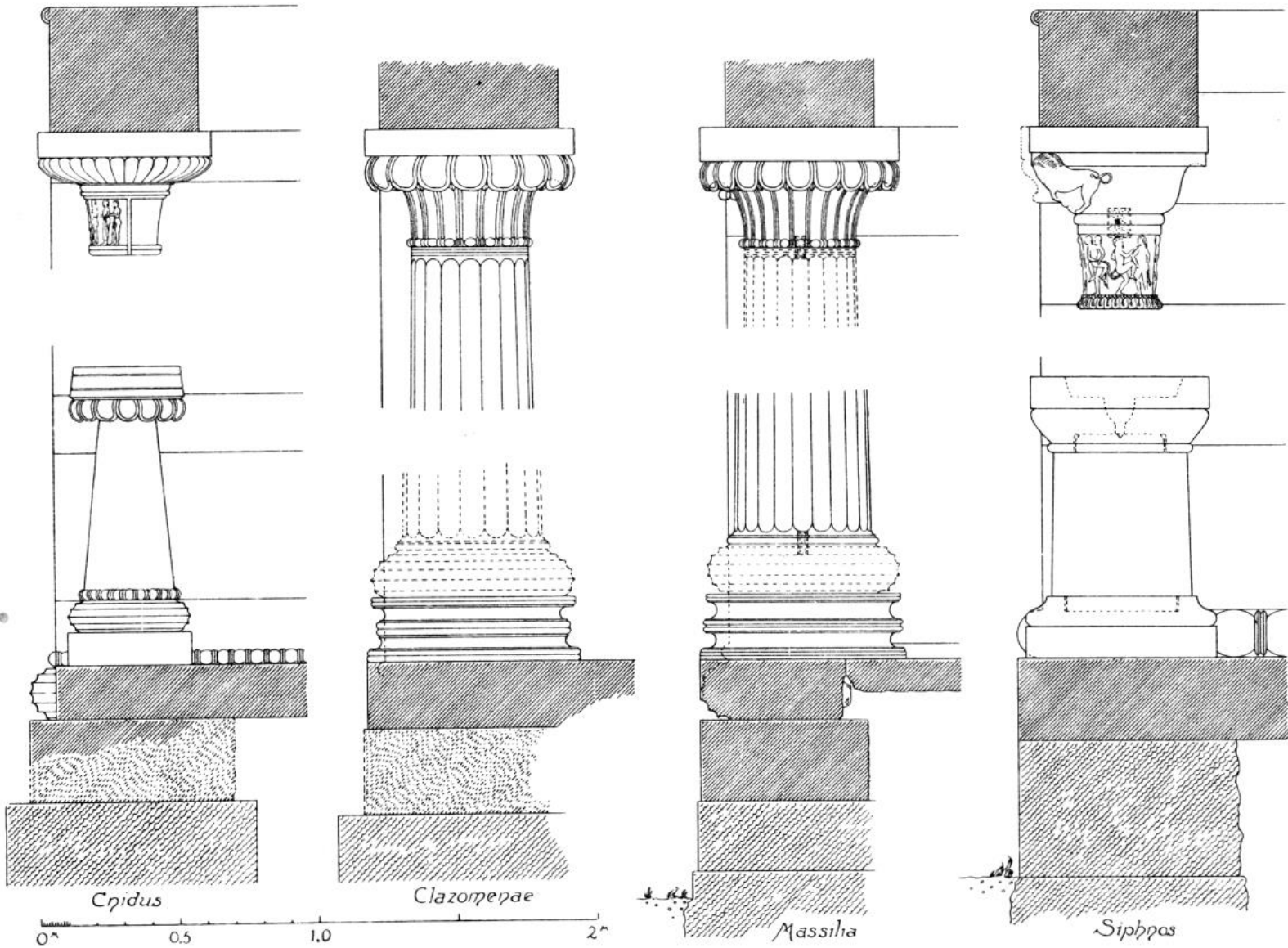
Fig. 8. - Les colonnes échappées au désastre de 1905.

Γ' ΝΑΟΣ ΑΘΗΝΑΣ











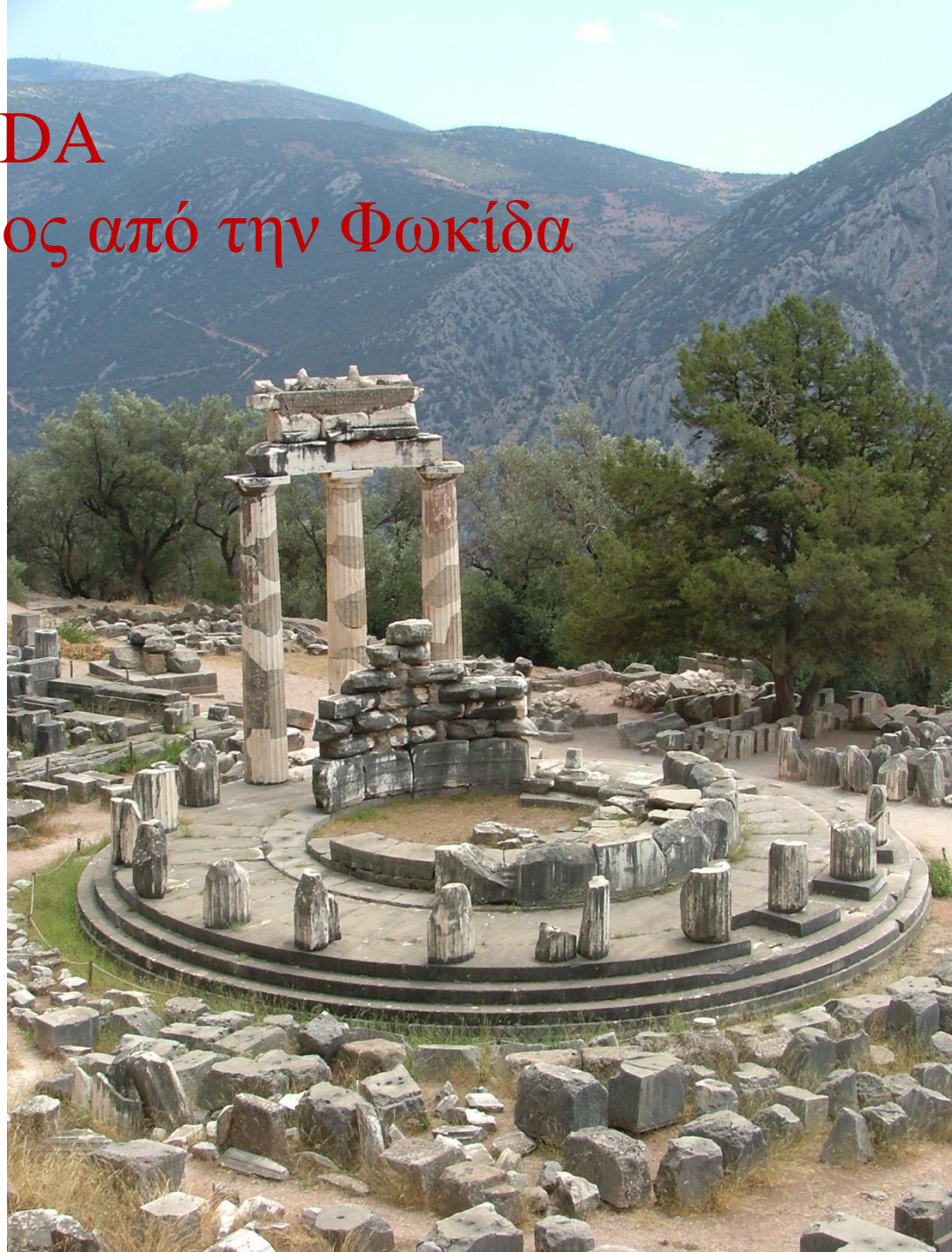


ΘΟΛΟΣ ΤΩΝ ΣΙΚΥΩΝΙΩΝ ΣΤΟΥΣ ΔΕΛΦΟΥΣ



ROTUNDA

Θεόδωρος από την Φωκίδα





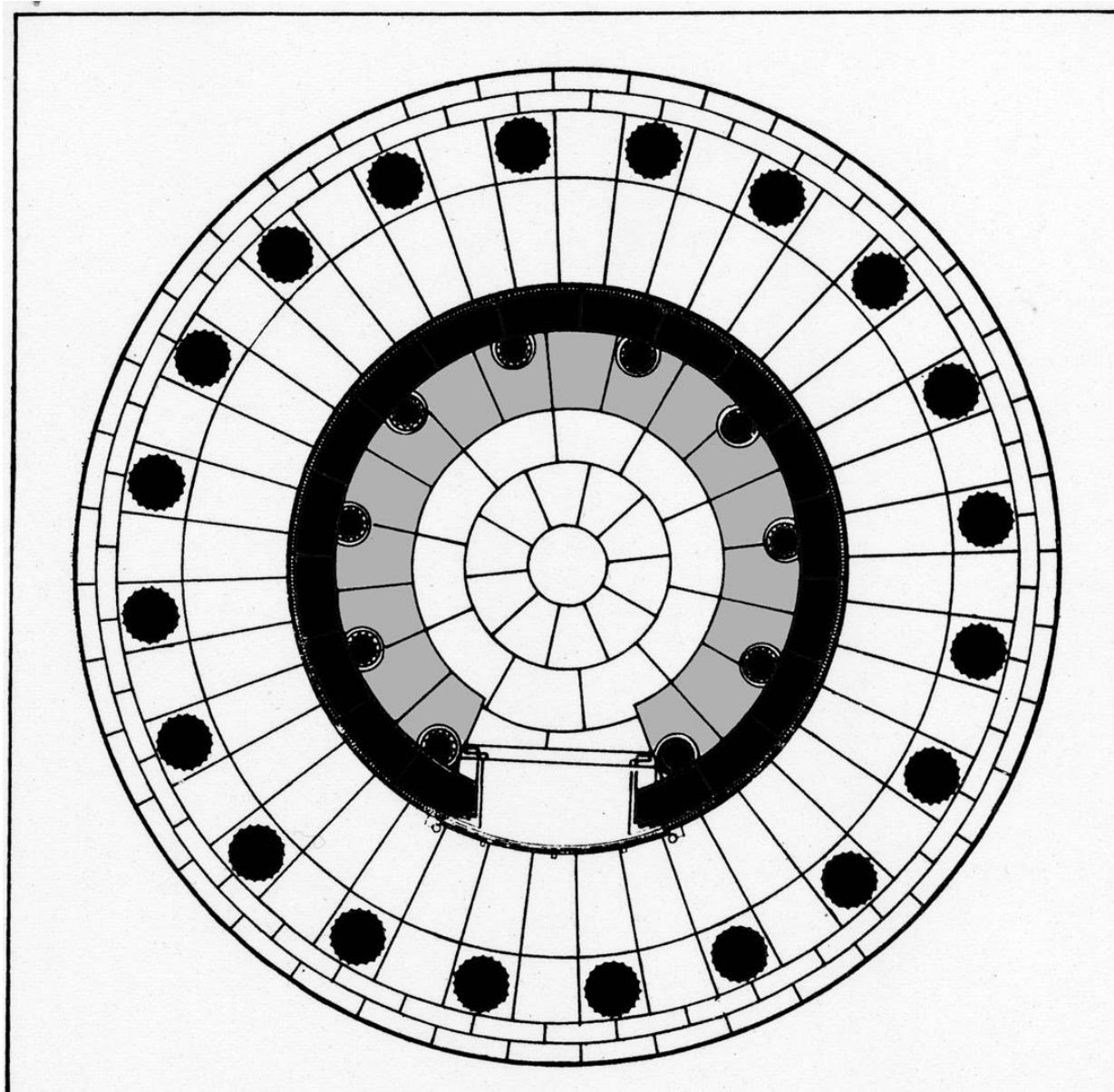


С. 310 ΔΕΛΦΟΙ. ΘΟΛΟΣ - ΜΑΡΜΑΡΙΑ - DELPHI, THOLOS - MARMARIA
DELPHES. THOLOS - MARMARIA - DELPHI, THOLOS - MARMARIA

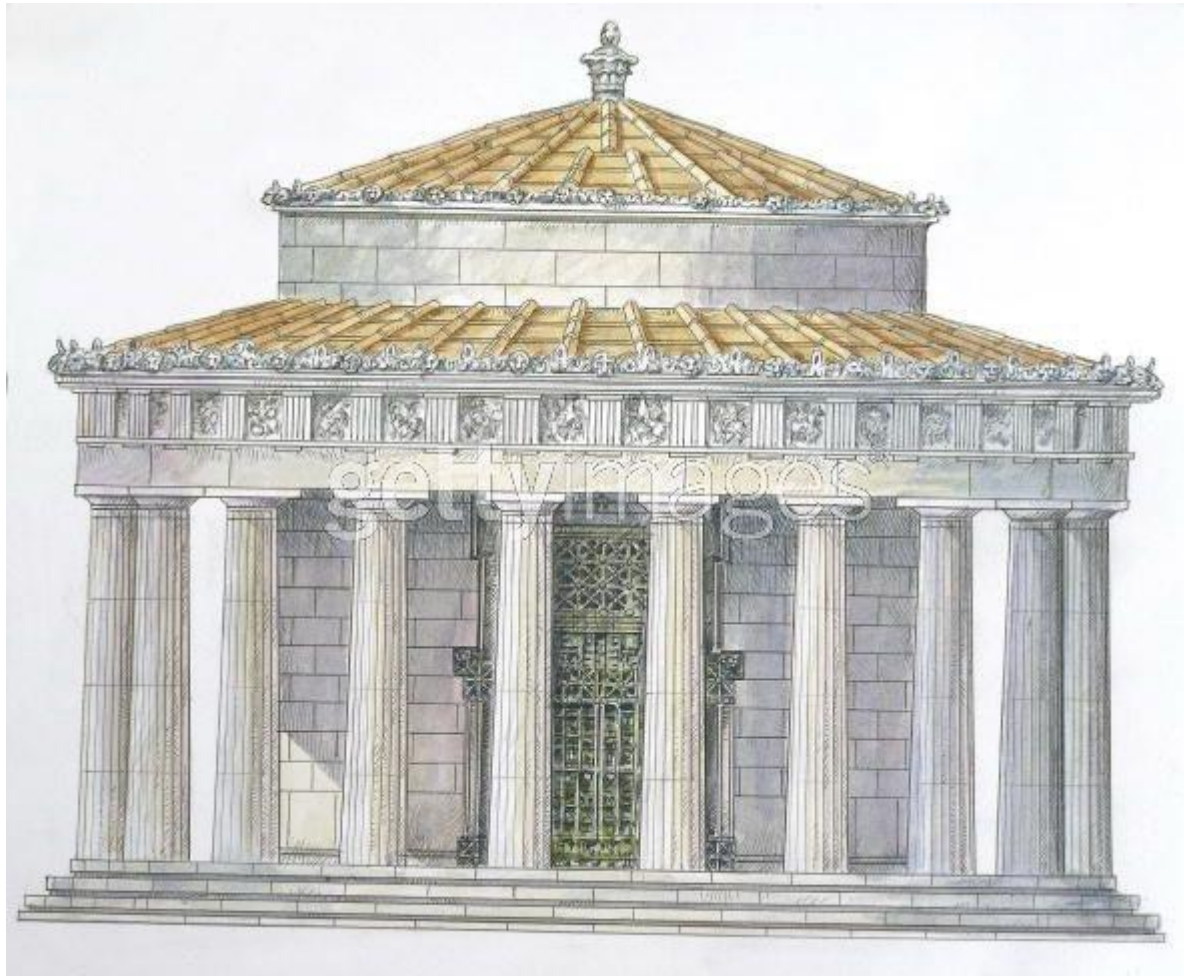
Ν. ΣΤΟΥΡΝΑΡΑΣ

LIFE

Ελευσινιακός λίθος...



ΚΙΓΚΛΙΔΕΣ





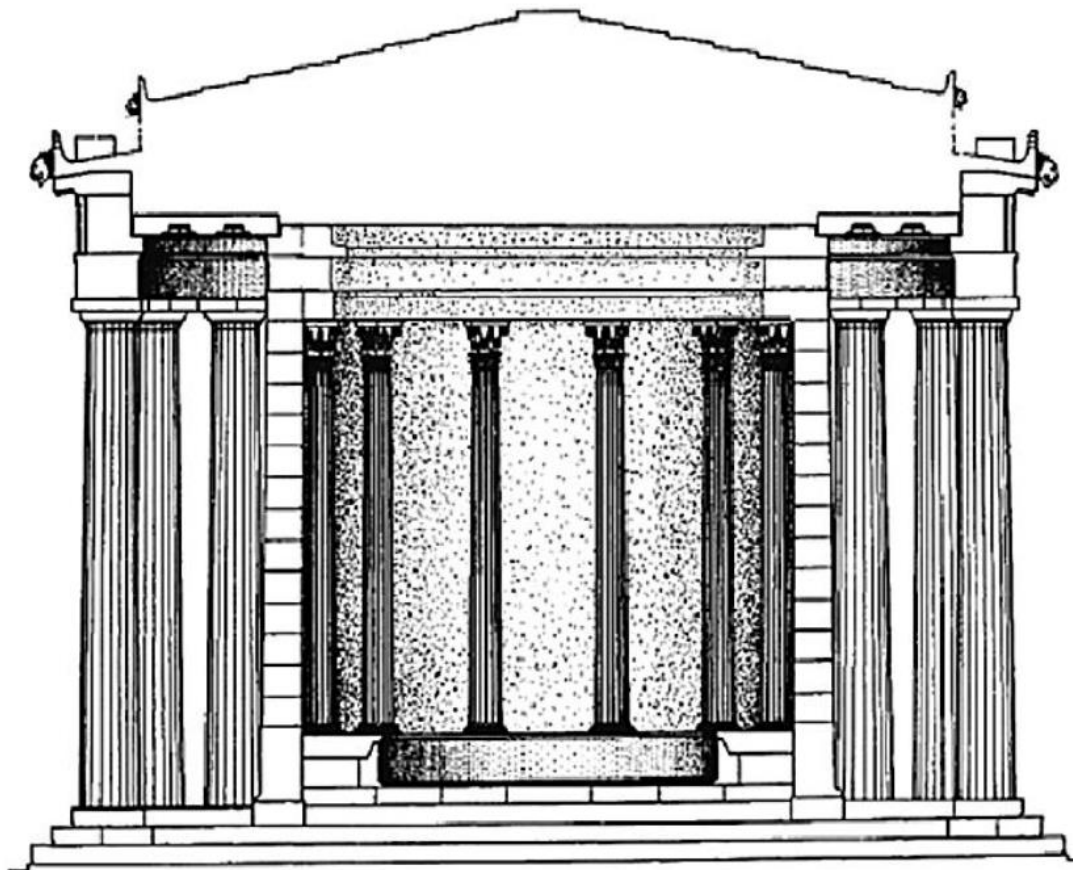
Επιδαυριανή σίμη. 80 ανάγλυφες μετόπες στο πτερό και στον σηκό
Αττικό ύφος
Εντύπωση «κρήνης»





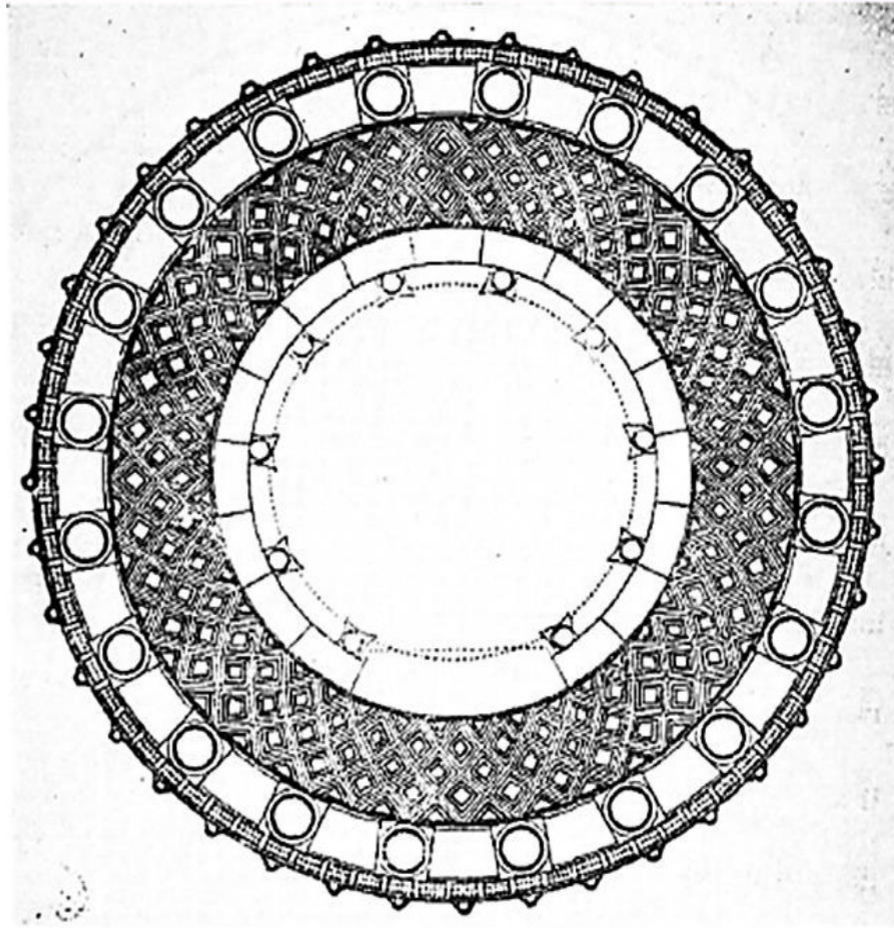


Εικόνα 7. Τα θραύσματα των 2 σιμών (Roux 1988, 299)



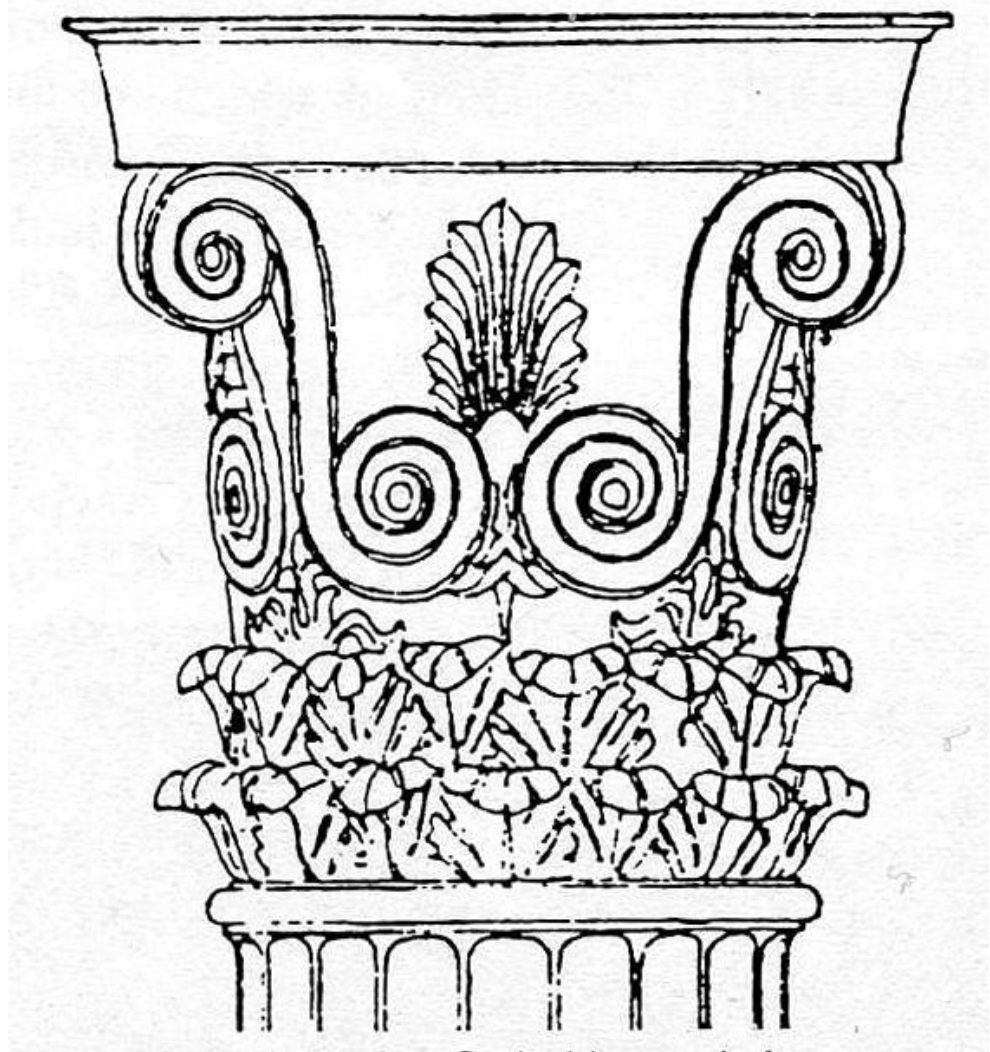
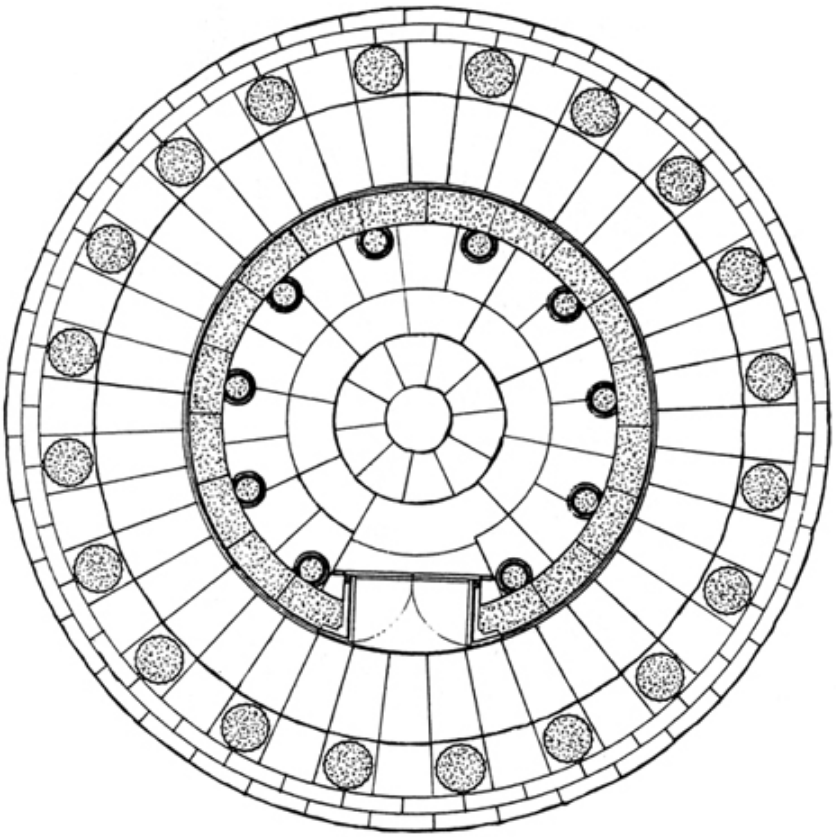
Εικόνα 3. Σχεδιαστική αναπαράσταση της Θόλου των Δελφών
(Seiler 1986, 61)

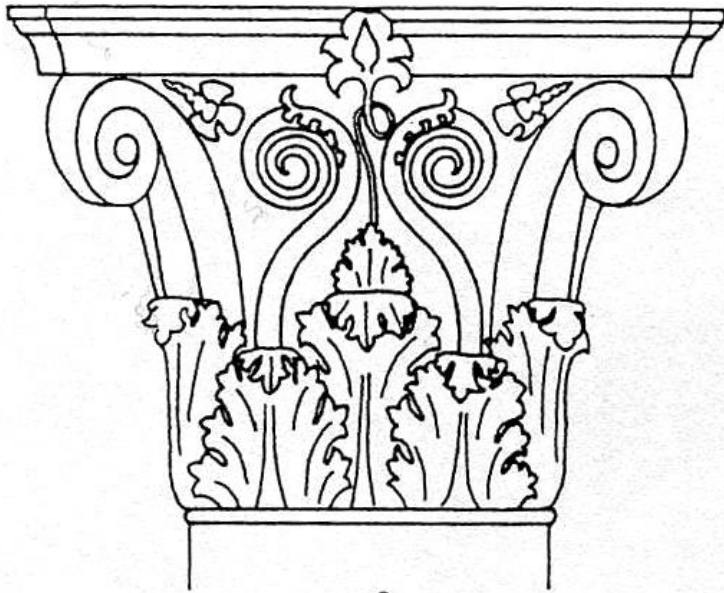
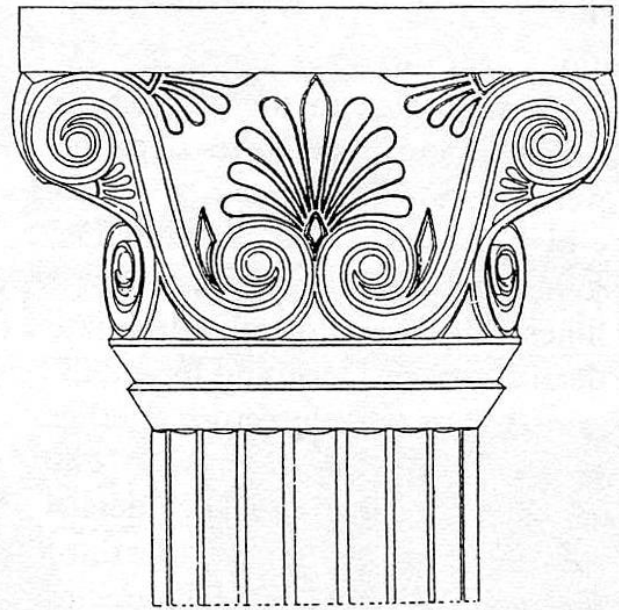
Τα πρώτα ρομβοειδή φανώματα



RENAME DELETE
Items to show

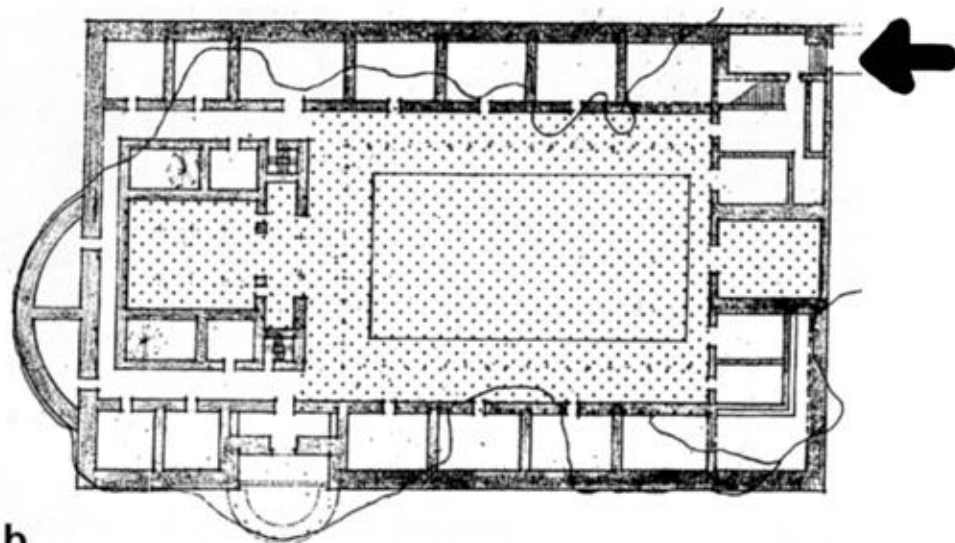
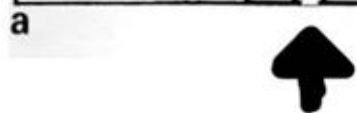
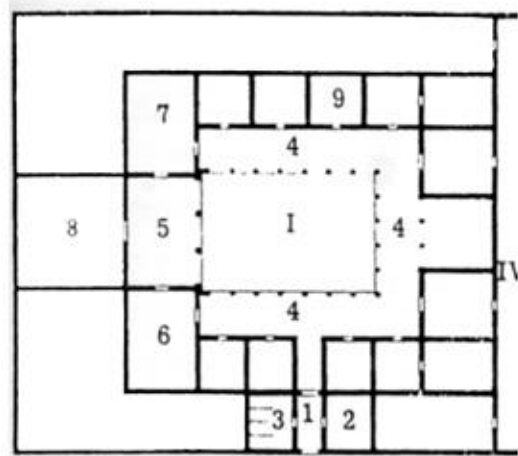




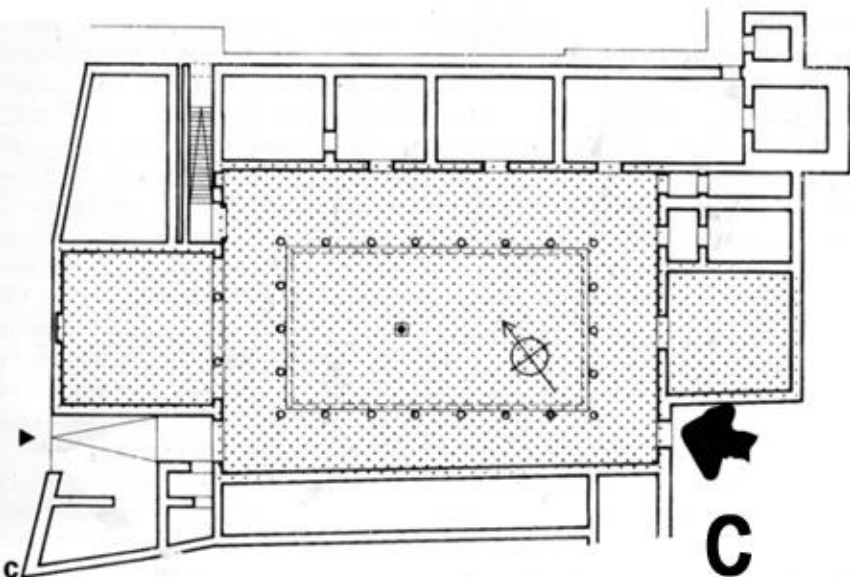


c

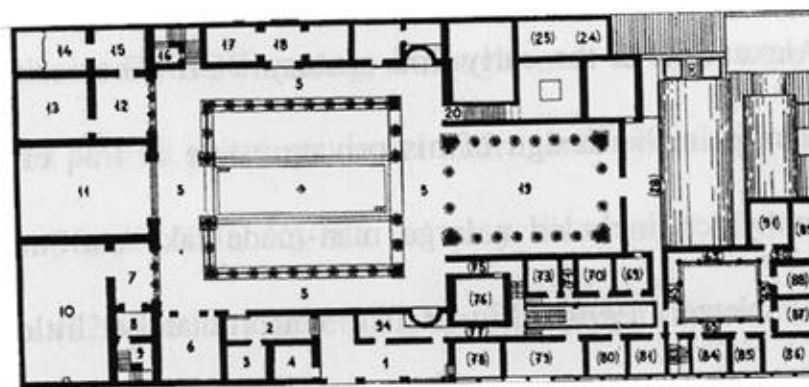




b



c



d